

Construction Standards Board
Bastrop City Hall City Council Chambers
1311 Chestnut Street
Bastrop, TX 78602
(512) 332-8840



Agenda – June 18, 2019 at 6:00 P.M.

City of Bastrop Construction Standards Board meetings are available to all persons regardless of disability. If you require special assistance, please contact the Board Secretary at (512) 332-8840 or write 1311 Chestnut Street, 78602, or by calling through a T.D.D. (Telecommunication Device for the Deaf) to Relay Texas at 1-800-735-2989 at least 48 hours in advance of the meeting.

As authorized by Section 551.071 of the Texas Government Code, this meeting may be convened into closed Executive Session for the purposes of seeking confidential legal advice from the City Attorney on any item on the agenda at any time during the meeting.

The City of Bastrop reserves the right to reconvene, recess, or realign the Regular Session or called Executive Session or order of business at any time prior to adjournment.

- 1. CALL TO ORDER**
- 2. CITIZEN COMMENTS**

At this time, three (3) minute comments will be taken from the audience on any topic. To address the Board, please submit a fully completed request card to the Board chairperson prior to the beginning of the meeting. In accordance with the Texas Open Meetings Act, if a citizen discusses any item not on the agenda, city Board cannot discuss issues raised or make any decision at this time. Instead, city Board are limited to making a statement of specific information or a recitation of existing policy in response to the inquiry. Issues may be referred to city staff for research and possible future action.

It is not the intention of the City of Bastrop to provide a public forum for the embarrassment or demeaning of any individual or group. Neither is it the intention of the Board to allow a member of the public to slur the performance, honesty, and/or integrity of the Board, as a body or any member or members of the Board, individually or collectively, nor any members of the city's staff. Accordingly, profane, insulting, or threatening language directed toward the Board and/or any person in the Board's presence will not be tolerated.

3. ITEMS FOR INDIVIDUAL CONSIDERATION

- 3A. Consider action to approve meeting minutes from the June 4, 2019 Construction Standards Board Meeting.
- 3B. Consider action to elect a Board Chair and Vice-Chair.
- 3C. Discuss the review and adoption of the 2018 International Building codes (I-Codes), including but not limited to the International Green Construction Code (IgCC), International Energy Conservation Code (IECC) and the International Existing Building Code (IEBC).

4. ADJOURNMENT

I, the undersigned authority, do hereby certify that this Notice of Meeting as posted in accordance with the regulations of the Texas Open Meetings Act on the bulletin board located at the entrance to the City of Bastrop City Hall, a place of convenient and readily accessible to the general public, as well as to the City's website, www.cityofbastrop.org and said Notice was posted on the following date and time: June 12, 2019 at 5:00 p.m. and remained posted for at least two hours after said meeting was convened.

Traci Chavez

Traci Chavez, Deputy City Secretary



STAFF REPORT

MEETING DATE: June 18, 2019

AGENDA ITEM: 3A

TITLE:

Consider action to approve meeting minutes from the June 4, 2019 Construction Standards Board Meeting.

STAFF REPRESENTATIVE:

Matt Jones, Director of Planning and Development

ATTACHMENTS:

- June 4, 2019 Meeting Minutes

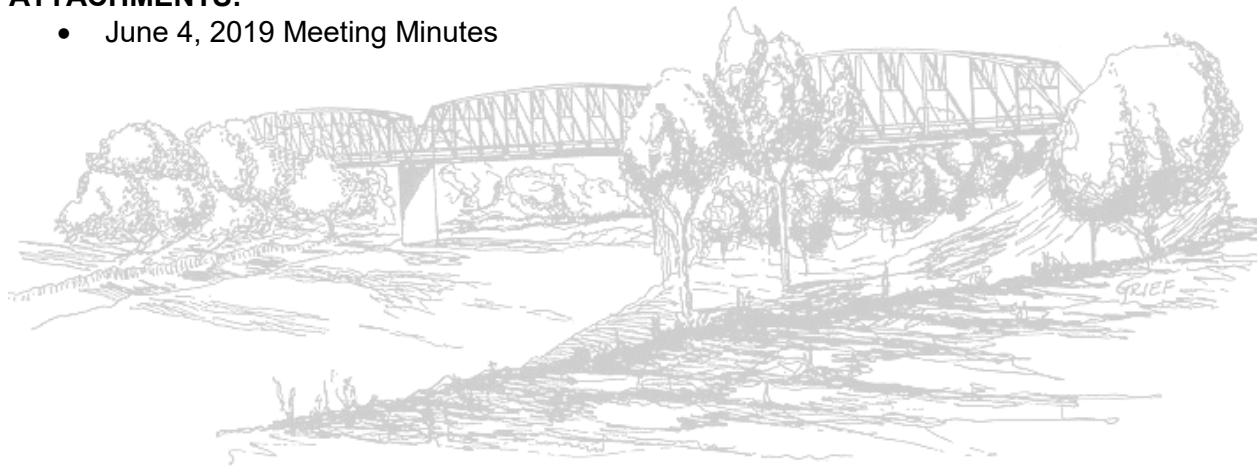

Construction Standards Board

Meeting Minutes

The City of Bastrop Construction Standards Board met Tuesday, June 4, 2019 at 6:00 p.m. in the Bastrop City Council Chambers, 1311 Chestnut Street, Bastrop, Texas.

1. CALL TO ORDER

Matt Jones, Director of Planning and Development called the meeting to order at 6:02 p.m. and noted that a quorum was present.

Chase McDonald	Present
Cliff Copeland	Present (arrived at 6:04pm)
David McKenzie	Present
Michael Osborn	Present
Joel Bauman	Absent

2. CITIZEN COMMENTS

There were no citizen comments.

3. ITEMS FOR INDIVIDUAL CONSIDERATION

3A. Consideration and approval of the June 4, 2019 meeting minutes.

Chase McDonald made a motion to recommend approval of the meeting minutes of October 13, 2016. Michael Osborn seconded the motion and the motion carried unanimously with the present three members.

Cliff Copeland arrived at 6:04 p.m.

3B. Discuss the review and adoption of the 2018 International Building codes (I-Codes), including but not limited to City Council's Policy Statement, significant dates, and proposed plan for review.

Matt Jones presented to the Board the City Council's Policy Statement and upcoming schedule and proposed plan for the adoption of the 2018 International Building Codes. No action was taken.

4. UPDATES

4A. Update on recent City Council actions regarding Planning Department items.

No updates were available.

Construction Standards Board Meeting Minutes

5. ADJOURNMENT

Michael Osborn made a motion to adjourn the meeting. The motion was seconded by David McKenzie and the motion carried unanimously with the meeting adjourned at 6:32 p.m.

Chair



STAFF REPORT

MEETING DATE: June 18, 2019

AGENDA ITEM: 3B

TITLE:

Consider action to elect a Board Chair and Vice-Chair.

STAFF REPRESENTATIVE:

Matt Jones, Director of Planning and Development

ATTACHMENTS:

- None





STAFF REPORT

MEETING DATE: June 18, 2019

AGENDA ITEM: 3C

TITLE:

Discuss the review and adoption of the 2018 International Building codes (I-Codes), including but not limited to the International Green Construction Code (IgCC), International Energy Conservation Code (IECC) and the International Existing Building Code (IEBC).

STAFF REPRESENTATIVE:

Matt Jones, Director of Planning and Development

BACKGROUND/HISTORY:

Building Bastrop launched on August 15, 2018 to create a new set of tools that will support the community in a responsible manner for generations to come. When looking at the Policy Statement adopted by City Council on February 26, 2019, a key component is that the codes be fiscally sustainable. The Building Bastrop Codes focus on the public realm (first 15' of a property), infrastructure, and life safety. The International Code Council (ICC) Building Codes (I-Codes) will regulate life safety. The I-Codes are standards used in the design, build, and compliance process to construct safe, sustainable, affordable, and resilient structures.

It is not uncommon for cities to update their codes every few years. Bastrop last updated these codes in 2012 when the 2009 I-Codes were adopted. There have been several updates to the I-Codes since 2009 and with the release of the 2018 I-Codes, we are now two (2) code updates behind and our building codes are over ten (10) years old.

The Construction Standards Board (CSB) has two main responsibilities. The first is to hear appeals of a decision made by the Building Official, and the second is to review and make recommendations to City Council regarding building codes. The CSB and Staff will review the 2018 I-Codes using the following proposed purpose statement as amended by City Council on March 26, 2019 for the basis of the code review:

“Review national best practices and establish locally amended life safety expectations that protect our public and ensure the asset meets or exceeds its useful life.”

The I-Code review process provides the CSB, Staff, and the community a chance to evaluate the codes for opportunities to make local amendments. Adopting localized amendments will ensure that the I-Codes as amended are fiscally sustainable, authentic Bastrop, and protect life safety.

Staff is committed to improve the development and permitting process. A part of that commitment will involve resolving conflicting language in different sections of the codes as part of this review. To decrease the chance of conflicting language in the future, the I-Codes will be referenced in the Building Bastrop Codes, but will be located in the Technical Manual. The Technical Manual will be a comprehensive manual serving as a single location for all technical criteria required to

develop or build in Bastrop. Having the codes located in one location will discourage the possibility of conflicting codes in different sections of the code.

Staff has established a set of review criteria that will serve as a guide when evaluating the codes. The evaluation criteria are listed below:

- Does it meet our purpose statement?
- Remember who the customer is.
- Does it make common sense?
- Can we legally enforce it?
- Does the code need to be inspected annually or another routine basis?

POLICY EXPLANATION:

Using Council's Purpose Statement for Building Bastrop as a guide, Staff developed a Purpose Statement for the I-Code update for use by the Construction Standards Board and Staff related to all code review. The proposed statement was reviewed and revised by City Council at their March 26th meeting.

FUNDING SOURCE:

N/A

RECOMMENDATION:

Discuss the review and adoption of the 2018 International Building codes (I-Codes), including but not limited to the International Green Construction Code (IgCC), International Energy Conservation Code (IECC) and the International Existing Building Code.

ATTACHMENTS:

- International Green Construction Code (IgCC)
- International Energy Conservation Code (IECC)
- International Existing Building Code (IEBC)



2 0 1 8

INTERNATIONAL CODES®

2018 I-CODE BONUS OFFER

Get a **free 45-day online subscription** to ICC's *premiumACCESS™* 2018 I-Codes Complete Collection. Test drive many powerful, time-saving tools available to you from *premiumACCESS*. To activate your bonus, visit www.iccsafe.org/codebonus.

IEBC®

A Member of the International Code Family®

INTERNATIONAL
EXISTING BUILDING CODE®



2018 International Existing Building Code®

First Printing: August 2017

ISBN: 978-1-60983-752-5 (soft-cover edition)
ISBN: 978-1-60983-751-8 (loose-leaf edition)

COPYRIGHT © 2017
by
INTERNATIONAL CODE COUNCIL, INC.

Date of First Publication: August 31, 2017

ALL RIGHTS RESERVED. This 2018 *International Existing Building Code*® is a copyrighted work owned by the International Code Council, Inc. Without advance written permission from the copyright owner, no part of this book may be reproduced, distributed or transmitted in any form or by any means, including, without limitation, electronic, optical or mechanical means (by way of example, and not limitation, photocopying or recording by or in an information storage retrieval system). For information on use rights and permissions, please contact: Publications, 4051 Flossmoor Road, Country Club Hills, IL 60478. Phone 1-888-ICC-SAFE (422-7233).

Trademarks: “International Code Council,” the “International Code Council” logo, “ICC,” the “ICC” logo, “International Existing Building Code,” “IEBC” and other names and trademarks appearing in this book are trademarks of the International Code Council, Inc., and/or its licensors (as applicable), and may not be used without permission.

PRINTED IN THE U.S.A.

PREFACE

Introduction

The *International Existing Building Code*® (IEBC®) establishes minimum requirements for existing buildings using prescriptive and performance-related provisions. It is founded on broad-based principles intended to encourage the use and reuse of existing buildings while requiring reasonable upgrades and improvements. This 2018 edition is fully compatible with all of the *International Codes*® (I-Codes®) published by the International Code Council® (ICC®), including the *International Building Code*®, *International Energy Conservation Code*®, *International Fire Code*®, *International Fuel Gas Code*®, *International Green Construction Code*®, *International Mechanical Code*®, *International Plumbing Code*®, *International Private Sewage Disposal Code*®, *International Property Maintenance Code*®, *International Residential Code*®, *International Swimming Pool and Spa Code*®, *International Wildland-Urban Interface Code*®, *International Zoning Code*® and *International Code Council Performance Code*®.

The I-Codes, including this *International Existing Building Code*, are used in a variety of ways in both the public and private sectors. Most industry professionals are familiar with the I-Codes as the basis of laws and regulations in communities across the U.S. and in other countries. However, the impact of the codes extends well beyond the regulatory arena, as they are used in a variety of non-regulatory settings, including:

- Voluntary compliance programs such as those promoting sustainability, energy efficiency and disaster resistance.
- The insurance industry, to estimate and manage risk, and as a tool in underwriting and rate decisions.
- Certification and credentialing of individuals involved in the fields of building design, construction and safety.
- Certification of building and construction-related products.
- U.S. federal agencies, to guide construction in an array of government-owned properties.
- Facilities management.
- “Best practices” benchmarks for designers and builders, including those who are engaged in projects in jurisdictions that do not have a formal regulatory system or a governmental enforcement mechanism.
- College, university and professional school textbooks and curricula.
- Reference works related to building design and construction.

In addition to the codes themselves, the code development process brings together building professionals on a regular basis. It provides an international forum for discussion and deliberation about building design, construction methods, safety, performance requirements, technological advances and innovative products.

Development

This 2018 edition presents the code as originally issued, with changes reflected in the 2006 through 2015 editions and further changes approved by the ICC Code Development Process through 2017. A new edition such as this is promulgated every 3 years.

This code is founded on principles intended to encourage the use and reuse of existing buildings that adequately protect public health, safety and welfare; provisions that do not unnecessarily increase construction costs; provisions that do not restrict the use of new materials, products or methods of construction; and provisions that do not give preferential treatment to particular types or classes of materials, products or methods of construction.

EFFECTIVE USE OF THE INTERNATIONAL EXISTING BUILDING CODE

The *International Existing Building Code* is a model code in the *International Code* family of codes intended to provide requirements for repair and alternative approaches for alterations and additions to existing buildings. A large number of existing buildings and structures do not comply with the current building code requirements for new construction. Although many of these buildings are potentially salvageable, rehabilitation is often cost-prohibitive because compliance with all the requirements for new construction could require extensive changes that go well beyond the value of the building or the original scope of the alteration. At the same time, it is necessary to regulate construction in existing buildings that undergo additions, alterations, extensive repairs or change of occupancy. Such activity represents an opportunity to ensure that new construction complies with the current building codes and that existing conditions are maintained, at a minimum, to their current level of compliance or are improved as required to meet basic safety levels. To accomplish this objective, and to make the alteration process easier, this code allows for options for controlled departure from full compliance with the *International Codes* dealing with new construction, while maintaining basic levels for fire prevention, structural and life safety features of the rehabilitated building.

This code provides three main options for a designer in dealing with alterations of existing buildings. These are laid out in Section 301 of this code:

OPTION 1: Work for alteration, change of occupancy or addition of all existing buildings shall be done in accordance with the Prescriptive Compliance Method given in Chapter 4. It should be noted that this method originates from the former Chapter 34 of the *International Building Code* (2012 and earlier editions).

OPTION 2: Work for alteration, change of occupancy or addition of all existing buildings shall be done in accordance with the Work Area Compliance Method given in Chapters 6 through 12.

OPTION 3: Work for alteration, change of occupancy or addition of all existing buildings shall be done in accordance with the Performance Compliance Method given in Chapter 13. It should be noted that this option was also provided in the former Chapter 34 of the *International Building Code* (2012 and earlier editions).

Under limited circumstances, a building alteration can be made to comply with the laws under which the building was originally built, as long as there has been no substantial structural damage and there will be limited structural alteration.

Note that all repairs must comply with Chapter 4 and relocated buildings are addressed by Chapter 14.

Arrangement and Format of the 2018 IEBC

Before applying the requirements of the IEBC, it is beneficial to understand its arrangement and format. The IEBC, like other codes published by ICC, is arranged and organized to follow logical steps that generally occur during a plan review or inspection. The IEBC is divided as follows:

Chapters	Subjects
1–2	Administrative Requirements and Definitions
3	Provisions for all Compliance Methods
4	Repairs
5	Prescriptive Compliance Method for Existing Buildings
6–12	Work Area Compliance Method for Existing Buildings
13	Performance Compliance Method for Existing Buildings
14	Relocated Buildings
15	Construction Safeguards

TABLE OF CONTENTS

CHAPTER 1 SCOPE AND ADMINISTRATION 1	402 Building Elements and Materials 21
PART 1—SCOPE AND APPLICATION 1	403 Fire Protection 21
Section	404 Means of Egress 21
101 General 1	405 Structural 21
102 Applicability 1	406 Electrical 22
PART 2—ADMINISTRATION	407 Mechanical 22
AND ENFORCEMENT 2	408 Plumbing 22
103 Department of Building Safety 2	CHAPTER 5 PRESCRIPTIVE
104 Duties and Powers of Code Official 2	COMPLIANCE METHOD 23
105 Permits 3	Section
106 Construction Documents 5	501 General 23
107 Temporary Structures and Uses 7	502 Additions 23
108 Fees 7	503 Alterations 24
109 Inspections 7	504 Fire Escapes 26
110 Certificate of Occupancy 8	505 Windows and Emergency Escape Openings 26
111 Service Utilities 8	506 Change of Occupancy 27
112 Board of Appeals 9	507 Historic Buildings 28
113 Violations 9	CHAPTER 6 CLASSIFICATION OF WORK 29
114 Stop Work Order 9	Section
115 Unsafe Buildings and Equipment 9	601 General 29
116 Emergency Measures 10	602 Alteration—Level 1 29
117 Demolition 10	603 Alteration—Level 2 29
CHAPTER 2 DEFINITIONS 11	604 Alteration—Level 3 29
Section	605 Change of Occupancy 29
201 General 11	606 Additions 29
202 General Definitions 11	607 Historic Buildings 29
CHAPTER 3 PROVISIONS FOR ALL	608 Relocated Buildings 29
COMPLIANCE METHODS 15	CHAPTER 7 ALTERATIONS—LEVEL 1 31
Section	Section
301 Administration 15	701 General 31
302 General Provisions 15	702 Building Elements and Materials 31
303 Structural Design Loads and Evaluation and Design Procedures 16	703 Fire Protection 32
304 In-Situ Load Tests 16	704 Means of Egress 32
305 Accessibility for Existing Buildings 16	705 Reroofing 32
CHAPTER 4 REPAIRS 21	706 Structural 33
Section	707 Energy Conservation 33
401 General 21	

CHAPTER 1

SCOPE AND ADMINISTRATION

User note:

About this chapter: Chapter 1 establishes the limits of applicability of the code and describes how the code is to be applied and enforced. Chapter 1 is in two parts: Part 1—Scope and Administration (Sections 101–102) and Part 2—Administration and Enforcement (Sections 103–117). Section 101 identifies which buildings and structures come under its purview and references other I-Codes[®] as applicable.

This code is intended to be adopted as a legally enforceable document, and it cannot be effective without adequate provisions for its administration and enforcement. The provisions of Chapter 1 establish the authority and duties of the code official appointed by the authority having jurisdiction and also establish the rights and privileges of the registered design professional, contractor and property owner.

PART 1—SCOPE AND APPLICATION

SECTION 101 GENERAL

[A] 101.1 Title. These regulations shall be known as the *Existing Building Code* of [NAME OF JURISDICTION], herein-after referred to as “this code.”

[A] 101.2 Scope. The provisions of this code shall apply to the *repair, alteration, change of occupancy, addition* to and relocation of *existing buildings*.

Exception: Detached one- and two-family *dwelling*s and multiple single-family *dwelling*s (*townhouses*) not more than three *stories above grade plane* in height with a separate *means of egress*, and their accessory structures not more than three *stories above grade plane* in height, shall comply with this code or the *International Residential Code*.

[A] 101.3 Intent. The intent of this code is to provide flexibility to permit the use of alternative approaches to achieve compliance with minimum requirements to safeguard the public health, safety and welfare insofar as they are affected by the *repair, alteration, change of occupancy, addition* and relocation of *existing buildings*.

[A] 101.4 Applicability. This code shall apply to the *repair, alteration, change of occupancy, addition* and relocation of *existing buildings*, regardless of occupancy, subject to the criteria of Sections 101.4.1 and 101.4.2.

[A] 101.4.1 Buildings not previously occupied. A building or portion of a building that has not been previously occupied or used for its intended purpose, in accordance with the laws in existence at the time of its completion, shall be permitted to comply with the provisions of the laws in existence at the time of its original permit unless such permit has expired. Subsequent permits shall comply with the *International Building Code* or *International Residential Code*, as applicable, for new construction.

[A] 101.4.2 Buildings previously occupied. The legal occupancy of any building existing on the date of adoption of this code shall be permitted to continue without change, except as is specifically covered in this code, the *International Fire Code*, or the *International Property Maintenance*

Code, or as is deemed necessary by the *code official* for the general safety and welfare of the occupants and the public.

[A] 101.5 Safeguards during construction. Construction work covered in this code, including any related demolition, shall comply with the requirements of Chapter 15.

[A] 101.6 Appendices. The *code official* is authorized to require retrofit of buildings, structures or individual structural members in accordance with the appendices of this code if such appendices have been individually adopted.

[A] 101.7 Correction of violations of other codes. *Repairs* or *alterations* mandated by any property, housing, or fire safety maintenance code or mandated by any licensing rule or ordinance adopted pursuant to law shall conform only to the requirements of that code, rule, or ordinance and shall not be required to conform to this code unless the code requiring such *repair* or *alteration* so provides.

SECTION 102 APPLICABILITY

[A] 102.1 General. Where there is a conflict between a general requirement and a specific requirement, the specific requirement shall be applicable. Where in any specific case different sections of this code specify different materials, methods of construction or other requirements, the most restrictive shall govern.

[A] 102.2 Other laws. The provisions of this code shall not be deemed to nullify any provisions of local, state, or federal law.

[A] 102.3 Application of references. References to chapter or section numbers or to provisions not specifically identified by number shall be construed to refer to such chapter, section, or provision of this code.

[A] 102.4 Referenced codes and standards. The codes and standards referenced in this code shall be considered part of the requirements of this code to the prescribed extent of each such reference and as further regulated in Sections 102.4.1 and 102.4.2.

Exception: Where enforcement of a code provision would violate the conditions of the listing of the equipment or appliance, the conditions of the listing shall govern.

[A] **102.4.1 Conflicts.** Where conflicts occur between provisions of this code and referenced codes and standards, the provisions of this code shall apply.

[A] **102.4.2 Conflicting provisions.** Where the extent of the reference to a referenced code or standard includes subject matter that is within the scope of this code, the provisions of this code, as applicable, shall take precedence over the provisions in the referenced code or standard.

[A] **102.5 Partial invalidity.** In the event that any part or provision of this code is held to be illegal or void, this shall not have the effect of making void or illegal any of the other parts or provisions.

PART 2—ADMINISTRATION AND ENFORCEMENT

SECTION 103

DEPARTMENT OF BUILDING SAFETY

[A] **103.1 Creation of enforcement agency.** The Department of Building Safety is hereby created, and the official in charge thereof shall be known as the *code official*.

[A] **103.2 Appointment.** The *code official* shall be appointed by the chief appointing authority of the jurisdiction.

[A] **103.3 Deputies.** In accordance with the prescribed procedures of this jurisdiction and with the concurrence of the appointing authority, the *code official* shall have the authority to appoint a deputy *code official*, the related technical officers, inspectors, plan examiners, and other employees. Such employees shall have powers as delegated by the *code official*.

SECTION 104

DUTIES AND POWERS OF CODE OFFICIAL

[A] **104.1 General.** The *code official* is hereby authorized and directed to enforce the provisions of this code. The *code official* shall have the authority to render interpretations of this code and to adopt policies and procedures in order to clarify the application of its provisions. Such interpretations, policies, and procedures shall be in compliance with the intent and purpose of this code. Such policies and procedures shall not have the effect of waiving requirements specifically provided for in this code.

[A] **104.2 Applications and permits.** The *code official* shall receive applications, review construction documents, and issue permits for the *repair, alteration, addition, demolition, change of occupancy,* and relocation of buildings; inspect the premises for which such permits have been issued; and enforce compliance with the provisions of this code.

[A] **104.2.1 Determination of substantially improved or substantially damaged existing buildings and structures in flood hazard areas.** For applications for reconstruction, rehabilitation, repair, *alteration, addition* or other improvement of *existing buildings* or structures located in *flood hazard areas*, the building official shall determine where the proposed work constitutes *substantial*

improvement or repair of *substantial damage*. Where the building official determines that the proposed work constitutes substantial improvement or repair of *substantial damage*, and where required by this code, the building official shall require the building to meet the requirements of Section 1612 of the *International Building Code*.

[A] **104.2.2 Preliminary meeting.** When requested by the permit applicant or the *code official*, the *code official* shall meet with the permit applicant prior to the application for a construction permit to discuss plans for the proposed work or *change of occupancy* in order to establish the specific applicability of the provisions of this code.

Exception: *Repairs and Level 1 alterations.*

[A] **104.2.2.1 Building evaluation.** The *code official* is authorized to require an *existing building* to be investigated and evaluated by a registered design professional based on the circumstances agreed on at the preliminary meeting. The design professional shall notify the *code official* if any potential noncompliance with the provisions of this code is identified.

[A] **104.3 Notices and orders.** The *code official* shall issue necessary notices or orders to ensure compliance with this code.

[A] **104.4 Inspections.** The *code official* shall make the required inspections, or the *code official* shall have the authority to accept reports of inspection by *approved agencies* or individuals. Reports of such inspections shall be in writing and be certified by a responsible officer of such approved agency or by the responsible individual. The *code official* is authorized to engage such expert opinion as deemed necessary to report on unusual technical issues that arise, subject to the approval of the appointing authority.

[A] **104.5 Identification.** The *code official* shall carry proper identification when inspecting structures or premises in the performance of duties under this code.

[A] **104.6 Right of entry.** Where it is necessary to make an inspection to enforce the provisions of this code, or where the *code official* has reasonable cause to believe that there exists in a structure or on a premises a condition that is contrary to or in violation of this code that makes the structure or premises *unsafe, dangerous,* or hazardous, the *code official* is authorized to enter the structure or premises at reasonable times to inspect or to perform the duties imposed by this code, provided that if such structure or premises be occupied that credentials be presented to the occupant and entry requested. If such structure or premises be unoccupied, the *code official* shall first make a reasonable effort to locate the owner, the owner's authorized agent or other person having charge or control of the structure or premises and request entry. If entry is refused, the *code official* shall have recourse to the remedies provided by law to secure entry.

[A] **104.7 Department records.** The *code official* shall keep official records of applications received, permits and certificates issued, fees collected, reports of inspections, and notices and orders issued. Such records shall be retained in the official records for the period required for retention of public records.

[A] **104.8 Liability.** The *code official*, member of the Board of Appeals, or employee charged with the enforcement of this code, while acting for the jurisdiction in good faith and without malice in the discharge of the duties required by this code or other pertinent law or ordinance, shall not thereby be rendered civilly or criminally liable personally and is hereby relieved from personal liability for any damage accruing to persons or property as a result of any act or by reason of an act or omission in the discharge of official duties.

[A] **104.8.1 Legal defense.** Any suit or criminal complaint instituted against an officer or employee because of an act performed by that officer or employee in the lawful discharge of duties and under the provisions of this code shall be defended by legal representatives of the jurisdiction until the final termination of the proceedings. The *code official* or any subordinate shall not be liable for cost in any action, suit, or proceeding that is instituted in pursuance of the provisions of this code.

[A] **104.9 Approved materials and equipment.** Materials, equipment, and devices *approved* by the *code official* shall be constructed and installed in accordance with such approval.

[A] **104.9.1 Used materials and equipment.** The use of used materials that meet the requirements of this code for new materials is permitted. Used equipment and devices shall be permitted to be reused subject to the approval of the *code official*.

[A] **104.10 Modifications.** Wherever there are practical difficulties involved in carrying out the provisions of this code, the *code official* shall have the authority to grant modifications for individual cases on application of the owner or owner's authorized representative, provided that the *code official* shall first find that special individual reason makes the strict letter of this code impractical, the modification is in compliance with the intent and purpose of this code and such modification does not lessen health, accessibility, life and fire safety, or structural requirements. The details of action granting modifications shall be recorded and entered in the files of the Department of Building Safety.

[A] **104.10.1 Flood hazard areas.** For *existing buildings* located in *flood hazard areas* for which *repairs, alterations* and *additions* constitute *substantial improvement*, the *code official* shall not grant modifications to provisions related to flood resistance unless a determination is made that:

1. The applicant has presented good and sufficient cause that the unique characteristics of the size, configuration or topography of the site render compliance with the flood-resistant construction provisions inappropriate.
2. Failure to grant the modification would result in exceptional hardship.
3. The granting of the modification will not result in increased flood heights, additional threats to public safety, extraordinary public expense nor create nuisances, cause fraud on or victimization of the public or conflict with existing laws or ordinances.

4. The modification is the minimum necessary to afford relief, considering the flood hazard.
5. A written notice will be provided to the applicant specifying, if applicable, the difference between the design flood elevation and the elevation to which the building is to be built, stating that the cost of flood insurance will be commensurate with the increased risk resulting from the reduced floor elevation and that construction below the design flood elevation increases risks to life and property.

[A] **104.11 Alternative materials, design and methods of construction, and equipment.** The provisions of this code are not intended to prevent the installation of any material or to prohibit any design or method of construction not specifically prescribed by this code, provided that any such alternative has been *approved*. An alternative material, design, or method of construction shall be *approved* where the *code official* finds that the proposed design is satisfactory and complies with the intent of the provisions of this code, and that the material, method, or work offered is, for the purpose intended, not less than the equivalent of that prescribed in this code in quality, strength, effectiveness, fire resistance, durability and safety. Where the alternative material, design or method of construction is not *approved*, the *code official* shall respond in writing, stating the reasons why the alternative was not *approved*.

[A] **104.11.1 Research reports.** Supporting data, where necessary to assist in the approval of materials or assemblies not specifically provided for in this code, shall consist of valid research reports from *approved* sources.

[A] **104.11.2 Tests.** Where there is insufficient evidence of compliance with the provisions of this code or evidence that a material or method does not conform to the requirements of this code, or in order to substantiate claims for alternative materials or methods, the *code official* shall have the authority to require tests as evidence of compliance to be made without expense to the jurisdiction. Test methods shall be as specified in this code or by other recognized test standards. In the absence of recognized and accepted test methods, the *code official* shall approve the testing procedures. Tests shall be performed by an *approved* agency. Reports of such tests shall be retained by the *code official* for the period required for retention.

SECTION 105 PERMITS

[A] **105.1 Required.** Any owner or owner's authorized agent who intends to repair, add to, alter, relocate, demolish, or change the occupancy of a building or to repair, install, add, alter, remove, convert, or replace any electrical, gas, mechanical, or plumbing system, the installation of which is regulated by this code, or to cause any such work to be performed, shall first make application to the *code official* and obtain the required permit.

[A] **105.1.1 Annual permit.** Instead of an individual permit for each *alteration* to an already *approved* electrical,

2. Describe the land on which the proposed work is to be done by legal description, street address, or similar description that will readily identify and definitely locate the proposed building or work.
3. Indicate the use and occupancy for which the proposed work is intended.
4. Be accompanied by construction documents and other information as required in Section 106.3.
5. State the valuation of the proposed work.
6. Be signed by the applicant or the applicant's authorized agent.
7. Give such other data and information as required by the *code official*.

[A] 105.3.1 Action on application. The *code official* shall examine or cause to be examined applications for permits and amendments thereto within a reasonable time after filing. If the application or the construction documents do not conform to the requirements of pertinent laws, the *code official* shall reject such application in writing, stating the reasons therefor. If the *code official* is satisfied that the proposed work conforms to the requirements of this code and laws and ordinances applicable thereto, the *code official* shall issue a permit therefor as soon as practicable.

[A] 105.3.2 Time limitation of application. An application for a permit for any proposed work shall be deemed to have been abandoned 180 days after the date of filing, unless such application has been pursued in good faith or a permit has been issued; except that the *code official* is authorized to grant one or more extensions of time for additional periods not exceeding 90 days each. The extension shall be requested in writing and justifiable cause demonstrated.

[A] 105.4 Validity of permit. The issuance or granting of a permit shall not be construed to be a permit for, or an approval of, any violation of any of the provisions of this code or of any other ordinance of the jurisdiction. Permits presuming to give authority to violate or cancel the provisions of this code or other ordinances of the jurisdiction shall not be valid. The issuance of a permit based on construction documents and other data shall not prevent the *code official* from requiring the correction of errors in the construction documents and other data. The *code official* is authorized to prevent occupancy or use of a structure where in violation of this code or of any other ordinances of this jurisdiction.

[A] 105.5 Expiration. Every permit issued shall become invalid unless the work on the site authorized by such permit is commenced within 180 days after its issuance, or if the work authorized on the site by such permit is suspended or abandoned for a period of 180 days after the time the work is commenced. The *code official* is authorized to grant, in writing, one or more extensions of time for periods not more than 180 days each. The extension shall be requested in writing and justifiable cause demonstrated.

[A] 105.6 Suspension or revocation. The *code official* is authorized to suspend or revoke a permit issued under the provisions of this code wherever the permit is issued in error or on the basis of incorrect, inaccurate, or incomplete infor-

mation or in violation of any ordinance or regulation or any of the provisions of this code.

[A] 105.7 Placement of permit. The building permit or copy shall be kept on the site of the work until the completion of the project.

SECTION 106 CONSTRUCTION DOCUMENTS

[A] 106.1 General. Submittal documents consisting of construction documents, special inspection and structural observation programs, investigation and evaluation reports, and other data shall be submitted in two or more sets with each application for a permit. The construction documents shall be prepared by a registered design professional where required by the statutes of the jurisdiction in which the project is to be constructed. Where special conditions exist, the *code official* is authorized to require additional construction documents to be prepared by a registered design professional.

Exception: The *code official* is authorized to waive the submission of construction documents and other data not required to be prepared by a registered design professional if it is found that the nature of the work applied for is such that reviewing of construction documents is not necessary to obtain compliance with this code.

[A] 106.2 Construction documents. Construction documents shall be in accordance with Sections 106.2.1 through 106.2.6.

[A] 106.2.1 Construction documents. Construction documents shall be dimensioned and drawn on suitable material. Electronic media documents are permitted to be submitted where *approved* by the *code official*. Construction documents shall be of sufficient clarity to indicate the location, nature and extent of the work proposed and show in detail that it will conform to the provisions of this code and relevant laws, ordinances, rules and regulations, as determined by the *code official*. The *work areas* shall be shown.

[A] 106.2.2 Fire protection system(s) shop drawings. Shop drawings for the fire protection system(s) shall be submitted to indicate compliance with this code and the construction documents and shall be *approved* prior to the start of system installation. Shop drawings shall contain information as required by the referenced installation standards in Chapter 9 of the *International Building Code*.

[A] 106.2.3 Means of egress. The construction documents for *Alterations—Level 2*, *Alterations—Level 3*, *additions* and *changes of occupancy* shall show in sufficient detail the location, construction, size and character of all portions of the means of egress in compliance with the provisions of this code. The construction documents shall designate the number of occupants to be accommodated in every *work area* of every floor and in all affected rooms and spaces.

[A] 106.2.4 Exterior wall envelope. Construction documents for work affecting the exterior wall envelope shall describe the exterior wall envelope in sufficient detail to determine compliance with this code. The construction

SECTION 107 TEMPORARY STRUCTURES AND USES

[A] 107.1 General. The *code official* is authorized to issue a permit for temporary uses. Such permits shall be limited as to time of service but shall not be permitted for more than 180 days. The *code official* is authorized to grant extensions for demonstrated cause.

[A] 107.2 Conformance. Temporary uses shall conform to the structural strength, fire safety, means of egress, accessibility, light, ventilation and sanitary requirements of this code as necessary to ensure the public health, safety and general welfare.

[A] 107.3 Temporary power. The *code official* is authorized to give permission to temporarily supply and use power in part of an electric installation before such installation has been fully completed and the final certificate of completion has been issued. The part covered by the temporary certificate shall comply with the requirements specified for temporary lighting, heat or power in NFPA 70.

[A] 107.4 Termination of approval. The *code official* is authorized to terminate such permit for a temporary use and to order the temporary use to be discontinued.

SECTION 108 FEES

[A] 108.1 Payment of fees. A permit shall not be valid until the fees prescribed by law have been paid. Nor shall an amendment to a permit be released until the additional fee, if any, has been paid.

[A] 108.2 Schedule of permit fees. On buildings, electrical, gas, mechanical, and plumbing systems or *alterations* requiring a permit, a fee for each permit shall be paid as required in accordance with the schedule as established by the applicable governing authority.

[A] 108.3 Building permit valuations. The applicant for a permit shall provide an estimated permit value at time of application. Permit valuations shall include total value of work including materials and labor for which the permit is being issued, such as electrical, gas, mechanical, plumbing equipment, and permanent systems. If, in the opinion of the *code official*, the valuation is underestimated on the application, the permit shall be denied unless the applicant can show detailed estimates to meet the approval of the *code official*. Final building permit valuation shall be set by the *code official*.

[A] 108.4 Work commencing before permit issuance. Any person who commences any work before obtaining the necessary permits shall be subject to an additional fee established by the *code official* that shall be in addition to the required permit fees.

[A] 108.5 Related fees. The payment of the fee for the construction, *alteration*, removal, or demolition of work done in connection to or concurrently with the work authorized by a building permit shall not relieve the applicant or holder of the permit from the payment of other fees that are prescribed by law.

[A] 108.6 Refunds. The *code official* is authorized to establish a refund policy.

SECTION 109 INSPECTIONS

[A] 109.1 General. Construction or work for which a permit is required shall be subject to inspection by the *code official*, and such construction or work shall remain visible and able to be accessed for inspection purposes until *approved*. Approval as a result of an inspection shall not be construed to be an approval of a violation of the provisions of this code or of other ordinances of the jurisdiction. Inspections presuming to give authority to violate or cancel the provisions of this code or of other ordinances of the jurisdiction shall not be valid. It shall be the duty of the permit applicant to cause the work to remain visible and able to be accessed for inspection purposes. Neither the *code official* nor the jurisdiction shall be liable for expense entailed in the removal or replacement of any material required to allow inspection.

[A] 109.2 Preliminary inspection. Before issuing a permit, the *code official* is authorized to examine or cause to be examined buildings and sites for which an application has been filed.

[A] 109.3 Required inspections. The *code official*, on notification, shall make the inspections set forth in Sections 109.3.1 through 109.3.10.

[A] 109.3.1 Footing or foundation inspection. Footing and foundation inspections shall be made after excavations for footings are complete and any required reinforcing steel is in place. For concrete foundations, any required forms shall be in place prior to inspection. Materials for the foundation shall be on the job, except where concrete is ready-mixed in accordance with ASTM C94, the concrete need not be on the job.

[A] 109.3.2 Concrete slab or under-floor inspection. Concrete slab and under-floor inspections shall be made after in-slab or under-floor reinforcing steel and building service equipment, conduit, piping accessories, and other ancillary equipment items are in place but before any concrete is placed or floor sheathing installed, including the subfloor.

[A] 109.3.3 Lowest floor elevation. For *additions* and *substantial improvements* to existing buildings in flood hazard areas, on placement of the lowest floor, including basement, and prior to further vertical construction, the elevation documentation required in the *International Building Code* shall be submitted to the *code official*.

[A] 109.3.4 Frame inspection. Framing inspections shall be made after the roof deck or sheathing, framing, fire blocking, and bracing are in place and pipes, chimneys, and vents to be concealed are complete and the rough electrical, plumbing, heating wires, pipes, and ducts are *approved*.

[A] 109.3.5 Lath or gypsum board inspection. Lath and gypsum board inspections shall be made after lathing and gypsum board, interior and exterior, is in place but before any plastering is applied or before gypsum board joints and fasteners are taped and finished.

Exception: Gypsum board that is not part of a fire-resistance-rated assembly or a shear assembly.

[A] 109.3.6 Weather-exposed balcony and walking surface waterproofing. Where the scope of work involves balconies or other elevated walking surfaces exposed to water from direct or blowing rain, snow or irrigation, and the structural framing is protected by an impervious moisture barrier, all elements of the impervious moisture barrier system shall not be concealed until inspected and *approved*.

Exception: Where special inspections are provided in accordance with Section 1705.1.1, Item 3, of the *International Building Code*.

[A] 109.3.7 Fire and smoke-resistant penetrations. Protection of joints and penetrations in fire-resistance-rated assemblies, smoke barriers and smoke partitions shall not be concealed from view until inspected and *approved*.

[A] 109.3.8 Other inspections. In addition to the inspections specified in Sections 109.2 through 109.3.7, the *code official* is authorized to make or require other inspections of any construction work to ascertain compliance with the provisions of this code and other laws that are enforced by the Department of Building Safety.

[A] 109.3.9 Special inspections. Special inspections shall be required in accordance with the *International Building Code*.

[A] 109.3.10 Final inspection. The final inspection shall be made after work required by the building permit is completed.

[A] 109.4 Inspection agencies. The *code official* is authorized to accept reports of *approved* inspection agencies, provided that such agencies satisfy the requirements as to qualifications and reliability.

[A] 109.5 Inspection requests. It shall be the duty of the holder of the building permit or their duly authorized agent to notify the *code official* when work is ready for inspection. It shall be the duty of the permit holder to provide access to and means for any inspections of such work that are required by this code.

[A] 109.6 Approval required. Work shall not be done beyond the point indicated in each successive inspection without first obtaining the approval of the *code official*. The *code official*, on notification, shall make the requested inspections and shall either indicate the portion of the construction that is satisfactory as completed or shall notify the permit holder or an agent of the permit holder wherein the same fails to comply with this code. Any portions that do not comply shall be corrected and such portion shall not be covered or concealed until authorized by the *code official*.

SECTION 110 CERTIFICATE OF OCCUPANCY

[A] 110.1 Change of occupancy. Altered areas of a building and relocated buildings shall not be used or occupied, and *change of occupancy* of a building or portion thereof shall not be made until the *code official* has issued a certificate of occupancy therefor as provided herein. Issuance of a certificate of occupancy shall not be construed as an approval of a violation of the provisions of this code or of other ordinances of the jurisdiction.

[A] 110.2 Certificate issued. After the *code official* inspects the building and does not find violations of the provisions of this code or other laws that are enforced by the Department of Building Safety, the *code official* shall issue a certificate of occupancy that contains the following:

1. The building permit number.
2. The address of the structure.
3. The name and address of the owner or the owner's authorized agent.
4. A description of that portion of the structure for which the certificate is issued.
5. A statement that the described portion of the structure has been inspected for compliance with the requirements of this code for the occupancy and division of occupancy and the use for which the proposed occupancy is classified.
6. The name of the *code official*.
7. The edition of the code under which the permit was issued.
8. The use and occupancy in accordance with the provisions of the *International Building Code*.
9. The type of construction as defined in the *International Building Code*.
10. The design occupant load and any impact the *alteration* has on the design occupant load of the area not within the scope of the work.
11. If fire protection systems are provided, whether the fire protection systems are required.
12. Any special stipulations and conditions of the building permit.

[A] 110.3 Temporary occupancy. The *code official* is authorized to issue a temporary certificate of occupancy before the completion of the entire work covered by the permit, provided that such portion or portions shall be occupied safely. The *code official* shall set a time period during which the temporary certificate of occupancy is valid.

[A] 110.4 Revocation. The *code official* is authorized to, in writing, suspend or revoke a certificate of occupancy or completion issued under the provisions of this code wherever the certificate is issued in error or on the basis of incorrect information supplied, or where it is determined that the building or structure or portion thereof is in violation of any ordinance or regulation or any of the provisions of this code.

SECTION 111 SERVICE UTILITIES

[A] 111.1 Connection of service utilities. A person shall not make connections from a utility, source of energy, fuel, or power to any building or system that is regulated by this code for which a permit is required, until *approved* by the *code official*.

[A] 111.2 Temporary connection. The *code official* shall have the authority to authorize the temporary connection of the building or system to the utility source of energy, fuel, or power.

[A] **111.3 Authority to disconnect service utilities.** The *code official* shall have the authority to authorize disconnection of utility service to the building, structure or system regulated by this code and the referenced codes and standards in case of emergency where necessary to eliminate an immediate hazard to life or property or where such utility connection has been made without the approval required by Section 111.1 or 111.2. The *code official* shall notify the serving utility and, wherever possible, the owner or the owner's authorized agent and the occupant of the building, structure or service system of the decision to disconnect prior to taking such action. If not notified prior to disconnecting, the owner or occupant of the building, structure or service system shall be notified in writing, as soon as practical thereafter.

SECTION 112 BOARD OF APPEALS

[A] **112.1 General.** In order to hear and decide appeals of orders, decisions, or determinations made by the *code official* relative to the application and interpretation of this code, there shall be and is hereby created a board of appeals. The board of appeals shall be appointed by the governing body and shall hold office at its pleasure. The board shall adopt rules of procedure for conducting its business.

[A] **112.2 Limitations on authority.** An application for appeal shall be based on a claim that the true intent of this code or the rules legally adopted thereunder have been incorrectly interpreted, the provisions of this code do not fully apply, or an equally good or better form of construction is proposed. The board shall not have authority to waive requirements of this code.

[A] **112.3 Qualifications.** The board of appeals shall consist of members who are qualified by experience and training to pass on matters pertaining to building construction and are not employees of the jurisdiction.

SECTION 113 VIOLATIONS

[A] **113.1 Unlawful acts.** It shall be unlawful for any person, firm, or corporation to *repair*, alter, extend, add, move, remove, demolish, or change the occupancy of any building or equipment regulated by this code or cause same to be done in conflict with or in violation of any of the provisions of this code.

[A] **113.2 Notice of violation.** The *code official* is authorized to serve a notice of violation or order on the person responsible for the *repair*, *alteration*, extension, *addition*, moving, removal, demolition, or change in the occupancy of a building in violation of the provisions of this code or in violation of a permit or certificate issued under the provisions of this code. Such order shall direct the discontinuance of the illegal action or condition and the abatement of the violation.

[A] **113.3 Prosecution of violation.** If the notice of violation is not complied with promptly, the *code official* is authorized to request the legal counsel of the jurisdiction to institute the appropriate proceeding at law or in equity to restrain, correct,

or abate such violation or to require the removal or termination of the unlawful occupancy of the building or structure in violation of the provisions of this code or of the order or direction made pursuant thereto.

[A] **113.4 Violation penalties.** Any person who violates a provision of this code or fails to comply with any of the requirements thereof or who *repairs* or alters or changes the occupancy of a building or structure in violation of the approved construction documents or directive of the *code official* or of a permit or certificate issued under the provisions of this code shall be subject to penalties as prescribed by law.

SECTION 114 STOP WORK ORDER

[A] **114.1 Authority.** Where the *code official* finds any work regulated by this code being performed in a manner contrary to the provisions of this code or in a *dangerous* or *unsafe* manner, the *code official* is authorized to issue a stop work order.

[A] **114.2 Issuance.** The stop work order shall be in writing and shall be given to the owner of the property involved, the owner's authorized agent or to the person doing the work. Upon issuance of a stop work order, the cited work shall immediately cease. The stop work order shall state the reason for the order and the conditions under which the cited work will be permitted to resume.

[A] **114.3 Unlawful continuance.** Any person who shall continue any work after having been served with a stop work order, except such work as that person is directed to perform to remove a violation or *unsafe* condition, shall be subject to penalties as prescribed by law.

SECTION 115 UNSAFE BUILDINGS AND EQUIPMENT

[A] **115.1 Conditions.** Buildings, structures or equipment that are or hereafter become *unsafe*, shall be taken down, removed or made safe as the *code official* deems necessary and as provided for in this code.

[A] **115.2 Record.** The *code official* shall cause a report to be filed on an *unsafe* condition. The report shall state the occupancy of the structure and the nature of the *unsafe* condition.

[A] **115.3 Notice.** If an *unsafe* condition is found, the *code official* shall serve on the owner, the owner's authorized agent or person in control of the structure a written notice that describes the condition deemed *unsafe* and specifies the required *repairs* or improvements to be made to abate the *unsafe* condition, or that requires the *unsafe* building to be demolished within a stipulated time. Such notice shall require the person thus notified to declare immediately to the *code official* acceptance or rejection of the terms of the order.

[A] **115.4 Method of service.** Such notice shall be deemed properly served if a copy thereof is delivered to the owner or the owner's authorized agent personally; sent by certified or registered mail addressed to the owner or the owner's authorized agent at the last known address with the return receipt

SCOPE AND ADMINISTRATION

requested; or delivered in any other manner as prescribed by local law. If the certified or registered letter is returned showing that the letter was not delivered, a copy thereof shall be posted in a conspicuous place in or about the structure affected by such notice. Service of such notice in the foregoing manner on the owner's authorized agent or on the person responsible for the structure shall constitute service of notice on the owner.

[A] 115.5 Restoration. The building or equipment determined to be *unsafe* by the *code official* is permitted to be restored to a safe condition. To the extent that *repairs, alterations, or additions* are made or a *change of occupancy* occurs during the restoration of the building, such *repairs, alterations, additions, or change of occupancy* shall comply with the requirements of this code.

SECTION 116 EMERGENCY MEASURES

[A] 116.1 Imminent danger. Where, in the opinion of the *code official*, there is imminent danger of failure or collapse of a building that endangers life, or where any building or part of a building has fallen and life is endangered by the occupation of the building, or where there is actual or potential danger to the building occupants or those in the proximity of any structure because of explosives, explosive fumes or vapors, or the presence of toxic fumes, gases, or materials, or operation of defective or dangerous equipment, the *code official* is hereby authorized and empowered to order and require the occupants to vacate the premises forthwith. The *code official* shall cause to be posted at each entrance to such structure a notice reading as follows: "This Structure Is Unsafe and Its Occupancy Has Been Prohibited by the Code Official." It shall be unlawful for any person to enter such structure except for the purpose of securing the structure, making the required *repairs*, removing the hazardous condition, or of demolishing the same.

[A] 116.2 Temporary safeguards. Notwithstanding other provisions of this code, whenever, in the opinion of the *code official*, there is imminent danger due to an unsafe condition, the *code official* shall order the necessary work to be done, including the boarding up of openings, to render such structure temporarily safe whether or not the legal procedure herein described has been instituted; and shall cause such other action to be taken as the *code official* deems necessary to meet such emergency.

[A] 116.3 Closing streets. Where necessary for public safety, the *code official* shall temporarily close structures and close or order the authority having jurisdiction to close sidewalks, streets, public ways, and places adjacent to *unsafe* structures, and prohibit the same from being utilized.

[A] 116.4 Emergency repairs. For the purposes of this section, the *code official* shall employ the necessary labor and materials to perform the required work as expeditiously as possible.

[A] 116.5 Costs of emergency repairs. Costs incurred in the performance of emergency work shall be paid by the jurisdiction. The legal counsel of the jurisdiction shall institute appropriate action against the owner of the premises or the

owner's authorized agent where the *unsafe* structure is or was located for the recovery of such costs.

[A] 116.6 Hearing. Any person ordered to take emergency measures shall comply with such order forthwith. Any affected person shall thereafter, on petition directed to the appeals board, be afforded a hearing as described in this code.

SECTION 117 DEMOLITION

[A] 117.1 General. The *code official* shall order the owner or owner's authorized agent of any premises on which is located any structure that in the *code official's* judgment is so old or dilapidated, or has become so out of *repair* as to be *dangerous, unsafe, insanitary* or otherwise unfit for human habitation of occupancy, and such that it is unreasonable to *repair* the structure, to demolish and remove such structure; or if such structure is capable of being made safe by *repairs, to repair* and make safe and sanitary or to demolish and remove to the owner's or the owner's authorized agent's option; or where there has been a cessation of normal construction of any structure for a period of more than two years, to demolish and remove such structure.

[A] 117.2 Notices and orders. Notices and orders shall comply with Section 113.

[A] 117.3 Failure to comply. If the owner or the owner's authorized agent of a premises fails to comply with a demolition order within the time prescribed, the *code official* shall cause the structure to be demolished and removed, either through an available public agency or by contract or arrangement with private persons, and the cost of such demolition and removal shall be charged against the real estate on which the structure is located and shall be a lien on such real estate.

[A] 117.4 Salvage materials. Where any structure has been ordered demolished and removed, the governing body or other designated officer under said contract or arrangement aforesaid shall have the right to sell the salvage and valuable materials at the highest price obtainable. The net proceeds of such sale, after deducting the expenses of such demolition and removal, shall be promptly remitted with a report of such sale or transaction, including the items of expense and the amounts deducted, for the person who is entitled thereto, subject to any order of a court. If such a surplus does not remain to be turned over, the report shall so state.

CHAPTER 2

DEFINITIONS

User note:

About this chapter: Codes, by their very nature, are technical documents. Every word, term and punctuation mark can add to or change the meaning of a technical requirement. It is necessary to maintain a consensus on the specific meaning of each term contained in the code. Chapter 2 performs this function by stating clearly what specific terms mean for the purpose of the code.

SECTION 201 GENERAL

201.1 Scope. Unless otherwise expressly stated, the following words and terms shall, for the purposes of this code, have the meanings shown in this chapter.

201.2 Interchangeability. Words used in the present tense include the future; words stated in the masculine gender include the feminine and neuter; the singular number includes the plural and the plural, the singular.

201.3 Terms defined in other codes. Where terms are not defined in this code and are defined in the other *International Codes*, such terms shall have the meanings ascribed to them in those codes.

201.4 Terms not defined. Where terms are not defined through the methods authorized by this chapter, such terms shall have ordinarily accepted meanings such as the context implies.

SECTION 202 GENERAL DEFINITIONS

[A] ADDITION. An extension or increase in floor area, number of stories, or height of a building or structure.

[A] ALTERATION. Any construction or renovation to an *existing structure* other than a *repair* or *addition*.

[A] APPROVED. Acceptable to the *code official*.

[A] BUILDING. Any structure utilized or intended for supporting or sheltering any occupancy.

[A] CHANGE OF OCCUPANCY. A change in the use of a building or a portion of a building that results in any of the following:

1. A change of occupancy classification.
2. A change from one group to another group within an occupancy classification.
3. Any change in use within a group for which there is a change in application of the requirements of this code.

[A] CODE OFFICIAL. The officer or other designated authority charged with the administration and enforcement of this code.

[BS] DANGEROUS. Any building, structure or portion thereof that meets any of the conditions described below shall be deemed dangerous:

1. The building or structure has collapsed, has partially collapsed, has moved off its foundation, or lacks the necessary support of the ground.
2. There exists a significant risk of collapse, detachment or dislodgement of any portion, member, appurtenance or ornamentation of the building or structure under service loads.

[A] DEFERRED SUBMITTAL. Those portions of the design that are not submitted at the time of the application and that are to be submitted to the *code official* within a specified period.

[BS] DISPROPORTIONATE EARTHQUAKE DAMAGE. A condition of earthquake-related damage where both of the following occur:

1. The 0.3-second spectral acceleration at the building site as estimated by the United States Geological Survey for the earthquake in question is less than 40 percent of the mapped acceleration parameter SS.
2. The vertical elements of the lateral force-resisting system have suffered damage such that the lateral load-carrying capacity of any story in any horizontal direction has been reduced by more than 10 percent from its predamage condition.

EQUIPMENT OR FIXTURE. Any plumbing, heating, electrical, ventilating, air conditioning, refrigerating, and fire protection equipment, and elevators, dumbwaiters, escalators, boilers, pressure vessels and other mechanical facilities or installations that are related to building services. Equipment or fixture shall not include manufacturing, production, or process equipment, but shall include connections from building service to process equipment.

[A] EXISTING BUILDING. A building erected prior to the date of adoption of the appropriate code, or one for which a legal building permit has been issued.

[A] EXISTING STRUCTURE. A structure erected prior to the date of adoption of the appropriate code, or one for which a legal building permit has been issued.

CHAPTER 3

PROVISIONS FOR ALL COMPLIANCE METHODS

User note:

About this chapter: Chapter 3 explains the three compliance options for alterations and additions available in the code. In addition, this chapter also lays out the methods to be used for seismic design and evaluation throughout this code. Finally, this chapter clarifies that provisions in other I-Codes® related to repairs, alterations, additions, relocation and changes of occupancy must also be addressed unless they conflict with this code. In that case, this code takes precedence.

SECTION 301 ADMINISTRATION

301.1 General. The *repair, alteration, change of occupancy, addition* or relocation of all *existing buildings* shall comply with Section 301.2, 301.3, or 301.4.

301.2 Repairs. *Repairs* shall comply with the requirements of Chapter 4.

301.3 Alteration, addition or change of occupancy. The *alteration, addition or change of occupancy* of all *existing buildings* shall comply with one of the methods listed in Section 301.3.1, 301.3.2 or 301.3.3 as selected by the applicant. Sections 301.3.1 through 301.3.3 shall not be applied in combination with each other.

Exception: Subject to the approval of the *code official*, *alterations* complying with the laws in existence at the time the building or the affected portion of the building was built shall be considered in compliance with the provisions of this code. New structural members added as part of the *alteration* shall comply with the *International Building Code*. This exception shall not apply to alterations that constitute substantial improvement in *flood hazard areas*, which shall comply with Section 503.2, 701.3 or 1301.3.3. This exception shall not apply to the structural provisions of Chapter 5 or to the structural provisions of Sections 706, 806 and 906.

301.3.1 Prescriptive compliance method. *Alterations, additions and changes of occupancy* complying with Chapter 5 of this code in buildings complying with the *International Fire Code* shall be considered in compliance with the provisions of this code.

301.3.2 Work area compliance method. *Alterations, additions and changes of occupancy* complying with the applicable requirements of Chapters 6 through 12 of this code shall be considered in compliance with the provisions of this code.

301.3.3 Performance compliance method. *Alterations, additions and changes of occupancy* complying with Chapter 13 of this code shall be considered in compliance with the provisions of this code.

301.4 Relocated buildings. Relocated buildings shall comply with the requirements of Chapter 14.

301.5 Compliance with accessibility. Accessibility requirements for *existing buildings* shall comply with the 2009 edition of ICC A117.1.

SECTION 302 GENERAL PROVISIONS

302.1 Applicability. The provisions of Section 302 apply to all *alterations, repairs, additions, relocations* of structures and *changes of occupancy* regardless of compliance method.

302.2 Dangerous conditions. The *code official* shall have the authority to require the elimination of conditions deemed *dangerous*.

302.3 Additional codes. *Alterations, repairs, additions and changes of occupancy* to, or relocation of, *existing buildings* and structures shall comply with the provisions for *alterations, repairs, additions and changes of occupancy* or relocation, respectively, in this code and the *International Energy Conservation Code, International Fire Code, International Fuel Gas Code, International Mechanical Code, International Plumbing Code, International Private Sewage Disposal Code, International Property Maintenance Code, International Residential Code* and NFPA 70. Where provisions of the other codes conflict with provisions of this code, the provisions of this code shall take precedence.

302.4 Existing materials. Materials already in use in a building in compliance with requirements or approvals in effect at the time of their erection or installation shall be permitted to remain in use unless determined by the building official to be unsafe.

302.5 New and replacement materials. Except as otherwise required or permitted by this code, materials permitted by the applicable code for new construction shall be used. Like materials shall be permitted for *repairs and alterations*, provided that unsafe conditions are not created. Hazardous materials shall not be used where the code for new construction would not permit their use in buildings of similar occupancy, purpose and location.

[BS] 302.5.1 New structural members and connections. New structural members and connections shall comply with the detailing provisions of the *International Building Code* for new buildings of similar structure, purpose and location.

Exception: Where alternative design criteria are specifically permitted.

302.6 Occupancy and use. Where determining the appropriate application of the referenced sections of this code, the occupancy and use of a building shall be determined in accordance with Chapter 3 of the *International Building Code*.

**SECTION 303
STRUCTURAL DESIGN LOADS AND
EVALUATION AND DESIGN PROCEDURES**

[BS] 303.1 Live loads. Where an *addition* or *alteration* does not result in increased design live load, existing gravity load-carrying structural elements shall be permitted to be evaluated and designed for live loads *approved* prior to the *addition* or *alteration*. If the *approved* live load is less than that required by Section 1607 of the *International Building Code*, the area designated for the nonconforming live load shall be posted with placards of *approved* design indicating the *approved* live load. Where the *addition* or *alteration* results in increased design live load, the live load required by Section 1607 of the *International Building Code* shall be used.

[BS] 303.2 Snow loads on adjacent buildings. Where an *alteration* or *addition* changes the potential snow drift effects on an adjacent building, the *code official* is authorized to enforce Section 7.12 of ASCE 7.

[BS] 303.3 Seismic evaluation and design procedures. Where required, seismic evaluation or design shall be based on the procedures and criteria in this section, regardless of which compliance method is used.

[BS] 303.3.1 Compliance with full seismic forces. Where compliance requires the use of full seismic forces, the criteria shall be in accordance with one of the following:

1. One-hundred percent of the values in the *International Building Code*. Where the existing seismic force-resisting system is a type that can be designated as “Ordinary,” values of R , Ω_0 and C_d used for analysis in accordance with Chapter 16 of the *International Building Code* shall be those specified for structural systems classified as “Ordinary” in accordance with Table 12.2-1 of ASCE 7, unless it can be demonstrated that the structural system will provide performance equivalent to that of a “Detailed,” “Intermediate” or “Special” system.
2. ASCE 41, using a Tier 3 procedure and the two-level performance objective in Table 303.3.1 for the applicable *risk category*.

[BS] 303.3.2 Compliance with reduced seismic forces. Where seismic evaluation and design is permitted to use reduced seismic forces, the criteria used shall be in accordance with one of the following:

1. The *International Building Code* using 75 percent of the prescribed forces. Values of R , Ω_0 and C_d used for analysis shall be as specified in Section 303.3.1 of this code.

2. Structures or portions of structures that comply with the requirements of the applicable chapter in Appendix A as specified in Items 2.1 through 2.4 and subject to the limitations of the respective Appendix A chapters shall be deemed to comply with this section.

- 2.1. The seismic evaluation and design of unreinforced masonry bearing wall buildings in *Risk Category I* or *II* are permitted to be based on the procedures specified in Appendix Chapter A1.
 - 2.2. Seismic evaluation and design of the wall anchorage system in reinforced concrete and reinforced masonry wall buildings with flexible diaphragms in *Risk Category I* or *II* are permitted to be based on the procedures specified in Chapter A2.
 - 2.3. Seismic evaluation and design of cripple walls and sill plate anchorage in residential buildings of light-frame wood construction in *Risk Category I* or *II* are permitted to be based on the procedures specified in Chapter A3.
 - 2.4. Seismic evaluation and design of soft, weak, or open-front wall conditions in multiple-unit residential buildings of wood construction in *Risk Category I* or *II* are permitted to be based on the procedures specified in Chapter A4.
3. ASCE 41, using the performance objective in Table 303.3.2 for the applicable *risk category*.

**SECTION 304
IN-SITU LOAD TESTS**

[BS] 304.1 General. Where used, in-situ load tests shall be conducted in accordance with Section 1708 of the *International Building Code*.

**SECTION 305
ACCESSIBILITY FOR EXISTING BUILDINGS**

305.1 Scope. The provisions of Sections 305.1 through 305.9 apply to maintenance, *change of occupancy*, *additions* and *alterations* to *existing buildings*, including those identified as *historic buildings*. **

**[BS] TABLE 303.3.1
PERFORMANCE OBJECTIVES FOR USE IN ASCE 41 FOR COMPLIANCE WITH
FULL SEISMIC FORCES**

RISK CATEGORY (Based on IBC Table 1604.5)	STRUCTURAL PERFORMANCE LEVEL FOR USE WITH BSE-1N EARTHQUAKE HAZARD LEVEL	STRUCTURAL PERFORMANCE LEVEL FOR USE WITH BSE-2N EARTHQUAKE HAZARD LEVEL
I	Life Safety (S-3)	Collapse Prevention (S-5)
II	Life Safety (S-3)	Collapse Prevention (S-5)
III	Damage Control (S-2)	Limited Safety (S-4)
IV	Immediate Occupancy (S-1)	Life Safety (S-3)

[BS] TABLE 303.3.2
PERFORMANCE OBJECTIVES FOR USE IN ASCE 41 FOR COMPLIANCE WITH REDUCED SEISMIC FORCES

RISK CATEGORY (Based on IBC Table 1604.5)	STRUCTURAL PERFORMANCE LEVEL FOR USE WITH BSE-1E EARTHQUAKE HAZARD LEVEL	STRUCTURAL PERFORMANCE LEVEL FOR USE WITH BSE-2E EARTHQUAKE HAZARD LEVEL
I	Life Safety (S-3). See Note a	Collapse Prevention (S-5)
II	Life Safety (S-3). See Note a	Collapse Prevention (S-5)
III	Damage Control (S-2). See Note a	Limited Safety (S-4). See Note b
IV	Immediate Occupancy (S-1)	Life Safety (S-3). See Note c

- a. For Risk Categories I, II and III, the Tier 1 and Tier 2 procedures need not be considered for the BSE-1E earthquake hazard level.
- b. For Risk Category III, the Tier 1 screening checklists shall be based on the Collapse Prevention, except that checklist statements using the Quick Check provisions shall be based on *MS*-factors that are the average of the values for Collapse Prevention and Life Safety.
- c. For Risk Category IV, the Tier 1 screening checklists shall be based on Collapse Prevention, except that checklist statements using the Quick Check provisions shall be based on *MS*-factors for Life Safety.

305.2 Maintenance of facilities. A *facility* that is constructed or altered to be *accessible* shall be maintained *accessible* during occupancy.

305.3 Extent of application. An *alteration* of an existing *facility* shall not impose a requirement for greater accessibility than that which would be required for new construction. *Alterations* shall not reduce or have the effect of reducing accessibility of a *facility* or portion of a *facility*.

305.4 Change of occupancy. *Existing buildings* that undergo a change of group or occupancy shall comply with this section.

Exception: Type B dwelling or sleeping units required by Section 1107 of the *International Building Code* are not required to be provided in *existing buildings* and facilities undergoing a *change of occupancy* in conjunction with *alterations* where the *work area* is 50 percent or less of the aggregate area of the building.

305.4.1 Partial change of occupancy. Where a portion of the building is changed to a new occupancy classification, any *alterations* shall comply with Sections 305.6, 305.7 and 305.8.

305.4.2 Complete change of occupancy. Where an entire building undergoes a *change of occupancy*, it shall comply with Section 305.4.1 and shall have all of the following accessible features:

1. Not fewer than one accessible building entrance.
2. Not fewer than one accessible route from an accessible building entrance to *primary function* areas.
3. Signage complying with Section 1111 of the *International Building Code*.
4. Accessible parking, where parking is being provided.
5. Not fewer than one accessible passenger loading zone, where loading zones are provided.
6. Not fewer than one accessible route connecting accessible parking and accessible passenger loading zones to an accessible entrance.

Where it is *technically infeasible* to comply with the new construction standards for any of these requirements for a change of group or occupancy, Items 1 through 6

shall conform to the requirements to the maximum extent technically feasible.

Exception: The accessible features listed in Items 1 through 6 are not required for an accessible route to Type B units.

305.5 Additions. Provisions for new construction shall apply to *additions*. An *addition* that affects the accessibility to, or contains an area of, a *primary function* shall comply with the requirements in Section 305.7.

305.6 Alterations. A *facility* that is altered shall comply with the applicable provisions in Chapter 11 of the *International Building Code*, unless *technically infeasible*. Where compliance with this section is *technically infeasible*, the *alteration* shall provide access to the maximum extent technically feasible.

Exceptions:

1. The altered element or space is not required to be on an accessible route, unless required by Section 305.7.
2. Accessible means of egress required by Chapter 10 of the *International Building Code* are not required to be provided in existing facilities.
3. The *alteration* to Type A individually owned dwelling units within a Group R-2 occupancy shall be permitted to meet the provision for a Type B dwelling unit.
4. Type B dwelling or sleeping units required by Section 1107 of the *International Building Code* are not required to be provided in *existing buildings* and facilities undergoing *alterations* where the *work area* is 50 percent or less of the aggregate area of the building.

305.7 Alterations affecting an area containing a primary function. Where an *alteration* affects the accessibility to, or contains an area of *primary function*, the route to the *primary function* area shall be *accessible*. The accessible route to the *primary function* area shall include toilet facilities and drinking fountains serving the area of *primary function*.

Exceptions:

1. The costs of providing the *accessible* route are not required to exceed 20 percent of the costs of the *alterations* affecting the area of *primary function*.

PROVISIONS FOR ALL COMPLIANCE METHODS

2. This provision does not apply to *alterations* limited solely to windows, hardware, operating controls, electrical outlets and signs.
3. This provision does not apply to *alterations* limited solely to mechanical systems, electrical systems, installation or *alteration* of fire protection systems and abatement of hazardous materials.
4. This provision does not apply to *alterations* undertaken for the primary purpose of increasing the accessibility of a *facility*.
5. This provision does not apply to altered areas limited to Type B dwelling and sleeping units.

305.8 Scoping for alterations. The provisions of Sections 305.8.1 through 305.8.15 shall apply to *alterations* to *existing buildings* and *facilities*.

305.8.1 Entrances. Where an *alteration* includes alterations to an entrance that is not accessible, and the *facility* has an *accessible* entrance, the altered entrance is not required to be *accessible* unless required by Section 305.7. Signs complying with Section 1111 of the *International Building Code* shall be provided.

305.8.2 Elevators. Altered elements of existing elevators shall comply with ASME A17.1 and ICC A117.1. Such elements shall also be altered in elevators programmed to respond to the same hall call control as the altered elevator.

305.8.3 Platform lifts. Platform (wheelchair) lifts complying with ICC A117.1 and installed in accordance with ASME A18.1 shall be permitted as a component of an accessible route.

305.8.4 Stairways and escalators in existing buildings. Where an escalator or stairway is added where none existed previously and major structural modifications are necessary for installation, an accessible route shall be provided between the levels served by the escalator or stairways in accordance with Section 1104.4 of the *International Building Code*.

305.8.5 Ramps. Where slopes steeper than allowed by Section 1012.2 of the *International Building Code* are necessitated by space limitations, the slope of ramps in or providing access to existing facilities shall comply with Table 305.8.5.

**TABLE 305.8.5
RAMPS**

SLOPE	MAXIMUM RISE
Steeper than 1:10 but not steeper than 1:8	3 inches
Steeper than 1:12 but not steeper than 1:10	6 inches

For SI: 1 inch = 25.4 mm.

305.8.6 Accessible dwelling or sleeping units. Where Group I-1, I-2, I-3, R-1, R-2 or R-4 dwelling or sleeping units are being altered or added, the requirements of Section 1107 of the *International Building Code* for Accessible units apply only to the quantity of spaces being altered or added.

305.8.7 Type A dwelling or sleeping units. Where more than 20 Group R-2 dwelling or sleeping units are being altered or added, the requirements of Section 1107 of the *International Building Code* for Type A units apply only to the quantity of the spaces being altered or added.

305.8.8 Type B dwelling or sleeping units. Where four or more Group I-1, I-2, R-1, R-2, R-3 or R-4 dwelling or sleeping units are being added, the requirements of Section 1107 of the *International Building Code* for Type B units apply only to the quantity of the spaces being added. Where Group I-1, I-2, R-1, R-2, R-3 or R-4 dwelling or sleeping units are being altered and where the *work area* is greater than 50 percent of the aggregate area of the building, the requirements of Section 1107 of the *International Building Code* for Type B units apply only to the quantity of the spaces being altered.

305.8.9 Jury boxes and witness stands. In *alterations*, accessible wheelchair spaces are not required to be located within the defined area of raised jury boxes or witness stands and shall be permitted to be located outside these spaces where the ramp or lift access restricts or projects into the required means of egress.

305.8.10 Toilet rooms. Where it is *technically infeasible* to alter existing toilet and bathing rooms to be *accessible*, an *accessible* family or assisted-use toilet or bathing room constructed in accordance with Section 1109.2.1 of the *International Building Code* is permitted. The family or assisted-use toilet or bathing room shall be located on the same floor and in the same area as the existing toilet or bathing rooms. At the inaccessible toilet and bathing rooms, directional signs indicating the location of the nearest family or assisted-use toilet room or bathing room shall be provided. These directional signs shall include the International Symbol of Accessibility and sign characters shall meet the visual character requirements in accordance with ICC A117.1.

305.8.11 Additional toilet and bathing facilities. In assembly and mercantile occupancies, where additional toilet fixtures are added, not fewer than one accessible family or assisted-use toilet room shall be provided where required by Section 1109.2.1 of the *International Building Code*. In recreational facilities, where additional bathing rooms are being added, not fewer than one family or assisted-use bathing room shall be provided where required by Section 1109.2.1 of the *International Building Code*.

305.8.12 Dressing, fitting and locker rooms. Where it is *technically infeasible* to provide accessible dressing, fitting or locker rooms at the same location as similar types of rooms, one accessible room on the same level shall be provided. Where separate-sex facilities are provided, accessible rooms for each sex shall be provided. Separate-sex facilities are not required where only unisex rooms are provided.

305.8.13 Fuel dispensers. Operable parts of replacement fuel dispensers shall be permitted to be 54 inches (1370 mm) maximum, measuring from the surface of the vehicular way where fuel dispensers are installed on existing curbs.

CHAPTER 4

REPAIRS

User note:

About this chapter: Chapter 4 provides requirements for repairs of existing buildings. The provisions define conditions under which repairs may be made using materials and methods like those of the original construction or the extent to which repairs must comply with requirements for new buildings.

SECTION 401 GENERAL

401.1 Scope. Repairs shall comply with the requirements of this chapter. Repairs to *historic buildings* need only comply with Chapter 12.

401.2 Compliance. The work shall not make the building less complying than it was before the *repair* was undertaken.

[BS] 401.3 Flood hazard areas. In flood hazard areas, repairs that constitute *substantial improvement* shall require that the building comply with Section 1612 of the *International Building Code*, or Section R322 of the *International Residential Code*, as applicable.

SECTION 402 BUILDING ELEMENTS AND MATERIALS

402.1 Glazing in hazardous locations. Replacement glazing in hazardous locations shall comply with the safety glazing requirements of the *International Building Code* or *International Residential Code* as applicable.

Exception: Glass block walls, louvered windows and jalousies repaired with like materials.

SECTION 403 FIRE PROTECTION

403.1 General. Repairs shall be done in a manner that maintains the level of fire protection provided.

SECTION 404 MEANS OF EGRESS

404.1 General. Repairs shall be done in a manner that maintains the level of protection provided for the means of egress.

SECTION 405 STRUCTURAL

[BS] 405.1 General. Structural repairs shall be in compliance with this section and Section 401.2.

[BS] 405.2 Repairs to damaged buildings. Repairs to damaged buildings shall comply with this section.

[BS] 405.2.1 Repairs for less than substantial structural damage. Unless otherwise required by this section,

for damage less than *substantial structural damage*, the damaged elements shall be permitted to be restored to their predamage condition.

[BS] 405.2.1.1 Snow damage. Structural components whose damage was caused by or related to snow load effects shall be repaired, replaced or altered to satisfy the requirements of Section 1608 of the *International Building Code*.

[BS] 405.2.2 Disproportionate earthquake damage. A building assigned to Seismic Design Category D, E or F that has sustained *disproportionate earthquake damage* shall be subject to the requirements for buildings with substantial structural damage to vertical elements of the lateral force-resisting system.

[BS] 405.2.3 Substantial structural damage to vertical elements of the lateral force-resisting system. A building that has sustained *substantial structural damage* to the vertical elements of its lateral force-resisting system shall be evaluated in accordance with Section 405.2.3.1, and either repaired in accordance with Section 405.2.3.2 or repaired and retrofitted in accordance with Section 405.2.3.3, depending on the results of the evaluation.

Exceptions:

1. Buildings assigned to Seismic Design Category A, B or C whose *substantial structural damage* was not caused by earthquake need not be evaluated or retrofitted for load combinations that include earthquake effects.
2. One- and two-family dwellings need not be evaluated or retrofitted for load combinations that include earthquake effects.

[BS] 405.2.3.1 Evaluation. The building shall be evaluated by a registered design professional, and the evaluation findings shall be submitted to the *code official*. The evaluation shall establish whether the damaged building, if repaired to its predamage state, would comply with the provisions of the *International Building Code* for load combinations that include wind or earthquake effects, except that the seismic forces shall be the reduced seismic forces.

[BS] 405.2.3.2 Extent of repair for compliant buildings. If the evaluation establishes that the building in its predamage condition complies with the provisions of Section 405.2.3.1, then the damaged elements shall be permitted to be restored to their predamage condition.

[BS] 405.2.3.3 Extent of repair for noncompliant buildings. If the evaluation does not establish that the building in its predamage condition complies with the provisions of Section 405.2.3.1, then the building shall be retrofitted to comply with the provisions of this section. The wind loads for the *repair* and *retrofit* shall be those required by the building code in effect at the time of original construction, unless the damage was caused by wind, in which case the wind loads shall be in accordance with the *International Building Code*. The seismic loads for this *retrofit* design shall be those required by the building code in effect at the time of original construction, but not less than the reduced seismic forces.

[BS] 405.2.4 Substantial structural damage to gravity load-carrying components. Gravity load-carrying components that have sustained *substantial structural damage* shall be rehabilitated to comply with the applicable provisions for dead and live loads in the *International Building Code*. Snow loads shall be considered if the *substantial structural damage* was caused by or related to snow load effects. Undamaged gravity load-carrying components that receive dead, live or snow loads from rehabilitated components shall also be rehabilitated if required to comply with the design loads of the *rehabilitation* design.

[BS] 405.2.4.1 Lateral force-resisting elements. Regardless of the level of damage to vertical elements of the lateral force-resisting system, if *substantial structural damage* to gravity load-carrying components was caused primarily by wind or seismic effects, then the building shall be evaluated in accordance with Section 405.2.3.1 and, if noncompliant, retrofitted in accordance with Section 405.2.3.3.

Exceptions:

1. Buildings assigned to Seismic Design Category A, B, or C whose substantial structural damage was not caused by earthquake need not be evaluated or retrofitted for load combinations that include earthquake effects.
2. One- and two-family dwellings need not be evaluated or retrofitted for load combinations that include earthquake effects.

[BS] 405.2.5 Flood hazard areas. In *flood hazard* areas, buildings that have sustained *substantial damage* shall be brought into compliance with Section 1612 of the *International Building Code*, or Section R322 of the *International Residential Code*, as applicable.

SECTION 406 ELECTRICAL

406.1 Material. Existing electrical wiring and equipment undergoing *repair* shall be allowed to be repaired or replaced with like material.

406.1.1 Receptacles. Replacement of electrical receptacles shall comply with the applicable requirements of Section 406.4(D) of NFPA 70.

406.1.2 Plug fuses. Plug fuses of the Edison-base type shall be used for replacements only where there is no evi-

dence of over fusing or tampering per applicable requirements of Section 240.51(B) of NFPA 70.

406.1.3 Nongrounding-type receptacles. For replacement of nongrounding-type receptacles with grounding-type receptacles and for branch circuits that do not have an equipment grounding conductor in the branch circuitry, the grounding conductor of a grounding-type receptacle outlet shall be permitted to be grounded to any accessible point on the grounding electrode system or to any accessible point on the grounding electrode conductor in accordance with Section 250.130(C) of NFPA 70.

406.1.4 Group I-2 receptacles. Receptacles in patient bed locations of Group I-2 that are not “hospital grade” shall be replaced with “hospital grade” receptacles, as required by NFPA 99 and Article 517 of NFPA 70.

406.1.5 Grounding of appliances. Frames of electric ranges, wall-mounted ovens, counter-mounted cooking units, clothes dryers and outlet or junction boxes that are part of the existing branch circuit for these appliances shall be permitted to be grounded to the grounded circuit conductor in accordance with Section 250.140 of NFPA 70.

SECTION 407 MECHANICAL

407.1 General. Existing mechanical systems undergoing *repair* shall not make the building less complying than it was before the damaged occurred.

407.2 Mechanical draft systems for manually fired appliances and fireplaces. A mechanical draft system shall be permitted to be used with manually fired appliances and fireplaces where such a system complies with all of the following requirements:

1. The mechanical draft device shall be listed and installed in accordance with the manufacturer’s installation instructions.
2. A device shall be installed that produces visible and audible warning upon failure of the mechanical draft device or loss of electrical power at any time that the mechanical draft device is turned on. This device shall be equipped with a battery backup if it receives power from the building wiring.
3. A smoke detector shall be installed in the room with the appliance or fireplace. This device shall be equipped with a battery backup if it receives power from the building wiring.

SECTION 408 PLUMBING

408.1 Materials. Plumbing materials and supplies shall not be used for *repairs* that are prohibited in the *International Plumbing Code*.

408.2 Water closet replacement. The maximum water consumption flow rates and quantities for all replaced water closets shall be 1.6 gallons (6 L) per flushing cycle.

Exception: Blowout-design water closets [3.5 gallons (13 L) per flushing cycle].

*

CHAPTER 5

PRESCRIPTIVE COMPLIANCE METHOD

User note:

About this chapter: Chapter 5 provides details for the prescriptive compliance method—one of the three main options of compliance available in this code for buildings and structures undergoing alteration, addition or change of occupancy.

SECTION 501 GENERAL

501.1 Scope. The provisions of this chapter shall control the *alteration, addition and change of occupancy* of existing buildings and structures, including *historic buildings* and structures as referenced in Section 301.3.2.

Exception: Existing bleachers, grandstands and folding and telescopic seating shall comply with ICC 300.

501.1.1 Compliance with other methods. *Alterations, additions and changes of occupancy to existing buildings* and structures shall comply with the provisions of this chapter or with one of the methods provided in Section 301.3.

501.2 Fire-resistance ratings. Where *approved* by the *code official*, in buildings where an automatic sprinkler system installed in accordance with Section 903.3.1.1 or 903.3.1.2 of the *International Building Code* has been added, and the building is now sprinklered throughout, the required fire-resistance ratings of building elements and materials shall be permitted to meet the requirements of the current building code. The building is required to meet the other applicable requirements of the *International Building Code*.

Plans, investigation and evaluation reports, and other data shall be submitted indicating which building elements and materials the applicant is requesting the *code official* to review and approve for determination of applying the current building code fire-resistance ratings. Any special construction features, including fire-resistance-rated assemblies and smoke-resistive assemblies, conditions of occupancy, means of egress conditions, fire code deficiencies, *approved* modifications or *approved* alternative materials, design and methods of construction, and equipment applying to the building that impact required fire-resistance ratings shall be identified in the evaluation reports submitted.

SECTION 502 ADDITIONS

502.1 General. *Additions* to any building or structure shall comply with the requirements of the *International Building Code* for new construction. *Alterations* to the *existing building* or structure shall be made to ensure that the *existing building* or structure together with the *addition* are not less complying with the provisions of the *International Building Code* than the *existing building* or structure was prior to the *addition*. An *existing building* together with its *additions*

shall comply with the height and area provisions of Chapter 5 of the *International Building Code*.

[BS] 502.2 Disproportionate earthquake damage. A building assigned to Seismic Design Category D, E or F that has sustained *disproportionate earthquake damage* shall be subject to the requirements for buildings with substantial structural damage to vertical elements of the lateral force-resisting system.

[BS] 502.3 Flood hazard areas. For buildings and structures in *flood hazard* areas established in Section 1612.3 of the *International Building Code*, or Section R322 of the *International Residential Code*, as applicable, any *addition* that constitutes *substantial improvement* of the *existing structure* shall comply with the flood design requirements for new construction, and all aspects of the *existing structure* shall be brought into compliance with the requirements for new construction for flood design.

For buildings and structures in *flood hazard areas* established in Section 1612.3 of the *International Building Code*, or Section R322 of the *International Residential Code*, as applicable, any *additions* that do not constitute *substantial improvement* of the *existing structure* are not required to comply with the flood design requirements for new construction.

[BS] 502.4 Existing structural elements carrying gravity load. Any existing gravity load-carrying structural element for which an *addition* and its related *alterations* cause an increase in design dead, live or snow load, including snow drift effects, of more than 5 percent shall be replaced or altered as needed to carry the gravity loads required by the *International Building Code* for new structures. Any existing gravity load-carrying structural element whose vertical load-carrying capacity is decreased as part of the *addition* and its related *alterations* shall be considered to be an altered element subject to the requirements of Section 503.3. Any existing element that will form part of the lateral load path for any part of the *addition* shall be considered to be an existing lateral load-carrying structural element subject to the requirements of Section 502.5.

Exception: Buildings of Group R occupancy with not more than five dwelling or sleeping units used solely for residential purposes where the *existing building* and the *addition* together comply with the conventional light-frame construction methods of the *International Building Code* or the provisions of the *International Residential Code*.

[BS] 502.5 Existing structural elements carrying lateral load. Where the *addition* is structurally independent of the *existing structure*, existing lateral load-carrying structural elements shall be permitted to remain unaltered. Where the *addition* is not structurally independent of the *existing structure*, the *existing structure* and its *addition* acting together as a single structure shall be shown to meet the requirements of Sections 1609 and 1613 of the *International Building Code* using full seismic forces.

Exceptions:

1. Any existing lateral load-carrying structural element whose demand-capacity ratio with the *addition* considered is not more than 10 percent greater than its demand-capacity ratio with the *addition* ignored shall be permitted to remain unaltered. For purposes of calculating demand-capacity ratios, the demand shall consider applicable load combinations with design lateral loads or forces in accordance with Sections 1609 and 1613 of the *International Building Code*. For purposes of this exception, comparisons of demand-capacity ratios and calculation of design lateral loads, forces and capacities shall account for the cumulative effects of *additions* and *alterations* since original construction.
2. Buildings of Group R occupancy with not more than five dwelling or sleeping units used solely for residential purposes where the *existing building* and the *addition* together comply with the conventional light-frame construction methods of the *International Building Code* or the provisions of the *International Residential Code*.

502.6 Smoke alarms in existing portions of a building. Where an *addition* is made to a building or structure of a Group R or I-1 occupancy, the *existing building* shall be provided with smoke alarms in accordance with Section 1103.8 of the *International Fire Code*.

502.7 Carbon monoxide alarms in existing portions of a building. Where an *addition* is made to a building or structure of Group I-1, I-2, I-4 or R occupancy, the *existing building* shall be provided with carbon monoxide alarms in accordance with Section 1103.9 of the *International Fire Code* or Section R315 of the *International Residential Code*, as applicable.

Exceptions:

1. Work involving the exterior surfaces of buildings, such as the replacement of roofing or siding, the addition or replacement of windows or doors, or the addition of porches or decks.
2. Installation, alteration or *repairs* of plumbing or mechanical systems, other than fuel-burning appliances.

502.8 Additions to Group E facilities. For *additions* to Group E occupancies, storm shelters shall be provided in accordance with Section 1106.1.

**SECTION 503
ALTERATIONS**

503.1 General. Except as provided by Section 302.4, 302.5 or this section, *alterations* to any building or structure shall comply with the requirements of the *International Building Code* for new construction. *Alterations* shall be such that the *existing building* or structure is not less complying with the provisions of the *International Building Code* than the *existing building* or structure was prior to the *alteration*.

Exceptions:

1. An existing stairway shall not be required to comply with the requirements of Section 1011 of the *International Building Code* where the existing space and construction does not allow a reduction in pitch or slope.
2. Handrails otherwise required to comply with Section 1011.11 of the *International Building Code* shall not be required to comply with the requirements of Section 1014.6 of the *International Building Code* regarding full extension of the handrails where such extensions would be hazardous because of plan configuration.
3. Where provided in below-grade transportation stations, existing and new escalators shall have a clear width of less than 32 inches (815 mm).

[BS] 503.2 Flood hazard areas. For buildings and structures in *flood hazard areas* established in Section 1612.3 of the *International Building Code*, or Section R322 of the *International Residential Code*, as applicable, any *alteration* that constitutes *substantial improvement* of the *existing structure* shall comply with the flood design requirements for new construction, and all aspects of the *existing structure* shall be brought into compliance with the requirements for new construction for flood design.

For buildings and structures in *flood hazard areas* established in Section 1612.3 of the *International Building Code*, or Section R322 of the *International Residential Code*, as applicable, any *alterations* that do not constitute *substantial improvement* of the *existing structure* are not required to comply with the flood design requirements for new construction.

[BS] 503.3 Existing structural elements carrying gravity load. Any existing gravity load-carrying structural element for which an *alteration* causes an increase in design dead, live or snow load, including snow drift effects, of more than 5 percent shall be replaced or altered as needed to carry the gravity loads required by the *International Building Code* for new structures. Any existing gravity load-carrying structural element whose gravity load-carrying capacity is decreased as part of the *alteration* shall be shown to have the capacity to resist the applicable design dead, live and snow loads including snow drift effects required by the *International Building Code* for new structures.

Exceptions:

1. Buildings of Group R occupancy with not more than five dwelling or sleeping units used solely for resi-

[BS] 503.13 Voluntary lateral force-resisting system alterations. Structural *alterations* that are intended exclusively to improve the lateral force-resisting system and are not required by other sections of this code shall not be required to meet the requirements of Section 1609 or Section 1613 of the *International Building Code*, provided that all of the following apply:

1. The capacity of existing structural systems to resist forces is not reduced.
2. New structural elements are detailed and connected to existing or new structural elements as required by the *International Building Code* for new construction.
3. New or relocated nonstructural elements are detailed and connected to existing or new structural elements as required by the *International Building Code* for new construction.
4. The *alterations* do not create a structural irregularity as defined in ASCE 7 or make an existing structural irregularity more severe.

503.14 Smoke alarms. Individual sleeping units and individual dwelling units in Group R and I-1 occupancies shall be provided with smoke alarms in accordance with Section 1103.8 of the *International Fire Code*.

503.15 Carbon monoxide alarms. Carbon monoxide alarms shall be provided to protect sleeping units and dwelling units in Group I-1, I-2, I-4 and R occupancies in accordance with Section 1103.9 of the *International Fire Code*.

Exceptions:

1. Work involving the exterior surfaces of buildings, such as the replacement of roofing or siding, the addition or replacement of windows or doors, or the addition of porches or decks.
2. Installation, alteration or *repairs* of plumbing or mechanical systems, other than fuel-burning appliances.

503.16 Refuge areas. Where *alterations* affect the configuration of an area utilized as a refuge area, the capacity of the refuge area shall not be reduced below that required in Sections 503.16.1 through 503.16.3.

503.16.1 Smoke compartments. In Group I-2 and I-3 occupancies, the required capacity of the refuge areas for smoke compartments in accordance with Sections 407.5.1 and 408.6.2 of the *International Building Code* shall be maintained.

503.16.2 Ambulatory care. In ambulatory care facilities required to be separated by Section 422.2 of the *International Building Code*, the required capacity of the refuge areas for smoke compartments in accordance with Section 422.3.2 of the *International Building Code* shall be maintained.

503.16.3 Horizontal exits. The required capacity of the refuge area for horizontal exits in accordance with Section 1026.4 of the *International Building Code* shall be maintained.

**SECTION 504
FIRE ESCAPES**

504.1 Where permitted. Fire escapes shall be permitted only as provided for in Sections 504.1.1 through 504.1.4.

504.1.1 New buildings. Fire escapes shall not constitute any part of the required means of egress in new buildings.

504.1.2 Existing fire escapes. Existing fire escapes shall continue to be accepted as a component in the means of egress in *existing buildings* only.

504.1.3 New fire escapes. New fire escapes for *existing buildings* shall be permitted only where exterior stairways cannot be utilized because of lot lines limiting stairway size or because of sidewalks, alleys or roads at grade level. New fire escapes shall not incorporate ladders or access by windows.

504.1.4 Limitations. Fire escapes shall comply with this section and shall not constitute more than 50 percent of the required number of exits nor more than 50 percent of the required exit capacity.

504.2 Location. Where located on the front of the building and where projecting beyond the building line, the lowest landing shall be not less than 7 feet (2134 mm) or more than 12 feet (3658 mm) above grade, and shall be equipped with a counterbalanced stairway to the street. In alleyways and thoroughfares less than 30 feet (9144 mm) wide, the clearance under the lowest landing shall be not less than 12 feet (3658 mm).

504.3 Construction. The fire escape shall be designed to support a live load of 100 pounds per square foot (4788 Pa) and shall be constructed of steel or other *approved noncombustible materials*. Fire escapes constructed of wood not less than nominal 2 inches (51 mm) thick are permitted on buildings of Type V construction. Walkways and railings located over or supported by combustible roofs in buildings of Type III and IV construction are permitted to be of wood not less than nominal 2 inches (51 mm) thick.

504.4 Dimensions. Stairways shall be not less than 22 inches (559 mm) wide with risers not more than, and treads not less than, 8 inches (203 mm) and landings at the foot of stairways not less than 40 inches (1016 mm) wide by 36 inches (914 mm) long, located not more than 8 inches (203 mm) below the door.

504.5 Opening protectives. Doors and windows within 10 feet (3048 mm) of fire escape stairways shall be protected with ³/₄-hour opening protectives.

Exception: Opening protection shall not be required in buildings equipped throughout with an *approved* automatic sprinkler system.

**SECTION 505
WINDOWS AND EMERGENCY ESCAPE OPENINGS**

505.1 Replacement glass. The installation or replacement of glass shall be as required for new installations.

505.2 Replacement window opening control devices. In Group R-2 or R-3 buildings containing dwelling units, and

one- and two-family dwellings and townhouses regulated by the *International Residential Code*, window opening control devices complying with ASTM F2090 shall be installed where an existing window is replaced and where all of the following apply to the replacement window:

1. The window is operable.
2. The window replacement includes replacement of the sash and the frame.
3. One of the following applies:
 - 3.1. In Group R-2 or R-3 buildings containing dwelling units, the top of the sill of the window opening is at a height less than 36 inches (915 mm) above the finished floor.
 - 3.2. In one- and two-family dwellings and townhouses regulated by the *International Residential Code*, the top of the sill of the window opening is at a height less than 24 inches (610 mm) above the finished floor.
4. The window will permit openings that will allow passage of a 4-inch-diameter (102 mm) sphere when the window is in its largest opened position.
5. The vertical distance from the top of the sill of the window opening to the finished grade or other surface below, on the exterior of the building, is greater than 72 inches (1829 mm).

The window opening control device, after operation to release the control device allowing the window to fully open, shall not reduce the minimum net clear opening area of the window unit to less than the area required by Section 1030.2 of the *International Building Code*.

Exceptions:

1. Operable windows where the top of the sill of the window opening is located more than 75 feet (22 860 mm) above the finished grade or other surface below, on the exterior of the room, space or building, and that are provided with window fall prevention devices that comply with ASTM F2006.
2. Operable windows with openings that are provided with window fall prevention devices that comply with ASTM F2090.

505.3 Replacement window emergency escape and rescue openings. Where windows are required to provide *emergency escape and rescue openings* in Group R-2 and R-3 occupancies and one- and two-family dwellings and townhouses regulated by the *International Residential Code*, replacement windows shall be exempt from the requirements of Sections 1030.2, 1030.3 and 1030.4 of the *International Building Code* and Sections R310.2.1, R310.2.2 and R310.2.3 of the *International Residential Code*, provided that the replacement window meets the following conditions:

1. The replacement window is the manufacturer’s largest standard size window that will fit within the existing frame or existing rough opening. The replacement window shall be permitted to be of the same operating style as the existing window or a style that provides for an equal or greater window opening area than the existing window.

2. The replacement of the window is not part of a *change of occupancy*.

Window opening control devices complying with ASTM F2090 shall be permitted for use on windows required to provide emergency escape and rescue openings.

505.4 Emergency escape and rescue openings. Emergency escape and rescue openings shall be operational from the inside of the room without the use of keys or tools. Bars, grilles, grates or similar devices are permitted to be placed over emergency escape and rescue openings provided that the minimum net clear opening size complies with the code that was in effect at the time of construction and such devices shall be releasable or removable from the inside without the use of a key, tool or force greater than that which is required for normal operation of the escape and rescue opening. Where such bars, grilles, grates or similar devices are installed, they shall not reduce the net clear opening of the emergency escape and rescue openings. Smoke alarms shall be installed in accordance with Section 907.2.10 of the *International Building Code* regardless of the valuation of the alteration.

**SECTION 506
CHANGE OF OCCUPANCY**

506.1 Compliance. A *change of occupancy* shall not be made in any building unless that building is made to comply with the requirements of the *International Building Code* for the use or occupancy. Changes of occupancy in a building or portion thereof shall be such that the *existing building* is not less complying with the provisions of this code than the *existing building* or structure was prior to the change. Subject to the approval of the building official, changes of occupancy shall be permitted without complying with all of the requirements of this code for the new occupancy, provided that the new occupancy is less hazardous, based on life and fire risk, than the existing occupancy.

Exception: The building need not be made to comply with Chapter 16 of the *International Building Code* unless required by Section 506.4.

506.1.1 Change in the character of use. A change of occupancy with no *change of occupancy* classification shall not be made to any structure that will subject the structure to any special provisions of the applicable *International Codes*, without approval of the *code official*. Compliance shall be only as necessary to meet the specific provisions and is not intended to require the entire building be brought into compliance.

506.2 Certificate of occupancy. A certificate of occupancy shall be issued where it has been determined that the requirements for the new occupancy classification have been met.

506.3 Stairways. An existing stairway shall not be required to comply with the requirements of Section 1011 of the *International Building Code* where the existing space and construction does not allow a reduction in pitch or slope.

506.4 Structural. Any building undergoing a *change of occupancy* shall satisfy the requirements of this section.

506.4.1 Live loads. Structural elements carrying tributary live loads from an area with a *change of occupancy* shall

satisfy the requirements of Section 1607 of the *International Building Code*. Design live loads for areas of new occupancy shall be based on Section 1607 of the *International Building Code*. Design live loads for other areas shall be permitted to use previously *approved* design live loads.

Exception: Structural elements whose demand-capacity ratio considering the *change of occupancy* is not more than 5 percent greater than the demand-capacity ratio based on previously *approved* live loads need not comply with this section.

506.4.2 Snow and wind loads. Where a change of occupancy results in a structure being assigned to a higher *risk category*, the structure shall satisfy the requirements of Sections 1608 and 1609 of the *International Building Code* for the new *risk category*.

Exception: Where the area of the new occupancy is less than 10 percent of the building area, compliance with this section is not required. The cumulative effect of occupancy changes over time shall be considered.

506.4.3 Seismic loads (seismic force-resisting system). Where a *change of occupancy* results in a building being assigned to a higher *risk category*, the building shall satisfy the requirements of Section 1613 of the *International Building Code* for the new *risk category* using full seismic forces.

Exceptions:

1. Where the area of the new occupancy is less than 10 percent of the building area and the new occupancy is not assigned to *Risk Category IV*, compliance with this section is not required. The cumulative effect of occupancy changes over time shall be considered.
2. Where a change of use results in a building being reclassified from *Risk Category I* or *II* to *Risk Category III* and the seismic coefficient, S_{DS} , is less than 0.33, compliance with this section is not required.
3. Unreinforced masonry bearing wall buildings assigned to *Risk Category III* and to Seismic Design Category A or B, shall be permitted to use Appendix Chapter A1 of this code.

506.4.4 Access to Risk Category IV. Any structure that provides operational access to an adjacent structure assigned to *Risk Category IV* as the result of a *change of occupancy* shall itself satisfy the requirements of Sections 1608, 1609 and 1613 of the *International Building Code*. For compliance with Section 1613, *International Building Code*-level seismic forces shall be used. Where operational access to the *Risk Category IV* structure is less than 10 feet (3048 mm) from either an interior lot line or from

another structure, access protection from potential falling debris shall be provided.

**SECTION 507
HISTORIC BUILDINGS**

507.1 Historic buildings. The provisions of this code that require improvements relative to a building's existing condition or, in the case of *repairs*, that require improvements relative to a building's predamage condition, shall not be mandatory for *historic buildings* unless specifically required by this section.

507.2 Life safety hazards. The provisions of this code shall apply to *historic buildings* judged by the building official to constitute a distinct life safety hazard.

[BS] 507.3 Flood hazard areas. Within flood *hazard areas* established in accordance with Section 1612.3 of the *International Building Code*, or Section R322 of the *International Residential Code*, as applicable, where the work proposed constitutes *substantial improvement*, the building shall be brought into compliance with Section 1612 of the *International Building Code*, or Section R322 of the *International Residential Code*, as applicable.

Exception: *Historic buildings* meeting any of the following criteria need not be brought into compliance:

1. Listed or preliminarily determined to be eligible for listing in the National Register of Historic Places.
2. Determined by the Secretary of the U.S. Department of Interior as contributing to the historical significance of a registered historic district or a district preliminarily determined to qualify as an historic district.
3. Designated as historic under a state or local historic preservation program that is *approved* by the Department of Interior.

[BS] 507.4 Structural. Historic buildings shall comply with the applicable structural provisions in this chapter.

Exceptions:

1. The *code official* shall be authorized to accept existing floors and existing live loads and to approve operational controls that limit the live load on any floor.
2. Repair of *substantial structural damage* is not required to comply with Sections 405.2.3, and 405.2.4. *Substantial structural damage* shall be repaired in accordance with Section 405.2.1.



CHAPTER 6

CLASSIFICATION OF WORK

User note:

About this chapter: Chapter 6 provides an overview of the Work Area Method available as an option for rehabilitation of a building. The chapter defines the different classifications of alterations and provides general requirements for alterations, change of occupancy, additions, historic buildings and relocated buildings. Detailed requirements for all of these are given in Chapters 7 through 12.

SECTION 601 GENERAL

601.1 Scope. The provisions of this chapter shall be used in conjunction with Chapters 7 through 12 and shall apply to the *alteration, addition and change of occupancy of existing structures*, including historic and moved structures, as referenced in Section 301.3.2. The work performed on an *existing building* shall be classified in accordance with this chapter.

601.1.1 Compliance with other alternatives. *Alterations, additions and changes of occupancy to existing structures* shall comply with the provisions of Chapters 7 through 12 or with one of the alternatives provided in Section 301.3.

601.2 Work area. The *work area*, as defined in Chapter 2, shall be identified on the construction documents.

SECTION 602 ALTERATION—LEVEL 1

602.1 Scope. Level 1 alterations include the removal and replacement or the covering of existing materials, elements, equipment, or fixtures using new materials, elements, equipment, or fixtures that serve the same purpose.

602.2 Application. Level 1 *alterations* shall comply with the provisions of Chapter 7.

SECTION 603 ALTERATION—LEVEL 2

603.1 Scope. Level 2 *alterations* include the reconfiguration of space, the addition or elimination of any door or window, the reconfiguration or extension of any system, or the installation of any additional equipment.

603.2 Application. Level 2 *alterations* shall comply with the provisions of Chapter 7 for Level 1 *alterations* as well as the provisions of Chapter 8.

SECTION 604 ALTERATION—LEVEL 3

604.1 Scope. Level 3 *alterations* apply where the *work area* exceeds 50 percent of the *building area*.

604.2 Application. Level 3 *alterations* shall comply with the provisions of Chapters 7 and 8 for Level 1 and 2 *alterations*, respectively, as well as the provisions of Chapter 9.

SECTION 605 CHANGE OF OCCUPANCY

605.1 Scope. *Change of occupancy* provisions apply where the activity is classified as a *change of occupancy* as defined in Chapter 2.

605.2 Application. *Changes of occupancy* shall comply with the provisions of Chapter 10.

SECTION 606 ADDITIONS

606.1 Scope. Provisions for *additions* shall apply where work is classified as an *addition* as defined in Chapter 2.

606.2 Application. *Additions to existing buildings* shall comply with the provisions of Chapter 11.

SECTION 607 HISTORIC BUILDINGS

607.1 Scope. *Historic building* provisions shall apply to buildings classified as historic as defined in Chapter 2.

607.2 Application. Except as specifically provided for in Chapter 12, *historic buildings* shall comply with applicable provisions of this code for the type of work being performed.

SECTION 608 RELOCATED BUILDINGS

608.1 Scope. Relocated building provisions shall apply to relocated or moved buildings.

608.2 Application. Relocated buildings shall comply with the provisions of Chapter 14.

CHAPTER 7

ALTERATIONS—LEVEL 1

User note:

About this chapter: Chapter 7 provides the technical requirements for those existing buildings that undergo Level 1 alterations as described in Section 503, which includes replacement or covering of existing materials, elements, equipment or fixtures using new materials for the same purpose. This chapter, similar to other chapters of this code, covers all building-related subjects, such as structural, mechanical, plumbing, electrical and accessibility as well as the fire and life safety issues when the alterations are classified as Level 1. The purpose of this chapter is to provide detailed requirements and provisions to identify the required improvements in the existing building elements, building spaces and building structural system. This chapter is distinguished from Chapters 8 and 9 by involving only replacement of building components with new components. In contrast, Level 2 alterations involve more space reconfiguration, and Level 3 alterations involve more extensive space reconfiguration, exceeding 50 percent of the building area.

SECTION 701 GENERAL

701.1 Scope. Level 1 alterations as described in Section 602 shall comply with the requirements of this chapter. Level 1 alterations to historic buildings shall comply with this chapter, except as modified in Chapter 12.

701.2 Conformance. An existing building or portion thereof shall not be altered such that the building becomes less safe than its existing condition.

Exception: Where the current level of safety or sanitation is proposed to be reduced, the portion altered shall conform to the requirements of the *International Building Code*.

[BS] 701.3 Flood hazard areas. In flood hazard areas, alterations that constitute substantial improvement shall require that the building comply with Section 1612 of the *International Building Code*, or Section R322 of the *International Residential Code*, as applicable.

701.4 Emergency escape and rescue openings. Emergency escape and rescue openings shall be operational from the inside of the room without the use of keys or tools. Bars, grilles, grates or similar devices placed over emergency escape and rescue openings shall comply with the minimum net clear opening size required by the code that was in effect at the time of construction. Such devices shall be releasable or removable from the inside without the use of a key, tool or force greater than that which is required for normal operation of the escape and rescue opening. Where such bars, grilles, grates or similar devices are installed, they shall not reduce the net clear opening of the emergency escape and rescue openings. Smoke alarms shall be installed in accordance with Section 907.2.10 of the *International Building Code* regardless of the valuation of the alteration.

SECTION 702 BUILDING ELEMENTS AND MATERIALS

702.1 Interior finishes. Newly installed interior wall and ceiling finishes shall comply with Chapter 8 of the *International Building Code*.

702.2 Interior floor finish. New interior floor finish, including new carpeting used as an interior floor finish material,

shall comply with Section 804 of the *International Building Code*.

702.3 Interior trim. Newly installed interior trim materials shall comply with Section 806 of the *International Building Code*.

702.4 Window opening control devices on replacement windows. In Group R-2 or R-3 buildings containing dwelling units and one- and two-family dwellings and townhouses regulated by the *International Residential Code*, window opening control devices complying with ASTM F2090 shall be installed where an existing window is replaced and where all of the following apply to the replacement window:

1. The window is operable.
2. The window replacement includes replacement of the sash and the frame.
3. One of the following applies:
 - 3.1. In Group R-2 or R-3 buildings containing dwelling units, the top of the sill of the window opening is at a height less than 36 inches (915 mm) above the finished floor.
 - 3.2. In one- and two-family dwellings and townhouses regulated by the *International Residential Code*, the top sill of the window opening is at a height less than 24 inches (610 mm) above the finished floor.
4. The window will permit openings that will allow passage of a 4-inch-diameter (102 mm) sphere when the window is in its largest opened position.
5. The vertical distance from the top of the sill of the window opening to the finished grade or other surface below, on the exterior of the building, is greater than 72 inches (1829 mm).

The window opening control device, after operation to release the control device allowing the window to fully open, shall not reduce the minimum net clear opening area of the window unit to less than the area required by Section 1030.2 of the *International Building Code*.

Exceptions:

1. Operable windows where the top of the sill of the window opening is located more than 75 feet (22 860 mm)

above the finished grade or other surface below, on the exterior of the room, space or building, and that are provided with window fall prevention devices that comply with ASTM F2006.

2. Operable windows with openings that are provided with window fall prevention devices that comply with ASTM F2090.

702.5 Replacement window emergency escape and rescue openings. Where windows are required to provide emergency escape and rescue openings in Group R-2 and R-3 occupancies and one- and two-family dwellings and townhouses regulated by the *International Residential Code*, replacement windows shall be exempt from the requirements of Sections 1030.2, 1030.3 and 1030.4 of the *International Building Code* and Sections R310.2.1, R310.2.2 and R310.2.3 of the *International Residential Code*, provided that the replacement window meets the following conditions:

1. The replacement window is the manufacturer's largest standard size window that will fit within the existing frame or existing rough opening.
2. The replacement window is not part of a *change of occupancy*.

Window opening control devices complying with ASTM F2090 shall be permitted for use on windows required to provide *emergency escape and rescue openings*.

702.6 Materials and methods. New work shall comply with the materials and methods requirements in the *International Building Code*, *International Energy Conservation Code*, *International Mechanical Code*, and *International Plumbing Code*, as applicable, that specify material standards, detail of installation and connection, joints, penetrations, and continuity of any element, component, or system in the building.

[FG] 702.6.1 International Fuel Gas Code. The following sections of the *International Fuel Gas Code* shall constitute the fuel gas materials and methods requirements for Level 1 *alterations*.

1. Chapter 3, entitled "General Regulations," except Sections 303.7 and 306.
2. Chapter 4, entitled "Gas Piping Installations," except Sections 401.8 and 402.3.
 - 2.1. Sections 401.8 and 402.3 shall apply where the work being performed increases the load on the system such that the existing pipe does not meet the size required by code. Existing systems that are modified shall not require resizing as long as the load on the system is not increased and the system length is not increased even if the altered system does not meet code minimums.
3. Chapter 5, entitled "Chimneys and Vents."
4. Chapter 6, entitled "Specific Appliances."

SECTION 703 FIRE PROTECTION

703.1 General. *Alterations* shall be done in a manner that maintains the level of fire protection provided.

SECTION 704 MEANS OF EGRESS

704.1 General. *Alterations* shall be done in a manner that maintains the level of protection provided for the means of egress.

SECTION 705 REROOFING

[BS] 705.1 General. Materials and methods of application used for recovering or replacing an existing roof covering shall comply with the requirements of Chapter 15 of the *International Building Code*.

Exceptions:

1. *Roof replacement* or roof recover of existing low-slope roof coverings shall not be required to meet the minimum design slope requirement of one-quarter unit vertical in 12 units horizontal (2-percent slope) in Section 1507 of the *International Building Code* for roofs that provide positive roof drainage.
2. Recovering or replacing an existing roof covering shall not be required to meet the requirement for secondary (emergency overflow) drains or scuppers in Section 1502 of the *International Building Code* for roofs that provide for positive roof drainage. For the purposes of this exception, existing secondary drainage or scupper systems required in accordance with this code shall not be removed unless they are replaced by secondary drains or scuppers designed and installed in accordance with Section 1502 of the *International Building Code*.

[BS] 705.2 Structural and construction loads. Structural roof components shall be capable of supporting the roof-covering system and the material and equipment loads that will be encountered during installation of the system.

[BS] 705.3 Roof replacement. *Roof replacement* shall include the removal of all existing layers of roof coverings down to the roof deck.

Exception: Where the existing roof assembly includes an ice barrier membrane that is adhered to the roof deck, the existing ice barrier membrane shall be permitted to remain in place and covered with an additional layer of ice barrier membrane in accordance with Section 1507 of the *International Building Code*.

[BS] 705.3.1 Roof recover. The installation of a new roof covering over an existing roof covering shall be permitted where any of the following conditions occur:

1. The new roof covering is installed in accordance with the roof covering manufacturer's *approved* instructions.
2. Complete and separate roofing systems, such as standing-seam metal roof panel systems, that are designed to transmit the roof loads directly to the building's structural system and that do not rely on existing roofs and roof coverings for support, are installed.

3. Metal panel, metal shingle and concrete and clay tile roof coverings are installed over existing wood shake roofs in accordance with Section 705.4.
4. A new protective *roof coating* is applied over an existing protective *roof coating*, a metal roof panel, metal roof shingles, mineral-surfaced roll roofing, a built-up roof, modified bitumen roofing, thermoset and thermoplastic single-ply roofing or a spray polyurethane foam roofing system.

[BS] 705.3.1.1 Exceptions. A roof recover shall not be permitted where any of the following conditions occur:

1. The existing roof or roof covering is water soaked or has deteriorated to the point that the existing roof or roof covering is not adequate as a base for additional roofing.
2. The existing roof covering is slate, clay, cement or asbestos-cement tile.
3. The existing roof has two or more applications of any type of roof covering.

[BS] 705.4 Roof recovering. Where the application of a new roof covering over wood shingle or shake roofs creates a combustible concealed space, the entire existing surface shall be covered with gypsum board, mineral fiber, glass fiber or other *approved* materials securely fastened in place.

[BS] 705.5 Reinstallation of materials. Existing slate, clay or cement tile shall be permitted for reinstallation, except that damaged, cracked or broken slate or tile shall not be reinstalled. Existing vent flashing, metal edgings, drain outlets, collars and metal counterflashings shall not be reinstalled where rusted, damaged or deteriorated. Aggregate surfacing materials shall not be reinstalled.

[BS] 705.6 Flashings. Flashings shall be reconstructed in accordance with *approved* manufacturer's installation instructions. Metal flashing to which bituminous materials are to be adhered shall be primed prior to installation.

SECTION 706 STRUCTURAL

[BS] 706.1 General. Where *alteration* work includes replacement of equipment that is supported by the building or where a reroofing permit is required, the provisions of this section shall apply.

[BS] 706.2 Addition or replacement of roofing or replacement of equipment. Any existing gravity load-carrying structural element for which an *alteration* causes an increase in design dead, live or snow load, including snow drift effects, of more than 5 percent shall be replaced or altered as needed to carry the gravity loads required by the *International Building Code* for new structures.

Exceptions:

1. Buildings of Group R occupancy with not more than five dwelling or sleeping units used solely for residential purposes where the altered building complies with the conventional light-frame construction methods of the *International Building Code* or the provisions of the *International Residential Code*.

2. Buildings in which the increased dead load is due entirely to the addition of a second layer of roof covering weighing 3 pounds per square foot (0.1437 kN/m²) or less over an existing single layer of roof covering.

[BS] 706.3 Additional requirements for reroof permits. The requirements of this section shall apply to *alteration* work requiring reroof permits.

[BS] 706.3.1 Bracing for unreinforced masonry bearing wall parapets. Where a permit is issued for reroofing for more than 25 percent of the roof area of a building assigned to Seismic Design Category D, E or F that has parapets constructed of unreinforced masonry, the work shall include installation of parapet bracing unless an evaluation demonstrates compliance of such items. Reduced seismic forces shall be permitted.

[BS] 706.3.2 Roof diaphragms resisting wind loads in high-wind regions. Where roofing materials are removed from more than 50 percent of the roof diaphragm or section of a building located where the ultimate design wind speed, V_{ult} , determined in accordance with Figure 1609.3(1) of the *International Building Code*, is greater than 115 mph (51 m/s) or in a special wind region, as defined in Section 1609 of the *International Building Code*, roof diaphragms, connections of the roof diaphragm to roof framing members, and roof-to-wall connections shall be evaluated for the wind loads specified in the *International Building Code*, including wind uplift. If the diaphragms and connections in their current condition are not capable of resisting 75 percent of those wind loads, they shall be replaced or strengthened in accordance with the loads specified in the *International Building Code*.

SECTION 707 ENERGY CONSERVATION

707.1 Minimum requirements. Level 1 *alterations* to existing buildings or structures do not require the entire building or structure to comply with the energy requirements of the *International Energy Conservation Code* or *International Residential Code*. The *alterations* shall conform to the energy requirements of the *International Energy Conservation Code* or *International Residential Code* as they relate to new construction only.

CHAPTER 8

ALTERATIONS—LEVEL 2

User note:

About this chapter: Like Chapter 7, the purpose of this chapter is to provide detailed requirements and provisions to identify the required improvements in the existing building elements, building spaces and building structural system when a building is being altered. This chapter is distinguished from Chapters 7 and 9 by involving space reconfiguration that could be up to and including 50 percent of the area of the building. In contrast, Level 1 alterations (Chapter 7) do not involve space reconfiguration, and Level 3 alterations (Chapter 9) involve extensive space reconfiguration that exceeds 50 percent of the building area. Depending on the nature of alteration work, its location within the building, and whether it encompasses one or more tenants, improvements and upgrades could be required for the open floor penetrations, sprinkler system or the installation of additional means of egress such as stairs or fire escapes.

SECTION 801 GENERAL

801.1 Scope. Level 2 alterations as described in Section 603 shall comply with the requirements of this chapter.

Exception: Buildings in which the reconfiguration is exclusively the result of compliance with the accessibility requirements of Section 305.7 shall be permitted to comply with Chapter 7.

801.2 Alteration Level 1 compliance. In addition to the requirements of this chapter, all work shall comply with the requirements of Chapter 7.

801.3 Compliance. New construction elements, components, systems, and spaces shall comply with the requirements of the *International Building Code*.

Exceptions:

1. Where windows are added they are not required to comply with the light and ventilation requirements of the *International Building Code*.
2. Newly installed electrical equipment shall comply with the requirements of Section 807.
3. The length of dead-end corridors in newly constructed spaces shall only be required to comply with the provisions of Section 805.6.
4. The minimum ceiling height of the newly created habitable and occupiable spaces and corridors shall be 7 feet (2134 mm).
5. Where provided in below-grade transportation stations, existing and new escalators shall be permitted to have a clear width of less than 32 inches (815 mm).
6. New structural members and connections shall be permitted to comply with alternative design criteria in accordance with Section 302.

SECTION 802 BUILDING ELEMENTS AND MATERIALS

802.1 Scope. The requirements of this section are limited to *work areas* in which Level 2 alterations are being performed and shall apply beyond the work area where specified.

802.2 Vertical openings. Existing vertical openings shall comply with the provisions of Sections 802.2.1, 802.2.2 and 802.2.3.

802.2.1 Existing vertical openings. Existing interior vertical openings connecting two or more floors shall be enclosed with *approved* assemblies having a fire-resistance rating of not less than 1 hour with *approved* opening protectives.

Exceptions:

1. Where vertical opening enclosure is not required by the *International Building Code* or the *International Fire Code*.
2. Interior vertical openings other than stairways may be blocked at the floor and ceiling of the *work area* by installation of not less than 2 inches (51 mm) of solid wood or equivalent construction.
3. The enclosure shall not be required where:
 - 3.1. Connecting the main floor and mezzanines; or
 - 3.2. All of the following conditions are met:
 - 3.2.1. The communicating area has a low-hazard occupancy or has a moderate-hazard occupancy that is protected throughout by an automatic sprinkler system.
 - 3.2.2. The lowest or next-to-the-lowest level is a street floor.
 - 3.2.3. The entire area is open and unobstructed in a manner such that it is reasonable to assume that a fire in any part of the interconnected spaces will be readily obvious to all of the occupants.
 - 3.2.4. Exit capacity is sufficient to provide egress simultaneously for all occupants of all levels by considering all areas to be a single floor area for the determination of required exit capacity.
 - 3.2.5. Each floor level, considered separately, has not less than one-half of its individual

14. Group S occupancies where vertical opening protection is not required for open parking garages and ramps.

802.2.2 Supplemental shaft and floor opening enclosure requirements. Where the *work area* on any floor exceeds 50 percent of that floor area, the enclosure requirements of Section 802.2 shall apply to vertical openings other than stairways throughout the floor.

Exception: Vertical openings located in tenant spaces that are entirely outside the *work area*.

802.2.3 Supplemental stairway enclosure requirements. Where the *work area* on any floor exceeds 50 percent of that floor area, stairways that are part of the means of egress serving the *work area* shall, at a minimum, be enclosed with smoke-tight construction on the highest *work area* floor and all floors below.

Exception: Where stairway enclosure is not required by the *International Building Code* or the *International Fire Code*.

802.3 Smoke compartments. In Group I-2 occupancies where the *work area* is on a story used for sleeping rooms for more than 30 patients, the story shall be divided into not less than two compartments by smoke barrier walls in accordance with Section 407.5 of the *International Building Code* as required for new construction.

802.4 Interior finish. The interior finish of walls and ceilings in exits and corridors in any *work area* shall comply with the requirements of the *International Building Code*.

Exception: Existing interior finish materials that do not comply with the interior finish requirements of the *International Building Code* shall be permitted to be treated with an *approved* fire-retardant coating in accordance with the manufacturer's instructions to achieve the required rating.

802.4.1 Supplemental interior finish requirements. Where the *work area* on any floor exceeds 50 percent of the floor area, Section 802.4 shall apply to the interior finish in exits and corridors serving the *work area* throughout the floor.

Exception: Interior finish within tenant spaces that are entirely outside the *work area*.

802.5 Guards. The requirements of Sections 802.5.1 and 802.5.2 shall apply in all *work areas*.

802.5.1 Minimum requirement. Every portion of a floor, such as a balcony or a loading dock, that is more than 30 inches (762 mm) above the floor or grade below and is not provided with guards, or those in which the existing guards are judged to be in danger of collapsing, shall be provided with guards.

802.5.2 Design. Where there are no guards or where existing guards must be replaced, the guards shall be designed and installed in accordance with the *International Building Code*.

802.6 Fire-resistance ratings. Where *approved* by the *code official*, buildings where an automatic sprinkler system installed in accordance with Section 903.3.1.1 or 903.3.1.2 of

the *International Building Code* has been added, and the building is now sprinklered throughout, the required fire-resistance ratings of building elements and materials shall be permitted to meet the requirements of the current building code. The building is required to meet the other applicable requirements of the *International Building Code*.

Plans, investigation and evaluation reports, and other data shall be submitted indicating which building elements and materials the applicant is requesting the *code official* to review and approve for determination of applying the current building code fire-resistance ratings. Any special construction features, including fire-resistance-rated assemblies and smoke-resistive assemblies, conditions of occupancy, means-of-egress conditions, fire code deficiencies, *approved* modifications or *approved* alternative materials, design and methods of construction, and equipment applying to the building that impact required fire-resistance ratings shall be identified in the evaluation reports submitted.

SECTION 803 FIRE PROTECTION

803.1 Scope. The requirements of this section shall be limited to *work areas* in which Level 2 *alterations* are being performed, and where specified they shall apply throughout the floor on which the *work areas* are located or otherwise beyond the *work area*.

803.1.1 Corridor ratings. Where an *approved* automatic sprinkler system is installed throughout the story, the required fire-resistance rating for any corridor located on the story shall be permitted to be reduced in accordance with the *International Building Code*. In order to be considered for a corridor rating reduction, such system shall provide coverage for the stairway landings serving the floor and the intermediate landings immediately below.

803.2 Automatic sprinkler systems. Automatic sprinkler systems shall be provided in accordance with the requirements of Sections 803.2.1 through 803.2.4. Installation requirements shall be in accordance with the *International Building Code*.

803.2.1 High-rise buildings. In high-rise buildings, *work areas* that have exits or corridors shared by more than one tenant or that have exits or corridors serving an occupant load greater than 30 shall be provided with automatic sprinkler protection in the entire *work area* where the *work area* is located on a floor that has a sufficient sprinkler water supply system from an existing standpipe or a sprinkler riser serving that floor.

803.2.1.1 Supplemental automatic sprinkler system requirements. Where the *work area* on any floor exceeds 50 percent of that floor area, Section 803.2.1 shall apply to the entire floor on which the *work area* is located.

Exception: Occupied tenant spaces that are entirely outside the *work area*.

803.2.2 Groups A, B, E, F-1, H, I, M, R-1, R-2, R-4, S-1 and S-2. In buildings with occupancies in Groups A, B, E,

803.4.1.2 Group I-1. A fire alarm system shall be installed in *work areas* of Group I-1 residential care/assisted living facilities as required by the *International Fire Code* for existing Group I-1 occupancies.

803.4.1.3 Group I-2. A fire alarm system shall be installed throughout Group I-2 occupancies as required by the *International Fire Code*.

803.4.1.4 Group I-3. A fire alarm system shall be installed in *work areas* of Group I-3 occupancies as required by the *International Fire Code*.

803.4.1.5 Group R-1. A fire alarm system shall be installed in Group R-1 occupancies as required by the *International Fire Code* for existing Group R-1 occupancies.

803.4.1.6 Group R-2. A fire alarm system shall be installed in *work areas* of Group R-2 apartment buildings as required by the *International Fire Code* for existing Group R-2 occupancies.

803.4.2 Supplemental fire alarm system requirements. Where the *work area* on any floor exceeds 50 percent of that floor area, Section 803.4.1 shall apply throughout the floor.

Exception: Alarm-initiating and notification appliances shall not be required to be installed in tenant spaces outside of the *work area*.

803.4.3 Smoke alarms. Individual sleeping units and individual dwelling units in any *work area* in Group R and I-1 occupancies shall be provided with smoke alarms in accordance with the *International Fire Code*.

Exception: Interconnection of smoke alarms outside of the *work area* shall not be required.

SECTION 804 CARBON MONOXIDE DETECTION

804.1 Carbon monoxide alarms. Any *work area* in Group I-1, I-2, I-4 and R occupancies shall be equipped with carbon monoxide alarms in accordance with Section 1103.9 of the *International Fire Code*.

Exceptions:

1. Work involving the exterior surfaces of buildings, such as the replacement of roofing or siding, the addition or replacement of windows or doors, or the addition of porches or decks.
2. Installation, alteration or *repairs* of plumbing or mechanical systems, other than fuel-burning appliances.

SECTION 805 MEANS OF EGRESS

805.1 Scope. The requirements of this section shall be limited to *work areas* that include exits or corridors shared by more than one tenant within the *work area* in which Level 2 alterations are being performed, and where specified they shall apply throughout the floor on which the *work areas* are located or otherwise beyond the *work area*.

805.2 General. The means of egress shall comply with the requirements of this section.

Exceptions:

1. Where the *work area* and the means of egress serving it complies with NFPA 101.
2. Means of egress complying with the requirements of the building code under which the building was constructed shall be considered to be compliant means of egress if, in the opinion of the *code official*, they do not constitute a distinct hazard to life.

805.3 Number of exits. The number of exits shall be in accordance with Sections 805.3.1 through 805.3.3.

805.3.1 Minimum number. Every story utilized for human occupancy on which there is a *work area* that includes exits or corridors shared by more than one tenant within the *work area* shall be provided with the minimum number of exits based on the occupancy and the occupant load in accordance with the *International Building Code*. In addition, the exits shall comply with Sections 805.3.1.1 and 805.3.1.2.

805.3.1.1 Single-exit buildings. A single exit or access to a single exit shall be permitted from spaces, any story or any occupied roof where one of the following conditions exists:

1. The occupant load, number of dwelling units and exit access travel distance do not exceed the values in Table 805.3.1.1(1) or 805.3.1.1(2).
2. In Group R-1 or R-2, nonsprinklered buildings, individual single-story or multiple-story dwelling or sleeping units shall be permitted to have a single exit or access to a single exit from the dwelling or sleeping unit provided one of the following criteria are met:
 - 2.1. The occupant load is not greater than 10 and the exit access travel distance within the unit does not exceed 75 feet (22 860 mm).
 - 2.2. The building is not more than three stories in height; all third-story space is part of dwelling with an exit access doorway on the second story; and the portion of the exit access travel distance from the door to any habitable room within any such unit to the unit entrance doors does not exceed 50 feet (15 240 mm).
3. In buildings of Group R-2 occupancy of any number of stories with not more than four dwelling units per floor served by an interior exit stairway; with a smokeproof enclosure in accordance with Sections 909.20 and 1023.11 of the *International Building Code* or an exterior stairway as an exit; and where the portion of the exit access travel distance from the dwelling unit entrance door to the exit is not greater than 20 feet (6096 mm).

805.3.1.2 Fire escapes required. For other than Group I-2, where more than one exit is required, an existing or newly constructed fire escape complying with Section

TABLE 805.3.1.1(1)
STORIES WITH ONE EXIT OR ACCESS TO ONE EXIT
FOR R-2 OCCUPANCIES

STORY	OCCUPANCY	MAXIMUM NUMBER OF DWELLING UNITS	MAXIMUM EXIT ACCESS TRAVEL DISTANCE (feet)
Basement, first or second story above grade plane	R-2 ^a	4 dwelling units	50
Third story above grade plane and higher	NP	NA	NA

For SI: 1 foot = 304.8 mm.

NP = Not Permitted.

NA = Not Applicable.

a. Group R-2, nonsprinklered and provided with emergency escape and rescue openings in accordance with Section 1030 of the *International Building Code*.

TABLE 805.3.1.1(2)
STORIES WITH ONE EXIT OR ACCESS TO ONE EXIT
FOR OTHER OCCUPANCIES

STORY	OCCUPANCY	MAXIMUM OCCUPANT LOAD PER STORY	MAXIMUM EXIT ACCESS TRAVEL DISTANCE (feet)
First story above or below grade plane	B, F-2, S-2 ^a	35	75
Second story above grade plane	B, F-2, S-2 ^a	35	75
Third story above grade plane and higher	NP	NA	NA

For SI: 1 foot = 304.8 mm.

NP = Not Permitted.

NA = Not Applicable.

a. The length of exit access travel distance in a Group S-2 open parking garage shall be not more than 100 feet.

805.3.1.2.1 shall be accepted as providing one of the required means of egress.

805.3.1.2.1 Fire escape access and details. Fire escapes shall comply with all of the following requirements:

1. Occupants shall have unobstructed access to the fire escape without having to pass through a room subject to locking.
2. Access to a new fire escape shall be through a door, except that windows shall be permitted to provide access from single dwelling units or sleeping units in Group R-1, R-2 and I-1 occupancies or to provide access from spaces having a maximum occupant load of 10 in other occupancy classifications.
 - 2.1. The window shall have a minimum net clear opening of 5.7 square feet (0.53 m²) or 5 square feet (0.46 m²) where located at grade.
 - 2.2. The minimum net clear opening height shall be 24 inches (610 mm) and net clear opening width shall be 20 inches (508 mm).

2.3. The bottom of the clear opening shall not be greater than 44 inches (1118 mm) above the floor.

2.4. The operation of the window shall comply with the operational constraints of the *International Building Code*.

3. Newly constructed fire escapes shall be permitted only where exterior stairways cannot be utilized because of lot lines limiting the stairway size or because of the sidewalks, alleys, or roads at grade level.
4. Openings within 10 feet (3048 mm) of fire escape stairways shall be protected by fire assemblies having minimum 3/4-hour fire-resistance ratings.

Exception: Opening protection shall not be required in buildings equipped throughout with an *approved* automatic sprinkler system.

5. In all buildings of Group E occupancy, up to and including the 12th grade, buildings of Group I occupancy, rooming houses and childcare centers, ladders of any type are prohibited on fire escapes used as a required means of egress.

provided with handrails for the full length of the stairway on not fewer than one side. Exit stairways with a required egress width of more than 66 inches (1676 mm) shall have handrails on both sides.

805.9.2 Design. Handrails required in accordance with Section 805.9.1 shall be designed and installed in accordance with the provisions of the *International Building Code*.

805.10 Refuge areas. Where *alterations* affect the configuration of an area utilized as a refuge area, the capacity of the refuge area shall not be reduced below that required in Sections 805.10.1 and 805.10.2.

805.10.1 Capacity. The required capacity of refuge areas shall be in accordance with Sections 805.10.1.1 through 805.10.1.3.

805.10.1.1 Group I-2. In Group I-2 occupancies, the required capacity of the refuge areas for smoke compartments in accordance with Section 407.5.1 of the *International Building Code* shall be maintained.

805.10.1.2 Group I-3. In Group I-3 occupancies, the required capacity of the refuge areas for smoke compartments in accordance with Section 408.6.2 of the *International Building Code* shall be maintained.

805.10.1.3 Ambulatory care. In ambulatory care facilities required to be separated by Section 422.2 of the *International Building Code*, the required capacity of the refuge areas for smoke compartments in accordance with Section 422.3.2 of the *International Building Code* shall be maintained.

805.10.2 Horizontal exits. The required capacity of the refuge area for horizontal exits in accordance with Section 1026.4 of the *International Building Code* shall be maintained.

805.11 Guards. The requirements of Sections 805.11.1 and 805.11.2 shall apply to guards from the *work area* floor to, and including, the level of exit discharge but shall be confined to the egress path of any *work area*.

805.11.1 Minimum requirement. Every open portion of a stairway, landing, or balcony that is more than 30 inches (762 mm) above the floor or grade below and is not provided with guards, or those portions in which existing guards are judged to be in danger of collapsing, shall be provided with guards.

805.11.2 Design. Guards required in accordance with Section 805.11.1 shall be designed and installed in accordance with the *International Building Code*.

SECTION 806 STRUCTURAL

[BS] 806.1 General. Structural elements and systems within buildings undergoing Level 2 *alterations* shall comply with this section.

[BS] 806.2 Existing structural elements carrying gravity loads. Any existing gravity load-carrying structural element for which an *alteration* causes an increase in design dead, live or snow load, including snow drift effects, of more than 5 percent shall be replaced or altered as needed to carry the

gravity loads required by the *International Building Code* for new structures. Any existing gravity load-carrying structural element whose gravity load-carrying capacity is decreased as part of the *alteration* shall be shown to have the capacity to resist the applicable design dead, live and snow loads, including snow drift effects, required by the *International Building Code* for new structures.

Exceptions:

1. Buildings of Group R occupancy with not more than five dwelling or sleeping units used solely for residential purposes where the altered building complies with the conventional light-frame construction methods of the *International Building Code* or the provisions of the *International Residential Code*.
2. Buildings in which the increased dead load is attributable to the addition of a second layer of roof covering weighing 3 pounds per square foot (0.1437 kN/m²) or less over an existing single layer of roof covering.

[BS] 806.3 Existing structural elements resisting lateral loads. Except as permitted by Section 806.4, where the *alteration* increases design lateral loads, or where the alteration results in prohibited structural irregularity as defined in ASCE 7, or where the *alteration* decreases the capacity of any existing lateral load-carrying structural element, the structure of the altered building or structure shall meet the requirements of Sections 1609 and 1613 of the *International Building Code*. Reduced seismic forces shall be permitted.

Exception: Any existing lateral load-carrying structural element whose demand-capacity ratio with the *alteration* considered is not more than 10 percent greater than its demand-capacity ratio with the *alteration* ignored shall be permitted to remain unaltered. For purposes of calculating demand-capacity ratios, the demand shall consider applicable load combinations with design lateral loads or forces in accordance with Sections 1609 and 1613 of the *International Building Code*. Reduced seismic forces shall be permitted. For purposes of this exception, comparisons of demand-capacity ratios and calculation of design lateral loads, forces and capacities shall account for the cumulative effects of *additions* and *alterations* since original construction.

[BS] 806.4 Voluntary lateral force-resisting system alterations. Structural *alterations* that are intended exclusively to improve the lateral force-resisting system and are not required by other sections of this code shall not be required to meet the requirements of Section 1609 or Section 1613 of the *International Building Code*, provided that the following conditions are met:

1. The capacity of existing structural systems to resist forces is not reduced.
2. New structural elements are detailed and connected to existing or new structural elements as required by the *International Building Code* for new construction.
3. New or relocated nonstructural elements are detailed and connected to existing or new structural elements as required by the *International Building Code* for new construction.

4. The *alterations* do not create a structural irregularity as defined in ASCE 7 or make an existing structural irregularity more severe.

SECTION 807 ELECTRICAL

807.1 New installations. Newly installed electrical equipment and wiring relating to work done in any *work area* shall comply with all applicable requirements of NFPA 70 except as provided for in Section 807.3.

807.2 Existing installations. Existing wiring in all *work areas* in Group A-1, A-2, A-5, H and I occupancies shall be upgraded to meet the materials and methods requirements of Chapter 7.

807.3 Residential occupancies. In Group R-2, R-3 and R-4 occupancies and buildings regulated by the *International Residential Code*, the requirements of Sections 807.3.1 through 807.3.7 shall be applicable only to *work areas* located within a dwelling unit.

807.3.1 Enclosed areas. Enclosed areas, other than closets, kitchens, basements, garages, hallways, laundry areas, utility areas, storage areas and bathrooms shall have not fewer than two duplex receptacle outlets or one duplex receptacle outlet and one ceiling or wall-type lighting outlet.

807.3.2 Kitchens. Kitchen areas shall have not fewer than two duplex receptacle outlets.

807.3.3 Laundry areas. Laundry areas shall have not fewer than one duplex receptacle outlet located near the laundry equipment and installed on an independent circuit.

807.3.4 Ground fault circuit interruption. Newly installed receptacle outlets shall be provided with ground fault circuit interruption as required by NFPA 70.

807.3.5 Minimum lighting outlets. Not fewer than one lighting outlet shall be provided in every bathroom, hallway, stairway, attached garage, and detached garage with electric power, and to illuminate outdoor entrances and exits.

807.3.6 Utility rooms and basements. Not fewer than one lighting outlet shall be provided in utility rooms and basements where such spaces are used for storage or contain equipment requiring service.

807.3.7 Clearance for equipment. Clearance for electrical service equipment shall be provided in accordance with the NFPA 70.

SECTION 808 MECHANICAL

808.1 Reconfigured or converted spaces. Reconfigured spaces intended for occupancy and spaces converted to habitable or occupiable space in any *work area* shall be provided with natural or mechanical ventilation in accordance with the *International Mechanical Code*.

Exception: Existing mechanical ventilation systems shall comply with the requirements of Section 808.2.

808.2 Altered existing systems. In mechanically ventilated spaces, existing mechanical ventilation systems that are altered, reconfigured, or extended shall provide not less than 5 cubic feet per minute (cfm) (0.0024 m³/s) per person of outdoor air and not less than 15 cfm (0.0071 m³/s) of ventilation air per person; or not less than the amount of ventilation air determined by the Indoor Air Quality Procedure of ASHRAE 62.1.

808.3 Local exhaust. Newly introduced devices, equipment, or operations that produce airborne particulate matter, odors, fumes, vapor, combustion products, gaseous contaminants, pathogenic and allergenic organisms, and microbial contaminants in such quantities as to affect adversely or impair health or cause discomfort to occupants shall be provided with local exhaust.

SECTION 809 PLUMBING

809.1 Minimum fixtures. Where the occupant load of the story is increased by more than 20 percent, plumbing fixtures for the story shall be provided in quantities specified in the *International Plumbing Code* based on the increased occupant load.

SECTION 810 ENERGY CONSERVATION

810.1 Minimum requirements. Level 2 *alterations* to existing buildings or structures are permitted without requiring the entire building or structure to comply with the energy requirements of the *International Energy Conservation Code* or *International Residential Code*. The *alterations* shall conform to the energy requirements of the *International Energy Conservation Code* or *International Residential Code* as they relate to new construction only.

CHAPTER 9

ALTERATIONS—LEVEL 3

User note:

About this chapter: Chapter 9 provides the technical requirements for those existing buildings that undergo Level 3 alterations. The purpose of this chapter is to provide detailed requirements and provisions to identify the required improvements in the existing building elements, building spaces and building structural system. This chapter is distinguished from Chapters 7 and 8 by involving alterations that cover 50 percent or more of the aggregate area of the building. In contrast, Level 1 alterations do not involve space reconfiguration, and Level 2 alterations involve extensive space reconfiguration that does not exceed 50 percent of the building area. Depending on the nature of alteration work, its location within the building, and whether it encompasses one or more tenants, improvements and upgrades could be required for the open floor penetrations, sprinkler system or the installation of additional means of egress such as stairs or fire escapes. At times and under certain situations, this chapter also is intended to improve the safety of certain building features beyond the work area and in other parts of the building where no alteration work might be taking place.

SECTION 901 GENERAL

901.1 Scope. Level 3 alterations as described in Section 604 shall comply with the requirements of this chapter.

901.2 Compliance. In addition to the provisions of this chapter, work shall comply with all of the requirements of Chapters 7 and 8. The requirements of Sections 802, 803, and 804 shall apply within all *work areas* whether or not they include exits and corridors shared by more than one tenant and regardless of the occupant load.

Exception: Buildings in which the reconfiguration of space affecting exits or shared egress access is exclusively the result of compliance with the accessibility requirements of Section 305.7 shall not be required to comply with this chapter.

SECTION 902 SPECIAL USE AND OCCUPANCY

902.1 High-rise buildings. Any building having occupied floors more than 75 feet (22 860 mm) above the lowest level of fire department vehicle access shall comply with the requirements of Sections 902.1.1 and 902.1.2.

902.1.1 Recirculating air or exhaust systems. Where a floor is served by a recirculating air or exhaust system with a capacity greater than 15,000 cubic feet per minute (701 m³/s), that system shall be equipped with *approved* smoke and heat detection devices installed in accordance with the *International Mechanical Code*.

902.1.2 Elevators. Where there is an elevator or elevators for public use, not fewer than one elevator serving the *work area* shall comply with this section. Existing elevators with a travel distance of 25 feet (7620 mm) or more above or below the main floor or other level of a building and intended to serve the needs of emergency personnel for fire-fighting or rescue purposes shall be provided with emergency operation in accordance with ASME A17.3. New elevators shall be provided with Phase I emergency recall operation and Phase II emergency in-car operation in accordance with ASME A17.1/CSAB44.1.

902.2 Boiler and furnace equipment rooms. Boiler and furnace equipment rooms adjacent to or within Group I-1, I-2, I-4, R-1, R-2 and R-4 occupancies shall be enclosed by 1-hour fire-resistance-rated construction.

Exceptions:

1. Steam boiler equipment operating at pressures of 15 pounds per square inch gauge (psig) (103.4 kPa) or less is not required to be enclosed.
2. Hot water boilers operating at pressures of 170 psig (1171 kPa) or less are not required to be enclosed.
3. Furnace and boiler equipment with 400,000 British thermal units (Btu) (4.22 × 10⁸ J) per hour input rating or less is not required to be enclosed.
4. Furnace rooms protected with an automatic sprinkler system are not required to be enclosed.

SECTION 903 BUILDING ELEMENTS AND MATERIALS

903.1 Existing shafts and vertical openings. Existing stairways that are part of the means of egress shall be enclosed in accordance with Section 802.2.1 from the highest *work area* floor to, and including, the level of exit discharge and all floors below.

903.2 Fire partitions in Group R-3. Fire separation in Group R-3 occupancies shall be in accordance with Section 903.2.1.

903.2.1 Separation required. Where the *work area* is in any attached dwelling unit in Group R-3 or any multiple single-family dwelling (townhouse), walls separating the dwelling units that are not continuous from the foundation to the underside of the roof sheathing shall be constructed to provide a continuous fire separation using construction materials consistent with the existing wall or complying with the requirements for new structures. Work shall be performed on the side of the dwelling unit wall that is part of the *work area*.

Exception: Where *alterations* or *repairs* do not result in the removal of wall or ceiling finishes exposing the structure, walls are not required to be continuous through concealed floor spaces.

903.3 Interior finish. Interior finish in exits serving the *work area* shall comply with Section 802.4 between the highest floor on which there is a *work area* to the floor of exit discharge.

**SECTION 904
FIRE PROTECTION**

904.1 Automatic sprinkler systems. An automatic sprinkler system shall be provided in a *work area* where required by Section 802.2 or this section.

904.1.1 High-rise buildings. An automatic sprinkler system shall be provided in *work areas* where the high-rise building has a sufficient municipal water supply for the design and installation of an automatic sprinkler system at the site.

904.1.2 Rubbish and linen chutes. Rubbish and linen chutes located in the *work area* shall be provided with automatic sprinkler system protection or an *approved* automatic fire-extinguishing system where protection of the rubbish and linen chute would be required under the provisions of the *International Building Code* for new construction.

904.1.3 Upholstered furniture or mattresses. *Work areas* shall be provided with an automatic sprinkler system in accordance with the *International Building Code* where any of the following conditions exist:

1. A Group F-1 occupancy used for the manufacture of upholstered furniture or mattresses exceeds 2,500 square feet (232 m²).
2. A Group M occupancy used for the display and sale of upholstered furniture or mattresses exceeds 5,000 square feet (464 m²).
3. A Group S-1 occupancy used for the storage of upholstered furniture or mattresses exceeds 2,500 square feet (232 m²).

904.1.4 Other required automatic sprinkler systems. In buildings and areas listed in Table 903.2.11.6 of the *International Building Code*, *work areas* that have exits or corridors shared by more than one tenant or that have exits or corridors serving an occupant load greater than 30 shall be provided with an automatic sprinkler system under the following conditions:

1. The *work area* is required to be provided with an automatic sprinkler system in accordance with the *International Building Code* applicable to new construction.
2. The building site has sufficient municipal water supply for design and installation of an automatic sprinkler system.

904.2 Fire alarm and detection systems. Fire alarm and detection shall be provided in accordance with Section 907 of the *International Building Code* as required for new construction.

904.2.1 Manual fire alarm systems. Where required by the *International Building Code*, a manual fire alarm sys-

tem shall be provided throughout the *work area*. Alarm notification appliances shall be provided on such floors and shall be automatically activated as required by the *International Building Code*.

Exceptions:

1. Alarm-initiating and notification appliances shall not be required to be installed in tenant spaces outside of the *work area*.
2. Visual alarm notification appliances are not required, except where an existing alarm system is upgraded or replaced or where a new fire alarm system is installed.

904.2.2 Automatic fire detection. Where required by the *International Building Code* for new buildings, automatic fire detection systems shall be provided throughout the *work area*.

**SECTION 905
MEANS OF EGRESS**

905.1 General. The means of egress shall comply with the requirements of Section 805 except as specifically required in Sections 905.2 and 905.3.

905.2 Means-of-egress lighting. Means of egress from the highest *work area* floor to the floor of exit discharge shall be provided with artificial lighting within the exit enclosure in accordance with the requirements of the *International Building Code*.

905.3 Exit signs. Means of egress from the highest *work area* floor to the floor of exit discharge shall be provided with exit signs in accordance with the requirements of the *International Building Code*.

**SECTION 906
STRUCTURAL**

[BS] 906.1 General. Where buildings are undergoing Level 3 alterations, the provisions of this section shall apply.

[BS] 906.2 Existing structural elements resisting lateral loads. Where work involves a *substantial structural alteration*, the lateral load-resisting system of the altered building shall be shown to satisfy the requirements of Sections 1609 and 1613 of the *International Building Code*. Reduced seismic forces shall be permitted.

Exceptions:

1. Buildings of Group R occupancy with not more than five dwelling or sleeping units used solely for residential purposes that are altered based on the conventional light-frame construction methods of the *International Building Code* or in compliance with the provisions of the *International Residential Code*.
2. Where the intended *alteration* involves only the lowest story of a building, only the lateral load-resisting components in and below that story need comply with this section.

**

[BS] 906.3 Seismic Design Category F. Where the building is assigned to Seismic Design Category F, the structure of the altered building shall meet the requirements of Sections 1609 and 1613 of the *International Building Code*. Reduced seismic forces shall be permitted.

[BS] 906.4. Anchorage for concrete and masonry buildings. For any building assigned to Seismic Design Category D, E or F with a structural system that includes concrete or reinforced masonry walls with a flexible roof diaphragm, the *alteration* work shall include installation of wall anchors at the roof line of all subject buildings and at the floor lines of unreinforced masonry buildings unless an evaluation demonstrates compliance of existing wall anchorage. Reduced seismic forces shall be permitted.

[BS] 906.5 Anchorage for unreinforced masonry walls. For any building assigned to Seismic Design Category C, D, E or F with a structural system that includes unreinforced masonry bearing walls, the *alteration* work shall include installation of wall anchors at the roof line, unless an evaluation demonstrates compliance of existing wall anchorage. Reduced seismic forces shall be permitted.

[BS] 906.6 Bracing for unreinforced masonry parapets. Parapets constructed of unreinforced masonry in buildings assigned to Seismic Design Category C, D, E or F shall have bracing installed as needed to resist the reduced *International Building Code*-level seismic forces in accordance with Section 303.3, unless an evaluation demonstrates compliance of such items. Use of reduced seismic forces shall be permitted.

[BS] 906.7 Anchorage of unreinforced masonry partitions. Where the building is assigned to Seismic Design Category C, D, E or F, unreinforced masonry partitions and nonstructural walls within the *work area* and adjacent to egress paths from the *work area* shall be anchored, removed, or altered to resist out-of-plane seismic forces, unless an evaluation demonstrates compliance of such items. Use of reduced seismic forces shall be permitted.

SECTION 907 ENERGY CONSERVATION

907.1 Minimum requirements. Level 3 *alterations* to *existing buildings* or structures are permitted without requiring the entire building or structure to comply with the energy requirements of the *International Energy Conservation Code* or *International Residential Code*. The *alterations* shall conform to the energy requirements of the *International Energy Conservation Code* or *International Residential Code* as they relate to new construction only.

CHAPTER 10

CHANGE OF OCCUPANCY

User note:

About this chapter: The purpose of this chapter is to provide regulations for the circumstances where an existing building is subject to a change of occupancy or a change of occupancy classification. A change of occupancy is not to be confused with a change of occupancy classification. The International Building Code® defines different occupancy classifications in Chapter 3 and special occupancy requirements in Chapter 4. Within specific occupancy classifications there can be many different types of actual activities that can take place. For instance, a Group A-3 occupancy classification deals with a wide variation of different types of activities, including bowling alleys and courtrooms, indoor tennis courts and dance halls. When a facility changes use from, for example, a bowling alley to a dance hall, the occupancy classification remains A-3, but the different uses could lead to drastically different code requirements. Therefore, this chapter deals with the special circumstances that are associated with a change in the use of a building within the same occupancy classification as well as a change of occupancy classification.

SECTION 1001 GENERAL

1001.1 Scope. The provisions of this chapter shall apply where a *change of occupancy* occurs, as defined in Section 202.

1001.2 Certificate of occupancy. A *change of occupancy* or a *change of occupancy* within a space where there is a different fire protection system threshold requirement in Chapter 9 of the *International Building Code* shall not be made to any structure without the approval of the *code official*. A certificate of occupancy shall be issued where it has been determined that the requirements for the *change of occupancy* have been met.

1001.2.1 Change of use. Any work undertaken in connection with a change in use that does not involve a change of occupancy classification or a change to another group within an occupancy classification shall conform to the applicable requirements for the work as classified in Chapter 5 and to the requirements of Sections 1002 through 1010.

Exception: As modified in Section 1204 for *historic buildings*.

1001.2.2 Change of occupancy classification or group. Where the occupancy classification of a building changes, the provisions of Sections 1002 through 1011 shall apply. This includes a change of occupancy classification and a change to another group within an occupancy classification.

1001.2.2.1 Partial change of occupancy. Where the occupancy classification or group of a portion of an *existing building* is changed, Section 1011 shall apply.

1001.3 Certificate of occupancy required. A certificate of occupancy shall be issued where a *change of occupancy* occurs that results in a different occupancy classification as determined by the *International Building Code*.

SECTION 1002 SPECIAL USE AND OCCUPANCY

1002.1 Compliance with the building code. Where the character or use of an *existing building* or part of an *existing building* is changed to one of the following special use or occupancy categories as defined in the *International Building Code*, the building shall comply with all of the applicable requirements of the *International Building Code*:

1. Covered and open mall buildings.
2. Atriums.
3. Motor vehicle-related occupancies.
4. Aircraft-related occupancies.
5. Motion picture projection rooms.
6. Stages and platforms.
7. Special amusement buildings.
8. Incidental use areas.
9. Hazardous materials.
10. Ambulatory care facilities.
11. Group I-2 occupancies.

1002.2 Underground buildings. An underground building in which there is a change of use shall comply with the requirements of the *International Building Code* applicable to underground structures.

SECTION 1003 BUILDING ELEMENTS AND MATERIALS

1003.1 General. Building elements and materials in portions of buildings undergoing a change of occupancy classification shall comply with Section 1011.

SECTION 1004 FIRE PROTECTION

1004.1 General. Fire protection requirements of Section 1011 shall apply where a building or portions thereof undergo a *change of occupancy* classification or where there is a change of occupancy within a space where there is a different fire protection system threshold requirement in Chapter 9 of the *International Building Code*.

SECTION 1005 MEANS OF EGRESS

1005.1 General. Means of egress in portions of buildings undergoing a change of occupancy classification shall comply with Section 1011.

SECTION 1006 STRUCTURAL

[BS] 1006.1 Live loads. Structural elements carrying tributary live loads from an area with a *change of occupancy* shall satisfy the requirements of Section 1607 of the *International Building Code*. Design live loads for areas of new occupancy shall be based on Section 1607 of the *International Building Code*. Design live loads for other areas shall be permitted to use previously *approved* design live loads.

Exception: Structural elements whose demand-capacity ratio considering the *change of occupancy* is not more than 5 percent greater than the demand-capacity ratio based on previously *approved* live loads.

[BS] 1006.2 Snow and wind loads. Where a *change of occupancy* results in a structure being assigned to a higher *risk category*, the structure shall satisfy the requirements of Sections 1608 and 1609 of the *International Building Code* for the new risk category.

Exception: Where the area of the new occupancy is less than 10 percent of the building area. The cumulative effect of occupancy changes over time shall be considered.

[BS] 1006.3 Seismic loads. Where a *change of occupancy* results in a building being assigned to a higher *risk category*, the building shall satisfy the requirements of Section 1613 of the *International Building Code* for the new *risk category* using full seismic forces.

Exceptions:

1. Where a change of use results in a building being reclassified from *Risk Category* I or II to *Risk Category* III and the seismic coefficient, S_{DS} , is less than 0.33.
2. Where the area of the new occupancy is less than 10 percent of the building area and the new occupancy is not assigned to *Risk Category* IV. The cumulative effect of occupancy changes over time shall be considered.
3. Unreinforced masonry bearing wall buildings assigned to *Risk Category* III and to Seismic Design Category A or B shall be permitted to use Appendix Chapter A1 of this code.

[BS] 1006.4 Access to Risk Category IV. Any structure that provides operational access to an adjacent structure assigned to *Risk Category* IV as the result of a change of occupancy shall itself satisfy the requirements of Sections 1608, 1609 and 1613 of the *International Building Code*. For compliance with Section 1613, the full seismic forces shall be used. Where operational access to *Risk Category* IV is less than 10 feet (3048 mm) from either an interior lot line or from another structure, access protection from potential falling debris shall be provided.

SECTION 1007 ELECTRICAL

1007.1 Special occupancies. Where the occupancy of an *existing building* or part of an *existing building* is changed to one of the following special occupancies as described in NFPA 70, the electrical wiring and equipment of the building or portion thereof that contains the proposed occupancy shall comply with the applicable requirements of NFPA 70 whether or not a *change of occupancy* group is involved:

1. Hazardous locations.
2. Commercial garages, *repair* and storage.
3. Aircraft hangars.
4. Gasoline dispensing and service stations.
5. Bulk storage plants.
6. Spray application, dipping and coating processes.
7. Health care facilities.
8. Places of assembly.
9. Theaters, audience areas of motion picture and television studios, and similar locations.
10. Motion picture and television studios and similar locations.
11. Motion picture projectors.
12. Agricultural buildings.

1007.2 Unsafe conditions. Where the occupancy of an *existing building* or part of an *existing building* is changed, all unsafe conditions shall be corrected without requiring that all parts of the electrical system comply with NFPA 70.

1007.3 Service upgrade. Where the occupancy of an *existing building* or part of an *existing building* is changed, electrical service shall be upgraded to meet the requirements of NFPA 70 for the new occupancy.

1007.4 Number of electrical outlets. Where the occupancy of an *existing building* or part of an *existing building* is changed, the number of electrical outlets shall comply with NFPA 70 for the new occupancy.

SECTION 1008 MECHANICAL

1008.1 Mechanical requirements. Where the occupancy of an *existing building* or part of an *existing building* is changed such that the new occupancy is subject to different kitchen

exhaust requirements or to increased mechanical ventilation requirements in accordance with the *International Mechanical Code*, the new occupancy shall comply with the respective *International Mechanical Code* provisions.

SECTION 1009 PLUMBING

1009.1 Increased demand. Where the occupancy of an *existing building* or part of an *existing building* is changed such that the new occupancy is subject to increased or different plumbing fixture requirements or to increased water supply requirements in accordance with the *International Plumbing Code*, the new occupancy shall comply with the intent of the respective *International Plumbing Code* provisions.

1009.2 Food-handling occupancies. If the new occupancy is a food-handling establishment, all existing sanitary waste lines above the food or drink preparation or storage areas shall be panned or otherwise protected to prevent leaking pipes or condensation on pipes from contaminating food or drink. New drainage lines shall not be installed above such areas and shall be protected in accordance with the *International Plumbing Code*.

1009.3 Interceptor required. If the new occupancy will produce grease or oil-laden wastes, interceptors shall be provided as required in the *International Plumbing Code*.

1009.4 Chemical wastes. If the new occupancy will produce chemical wastes, the following shall apply:

1. If the existing piping is not compatible with the chemical waste, the waste shall be neutralized prior to entering the drainage system, or the piping shall be changed to a compatible material.
2. Chemical waste shall not discharge to a public sewer system without the approval of the sewage authority.

1009.5 Group I-2. If the occupancy group is changed to Group I-2, the plumbing system shall comply with the applicable requirements of the *International Plumbing Code*.

SECTION 1010 OTHER REQUIREMENTS

1010.1 Light and ventilation. Light and ventilation shall comply with the requirements of the *International Building Code* for the new occupancy.

SECTION 1011 CHANGE OF OCCUPANCY CLASSIFICATION

1011.1 General. The provisions of this section shall apply to buildings or portions thereof undergoing a change of occupancy classification. This includes a change of occupancy classification within a group as well as a change of occupancy classification from one group to a different group or where there is a *change of occupancy* within a space where there is a different fire protection system threshold requirement in Chapter 9 of the *International Building Code*. Such buildings shall also comply with Sections 1002 through 1010 of this code. The application of requirements for the *change*

of occupancy shall be as set forth in Sections 1011.1.1 through 1011.1.4. A *change of occupancy*, as defined in Section 202, without a corresponding change of occupancy classification shall comply with Section 1001.2.

1011.1.1 Compliance with Chapter 9. The requirements of Chapter 9 shall be applicable throughout the building for the new occupancy classification based on the separation conditions set forth in Sections 1011.1.1.1 and 1011.1.1.2.

1011.1.1.1 Change of occupancy classification without separation. Where a portion of an *existing building* is changed to a new occupancy classification or where there is a *change of occupancy* within a space where there is a different fire protection system threshold requirement in Chapter 9 of the *International Building Code*, and that portion is not separated from the remainder of the building with fire barriers having a fire-resistance rating as required in the *International Building Code* for the separate occupancy, the entire building shall comply with all of the requirements of Chapter 9 of this code applied throughout the building for the most restrictive occupancy classification in the building and with the requirements of this chapter.

1011.1.1.2 Change of occupancy classification with separation. Where a portion of an *existing building* is changed to a new occupancy classification or where there is a *change of occupancy* within a space where there is a different fire protection system threshold requirement in Chapter 9 of the *International Building Code*, and that portion is separated from the remainder of the building with fire barriers having a fire-resistance rating as required in the *International Building Code* for the separate occupancy, that portion shall comply with all of the requirements of Chapter 9 of this code for the new occupancy classification and with the requirements of this chapter.

1011.1.2 Fire protection and interior finish. The provisions of Sections 1011.2 and 1011.3 for fire protection and interior finish, respectively, shall apply to all buildings undergoing a change of occupancy classification.

1011.1.3 Change of occupancy classification based on hazard category. The relative degree of hazard between different occupancy classifications shall be determined in accordance with the categories specified in Tables 1011.4, 1011.5 and 1011.6. Such a determination shall be the basis for the application of Sections 1011.4 through 1011.7.

1011.2 Fire protection systems. Fire protection systems shall be provided in accordance with Sections 1011.2.1 and 1011.2.2.

1011.2.1 Fire sprinkler system. Where a change in occupancy classification occurs or where there is a *change of occupancy* within a space where there is a different fire protection system threshold requirement in Chapter 9 of the *International Building Code* that requires an automatic fire sprinkler system to be provided based on the new occupancy in accordance with Chapter 9 of the *International Building Code*, such system shall be provided

CHANGE OF OCCUPANCY

throughout the area where the *change of occupancy* occurs.

1011.2.2 Fire alarm and detection system. Where a change in occupancy classification occurs or where there is a *change of occupancy* within a space where there is a different fire protection system threshold requirement in Chapter 9 of the *International Building Code* that requires a fire alarm and detection system to be provided based on the new occupancy in accordance with Chapter 9 of the *International Building Code*, such system shall be provided throughout the area where the *change of occupancy* occurs. Existing alarm notification appliances shall be automatically activated throughout the building. Where the building is not equipped with a fire alarm system, alarm notification appliances shall be provided throughout the area where the *change of occupancy* occurs in accordance with Section 907 of the *International Building Code* as required for new construction.

1011.3 Interior finish. In areas of the building undergoing the change of occupancy classification, the interior finish of walls and ceilings shall comply with the requirements of the *International Building Code* for the new occupancy classification.

1011.4 Means of egress, general. Hazard categories in regard to life safety and means of egress shall be in accordance with Table 1011.4.

**TABLE 1011.4
MEANS OF EGRESS HAZARD CATEGORIES**

RELATIVE HAZARD	OCCUPANCY CLASSIFICATIONS
1 (Highest Hazard)	H
2	I-2; I-3; I-4
3	A; E; I-1; M; R-1; R-2; R-4, Condition 2
4	B; F-1; R-3; R-4, Condition 1; S-1
5 (Lowest Hazard)	F-2; S-2; U

1011.4.1 Means of egress for change to a higher-hazard category. Where a change of occupancy classification is made to a higher-hazard category (lower number) as shown in Table 1011.4, the means of egress shall comply with the requirements of Chapter 10 of the *International Building Code*.

Exceptions:

1. Stairways shall be enclosed in compliance with the applicable provisions of Section 903.1.
2. Existing stairways including handrails and guards complying with the requirements of Chapter 9 shall be permitted for continued use subject to approval of the *code official*.
3. Any stairway replacing an existing stairway within a space where the pitch or slope cannot be reduced because of existing construction shall not be required to comply with the maximum riser height and minimum tread depth requirements.
4. Existing corridor walls constructed on both sides of wood lath and plaster in good condition or 1/2-

inch-thick (12.7 mm) gypsum wallboard shall be permitted. Such walls shall either terminate at the underside of a ceiling of equivalent construction or extend to the underside of the floor or roof next above.

5. Existing corridor doorways, transoms and other corridor openings shall comply with the requirements in Sections 805.5.1, 805.5.2 and 805.5.3.
6. Existing dead-end corridors shall comply with the requirements in Section 805.6.
7. An existing operable window with clear opening area not less than 4 square feet (0.38 m²) and minimum opening height and width of 22 inches (559 mm) and 20 inches (508 mm), respectively, shall be accepted as an emergency escape and rescue opening.

1011.4.2 Means of egress for change of use to an equal or lower-hazard category. Where a change of occupancy classification is made to an equal or lesser-hazard category (higher number) as shown in Table 1011.4, existing elements of the means of egress shall comply with the requirements of Section 905 for the new occupancy classification. Newly constructed or configured means of egress shall comply with the requirements of Chapter 10 of the *International Building Code*.

Exception: Any stairway replacing an existing stairway within a space where the pitch or slope cannot be reduced because of existing construction shall not be required to comply with the maximum riser height and minimum tread depth requirements.

1011.4.3 Egress capacity. Egress capacity shall meet or exceed the occupant load as specified in the *International Building Code* for the new occupancy.

1011.4.4 Handrails. Existing stairways shall comply with the handrail requirements of Section 805.9 in the area of the *change of occupancy* classification.

1011.4.5 Guards. Existing guards shall comply with the requirements in Section 805.11 in the area of the *change of occupancy* classification.

1011.5 Heights and areas. Hazard categories in regard to height and area shall be in accordance with Table 1011.5.

**TABLE 1011.5
HEIGHTS AND AREAS HAZARD CATEGORIES**

RELATIVE HAZARD	OCCUPANCY CLASSIFICATIONS
1 (Highest Hazard)	H
2	A-1; A-2; A-3; A-4; I; R-1; R-2; R-4, Condition 2
3	E; F-1; S-1; M
4 (Lowest Hazard)	B; F-2; S-2; A-5; R-3; R-4, Condition 1; U

1011.5.1 Height and area for change to a higher-hazard category. Where a change of occupancy classification is made to a higher-hazard category as shown in Table 1011.5, heights and areas of buildings and structures shall

comply with the requirements of Chapter 5 of the *International Building Code* for the new occupancy classification.

Exception: For high-rise buildings constructed in compliance with a previously issued permit, the type of construction reduction specified in Section 403.2.1 of the *International Building Code* is permitted. This shall include the reduction for columns. The high-rise building is required to be equipped throughout with an automatic sprinkler system in accordance with Section 903.3.1.1 of the *International Building Code*.

1011.5.1.1 Fire wall alternative. In other than Groups H, F-1 and S-1, fire barriers and horizontal assemblies constructed in accordance with Sections 707 and 711, respectively, of the *International Building Code* shall be permitted to be used in lieu of fire walls to subdivide the building into separate buildings for the purpose of complying with the area limitations required for the new occupancy where all of the following conditions are met:

1. The buildings are protected throughout with an automatic sprinkler system in accordance with Section 903.3.1.1 of the *International Fire Code*.
2. The maximum allowable area between fire barriers, horizontal assemblies, or any combination thereof shall not exceed the maximum allowable area determined in accordance with Chapter 5 of the *International Building Code* without an increase allowed for an automatic sprinkler system in accordance with Section 506 of the *International Building Code*.
3. The fire-resistance rating of the fire barriers and horizontal assemblies shall be not less than that specified for fire walls in Table 706.4 of the *International Building Code*.

Exception: Where horizontal assemblies are used to limit the maximum allowable area, the required fire-resistance rating of the horizontal assemblies shall be permitted to be reduced by 1 hour provided that the height and number of stories increases allowed for an automatic sprinkler system by Section 504 of the *International Building Code* are not used for the buildings.

1011.5.2 Height and area for change to an equal or lesser-hazard category. Where a change of occupancy classification is made to an equal or lesser-hazard category as shown in Table 1011.5, the height and area of the *existing building* shall be deemed acceptable.

1011.5.3 Fire barriers. Where a change of occupancy classification is made to a higher-hazard category as shown in Table 1011.5, fire barriers in separated mixed use buildings shall comply with the fire-resistance requirements of the *International Building Code*.

Exception: Where the fire barriers are required to have a 1-hour fire-resistance rating, existing wood lath and plaster in good condition or existing $\frac{1}{2}$ -inch-thick (12.7 mm) gypsum wallboard shall be permitted.

1011.6 Exterior wall fire-resistance ratings. Hazard categories in regard to fire-resistance ratings of exterior walls shall be in accordance with Table 1011.6.

**TABLE 1011.6
EXPOSURE OF EXTERIOR WALLS HAZARD CATEGORIES**

RELATIVE HAZARD	OCCUPANCY CLASSIFICATION
1 (Highest Hazard)	H
2	F-1; M; S-1
3	A; B; E; I; R
4 (Lowest Hazard)	F-2; S-2; U

1011.6.1 Exterior wall rating for change of occupancy classification to a higher-hazard category. Where a change of occupancy classification is made to a higher-hazard category as shown in Table 1011.6, exterior walls shall have fire resistance and exterior opening protectives as required by the *International Building Code*.

Exception: A 2-hour fire-resistance rating shall be allowed where the building does not exceed three stories in height and is classified as one of the following groups: A-2 and A-3 with an occupant load of less than 300, B, F, M or S.

1011.6.2 Exterior wall rating for change of occupancy classification to an equal or lesser-hazard category. Where a change of occupancy classification is made to an equal or lesser-hazard category as shown in Table 1011.6, existing exterior walls, including openings, shall be accepted.

1011.6.3 Opening protectives. Openings in exterior walls shall be protected as required by the *International Building Code*. Where openings in the exterior walls are required to be protected because of their distance from the lot line, the sum of the area of such openings shall not exceed 50 percent of the total area of the wall in each story.

Exceptions:

1. Where the *International Building Code* permits openings in excess of 50 percent.
2. Protected openings shall not be required in buildings of Group R occupancy that do not exceed three stories in height and that are located not less than 3 feet (914 mm) from the lot line.
3. Exterior opening protectives are not required where an automatic sprinkler system has been installed throughout.
4. Exterior opening protectives are not required where the *change of occupancy* group is to an equal or lower hazard classification in accordance with Table 1011.6.

1011.7 Enclosure of vertical shafts. Enclosure of vertical shafts shall be in accordance with Sections 1011.7.1 through 1011.7.4.

1011.7.1 Minimum requirements. Vertical shafts shall be designed to meet the *International Building Code*

CHAPTER 11

ADDITIONS

User note:

About this chapter: Chapter 11 provides the requirements for additions, which correlate to the code requirements for new construction. There are, however, some exceptions that are specifically stated within this chapter. An “Addition” is defined in Chapter 2 as “an extension or increase in the floor area, number of stories or height of a building or structure.” Chapter 11 contains the minimum requirements for an addition that is not separated from the existing building by a fire wall.

SECTION 1101 GENERAL

1101.1 Scope. An *addition* to a building or structure shall comply with the *International Codes* as adopted for new construction without requiring the *existing building* or structure to comply with any requirements of those codes or of these provisions, except as required by this chapter. Where an *addition* impacts the *existing building* or structure, that portion shall comply with this code.

1101.2 Creation or extension of nonconformity. An *addition* shall not create or extend any nonconformity in the *existing building* to which the *addition* is being made with regard to accessibility, structural strength, fire safety, means of egress, or the capacity of mechanical, plumbing, or electrical systems.

1101.3 Other work. Any *repair* or *alteration* work within an *existing building* to which an *addition* is being made shall comply with the applicable requirements for the work as classified in Chapter 6.

SECTION 1102 HEIGHTS AND AREAS

1102.1 Height limitations. An *addition* shall not increase the height of an *existing building* beyond that permitted under the applicable provisions of Chapter 5 of the *International Building Code* for new buildings.

1102.2 Area limitations. An *addition* shall not increase the area of an *existing building* beyond that permitted under the applicable provisions of Chapter 6 of the *International Building Code* for new buildings unless fire separation as required by the *International Building Code* is provided.

Exception: In-filling of floor openings and nonoccupiable appendages such as elevator and exit stairway shafts shall be permitted beyond that permitted by the *International Building Code*.

1102.3 Fire protection systems. Existing fire areas increased by the *addition* shall comply with Chapter 9 of the *International Building Code*.

SECTION 1103 STRUCTURAL

[BS] 1103.1 Additional gravity loads. Any existing gravity load-carrying structural element for which an *addition* and its related *alterations* cause an increase in design dead, live or

snow load, including snow drift effects, of more than 5 percent shall be replaced or altered as needed to carry the gravity loads required by the *International Building Code* for new structures. Any existing gravity load-carrying structural element whose gravity load-carrying capacity is decreased as part of the *addition* and its related *alterations* shall be considered to be an altered element subject to the requirements of Section 806.2. Any existing element that will form part of the lateral load path for any part of the *addition* shall be considered to be an existing lateral load-carrying structural element subject to the requirements of Section 1103.3.

Exception: Buildings of Group R occupancy with not more than five dwelling units or sleeping units used solely for residential purposes where the *existing building* and the *addition* together comply with the conventional light-frame construction methods of the *International Building Code* or the provisions of the *International Residential Code*.

[BS] 1103.2 Lateral force-resisting system. Where the *addition* is structurally independent of the *existing structure*, existing lateral load-carrying structural elements shall be permitted to remain unaltered. Where the *addition* is not structurally independent of the *existing structure*, the *existing structure* and its *addition* acting together as a single structure shall meet the requirements of Sections 1609 and 1613 of the *International Building Code* using full seismic forces.

Exceptions:

1. Buildings of Group R occupancy with not more than five dwelling or sleeping units used solely for residential purposes where the *existing building* and the *addition* comply with the conventional light-frame construction methods of the *International Building Code* or the provisions of the *International Residential Code*.
2. Any existing lateral load-carrying structural element whose demand-capacity ratio with the *addition* considered is not more than 10 percent greater than its demand-capacity ratio with the *addition* ignored shall be permitted to remain unaltered. For purposes of calculating demand-capacity ratios, the demand shall consider applicable load combinations with design lateral loads or forces in accordance with Sections 1609 and 1613 of the *International Building Code*. For purposes of this exception, comparisons of demand-capacity ratios and calculation of design lateral loads, forces and capacities shall

ADDITIONS

account for the cumulative effects of *additions* and *alterations* since original construction.

[BS] 1103.3 Flood hazard areas. *Additions* and *foundations* in *flood hazard areas* shall comply with the following requirements:

1. For horizontal *additions* that are structurally interconnected to the *existing building*:
 - 1.1. If the *addition* and all other proposed work, when combined, constitute *substantial improvement*, the *existing building* and the *addition* shall comply with Section 1612 of the *International Building Code*, or Section R322 of the *International Residential Code*, as applicable.
 - 1.2. If the *addition* constitutes *substantial improvement*, the *existing building* and the *addition* shall comply with Section 1612 of the *International Building Code*, or Section R322 of the *International Residential Code*, as applicable.
2. For horizontal *additions* that are not structurally interconnected to the *existing building*:
 - 2.1. The *addition* shall comply with Section 1612 of the *International Building Code*, or Section R322 of the *International Residential Code*, as applicable.
 - 2.2. If the *addition* and all other proposed work, when combined, constitute *substantial improvement*, the *existing building* and the *addition* shall comply with Section 1612 of the *International Building Code*, or Section R322 of the *International Residential Code*, as applicable.
3. For vertical *additions* and all other proposed work that, when combined, constitute *substantial improvement*, the *existing building* shall comply with Section 1612 of the *International Building Code*, or Section R322 of the *International Residential Code*, as applicable.
4. For a raised or extended foundation, if the foundation work and all other proposed work, when combined, constitute *substantial improvement*, the *existing building* shall comply with Section 1612 of the *International Building Code*, or Section R322 of the *International Residential Code*, as applicable.
5. For a new foundation or replacement foundation, the foundation shall comply with Section 1612 of the *International Building Code* or Section R322 of the *International Residential Code*, as applicable.

SECTION 1104 SMOKE ALARMS IN OCCUPANCY GROUPS R AND I-1

1104.1 Smoke alarms in existing portions of a building. Where an *addition* is made to a building or structure of a Group R or I-1 occupancy, the *existing building* shall be provided with smoke alarms as required by Section 1103.8 of the *International Fire Code* or Section R314 of the *International Residential Code* as applicable.

SECTION 1105 CARBON MONOXIDE ALARMS IN GROUPS I-1, I-2, I-4 AND R

1105.1 Carbon monoxide alarms in existing portions of a building. Where an *addition* is made to a building or structure of a Group I-1, I-2, I-4 or R occupancy, the *existing building* shall be equipped with carbon monoxide alarms in accordance with Section 1103.9 of the *International Fire Code* or Section R315 of the *International Residential Code*, as applicable.

SECTION 1106 STORM SHELTERS

1106.1 Addition to a Group E occupancy. Where an *addition* is added to an existing Group E occupancy located in an area where the shelter design wind speed for tornados is 250 mph in accordance with Figure 304.2(1) of ICC 500 and the occupant load in the *addition* is 50 or more, the *addition* shall have a storm shelter constructed in accordance with ICC 500.

Exceptions:

1. Group E day care facilities.
2. Group E occupancies accessory to places of religious worship.
3. *Additions* meeting the requirements for shelter design in ICC 500.

1106.1.1 Required occupant capacity. The required occupant capacity of the storm shelter shall include all buildings on the site, and shall be the greater of the following:

1. The total occupant load of the classrooms, vocational rooms and offices in the Group E occupancy.
2. The occupant load of any indoor assembly space that is associated with the Group E occupancy.

Exceptions:

1. Where an *addition* is being added on an existing Group E site, and where the *addition* is not of sufficient size to accommodate the required occupant capacity of the storm shelter for all of the buildings on-site, the storm shelter shall at a minimum accommodate the required capacity for the *addition*.
2. Where *approved* by the code official, the required occupant capacity of the shelter shall be permitted to be reduced by the occupant capacity of any existing storm shelters on the site.

1106.1.2 Location. Storm shelters shall be located within the buildings they serve, or shall be located where the maximum distance of travel from not fewer than one exterior door of each building to a door of the shelter serving that building does not exceed 1,000 feet (305 m).

SECTION 1107 ENERGY CONSERVATION

1107.1 Minimum requirements. *Additions* to *existing buildings* shall conform to the energy requirements of the *International Energy Conservation Code* or *International Residential Code* as they relate to new construction.

CHAPTER 12

HISTORIC BUILDINGS

User note:

About this chapter: Chapter 12 provides some exceptions from code requirements when the building in question has historic value. The most important criterion for application of this chapter is that the building must be essentially accredited as being of historic significance by a state or local authority after careful review of the historical value of the building. Most, if not all, states have such authorities, as do many local jurisdictions. The agencies with such authority can be located at the state or local government level or through the local chapter of the American Institute of Architects (AIA). Other considerations include the structural condition of the building (i.e., is the building structurally sound), its proposed use, its impact on life safety and how the intent of the code, if not the letter, will be achieved.

SECTION 1201 GENERAL

1201.1 Scope. This chapter is intended to provide means for the preservation of *historic buildings*. *Historic buildings* shall comply with the provisions of this chapter relating to their *repair, alteration, relocation and change of occupancy*.

[BS] 1201.2 Report. A *historic building* undergoing *alteration* or *change of occupancy* shall be investigated and evaluated. If it is intended that the building meet the requirements of this chapter, a written report shall be prepared and filed with the *code official* by a registered design professional where such a report is necessary in the opinion of the *code official*. Such report shall be in accordance with Chapter 1 and shall identify each required safety feature that is in compliance with this chapter and where compliance with other chapters of these provisions would be damaging to the contributing historic features. For buildings assigned to Seismic Design Category D, E or F, a structural evaluation describing, at a minimum, the vertical and horizontal elements of the lateral force-resisting system and any strengths or weaknesses therein shall be prepared. Additionally, the report shall describe each feature that is not in compliance with these provisions and shall demonstrate how the intent of these provisions is complied with in providing an equivalent level of safety.

1201.3 Special occupancy exceptions—museums. Where a building in Group R-3 is used for Group A, B or M purposes such as museum tours, exhibits, and other public assembly activities, or for museums less than 3,000 square feet (279 m²), the *code official* may determine that the occupancy is Group B where life safety conditions can be demonstrated in accordance with Section 1201.2. Adequate means of egress in such buildings, which may include a means of maintaining doors in an open position to permit egress, a limit on building occupancy to an occupant load permitted by the means of egress capacity, a limit on occupancy of certain areas or floors, or supervision by a person knowledgeable in the emergency exiting procedures, shall be provided.

[BS] 1201.4 Flood hazard areas. In *flood hazard areas*, if all proposed work, including *repairs*, work required because of a *change of occupancy*, and *alterations*, constitutes *substantial improvement*, then the *existing building* shall comply with

Section 1612 of the *International Building Code*, or Section R322 of the *International Residential Code*, as applicable.

Exception: If a *historic building* will continue to be a *historic building* after the proposed work is completed, then the proposed work is not considered a *substantial improvement*. For the purposes of this exception, a *historic building* is any of the following:

1. Listed or preliminarily determined to be eligible for listing in the National Register of Historic Places.
2. Determined by the Secretary of the U.S. Department of Interior to contribute to the historical significance of a registered historic district or a district preliminarily determined to qualify as a historic district.
3. Designated as historic under a state or local historic preservation program that is approved by the Department of Interior.

1201.5 Unsafe conditions. Conditions determined by the *code official* to be *unsafe* shall be remedied. Work shall not be required beyond what is required to remedy the *unsafe* conditions. **

SECTION 1202 REPAIRS

1202.1 General. Repairs to any portion of a *historic building* or structure shall be permitted with original or like materials and original methods of construction, subject to the provisions of this chapter. Hazardous materials, such as asbestos and lead-based paint, shall not be used where the code for new construction would not permit their use in buildings of similar occupancy, purpose and location.

1202.2 Replacement. Replacement of existing or missing features using original materials shall be permitted. Partial replacement for *repairs* that match the original in configuration, height, and size shall be permitted. *

Replacement glazing in hazardous locations shall comply with the safety glazing requirements of Chapter 24 of the *International Building Code*.

Exception: Glass block walls, louvered windows, and jalousies repaired with like materials. *

**SECTION 1203
FIRE SAFETY**

1203.1 Scope. *Historic buildings* undergoing alterations, changes of occupancy, or that are moved shall comply with Section 1203.

1203.2 General. Every *historic building* that does not conform to the construction requirements specified in this code for the occupancy or use and that constitutes a distinct fire hazard as defined herein shall be provided with an *approved* automatic fire-extinguishing system as determined appropriate by the *code official*. However, an automatic fire-extinguishing system shall not be used to substitute for, or act as an alternative to, the required number of exits from any *facility*.

1203.3 Means of egress. Existing door openings and corridor and stairway widths less than those specified elsewhere in this code may be *approved*, provided that, in the opinion of the *code official*, there is sufficient width and height for a person to pass through the opening or traverse the means of egress. Where *approved* by the *code official*, the front or main exit doors need not swing in the direction of the path of exit travel, provided that other *approved* means of egress having sufficient capacity to serve the total occupant load are provided.

1203.4 Transoms. In fully sprinklered buildings of Group R-1, R-2 or R-3 occupancy, existing transoms in corridors and other fire-resistance-rated walls may be maintained if fixed in the closed position. A sprinkler shall be installed on each side of the transom.

1203.5 Interior finishes. The existing interior finishes shall be accepted where it is demonstrated that they are the historic finishes.

1203.6 Stairway enclosure. In buildings of three stories or less, exit enclosure construction shall limit the spread of smoke by the use of tight-fitting doors and solid elements. Such elements are not required to have a fire-resistance rating.

1203.7 One-hour fire-resistant assemblies. Where 1-hour fire-resistance-rated construction is required by these provisions, it need not be provided, regardless of construction or occupancy, where the existing wall and ceiling finish is wood or metal lath and plaster.

1203.8 Glazing in fire-resistance-rated systems. Historic glazing materials are permitted in interior walls required to have a 1-hour fire-resistance rating where the opening is provided with *approved* smoke seals and the area affected is provided with an automatic sprinkler system.

1203.9 Stairway railings. Grand stairways shall be accepted without complying with the handrail and guard requirements. Existing handrails and guards at all stairways shall be permitted to remain, provided they are not structurally *dangerous*.

1203.10 Guards. Guards shall comply with Sections 1203.10.1 and 1203.10.2.

1203.10.1 Height. Existing guards shall comply with the requirements of Section 704.

1203.10.2 Guard openings. The spacing between existing intermediate railings or openings in existing ornamental

patterns shall be accepted. Missing elements or members of a guard may be replaced in a manner that will preserve the historic appearance of the building or structure.

1203.11 Exit signs. Where exit sign or egress path marking location would damage the historic character of the building, alternative exit signs are permitted with approval of the *code official*. Alternative signs shall identify the exits and egress path.

1203.12 Automatic fire-extinguishing systems. Every *historic building* that cannot be made to conform to the construction requirements specified in the *International Building Code* for the occupancy or use and that constitutes a distinct fire hazard shall be deemed to be in compliance if provided with an *approved* automatic fire-extinguishing system.

Exception: Where the *code official* approves an alternative life-safety system.

**SECTION 1204
CHANGE OF OCCUPANCY**

1204.1 General. *Historic buildings* undergoing a change of occupancy shall comply with the applicable provisions of Chapter 10, except as specifically permitted in this chapter. Where Chapter 10 requires compliance with specific requirements of Chapter 7, Chapter 8 or Chapter 9 and where those requirements are subject to the exceptions in Section 1202, the same exceptions shall apply to this section.

1204.2 Building area. The allowable floor area for *historic buildings* undergoing a change of occupancy shall be permitted to exceed by 20 percent the allowable areas specified in Chapter 5 of the *International Building Code*.

1204.3 Location on property. Historic structures undergoing a change of use to a higher-hazard category in accordance with Section 1011.6 may use alternative methods to comply with the fire-resistance and exterior opening protective requirements. Such alternatives shall comply with Section 1201.2.

1204.4 Occupancy separation. Required occupancy separations of 1 hour may be omitted where the building is provided with an *approved* automatic sprinkler system throughout.

1204.5 Roof covering. Regardless of occupancy or use group, roof-covering materials not less than Class C, where tested in accordance with ASTM E108 or UL 790, shall be permitted where a fire-retardant roof covering is required.

1204.6 Means of egress. Existing door openings and corridor and stairway widths less than those that would be acceptable for nonhistoric buildings under these provisions shall be *approved*, provided that, in the opinion of the *code official*, there is sufficient width and height for a person to pass through the opening or traverse the exit and that the capacity of the exit system is adequate for the occupant load, or where other operational controls to limit occupancy are *approved* by the *code official*.

1204.7 Door swing. Where *approved* by the *code official*, existing front doors need not swing in the direction of exit travel, provided that other *approved* exits having sufficient capacity to serve the total occupant load are provided.

1204.8 Transoms. In corridor walls required by these provisions to be fire-resistance rated, existing transoms may be maintained if fixed in the closed position, and fixed wired glass set in a steel frame or other *approved* glazing shall be installed on one side of the transom.

Exception: Transoms conforming to Section 1203.4 shall be accepted.

1204.9 Finishes. Where interior finish materials are required to have a flame spread index of Class C or better, when tested in accordance with ASTM E84 or UL 723, existing nonconforming materials shall be surfaced with *approved* fire-retardant paint or finish.

Exception: Existing nonconforming materials need not be surfaced with an *approved* fire-retardant paint or finish where the building is equipped throughout with an automatic sprinkler system installed in accordance with the *International Building Code* and the nonconforming materials can be substantiated as being historic in character.

1204.10 One-hour fire-resistant assemblies. Where 1-hour fire-resistance-rated construction is required by these provisions, it need not be provided, regardless of construction or occupancy, where the existing wall and ceiling finish is wood lath and plaster.

1204.11 Stairways and guards. Existing stairways shall comply with the requirements of these provisions. The *code official* shall grant alternatives for stairways and guards if alternative stairways are found to be acceptable or are judged to meet the intent of these provisions. Existing stairways shall comply with Section 1203.

Exception: For buildings less than 3,000 square feet (279 m²), existing conditions are permitted to remain at all stairways and guards.

1204.12 Exit signs. The *code official* may accept alternative exit sign locations where the location of such signs would damage the historic character of the building or structure. Such signs shall identify the exits and exit path.

[BS] 1204.13 Exit stair live load. Existing historic stairways in buildings changed to a Group R-1 or R-2 occupancy shall be accepted where it can be shown that the stairway can support a 75-pounds-per-square-foot (366 kg/m²) live load.

1204.14 Natural light. Where it is determined by the *code official* that compliance with the natural light requirements of Section 1010.1 will lead to loss of historic character or historic materials in the building, the existing level of natural lighting shall be considered to be acceptable.

SECTION 1205 STRUCTURAL

[BS] 1205.1 General. *Historic buildings* shall comply with the applicable structural provisions for the work as classified in Chapter 4 or 5.

Exceptions:

1. The *code official* shall be authorized to accept existing floors and existing live loads and to approve

operational controls that limit the live load on any floor.

2. Repair of *substantial structural damage* is not required to comply with Sections 405.2.3 and 405.2.4. *Substantial structural damage* shall be repaired in accordance with Section 405.2.1.

[BS] 1205.2 Dangerous conditions. Conditions determined by the *code official* to be *dangerous* shall be remedied. Work shall not be required beyond what is required to remedy the *dangerous* condition.

SECTION 1206 RELOCATED BUILDINGS

1206.1 Relocated buildings. Foundations of relocated *historic buildings* and structures shall comply with the *International Building Code*. Relocated *historic buildings* shall otherwise be considered a *historic building* for the purposes of this code. Relocated *historic buildings* and structures shall be sited so that exterior wall and opening requirements comply with the *International Building Code* or with the compliance alternatives of this code.

**

CHAPTER 13

PERFORMANCE COMPLIANCE METHODS

User note:

About this chapter: Chapter 13 allows for existing buildings to be evaluated so as to show that alterations, while not meeting new construction requirements, will improve the current existing situation. Provisions are based on a numerical scoring system involving 19 various safety parameters and the degree of code compliance for each issue.

SECTION 1301 GENERAL

1301.1 Scope. The provisions of this chapter shall apply to the *alteration, addition and change of occupancy* of existing structures, including historic structures, as referenced in Section 301.3.3. The provisions of this chapter are intended to maintain or increase the current degree of public safety, health and general welfare in *existing buildings* while permitting, *alteration, addition and change of occupancy* without requiring full compliance with Chapters 6 through 12, except where compliance with other provisions of this code is specifically required in this chapter.

1301.1.1 Compliance with other methods. *Alterations, additions and changes of occupancy to existing structures* shall comply with the provisions of this chapter or with one of the methods provided in Section 301.3.

1301.2 Applicability. *Existing buildings* in which there is work involving *additions, alterations or changes of occupancy* shall be made to conform to the requirements of this chapter or the provisions of Chapters 6 through 10. The provisions of Sections 1301.2.1 through 1301.2.5 shall apply to existing occupancies that will continue to be, or are proposed to be, in Groups A, B, E, F, I-2, M, R and S. These provisions shall not apply to buildings with occupancies in Group H or I-1, I-3 or I-4.

1301.2.1 Change in occupancy. Where an *existing building* is changed to a new occupancy classification and this section is applicable, the provisions of this section for the new occupancy shall be used to determine compliance with this code.

1301.2.2 Partial change in occupancy. Where a portion of the building is changed to a new occupancy classification and that portion is separated from the remainder of the building with fire barrier or horizontal assemblies having a fire-resistance rating as required by Table 508.4 of the *International Building Code* or Section R302 of the *International Residential Code* for the separate occupancies, or with *approved* compliance alternatives, the portion changed shall be made to conform to the provisions of this section.

Where a portion of the building is changed to a new occupancy classification and that portion is not separated from the remainder of the building with fire barriers or horizontal assemblies having a fire-resistance rating as required by Table 508.4 of the *International Building*

Code or Section R302 of the *International Residential Code* for the separate occupancies, or with *approved* compliance alternatives, the provisions of this section which apply to each occupancy shall apply to the entire building. Where there are conflicting provisions, those requirements which secure the greater public safety shall apply to the entire building or structure.

1301.2.3 Additions. *Additions to existing buildings* shall comply with the requirements of the *International Building Code* or the *International Residential Code* for new construction. The combined height and area of the *existing building* and the new *addition* shall not exceed the height and area allowed by Chapter 5 of the *International Building Code*. Where a fire wall that complies with Section 706 of the *International Building Code* is provided between the *addition* and the *existing building*, the *addition* shall be considered a separate building.

1301.2.3.1 Additions to Group E facilities. For additions to Group E occupancies, storm shelters shall be provided in accordance with Section 1106.1.

1301.2.4 Alterations. An *existing building* or portion thereof shall not be altered in such a manner that results in the building being less safe or sanitary than such building is currently.

Exception: Where the current level of safety or sanitation is proposed to be reduced, the portion altered shall conform to the requirements of the *International Building Code*.

1301.2.5 Escalators. Where escalators are provided in below-grade transportation stations, existing and new escalators shall be permitted to have a clear width of less than 32 inches (815 mm).

1301.3 Acceptance. For *repairs, alterations, additions, and changes of occupancy to existing buildings* that are evaluated in accordance with this section, compliance with this section shall be accepted by the *code official*.

1301.3.1 Hazards. Where the *code official* determines that an *unsafe* condition exists as provided for in Section 115, such *unsafe* condition shall be abated in accordance with Section 115.

1301.3.2 Compliance with other codes. Buildings that are evaluated in accordance with this section shall comply with the *International Fire Code* and *International Property Maintenance Code*.

[BS]1301.3.3 Compliance with flood hazard provisions.

In *flood hazard areas*, buildings that are evaluated in accordance with this section shall comply with Section 1612 of the *International Building Code*, or Section R322 of the *International Residential Code*, as applicable if the work covered by this section constitutes *substantial improvement*.

1301.4 Investigation and evaluation. For proposed work covered by this chapter, the building owner shall cause the *existing building* to be investigated and evaluated in accordance with the provisions of Sections 1301.4 through 1301.9.

[BS] 1301.4.1 Structural analysis. The owner shall have a structural analysis of the *existing building* made to determine adequacy of structural systems for the proposed *alteration, addition or change of occupancy*. The analysis shall demonstrate that the building with the work completed is capable of resisting the loads specified in Chapter 16 of the *International Building Code*.

1301.4.2 Submittal. The results of the investigation and evaluation as required in Section 1301.4, along with proposed compliance alternatives, shall be submitted to the *code official*.

1301.4.3 Determination of compliance. The *code official* shall determine whether the *existing building*, with the proposed *addition, alteration, or change of occupancy*, complies with the provisions of this section in accordance with the evaluation process in Sections 1301.5 through 1301.9.

1301.5 Evaluation. The evaluation shall be composed of three categories: fire safety, means of egress, and general safety, as defined in Sections 1301.5.1 through 1301.5.3.

1301.5.1 Fire safety. Included within the fire safety category are the structural fire resistance, automatic fire detection, fire alarm, automatic sprinkler system and fire suppression system features of the *facility*.

1301.5.2 Means of egress. Included within the means of egress category are the configuration, characteristics, and support features for means of egress in the *facility*.

1301.5.3 General safety. Included within the general safety category are the fire safety parameters and the means of egress parameters.

1301.6 Evaluation process. The evaluation process specified herein shall be followed in its entirety to evaluate *existing buildings* in Groups A, B, E, F, M, R, S and U. For *existing buildings* in Group I-2, the evaluation process specified herein shall be followed and applied to each and every individual smoke compartment. Table 1301.7 shall be utilized for tabulating the results of the evaluation. References to other sections of this code or other codes indicate that compliance with those sections is required in order to gain credit in the evaluation herein outlined. In applying this section to a building with mixed occupancies, where the separation between the mixed occupancies does not qualify for any category indicated in Section 1301.6.16, the score for each occupancy shall be determined, and the lower score determined for each section of the evaluation process shall apply to the entire

building, or to each smoke compartment for Group I-2 occupancies.

Where the separation between the mixed occupancies qualifies for any category indicated in Section 1301.6.16, the score for each occupancy shall apply to each portion, or smoke compartment of the building based on the occupancy of the space.

1301.6.1 Building height and number of stories. The value for building height and number of stories shall be the lesser value determined by the formula in Section 1301.6.1.1. Section 504 of the *International Building Code* shall be used to determine the allowable height and number of stories of the building. Subtract the actual building height from the allowable height and divide by 12½ feet (3810 mm). Enter the height value and its sign (positive or negative) in Table 1301.7 under Safety Parameter 1301.6.1, Building Height, for fire safety, means of egress, and general safety. The maximum score for a building shall be 10.

1301.6.1.1 Height formula. The following formulas shall be used in computing the building height value.

$$\text{Height value, feet} = \frac{(AH) - (EBH)}{125} \times CF \tag{Equation 13-1}$$

$$\text{Height value, stories} = (AS - EBS) \times CF \tag{Equation 13-2}$$

where:

AH = Allowable height in feet (mm) from Section 504 of the *International Building Code*.

EBH = *Existing building* height in feet (mm).

AS = Allowable height in stories from Section 504 of the *International Building Code*.

EBS = *Existing building* height in stories.

CF = 1 if $(AH) - (EBH)$ is positive.

CF = Construction-type factor shown in Table 1301.6.6(2) if $(AH) - (EBH)$ is negative.

Note: Where mixed occupancies are separated and individually evaluated as indicated in Section 1301.6, the values *AH*, *AS*, *EBH* and *EBS* shall be based on the height of the occupancy being evaluated.

1301.6.2 Building area. The value for building area shall be determined by the formula in Section 1301.6.2.2. Section 506 of the *International Building Code* and the formula in Section 1301.6.2.1 shall be used to determine the allowable area of the building. Subtract the actual building area from the allowable area and divide by 1,200 square feet (112 m²). Enter the area value and its sign (positive or negative) in Table 1301.7 under Safety Parameter 1301.6.2, Building Area, for fire safety, means of egress and general safety. In determining the area value, the maximum permitted positive value for area is 50 percent of the fire safety score as listed in Table 1301.8, Mandatory Safety Scores. Group I-2 occupancies shall be scored zero.

1301.6.2.1 Allowable area formula. The following formula shall be used in computing allowable area:

$$A_a = A_t + (NS \times I_f) \quad \text{(Equation 13-3)}$$

where:

- A_a = Allowable building area per story (square feet).
- A_t = Tabular allowable area factor (NS, S1, S13R, or SM value, as applicable) in accordance with Table 506.2 of the *International Building Code*.
- NS = Tabular allowable area factor in accordance with Table 506.2 of the *International Building Code* for a nonsprinklered building (regardless of whether the building is sprinklered).
- I_f = Area factor increase due to frontage as calculated in accordance with Section 506.3 of the *International Building Code*.

1301.6.2.2 Area formula. The following formula shall be used in computing the area value. Determine the area value for each occupancy floor area on a floor-by-floor basis. For each occupancy, choose the minimum area value of the set of values obtained for the particular occupancy.

$$\text{Area value}_i = \frac{\text{Allowable area}_i}{1200 \text{ square feet}} \left[1 - \left(\frac{\text{Actual area}_i}{\text{Allowable area}_i} + \dots + \frac{\text{Actual area}_n}{\text{Allowable area}_n} \right) \right] \quad \text{(Equation 13-4)}$$

where:

- i = Value for an individual separated occupancy on a floor.
- n = Number of separated occupancies on a floor.

1301.6.3 Compartmentation. Evaluate the compartments created by fire barriers or horizontal assemblies which comply with Sections 1301.6.3.1 and 1301.6.3.2 and which are exclusive of the wall elements considered under Sections 1301.6.4 and 1301.6.5. Conforming compartments shall be figured as the net area and do not include shafts, chases, stairways, walls, or columns. Using Table 1301.6.3, determine the appropriate compartmentation value (CV) and enter that value into Table 1301.7 under Safety Parameter 1301.6.3, Compartmentation, for fire safety, means of egress, and general safety.

1301.6.3.1 Wall construction. A wall used to create separate compartments shall be a fire barrier conforming to Section 707 of the *International Building Code* with a fire-resistance rating of not less than 2 hours. Where the building is not divided into more than one compartment, the compartment size shall be taken as the total floor area on all floors. Where there is more than one compartment within a story, each compartmented area on such story shall be provided with a horizontal exit conforming to Section 1026 of the *International Building Code*. The fire door serving as the horizontal exit between compartments shall be so installed, fitted, and gasketed that such fire door will provide a substantial barrier to the passage of smoke.

1301.6.3.2 Floor/ceiling construction. A floor/ceiling assembly used to create compartments shall conform to Section 711 of the *International Building Code* and shall have a fire-resistance rating of not less than 2 hours.

1301.6.4 Tenant and dwelling unit separations. Evaluate the fire-resistance rating of floors and walls separating tenants, including dwelling units, and not evaluated under Sections 1301.6.3 and 1301.6.5. Group I-2 occupancies shall evaluate the rating of the separations between patient sleeping rooms.

Under the categories and occupancies in Table 1301.6.4, determine the appropriate value and enter that value in Table 1301.7 under Safety Parameter 1301.6.4, Tenant and Dwelling Unit Separation, for fire safety, means of egress, and general safety.

TABLE 1301.6.4 SEPARATION VALUES

OCCUPANCY	CATEGORIES				
	a	b	c	d	e
A-1	0	0	0	0	1
A-2	-5	-3	0	1	3
R	-4	-2	0	2	4
A-3, A-4, B, E, F, M, S-1	-4	-3	0	2	4
I-2	0	1	2	3	4
S-2	-5	-2	0	2	4

TABLE 1301.6.3 COMPARTMENTATION VALUES

OCCUPANCY	CATEGORIES				
	a Compartment size equal to or greater than 15,000 square feet	b Compartment size of 10,000 square feet	c Compartment size of 7,500 square feet	d Compartment size of 5,000 square feet	e Compartment size of 2,500 square feet or less
A-1, A-3	0	6	10	14	18
A-2	0	4	10	14	18
A-4, B, E, S-2	0	5	10	15	20
F, M, R, S-1	0	4	10	16	22

For SI: 1 square foot = 0.0929 m².

1301.6.4.1 Categories. The categories for tenant and dwelling unit separations are:

1. Category a—No fire partitions; incomplete fire partitions; no doors; doors not self-closing or automatic-closing.
2. Category b—Fire partitions or floor assemblies with less than 1-hour fire-resistance ratings or not constructed in accordance with Section 708 or 711 of the *International Building Code*, respectively.
3. Category c—Fire partitions with 1-hour or greater fire-resistance ratings constructed in accordance with Section 708 of the *International Building Code* and floor assemblies with 1-hour but less than 2-hour fire-resistance ratings constructed in accordance with Section 711 of the *International Building Code* or with only one tenant within the floor area.
4. Category d—Fire barriers with 1-hour but less than 2-hour fire-resistance ratings constructed in accordance with Section 707 of the *International Building Code* and floor assemblies with 2-hour or greater fire-resistance ratings constructed in accordance with Section 711 of the *International Building Code*.
5. Category e—Fire barriers and floor assemblies with 2-hour or greater fire-resistance ratings and constructed in accordance with Sections 707 and 711 of the *International Building Code*, respectively.

1301.6.5 Corridor walls. Evaluate the fire-resistance rating and degree of completeness of walls which create corridors serving the floor and that are constructed in accordance with Section 1020 of the *International Building Code*. This evaluation shall not include the wall elements considered under Sections 1301.6.3 and 1301.6.4. Under the categories and groups in Table 1301.6.5, determine the appropriate value and enter that value into Table 1301.7 under Safety Parameter 1301.6.5, Corridor Walls, for fire safety, means of egress, and general safety.

**TABLE 1301.6.5
CORRIDOR WALL VALUES**

OCCUPANCY	CATEGORIES			
	a	b	c ^a	d ^a
A-1	-10	-4	0	2
A-2	-30	-12	0	2
A-3, F, M, R, S-1	-7	-3	0	2
A-4, B, E, S-2	-5	-2	0	5
I-2	-10	0	1	2

a. Corridors not providing at least one-half the exit access travel distance for all occupants on a floor shall use Category b.

1301.6.5.1 Categories. The categories for corridor walls are:

1. Category a—No fire partitions; incomplete fire partitions; no doors; or doors not self-closing.
2. Category b—Less than 1-hour fire-resistance rating or not constructed in accordance with Section 708.4 of the *International Building Code*.

3. Category c—1-hour to less than 2-hour fire-resistance rating, with doors conforming to Section 716 of the *International Building Code* or without corridors as permitted by Section 1020 of the *International Building Code*.
4. Category d—2-hour or greater fire-resistance rating, with doors conforming to Section 716 of the *International Building Code*.

1301.6.6 Vertical openings. Evaluate the fire-resistance rating of interior exit stairways or ramps, hoistways, escalator openings, and other shaft enclosures within the building, and openings between two or more floors. Table 1301.6.6(1) contains the appropriate protection values. Multiply that value by the construction-type factor found in Table 1301.6.6(2). Enter the vertical opening value and its sign (positive or negative) in Table 1301.7 under Safety Parameter 1301.6.6, Vertical Openings, for fire safety, means of egress, and general safety. If the structure is a one-story building or if all the unenclosed vertical openings within the building conform to the requirements of Section 713 of the *International Building Code*, enter a value of 2. The maximum positive value for this requirement (VO) shall be 2.

**TABLE 1301.6.6(1)
VERTICAL OPENING PROTECTION VALUE**

PROTECTION	VALUE
None (unprotected opening)	-2 times number of floors connected
Less than 1 hour	-1 times number of floors connected
1 to less than 2 hours	1
2 hours or more	2

**TABLE 1301.6.6(2)
CONSTRUCTION-TYPE FACTOR**

F A C T O R	TYPE OF CONSTRUCTION								
	IA	IB	IIA	IIB	IIIA	IIIB	IV	VA	VB
	1.2	1.5	2.2	3.5	2.5	3.5	2.3	3.3	7

1301.6.6.1 Vertical opening formula. The following formula shall be used in computing vertical opening value.

$$VO = PV \times CF \tag{Equation 13-5}$$

where:

VO = Vertical opening value. The calculated value shall not be greater than positive 2.0.

PV = Protection value from Table 1301.6.6.(1).

CF = Construction-type factor from Table 1301.6.6.(2).

1301.6.7 HVAC systems. Evaluate the ability of the HVAC system to resist the movement of smoke and fire beyond the point of origin. Under the categories in Section 1301.6.7.1, determine the appropriate value and enter that value into Table 1301.7 under Safety Parameter 1301.6.7, HVAC Systems, for fire safety, means of egress, and general safety. Facilities in Group I-2 occupancies meeting Category a, b or c shall be considered to fail the evaluation.

1301.6.7.1 Categories. The categories for HVAC systems are:

1. Category a—Plenums not in accordance with Section 602 of the *International Mechanical Code*. -10 points.
2. Category b—Air movement in egress elements not in accordance with Section 1020.5 of the *International Building Code*. -5 points.
3. Category c—Both Categories a and b are applicable. -15 points.
4. Category d—Compliance of the HVAC system with Section 1020.5 of the *International Building Code* and Section 602 of the *International Mechanical Code*. 0 points.
5. Category e—Systems serving one story; or a central boiler/chiller system without ductwork connecting two or more stories. +5 points.

1301.6.8 Automatic fire detection. Evaluate the smoke detection capability based on the location and operation of automatic fire detectors in accordance with Section 907 of the *International Building Code* and the *International Mechanical Code*. Under the categories and occupancies in Table 1301.6.8, determine the appropriate value and enter that value into Table 1301.7 under Safety Parameter 1301.6.8, Automatic Fire Detection, for fire safety, means of egress, and general safety. Facilities in Group I-2 occupancies meeting Category a, b or c shall be considered to fail the evaluation.

**TABLE 1301.6.8
AUTOMATIC FIRE DETECTION VALUES**

OCCUPANCY	CATEGORIES					
	a	b	c	d	e	f
A-1, A-3, F, M, R, S-1	-10	-5	0	2	6	NA
A-2	-25	-5	0	5	9	NA
A-4, B, E, S-2	-4	-2	0	4	8	NA
I-2	NP	NP	NP	4	5	2

NA = Not Applicable.
NP = Not Permitted.

1301.6.8.1 Categories. The categories for automatic fire detection are:

1. Category a—None.
2. Category b—Existing smoke detectors in HVAC systems and maintained in accordance with the *International Fire Code*.
3. Category c—Smoke detectors in HVAC systems. The detectors are installed in accordance with the requirements for new buildings in the *International Mechanical Code*.
4. Category d—Smoke detectors throughout all floor areas other than individual sleeping units, tenant spaces and dwelling units.
5. Category e—Smoke detectors installed throughout the floor area.
6. Category f—Smoke detectors in corridors only.

1301.6.9 Fire alarm systems. Evaluate the capability of the fire alarm system in accordance with Section 907 of the *International Building Code*. Under the categories and occupancies in Table 1301.6.9, determine the appropriate value and enter that value into Table 1301.7 under Safety Parameter 1301.6.9, Fire Alarm System, for fire safety, means of egress, and general safety.

**TABLE 1301.6.9
FIRE ALARM SYSTEM VALUES**

OCCUPANCY	CATEGORIES			
	a	b ^a	c	d
A-1, A-2, A-3, A-4, B, E, R	-10	-5	0	5
F, M, S	0	5	10	15
I-2	-4	1	2	5

a. For buildings equipped throughout with an automatic sprinkler system, add 2 points for activation by a sprinkler water-flow device.

1301.6.9.1 Categories. The categories for fire alarm systems are:

1. Category a—None.
2. Category b—Fire alarm system with manual fire alarm boxes in accordance with Section 907.4 of the *International Building Code* and alarm notification appliances in accordance with Section 907.5.2 of the *International Building Code*.
3. Category c—Fire alarm system in accordance with Section 907 of the *International Building Code*.
4. Category d—Category c plus a required emergency voice/alarm communications system and a fire command station that conforms to Section 911 of the *International Building Code* and contains the emergency voice/alarm communications system controls, fire department communication system controls, and any other controls specified in Section 911 of the *International Building Code* where those systems are provided.

1301.6.10 Smoke control. Evaluate the ability of a natural or mechanical venting, exhaust, or pressurization system to control the movement of smoke from a fire. Under the categories and occupancies in Table 1301.6.10, determine the appropriate value and enter that value into Table 1301.7 under Safety Parameter 1301.6.10, Smoke Control, for means of egress and general safety.

**TABLE 1301.6.10
SMOKE CONTROL VALUES**

OCCUPANCY	CATEGORIES					
	a	b	c	d	e	f
A-1, A-2, A-3	0	1	2	3	6	6
A-4, E	0	0	0	1	3	5
B, M, R	0	2 ^a	3 ^a	3 ^a	3 ^a	4 ^a
F, S	0	2 ^a	2 ^a	3 ^a	3 ^a	3 ^a
I-2	-4	0	0	0	3	0

a. This value shall be 0 if compliance with Category d or e in Section 1301.6.8.1 has not been obtained.

1301.6.10.1 Categories. The categories for smoke control are:

1. Category a—None.
2. Category b—The building is equipped throughout with an automatic sprinkler system. Openings are provided in exterior walls at the rate of 20 square feet (1.86 m²) per 50 linear feet (15 240 mm) of exterior wall in each story and distributed around the building perimeter at intervals not exceeding 50 feet (15 240 mm). Such openings shall be readily openable from the inside without a key or separate tool and shall be provided with ready access thereto. In lieu of operable openings, clearly and permanently marked tempered glass panels shall be used.
3. Category c—One enclosed exit stairway, with ready access thereto, from each occupied floor of the building. The stairway has operable exterior windows, and the building has openings in accordance with Category b.
4. Category d—One smokeproof enclosure and the building has openings in accordance with Category b.
5. Category e—The building is equipped throughout with an automatic sprinkler system. Each floor area is provided with a mechanical air-handling system designed to accomplish smoke containment. Return and exhaust air shall be moved directly to the outside without recirculation to other floor areas of the building under fire conditions. The system shall exhaust not less than six air changes per hour from the floor area. Supply air by mechanical means to the floor area is not required. Containment of smoke shall be considered as confining smoke to the floor area involved without migration to other floor areas. Any other tested and *approved* design that will adequately accomplish smoke containment is permitted.
6. Category f—Each stairway shall be one of the following: a smokeproof enclosure in accordance with Section 1023.11 of the *International Building Code*; pressurized in accordance with Section 909.20.5 of the *International Building Code*; or shall have operable exterior windows.

1301.6.11 Means of egress capacity and number. Evaluate the means of egress capacity and the number of exits available to the building occupants. In applying this section, the means of egress are required to conform to the following sections of the *International Building Code*: 1003.7, 1004, 1005, 1006, 1007, 1016.2, 1026.1, 1028.2, 1028.5, 1029.2, 1029.3, 1029.4 and 1030. The number of exits credited is the number that is available to each occupant of the area being evaluated. Existing fire escapes shall be accepted as a component in the means of egress when conforming to Section 504.

Under the categories and occupancies in Table 1301.6.11, determine the appropriate value and enter that value into Table 1301.7 under Safety Parameter 1301.6.11, Means of Egress Capacity, for means of egress and general safety.

**TABLE 1301.6.11
MEANS OF EGRESS VALUES^a**

OCCUPANCY	CATEGORIES				
	a	b	c	d	e
A-1, A-2, A-3, A-4, E, I-2	-10	0	2	8	10
M	-3	0	1	2	4
B, F, S	-1	0	0	0	0
R	-3	0	0	0	0

a. The values indicated are for buildings six stories or less in height. For buildings over six stories above grade plane, add an additional -10 points.

1301.6.11.1 Categories. The categories for means-of-egress capacity and number of exits are:

1. Category a—Compliance with the minimum required means-of-egress capacity or number of exits is achieved through the use of a fire escape in accordance with Section 405.
2. Category b—Capacity of the means of egress complies with Section 1005 of the *International Building Code*, and the number of exits complies with the minimum number required by Section 1006 of the *International Building Code*.
3. Category c—Capacity of the means of egress is equal to or exceeds 125 percent of the required means-of-egress capacity, the means of egress complies with the minimum required width dimensions specified in the *International Building Code*, and the number of exits complies with the minimum number required by Section 1006 of the *International Building Code*.
4. Category d—The number of exits provided exceeds the number of exits required by Section 1006 of the *International Building Code*. Exits shall be located a distance apart from each other equal to not less than that specified in Section 1007 of the *International Building Code*.
5. Category e—The area being evaluated meets both Categories c and d.

1301.6.12 Dead ends. In spaces required to be served by more than one means of egress, evaluate the length of the exit access travel path in which the building occupants are confined to a single path of travel. Under the categories and occupancies in Table 1301.6.12, determine the appropriate value and enter that value into Table 1301.7 under Safety Parameter 1301.6.12, Dead Ends, for means of egress and general safety.

**TABLE 1301.6.12
DEAD-END VALUES**

OCCUPANCY	CATEGORIES ^a			
	a	b	c	d
A-1, A-3, A-4, B, F, M, R, S	-2	0	2	-4
A-2, E	-2	0	2	-4
I-2	-2	0	2	-6

a. For dead-end distances between categories, the dead-end value shall be obtained by linear interpolation.

1301.6.12.1 Categories. The categories for dead ends are:

1. Category a—Dead end of 35 feet (10 670 mm) in nonsprinklered buildings or 70 feet (21 340 mm) in sprinklered buildings.
2. Category b—Dead end of 20 feet (6096 mm); or 50 feet (15 240 mm) in Group B in accordance with Section 1020.4, Exception 2, of the *International Building Code*.
3. Category c—No dead ends; or ratio of length to width (l/w) is less than 2.5:1.
4. Category d—Dead ends exceeding Category a.

1301.6.13 Maximum exit access travel distance to an exit. Evaluate the length of exit access travel to an *approved* exit. Determine the appropriate points in accordance with the following equation and enter that value into Table 1301.7 under Safety Parameter 1301.6.13, Maximum Exit Access Travel Distance for means of egress and general safety. The maximum allowable exit access travel distance shall be determined in accordance with Section 1017.1 of the *International Building Code*.

$$\text{Points} = 20 \times \frac{\text{Maximum allowable travel distance} - \text{Maximum actual travel distance}}{\text{Maximum allowable travel distance}}$$

(Equation 13-6)

1301.6.14 Elevator control. Evaluate the passenger elevator equipment and controls that are available to the fire department to reach all occupied floors. Emergency recall and in-car operation of elevators shall be provided in accordance with the *International Fire Code*. Under the categories and occupancies in Table 1301.6.14, determine the appropriate value and enter that value into Table 1301.7 under Safety Parameter 1301.6.14, Elevator Control, for fire safety, means of egress and general safety. The values shall be zero for a single-story building.

**TABLE 1301.6.14
ELEVATOR CONTROL VALUES**

ELEVATOR TRAVEL	CATEGORIES			
	a	b	c	d
Less than 25 feet of travel above or below the primary level of elevator access for emergency fire-fighting or rescue personnel	-2	0	0	+2
Travel of 25 feet or more above or below the primary level of elevator access for emergency fire-fighting or rescue personnel	-4	NP	0	+4

For SI: 1 foot = 304.8 mm.

NP = Not Permitted.

1301.6.14.1 Categories. The categories for elevator controls are:

1. Category a—No elevator.
2. Category b—Any elevator without Phase I emergency recall operation and Phase II emergency in-car operation.

3. Category c—All elevators with Phase I emergency recall operation and Phase II emergency in-car operation as required by the *International Fire Code*.
4. Category d—All meet Category c; or Category b where permitted to be without Phase I emergency recall operation and Phase II emergency in-car operation; and at least one elevator that complies with new construction requirements serves all occupied floors.

1301.6.15 Means of egress emergency lighting. Evaluate the presence of and reliability of means of egress emergency lighting. Under the categories and occupancies in Table 1301.6.15, determine the appropriate value and enter that value into Table 1301.7 under Safety Parameter 1301.6.15, Means of Egress Emergency Lighting, for means of egress and general safety.

1301.6.15.1 Categories. The categories for means of egress emergency lighting are:

1. Category a—Means-of-egress lighting and exit signs not provided with emergency power in accordance with Section 2702 of the *International Building Code*.
2. Category b—Means of egress lighting and exit signs provided with emergency power in accordance with Section 2702 of the *International Building Code*.
3. Category c—Emergency power provided to means of egress lighting and exit signs, which provides protection in the event of power failure to the site or building.

**TABLE 1301.6.15
MEANS OF EGRESS EMERGENCY LIGHTING VALUES**

NUMBER OF EXITS REQUIRED BY SECTION 1006 OF THE INTERNATIONAL BUILDING CODE	CATEGORIES		
	a	b	c
Two or more exits	NP	0	4
Minimum of one exit	0	1	1

NP = Not Permitted.

1301.6.16 Mixed occupancies. Where a building has two or more occupancies that are not in the same occupancy classification, the separation between the mixed occupancies shall be evaluated in accordance with this section. Where there is no separation between the mixed occupancies or the separation between mixed occupancies does not qualify for any of the categories indicated in Section 1301.6.16.1, the building shall be evaluated as indicated in Section 1301.6, and the value for mixed occupancies shall be zero. Under the categories and occupancies in Table 1301.6.16, determine the appropriate value and enter that value into Table 1301.7 under Safety Parameter 1301.6.16, Mixed Occupancies, for fire safety and general safety. For buildings without mixed occupancies, the value shall be zero. Facilities in Group I-2 occupancies meeting Category a shall be considered to fail the evaluation.

PERFORMANCE COMPLIANCE METHODS

**TABLE 1301.6.16
MIXED OCCUPANCY VALUES^a**

OCCUPANCY	CATEGORIES		
	a	b	c
A-1, A-2, R	-10	0	10
A-3, A-4, B, E, F, M, S	-5	0	5
I-2	NP	0	5

NP = Not Permitted.

a. For fire-resistance ratings between categories, the value shall be obtained by linear interpolation.

1301.6.16.1 Categories. The categories for mixed occupancies are:

1. Category a—Occupancies separated by minimum 1-hour fire barriers or minimum 1-hour horizontal assemblies, or both.
2. Category b—Separations between occupancies in accordance with Section 508.4 of the *International Building Code*.
3. Category c—Separations between occupancies having a fire-resistance rating of not less than twice that required by Section 508.4 of the *International Building Code*.

1301.6.17 Automatic sprinklers. Evaluate the ability to suppress a fire based on the installation of an automatic sprinkler system in accordance with Section 903.3.1.1 of the *International Building Code*. “Required sprinklers” shall be based on the requirements of this code. Under the categories and occupancies in Table 1301.6.17, determine the appropriate value and enter that value into Table 1301.7 under Safety Parameter 1301.6.17, Automatic Sprinklers, for fire safety, means of egress divided by 2, and general safety. High-rise buildings defined in Chapter 2 of the *International Building Code* that undergo a *change of occupancy* to Group R shall be equipped throughout with an automatic sprinkler system in accordance with Section 403 of the *International Building Code* and Chapter 9 of the *International Building Code*. Facilities in Group I-2 occupancies meeting Category a, b, c or f shall be considered to fail the evaluation.

**TABLE 1301.6.17
SPRINKLER SYSTEM VALUES**

OCCUPANCY	CATEGORIES					
	a ^a	b ^a	c	d	e	f
A-1, A-3, F, M, R, S-1	-6	-3	0	2	4	6
A-2	-4	-2	0	1	2	4
A-4, B, E, S-2	-12	-6	0	3	6	12
I-2	NP	NP	NP	8	10	NP

NP = Not Permitted.

a. These options cannot be taken if Category a in Section 1301.6.18 is used.

1301.6.17.1 Categories. The categories for automatic sprinkler system protection are:

1. Category a—Sprinklers are required throughout; sprinkler protection is not provided or the sprinkler system design is not adequate for the hazard protected in accordance with Section 903 of the *International Building Code*.

2. Category b—Sprinklers are required in a portion of the building; sprinkler protection is not provided or the sprinkler system design is not adequate for the hazard protected in accordance with Section 903 of the *International Building Code*.
3. Category c—Sprinklers are not required; none are provided.
4. Category d—Sprinklers are required in a portion of the building; sprinklers are provided in such portion; the system is one that complied with the code at the time of installation and is maintained and supervised in accordance with Section 903 of the *International Building Code*.
5. Category e—Sprinklers are required throughout; sprinklers are provided throughout in accordance with Chapter 9 of the *International Building Code*.
6. Category f—Sprinklers are not required throughout; sprinklers are provided throughout in accordance with Chapter 9 of the *International Building Code*.

1301.6.18 Standpipes. Evaluate the ability to initiate attack on a fire by making a supply of water readily available through the installation of standpipes in accordance with Section 905 of the *International Building Code*. “Required Standpipes” shall be based on the requirements of the *International Building Code*. Under the categories and occupancies in Table 1301.6.18, determine the appropriate value and enter that value into Table 1301.7 under Safety Parameter 1301.6.18, Standpipes, for fire safety, means of egress, and general safety.

**TABLE 1301.6.18
STANDPIPE SYSTEM VALUES**

OCCUPANCY	CATEGORIES			
	a ^a	b	c	d
A-1, A-3, F, M, R, S-1	-6	0	4	6
A-2	-4	0	2	4
A-4, B, E, S-2	-12	0	6	12
I-2	-2	0	1	2

a. This option cannot be taken if Category a or Category b in Section 1301.6.17 is used.

1301.6.18.1 Standpipe categories. The categories for standpipe systems are:

1. Category a—Standpipes are required; standpipe is not provided or the standpipe system design is not in compliance with Section 905.3 of the *International Building Code*.
2. Category b—Standpipes are not required; none are provided.
3. Category c—Standpipes are required; standpipes are provided in accordance with Section 905 of the *International Building Code*.
4. Category d—Standpipes are not required; standpipes are provided in accordance with Section 905 of the *International Building Code*.

1301.6.19 Incidental uses. Evaluate the protection of incidental uses in accordance with Section 509.4.2 of the *International Building Code*. Do not include those where this code requires automatic sprinkler systems throughout the building including covered and open mall buildings, high-rise buildings, public garages and unlimited area buildings. Assign the lowest score from Table 1301.6.19 for the building or floor area being evaluated and enter that value into Table 1301.7 under Safety Parameter 1301.6.19, Incidental Uses, for fire safety, means of egress and general safety. If there are no specific occupancy areas in the building or floor area being evaluated, the value shall be zero.

1301.6.20 Smoke compartmentation. Evaluate the smoke compartments for compliance with Section 407.5 of the *International Building Code*. Under the categories and occupancies in Table 1301.6.20, determine the appropriate smoke compartmentation value (SCV) and enter that value into Table 1301.7 under Safety Parameter 1301.6.20, Smoke Compartmentation, for fire safety, means of egress and general safety. Facilities in Group I-2 occupancies meeting Category b or c shall be considered to fail the evaluation.

**TABLE 1301.6.20
SMOKE COMPARTMENTATION VALUES**

OCCUPANCY	CATEGORIES ^a		
	a	b	c
A, B, E, F, M, R and S	0	0	0
I-2	0	NP	NP

For SI: 1 square foot = 0.093 m².

NP = Not Permitted.

a. For areas between categories, the smoke compartmentation value shall be obtained by linear interpolation.

1301.6.20.1 Categories. Categories for smoke compartment size are:

1. Category a—Smoke compartment size is equal to or less than 22,500 square feet (2092 m²).

2. Category b—Smoke compartment size is greater than 22,500 square feet (2092 m²).
3. Category c—Smoke compartments are not provided.

1301.6.21 Patient ability, concentration, smoke compartment location and ratio to attendant. In I-2 occupancies, the ability of patients, their concentration and ratio to attendants shall be evaluated and applied in accordance with this section. Evaluate each smoke compartment using the categories in Sections 1301.6.21.1, 1301.6.21.2 and 1301.6.21.3 and enter the value in Table 1301.7. To determine the safety factor, multiply the three values together; if the sum is 9 or greater, compliance has failed.

1301.6.21.1 Patient ability for self-preservation.

Evaluate the ability of the patients for self-preservation in each smoke compartment in an emergency. Under the categories and occupancies in Table 1301.6.21.1, determine the appropriate value and enter that value in Table 1301.7 under Safety Parameter 1301.6.21.1, Patient Ability for Self-preservation, for means of egress and general safety.

**TABLE 1301.6.21.1
PATIENT ABILITY VALUES**

OCCUPANCY	CATEGORIES		
	a	b	c
I-2	1	2	3

1301.6.21.1.1 Categories. The categories for patient ability for self-preservation are:

1. Category a—(mobile) Patients are capable of self-preservation without assistance.
2. Category b—(not mobile) Patients rely on assistance for evacuation or relocation.
3. Category c—(not movable) Patients cannot be evacuated or relocated.

**TABLE 1301.6.19
INCIDENTAL USE AREA VALUES**

PROTECTION REQUIRED BY TABLE 509 OF THE INTERNATIONAL BUILDING CODE	PROTECTION PROVIDED						
	None	1 hour	AS	AS with CRS	1 hour and AS	2 hours	2 hours and AS
2 hours and AS	-4	-3	-2	-2	-1	-2	0
2 hours, or 1 hour and AS	-3	-2	-1	-1	0	0	0
1 hour and AS	-3	-2	-1	-1	0	-1	0
1 hour	-1	0	-1	-1	0	0	0
1 hour, or AS with CRS	-1	0	-1	-1	0	0	0
AS with CRS	-1	-1	-1	-1	0	-1	0
1 hour or AS	-1	0	0	0	0	0	0

AS = Automatic Sprinkler System;

CRS = Construction capable of resisting the passage of smoke (see IBC Section 509.4.2 of the *International Building Code*).

Note: For Table 1301.7, see page 71.

PERFORMANCE COMPLIANCE METHODS

1301.6.21.2 Patient concentration. Evaluate the concentration of patients in each smoke compartment under Section 1301.6.21.2. Under the categories and occupancies in Table 1301.6.21.2 determine the appropriate value and enter that value in Table 1301.7 under Safety Parameter 1301.6.21.2, Patient Concentration, for means of egress and general safety.

**TABLE 1301.6.21.2
PATIENT CONCENTRATION VALUES**

OCCUPANCY	CATEGORIES		
	a	b	c
I-2	1	2	3

1301.6.21.2.1 Categories: The categories for patient concentration are:

1. Category a—smoke compartment has 1 to 10 patients.
2. Category b—smoke compartment has more than 10 to 40 patients.
3. Category c—smoke compartment has more than 40 patients.

1301.6.21.3 Attendant-to-patient ratio. Evaluate the attendant-to-patient ratio for each compartment under Section 1301.6.21.3. Under the categories and occupancies in Table 1301.6.21.3 determine the appropriate value and enter that value in Table 1301.7 under Safety Parameter 1301.6.21.3, Attendant-to-patient Ratio, for means of egress and general safety.

1301.6.21.3.1 Categories. The categories for attendant-to-patient concentrations are:

1. Category a—attendant-to-patient concentration is 1:5.
2. Category b—attendant-to-patient concentration is 1:6 to 1:10.
3. Category c—attendant-to-patient concentration is greater than 1:10 or no patients.

**TABLE 1301.6.21.3
ATTENDANT-TO-PATIENT RATIO VALUES**

OCCUPANCY	CATEGORIES		
	a	b	c
I-2	1	2	3

1301.7 Building score. After determining the appropriate data from Section 1301.6, enter those data in Table 1301.7 and total the building score.

1301.8 Safety scores. The values in Table 1301.8 are the required mandatory safety scores for the evaluation process listed in Section 1301.6.

**TABLE 1301.8
MANDATORY SAFETY SCORES^a**

OCCUPANCY	FIRE SAFETY (MFS)	MEANS OF EGRESS (MME)	GENERAL SAFETY (MGS)
A-1	20	31	31
A-2	21	32	32
A-3	22	33	33
A-4, E	29	40	40
B	30	40	40
F	24	34	34
I-2	19	34	34
M	23	40	40
R	21	38	38
S-1	19	29	29
S-2	29	39	39

- a. MFS = Mandatory Fire Safety.
MME = Mandatory Means of Egress.
MGS = Mandatory General Safety.

1301.9 Evaluation of building safety. The mandatory safety score in Table 1301.8 shall be subtracted from the building score in Table 1301.7 for each category in accordance with the evaluation formulas in Table 1301.9. Where the final score for any category equals zero or more, the building is in compliance with the requirements of this section for that category. Where the final score for any category is less than zero, the building is not in compliance with the requirements of this section.

1301.9.1 Mixed occupancies. For mixed occupancies, the following provisions shall apply:

1. Where the separation between mixed occupancies does not qualify for any category indicated in Section 1301.6.16, the mandatory safety scores for the occupancy with the lowest general safety score in Table 1301.8 shall be utilized (see Section 1301.6).
2. Where the separation between mixed occupancies qualifies for any category indicated in Section 1301.6.16, the mandatory safety scores for each occupancy shall be placed against the evaluation scores for the appropriate occupancy.

**TABLE 1301.9
EVALUATION FORMULAS^a**

FORMULA	T1301.7	T1301.8		SCORE	PASS	FAIL
FS – MFS ≥ 0	_____ (FS) –	_____ (MFS)	=	_____	_____	_____
ME – MME ≥ 0	_____ (ME) –	_____ (MME)	=	_____	_____	_____
GS – MGS ≥ 0	_____ (GS) –	_____ (MGS)	=	_____	_____	_____

- a. FS = Fire Safety.
ME = Means of Egress.
GS = General Safety.

- MFS = Mandatory Fire Safety.
MME = Mandatory Means of Egress.
MGS = Mandatory General Safety.

**TABLE 1301.7
SUMMARY SHEET—BUILDING CODE**

Existing occupancy: _____	Proposed occupancy: _____
Year building was constructed: _____	Number of stories: _____ Height in feet: _____
Type of construction: _____	Area per floor: _____
Percentage of open perimeter increase: _____ %	
Completely suppressed: Yes _____ No _____	Corridor wall rating: _____
	Type: _____
Compartmentation: Yes _____ No _____	Required door closers: Yes _____ No _____
Fire-resistance rating of vertical opening enclosures: _____	
Type of HVAC system: _____, serving number of floors: _____	
Automatic fire detection: Yes _____ No _____	Type and location: _____
Fire alarm system: Yes _____ No _____	Type: _____
Smoke control: Yes _____ No _____	Type: _____
Adequate exit routes: Yes _____ No _____	Dead ends: _____ Yes _____ No _____
Maximum exit access travel distance: _____	Elevator controls: Yes _____ No _____
Means of egress emergency lighting: Yes _____ No _____	Mixed occupancies: Yes _____ No _____
Standpipes: Yes _____ No _____	Patient ability for self-preservation: _____
Incidental use: Yes _____ No _____	Patient concentration: _____
Smoke compartmentation less than 22,500 sq. feet (2092 m ²): Yes _____ No _____	Attendant-to-patient ratio: _____

SAFETY PARAMETERS	FIRE SAFETY (FS)	MEANS OF EGRESS (ME)	GENERAL SAFETY (GS)
1301.6.1 Building height 1301.6.2 Building area 1301.6.3 Compartmentation			
1301.6.4 Tenant and dwelling unit separations 1301.6.5 Corridor walls 1301.6.6 Vertical openings			
1301.6.7 HVAC systems 1301.6.8 Automatic fire detection 1301.6.9 Fire alarm system			
1301.6.10 Smoke control 1301.6.11 Means of egress 1301.6.12 Dead ends	***		
1301.6.13 Maximum exit access travel distance 1301.6.14 Elevator control 1301.6.15 Means of egress emergency lighting	***		
1301.6.16 Mixed occupancies 1301.6.17 Automatic sprinklers 1301.6.18 Standpipes 1301.6.19 Incidental use 1301.6.20 Smoke compartmentation		*** ÷ 2 =	
1301.6.21.1 Patient ability for self-preservation ^a 1301.6.21.2 Patient concentration ^a 1301.6.21.3 Attendant-to-patient ratio ^a	*** *** ***		
Building score—total value			

***No applicable value to be inserted.
a. Only applicable to Group I-2 occupancies.

CHAPTER 14

RELOCATED OR MOVED BUILDINGS

User note:

About this chapter: Chapter 14 is applicable to any building that is moved or relocated. The relocation of a building will automatically cause an inspection and evaluation process that enables the jurisdiction to determine the level of compliance with the International Fire Code® and the International Property Maintenance Code®. These two codes, by their scope, are applicable to existing buildings. This is the case regardless of any repair, remodeling, alteration work or change of occupancy occurring (see the International Fire Code and International Property Maintenance Code).

SECTION 1401 GENERAL

1401.1 Scope. This chapter provides requirements for relocated or moved structures, including *relocatable buildings* as defined in Chapter 2.

1401.2 Conformance. The building shall be safe for human occupancy as determined by the *International Fire Code* and the *International Property Maintenance Code*. Any repair, alteration or change of occupancy undertaken within the moved structure shall comply with the requirements of this code applicable to the work being performed. Any field-fabricated elements shall comply with the requirements of the *International Building Code* or the *International Residential Code* as applicable.

SECTION 1402 REQUIREMENTS

1402.1 Location on the lot. The building shall be located on the lot in accordance with the requirements of the *International Building Code* or the *International Residential Code* as applicable.

[BS] 1402.2 Foundation. The foundation system of relocated buildings shall comply with the *International Building Code* or the *International Residential Code* as applicable.

[BS] 1402.2.1 Connection to the foundation. The connection of the relocated building to the foundation shall comply with the *International Building Code* or the *International Residential Code* as applicable.

[BS] 1402.3 Wind loads. Buildings shall comply with *International Building Code* or *International Residential Code* wind provisions as applicable.

Exceptions:

1. Detached one- and two-family dwellings and Group U occupancies where wind loads at the new location are not higher than those at the previous location.
2. Structural elements whose stress is not increased by more than 10 percent.

[BS] 1402.4 Seismic loads. Buildings shall comply with *International Building Code* or *International Residential Code* seismic provisions at the new location as applicable.

Exceptions:

1. Structures in Seismic Design Categories A and B and detached one- and two-family dwellings in Seismic Design Categories A, B and C where the seismic loads at the new location are not higher than those at the previous location.
2. Structural elements whose stress is not increased by more than 10 percent.

[BS] 1402.5 Snow loads. Structures shall comply with *International Building Code* or *International Residential Code* snow loads as applicable where snow loads at the new location are higher than those at the previous location.

Exception: Structural elements whose stress is not increased by more than 5 percent.

[BS] 1402.6 Flood hazard areas. If relocated or moved into a *flood hazard area*, structures shall comply with Section 1612 of the *International Building Code*, or Section R322 of the *International Residential Code*, as applicable.

[BS] 1402.7 Required inspection and repairs. The *code official* shall be authorized to inspect, or to require *approved* professionals to inspect at the expense of the owner, the various structural parts of a relocated building to verify that structural components and connections have not sustained structural damage. Any *repairs* required by the *code official* as a result of such inspection shall be made prior to the final approval.

CHAPTER 15

CONSTRUCTION SAFEGUARDS

User note:

About this chapter: The building construction process involves a number of known and unanticipated hazards. Chapter 15 establishes specific regulations in order to minimize the risk to the public and adjacent property. Some construction failures have resulted during the initial stages of grading, excavation and demolition. During these early stages, poorly designed and installed sheeting and shoring have resulted in ditch and embankment cave-ins. Also, inadequate underpinning of adjoining existing structures or careless removal of existing structures has produced construction failures.

SECTION 1501 GENERAL

[BG] 1501.1 Scope. The provisions of this chapter shall govern safety during construction and the protection of adjacent public and private properties.

[BG] 1501.2 Storage and placement. Construction equipment and materials shall be stored and placed so as not to endanger the public, the workers or adjoining property for the duration of the construction project.

[BG] 1501.3 Alterations, repairs and additions. Required exits, existing structural elements, fire protection devices and sanitary safeguards shall be maintained at all times during alterations, repairs or additions to any building or structure.

Exceptions:

1. Where such required elements or devices are being altered or repaired, adequate substitute provisions shall be made.
2. Maintenance of such elements and devices is not required where the *existing building* is not occupied.

[BG] 1501.4 Manner of removal. Waste materials shall be removed in a manner that prevents injury or damage to persons, adjoining properties and public rights-of-way.

[BG] 1501.5 Fire safety during construction. Fire safety during construction shall comply with the applicable requirements of the *International Building Code* and the applicable provisions of Chapter 33 of the *International Fire Code*.

[BS] 1501.6 Protection of pedestrians. Pedestrians shall be protected during construction and demolition activities as required by Sections 1501.6.1 through 1501.6.7 and Table 1501.6. Signs shall be provided to direct pedestrian traffic.

[BS] 1501.6.1 Walkways. A walkway shall be provided for pedestrian travel in front of every construction and demolition site unless the applicable governing authority authorizes the sidewalk to be fenced or closed. A walkway shall be provided for pedestrian travel that leads from a building entrance or exit of an occupied structure to a public way. Walkways shall be of sufficient width to accommodate the pedestrian traffic, but shall be not less than 4 feet (1219 mm) in width. Walkways shall be provided with a durable walking surface and shall be accessible in accordance with Chapter 11 of the *International Building Code*. Walkways shall be designed to support all imposed loads and the design live load shall be not less than 150 pounds per square foot (psf) (7.2 kN/m²).

[BS] 1501.6.2 Directional barricades. Pedestrian traffic shall be protected by a directional barricade where the walkway extends into the street. The directional barricade shall be of sufficient size and construction to direct vehicular traffic away from the pedestrian path.

[BS] 1501.6.3 Construction railings. Construction railings shall be not less than 42 inches (1067 mm) in height and shall be sufficient to direct pedestrians around construction areas.

**[BS] TABLE 1501.6
PROTECTION OF PEDESTRIANS**

HEIGHT OF CONSTRUCTION	DISTANCE OF CONSTRUCTION TO LOT LINE	TYPE OF PROTECTION REQUIRED
8 feet or less	Less than 5 feet	Construction railings
	5 feet or more	None
More than 8 feet	Less than 5 feet	Barrier and covered walkway
	5 feet or more, but not more than one-fourth the height of construction	Barrier and covered walkway
	5 feet or more, but between one-fourth and one-half the height of construction	Barrier
	5 feet or more, but exceeding one-half the height of construction	None

For SI: 1 foot = 304.8 mm.

CONSTRUCTION SAFEGUARDS

[BS] 1501.6.4 Barriers. Barriers shall be not less than 8 feet (2438 mm) in height and shall be placed on the side of the walkway nearest the construction. Barriers shall extend the entire length of the construction site. Openings in such barriers shall be protected by doors that are normally kept closed.

[BS] 1501.6.4.1 Barrier design. Barriers shall be designed to resist loads required in Chapter 16 of the *International Building Code* unless constructed as follows:

1. Barriers shall be provided with 2-inch by 4-inch (51 mm by 102 mm) top and bottom plates.
2. The barrier material shall be boards not less than $\frac{3}{4}$ inch (19.1 mm) in thickness or wood structural use panels not less than $\frac{1}{4}$ inch (6.4 mm) in thickness.
3. Wood structural use panels shall be bonded with an adhesive identical to that for exterior wood structural use panels.
4. Wood structural use panels $\frac{1}{4}$ inch (6.4 mm) or $\frac{5}{16}$ inch (23.8 mm) in thickness shall have studs spaced not more than 2 feet (610 mm) on center.
5. Wood structural use panels $\frac{3}{8}$ inch (9.5 mm) or $\frac{1}{2}$ inch (12.7 mm) in thickness shall have studs spaced not more than 4 feet (1219 mm) on center, provided that a 2-inch by 4-inch (51 mm by 102 mm) stiffener is placed horizontally at mid-height where the stud spacing is greater than 2 feet (610 mm) on center.
6. Wood structural use panels $\frac{5}{8}$ inch (15.9 mm) or thicker shall not span over 8 feet (2438 mm).

[BS] 1501.6.5 Covered walkways. Covered walkways shall have a clear height of not less than 8 feet (2438 mm) as measured from the floor surface to the canopy overhead. Adequate lighting shall be provided at all times. Covered walkways shall be designed to support all imposed loads. The design live load shall be not less than 150 psf (7.2 kN/m²) for the entire structure.

Exception: Roofs and supporting structures of covered walkways for new, light-frame construction not exceeding two stories above grade plane are permitted to be designed for a live load of 75 psf (3.6 kN/m²) or the loads imposed on them, whichever is greater. In lieu of such designs, the roof and supporting structure of a covered walkway are permitted to be constructed as follows:

1. Footings shall be continuous 2-inch by 6-inch (51 mm by 152 mm) members.
2. Posts not less than 4 inches by 6 inches (102 mm by 152 mm) shall be provided on both sides of the roof and spaced not more than 12 feet (3658 mm) on center.
3. Stringers not less than 4 inches by 12 inches (102 mm by 305 mm) shall be placed on edge on the posts.
4. Joists resting on the stringers shall be not less than 2 inches by 8 inches (51 mm by 203 mm)

and shall be spaced not more than 2 feet (610 mm) on center.

5. The deck shall be planks not less than 2 inches (51 mm) thick or wood structural panels with an exterior exposure durability classification not less than $\frac{23}{32}$ inch (18.3 mm) thick nailed to the joists.
6. Each post shall be knee-braced to joists and stringers by members not less than 2 inches by 4 inches (51 mm by 102 mm); 4 feet (1219 mm) in length.
7. A curb that is not less than 2 inches by 4 inches (51 mm by 102 mm) shall be set on edge along the outside edge of the deck.

[BS] 1501.6.6 Repair, maintenance and removal. Pedestrian protection required by Section 1501.6 shall be maintained in place and kept in good order for the entire length of time pedestrians are subject to being endangered. The owner or the owner's authorized agent, on completion of the construction activity, shall immediately remove walkways, debris and other obstructions and leave such public property in as good a condition as it was before such work was commenced.

[BS] 1501.6.7 Adjacent to excavations. Every excavation on a site located 5 feet (1524 mm) or less from the street lot line shall be enclosed with a barrier not less than 6 feet (1829 mm) in height. Where located more than 5 feet (1524 mm) from the street lot line, a barrier shall be erected where required by the *code official*. Barriers shall be of adequate strength to resist wind pressure as specified in Chapter 16 of the *International Building Code*.

1501.7 Facilities required. Sanitary facilities shall be provided during construction or demolition activities in accordance with the *International Plumbing Code*.

SECTION 1502 PROTECTION OF ADJOINING PROPERTY

[BS] 1502.1 Protection required. Adjoining public and private property shall be protected from damage during construction and demolition work. Protection must be provided for footings, foundations, party walls, chimneys, skylights and roofs. Provisions shall be made to control water runoff and erosion during construction or demolition activities. The person making or causing an excavation to be made shall provide written notice to the owners of adjoining buildings advising them that the excavation is to be made and that the adjoining buildings should be protected. Said notification shall be delivered not less than 10 days prior to the scheduled starting date of the excavation.

SECTION 1503 TEMPORARY USE OF STREETS, ALLEYS AND PUBLIC PROPERTY

[BG] 1503.1 Storage and handling of materials. The temporary use of streets or public property for the storage or handling of materials or equipment required for construction or demolition, and the protection provided to the public shall

comply with the provisions of the applicable governing authority and this chapter.

[BG] 1503.2 Obstructions. Construction materials and equipment shall not be placed or stored so as to obstruct access to fire hydrants, standpipes, fire or police alarm boxes, catch basins or manholes, nor shall such material or equipment be located within 20 feet (6096 mm) of a street intersection, or placed so as to obstruct normal observations of traffic signals or to hinder the use of public transit loading platforms.

[BG] 1503.3 Utility fixtures. Building materials, fences, sheds or any obstruction of any kind shall not be placed so as to obstruct free approach to any fire hydrant, fire department connection, utility pole, manhole, fire alarm box, or catch basin, or so as to interfere with the passage of water in the gutter. Protection against damage shall be provided to such utility fixtures during the progress of the work, but sight of them shall not be obstructed.

SECTION 1504 FIRE EXTINGUISHERS

[F] 1504.1 Where required. Structures under construction, alteration or demolition shall be provided with not fewer than one approved portable fire extinguisher in accordance with Section 906 of the *International Fire Code* and sized for not less than ordinary hazard as follows:

1. At each stairway on all floor levels where combustible materials have accumulated.
2. In every storage and construction shed.
3. Additional portable fire extinguishers shall be provided where special hazards exist, such as the storage and use of flammable and combustible liquids.

[F] 1504.2 Fire hazards. The provisions of this code and of the *International Fire Code* shall be strictly observed to safeguard against all fire hazards attendant upon construction operations.

SECTION 1505 MEANS OF EGRESS

[BE] 1505.1 Stairways required. Where building construction exceeds 40 feet (12 192 mm) in height above the lowest level of fire department vehicle access, a temporary or permanent stairway shall be provided. As construction progresses, such stairway shall be extended to within one floor of the highest point of construction having secured decking or flooring.

[F] 1505.2 Maintenance of means of egress. Means of egress and required accessible means of egress shall be maintained at all times during construction, demolition, remodeling or alterations and additions to any building.

Exception: Existing means of egress need not be maintained where approved temporary means of egress and accessible means of egress systems and facilities are provided.

SECTION 1506 STANDPIPES

[F] 1506.1 Where required. In buildings required to have standpipes by Section 905.3.1 of the *International Building*

Code, not less than one standpipe shall be provided for use during construction. Such standpipes shall be installed prior to construction exceeding 40 feet (12 192 mm) in height above the lowest level of fire department vehicle access. Such standpipes shall be provided with fire department hose connections at locations adjacent to stairways, complying with Section 1505.1. As construction progresses, such standpipes shall be extended to within one floor of the highest point of construction having secured decking or flooring.

[F] 1506.2 Buildings being demolished. Where a building or portion of a building is being demolished and a standpipe is existing within such a building, such standpipe shall be maintained in an operable condition so as to be available for use by the fire department. Such standpipe shall be demolished with the building but shall not be demolished more than one floor below the floor being demolished.

[F] 1506.3 Detailed requirements. Standpipes shall be installed in accordance with the provisions of Chapter 9 of the *International Building Code*.

Exception: Standpipes shall be either temporary or permanent in nature, and with or without a water supply, provided that such standpipes conform to the requirements of Section 905 of the *International Building Code* as to capacity, outlets and materials.

SECTION 1507 AUTOMATIC SPRINKLER SYSTEM

[F] 1507.1 Completion before occupancy. In buildings where an automatic sprinkler system is required by this code or the *International Building Code*, it shall be unlawful to occupy any portions of a building or structure until the automatic sprinkler system installation has been tested and approved, except as provided in Section 110.3.

[F] 1507.2 Operation of valves. Operation of sprinkler control valves shall be permitted only by properly authorized personnel and shall be accompanied by notification of duly designated parties. When the sprinkler protection is being regularly turned off and on to facilitate connection of newly completed segments, the sprinkler control valves shall be checked at the end of each work period to ascertain that protection is in service.

SECTION 1508 ACCESSIBILITY

[BE] 1508.1 Construction sites. Structures, sites, and equipment directly associated with the actual process of construction, including but not limited to scaffolding, bridging, material hoists, material storage, or construction trailers are not required to be accessible.

SECTION 1509 WATER SUPPLY FOR FIRE PROTECTION

[F] 1509.1 When required. An approved water supply for fire protection, either temporary or permanent, shall be made available as soon as combustible material arrives on the site.

CHAPTER 16

REFERENCED STANDARDS

User note:

About this chapter: This code contains numerous references to standards that are used to regulate materials and methods of construction. Chapter 16 contains a comprehensive list of all standards that are referenced in the code, including the appendices. The standards are part of the code to the extent of the reference to the standard. Compliance with the referenced standard is necessary for compliance with this code. By providing specifically adopted standards, the construction and installation requirements necessary for compliance with the code can be readily determined. The basis for code compliance is, therefore, established and available on an equal basis to the building code official, contractor, designer and owner.

This chapter lists the standards that are referenced in various sections of this document. The standards are listed herein by the promulgating agency of the standard, the standard identification, the effective date and title, and the section or sections of this document that reference the standard. The application of the referenced standards shall be as specified in Section 102.4.

ASCE/SEI

American Society of Civil Engineers
Structural Engineering Institute
1801 Alexander Bell Drive
Reston, VA 20191-4400

7—16: Minimum Design Loads and Associated Criteria for Buildings and Other Structures

303.2, 303.3.1, 503.4, 503.12, 800.3, 806.4

41—17: Seismic Evaluation and Retrofit of Existing Buildings

303.3.1, Table 303.3.1, 303.3.2, Table 303.3.2

ASHRAE

ASHRAE
1791 Tullie Circle, NE
Atlanta, GA 30329

62.1—2016: Ventilation for Acceptable Indoor Air Quality

808.2

ASME

American Society of Mechanical Engineers
Two Park Avenue
New York, NY 10016

ASME A17.1—2016/CSA B44—16: Safety Code for Elevators and Escalators

305.8.2, 902.1.2

A17.3—2015: Safety Code for Existing Elevators and Escalators

902.1.2

A18.1—2014: Safety Standard for Platform Lifts and Stairway Chair Lifts

305.8.3

REFERENCED STANDARDS

ASTM

ASTM International
100 Barr Harbor Drive, P.O. Box C700
West Conshohocken, PA 19428-2959

C94/C94M—15A: Specification for Ready-mixed Concrete
109.3.1

E84—2016: Standard Test Method for Surface Burning Characteristics of Building Materials
1204.9

E108—16: Standard Test Methods for Fire Tests of Roof Coverings
1204.5

E136—16: Test Method for Behavior of Materials in a Vertical Tube Furnace at 750°C
202

F2006—17: Standard Safety Specification for Window Fall Prevention Devices for Non Emergency Escape (Egress) and Rescue (Ingress) Windows
505.2, 702.4

F2090—17: Standard Specification for Window Fall Prevention Devices with Emergency (Egress) Release Mechanisms
505.2, 505.3, 702.4, 702.5

ICC

International Code Council, Inc.
500 New Jersey Avenue, NW
6th Floor
Washington, DC 20001

IBC—18: International Building Code®

101.4.1, 104.2.1, 106.2.2, 109.3.3, 109.3.6, 109.3.9, 110.2, 202, 301.3, 302.5.1, 302.6, 303.1, 303.3.1, 303.3.2, 304, 305.4, 305.4.2, 305.6, 305.8.1, 305.8.4, 305.8.5, 305.8.6, 305.8.7, 305.8.8, 305.8.10, 305.8.11, 305.8.15, 305.9, 305.9.3, 305.9.4, 401.2, 402.3, 405.2.1.1, 405.2.3.1, 405.2.3.3, 405.2.4, 405.2.5, 501.2, 502.1, 502.3, 502.4, 502.5, 503.1, 503.2, 503.3, 503.4, 503.5, 503.11, 503.12, 503.13, 503.16.1, 503.16.2, 503.16.3, 505.2, 505.3, 505.4, 506.1, 506.3, 506.4.1, 506.4.2, 506.4.3, 506.4.4, 507.3, 701.2, 701.3, 701.4, 702.1, 702.2, 702.3, 702.4, 702.5, 702.6, 705.1, 706.2, 801.3, 802.2.1, 802.2.3, 802.3, 802.4, 802.5.2, 802.6, 803.1.1, 803.2, 803.2.2, 803.2.3, 803.3, 805.3.1, 805.3.1.1, Table 805.3.1.1(1), 805.3.1.2.1, 805.4.3, 805.4.5, 805.5, 805.6, 805.7.1, 805.8.1, 805.9.2, 805.10.1.1, 805.10.1.2, 805.10.1.3, 805.10.2, 805.11.2, 806.2, 806.3, 806.4, 904.1.2, 904.1.3, 904.1.4, 904.2, 904.2.1, 904.2.2, 905.2, 905.3, 906.2, 906.3, 1001.2, 1001.3, 1002.1, 1002.2, 1004.1, 1006.1, 1006.2, 1006.3, 1006.4, 1010.1, 1011.1, 1011.1.1.1, 1011.1.1.2, 1011.2.1, 1011.2.2, 1011.3, 1011.4.1, 1011.4.2, 1011.4.3, 1011.5.1, 1011.5.1.1, 1011.5.3, 1011.6.1, 1011.6.3, 1011.7.1, 1011.7.2, 1011.7.3, 1102.1, 1102.2, 1102.3, 1103.1, 1103.2, 1103.3, 1201.4, 1202.2, 1203.12, 1204.2, 1204.9, 1206.1, 1301.2.2, 1301.2.3, 1301.2.4, 1301.3.3, 1301.4.1, 1301.6.1, 1301.6.1.1, 1301.6.2, 1301.6.2.1, 1301.6.3.1, 1301.6.3.2, 1301.6.4.1, 1301.6.5, 1301.6.5.1, 1301.6.6, 1301.6.7.1, 1301.6.8, 1301.6.9, 1301.6.9.1, 1301.6.10, 1301.6.10.1, 1301.6.11, 1301.6.11.1, 1301.6.12.1, 1301.6.13, 1301.6.15.1, 1301.6.16.1, 1301.6.17, 1301.6.17.1, 1301.6.18, 1301.6.18.1, 1301.6.19, Table 1301.6.19, 1301.6.20, 1401.2, 1402.1, 1402.2, 1402.2.1, 1402.3, 1402.4, 1402.5, 1402.6, 1501.5, 1501.6.1, 1501.6.4.1, 1501.6.7, 1506.3

ICC A117.1—09: Accessible and Usable Buildings and Facilities
301.5, 305.8.2, 305.8.3, 305.8.10

ICC 300—17: ICC Standard on Bleachers, Folding and Telescopic Seating and Grandstands
501.1

ICC 500—14: Standard for the Design and Construction of Storm Shelters
1106.1

IECC—18: International Energy Conservation Code®
302.3, 702.6, 707.1, 810.1, 907.1, 1107.1

IFC—18: International Fire Code®
101.4.2, 301.3.1, 302.3, 502.6, 502.7, 503.14, 503.15, 802.2.1, 802.2.3, 803.4.1.1, 803.4.1.2, 803.4.1.3, 803.4.1.4, 803.4.1.5, 803.4.1.6, 803.4.1.7, 803.4.3, 804.1, 1011.5.1.1, 1104.1, 1105.1, 1301.3.2, 1301.6.8.1, 1301.6.14, 1304.6.14.1, 1401.2, 1501.5, 1504.1, 1504.2

IFGC—18: International Fuel Gas Code®
302.3, 702.6.1

ICC—continued

IMC—18: International Mechanical Code®

302.3, 702.6, 808.1, 902.1.1, 1008.1, 1301.6.7.1, 1301.6.8, 1301.6.8.1

IPC—18: International Plumbing Code®

302.3, 408.1, 702.6, 809.1, 1009.1, 1009.2, 1009.3, 1009.5, 1501.7

IPMC—18: International Property Maintenance Code®

101.4.2, 302.3, 1301.3.2, 1401.2

IRC—18: International Residential Code®

101.2, 101.4.1, 302.3, 401.3, 402.3, 405.2.5, 502.3, 502.4, 502.5, 502.7, 503.2, 503.3, 503.11, 505.2, 505.3, 507.3, 701.3, 702.4, 702.5, 706.2, 707.1, 806.2, 807.3, 810.1, 906.2, 907.1, 1103.1, 1103.2, 1103.3, 1103.4, 1104.1, 1105.1, 1107.1, 1201.4, 1301.2.2, 1301.2.3, 1301.3.3, 1401.2, 1402.1, 1402.2, 1402.2.1, 1402.3, 1402.4, 1402.5, 1402.6

NFPA

National Fire Protection Agency
1 Batterymarch Park
Quincy, MA 02169-7471

NFPA 13R—16: Standard for the Installation of Sprinkler Systems in Residential Occupancies up to and Including Four Stories in Height

803.2.4

NFPA 70—17: National Electrical Code

107.3, 302.3, 406.1.1, 406.1.2, 406.1.3, 406.1.4, 406.1.5, 807.1, 807.3.4, 807.3.7, 1007.1, 1007.2, 1007.3, 1007.4

NFPA 72—16: National Fire Alarm and Signaling Code

803.2.4, 803.4

NFPA 99—18: Health Care Facilities Code

406.1.4

NFPA 101—18: Life Safety Code

805.2

UL

UL LLC
333 Pfingsten Road
Northbrook, IL 60062

723—08: Standard for Test for Surface Burning Characteristics of Building Materials—with Revisions through August 2013

1204.9

790—04: Standard Test Methods for Fire Tests of Roof Coverings—with Revisions through July 2014

1204.5

Appendix A: Guidelines for the Seismic Retrofit of Existing Buildings

CHAPTER A1

SEISMIC STRENGTHENING PROVISIONS FOR UNREINFORCED MASONRY BEARING WALL BUILDINGS

User note:

About this appendix: Appendix A provides guidelines for upgrading the seismic-resistance capacity of different types of existing buildings. It is organized into separate chapters that deal with buildings of different types, including unreinforced masonry buildings, reinforced concrete and reinforced masonry wall buildings, and light-frame wood buildings.

SECTION A101 PURPOSE

[BS] A101.1 Purpose. The purpose of this chapter is to promote public safety and welfare by reducing the risk of death or injury from the effects of earthquakes on existing unreinforced masonry bearing wall buildings.

The provisions of this chapter are intended as minimum standards for structural seismic resistance, and are established primarily to reduce the risk of life loss or injury. Compliance with these provisions will not necessarily prevent loss of life or injury, or prevent earthquake damage to retrofitted buildings.

SECTION A102 SCOPE

[BS] A102.1 General. The provisions of this chapter shall apply to all *existing buildings* not more than six stories in height above the base of the structure and having not fewer than one unreinforced masonry bearing wall. The elements regulated by this chapter shall be determined in accordance with Table A102.1. Except as provided herein, other structural provisions of the building code shall apply. This chapter does not apply to the *alteration* of existing electrical, plumbing, mechanical or fire safety systems.

[BS] A102.2 Essential and hazardous facilities. The provisions of this chapter shall not apply to the strengthening of buildings in *Risk Category* III or IV. Such buildings shall be strengthened to meet the requirements of the *International Building Code* for new buildings of the same *risk category* or other such criteria *approved by the code official*.

SECTION A103 DEFINITIONS

[BS] A103.1 Definitions. For the purpose of this chapter, the applicable definitions in the building code shall also apply.

[BS] BED JOINT. The horizontal layer of mortar on which a masonry unit is laid.

[BS] COLLAR JOINT. The vertical space between adjacent wythes. A collar joint may contain mortar or grout.

[BS] CROSSWALL. A new or existing wall that meets the requirements of Section A111.3. A crosswall is not a shear wall.

[BS] CROSSWALL SHEAR CAPACITY. The unit shear value times the length of the crosswall, $v_c L_c$.

[BS] DETAILED BUILDING SYSTEM ELEMENTS. The localized elements and the interconnections of these elements that define the design of the building.

[BS] DIAPHRAGM EDGE. The intersection of the horizontal diaphragm and a shear wall.

[BS] DIAPHRAGM SHEAR CAPACITY. The unit shear value times the depth of the diaphragm, $v_r D$.

[BS] FLEXIBLE DIAPHRAGM. A diaphragm of wood or untopped metal deck construction in which the horizontal deformation along its length is at least two times the average story drift.

HEAD JOINT. The vertical mortar joint placed between masonry units within the wythe.

[BS] NORMAL WALL. A wall perpendicular to the direction of seismic forces.

[BS] OPEN FRONT. An exterior building wall line on one side only without vertical elements of the seismic force-resisting system in one or more stories.

[BS] POINTING. The process of removal of deteriorated mortar from between masonry units and placement of new mortar. Also known as repointing or tuckpointing for purposes of this chapter.

[BS] REPOINTING. See “Pointing.”

[BS] RIGID DIAPHRAGM. A diaphragm of concrete construction or concrete-filled metal deck construction.

[BS] TUCKPOINTING. See “Pointing.”

[BS] UNREINFORCED MASONRY (URM). Includes burned clay, concrete or sand-lime brick; hollow clay or concrete block; plain concrete; and hollow clay tile. These materials shall comply with the requirements of Section A106 as applicable.

[BS] UNREINFORCED MASONRY BEARING WALL. A URM wall that provides the vertical support for the reaction of floor or roof-framing members for which the total

APPENDIX A

spacing of 24 inches (610 mm) with a maximum supported area of 4 square feet (0.372 m²).

Exception: Existing anchor ties for attaching brick veneer to brick backing shall be acceptable, provided that the ties are in good condition and conform to the following minimum size and material requirements.

Existing veneer anchor ties shall be considered adequate if they are of corrugated galvanized iron strips not less than 1 inch (25 mm) in width, 8 inches (203 mm) in length and 1/16 inch (1.6 mm) in thickness, or the equivalent.

2. The location and condition of existing veneer anchor ties shall be verified as follows:
 - 2.1. An *approved* testing laboratory shall verify the location and spacing of the ties and shall submit a report to the *code official* for approval as part of the structural analysis.
 - 2.2. The veneer in a selected area shall be removed to expose a representative sample of ties (not less than four) for inspection by the code official.

[BS] A113.8 Nonstructural masonry walls. Unreinforced masonry walls that do not carry design vertical or lateral loads and that are not required by the design to be part of the lateral force-resisting system shall be adequately anchored to new or existing supporting elements. The anchors and elements shall be designed for the out-of-plane forces specified in the building code. The height- or length-to-thickness ratio between such supporting elements for such walls shall not exceed nine.

[BS] A113.9 Truss and beam supports. Where trusses and beams other than rafters or joists are supported on masonry, independent secondary columns shall be installed to support vertical loads of the roof or floor members.

Exception: Secondary supports are not required where S_{D1} is less than 0.3 g.

[BS] A113.10 Adjacent buildings. Where elements of adjacent buildings do not have a separation of 5 inches (127 mm) or greater, the allowable height-to-thickness ratios for “all other buildings” per Table A110.2 shall be used in the direction of consideration.

**SECTION A114
WALLS OF UNBURNED CLAY,
ADOBE OR STONE MASONRY**

[BS] A114.1 General. Walls of unburned clay, adobe or stone masonry construction shall conform to the following:

1. Walls of unburned clay, adobe or stone masonry shall not exceed a height- or length-to-thickness ratio specified in Table A114.1.
2. Adobe shall be allowed a maximum value of 9 pounds per square inch (62.1 kPa) for shear unless higher values are justified by test.
3. Mortar for repointing may be of the same soil composition and stabilization as the brick, in lieu of cement mortar.

**[BS] TABLE A102.1
ELEMENTS REGULATED BY THIS CHAPTER**

BUILDING ELEMENTS	S_{D1}			
	$\geq 0.067_g < 0.133_g$	$\geq 0.133_g < 0.20_g$	$\geq 0.20_g < 0.30_g$	$> 0.30_g$
Parapets	X	X	X	X
Walls, anchorage	X	X	X	X
Walls, <i>h/t</i> ratios		X	X	X
Walls, in-plane shear		X	X	X
Diaphragms ^a			X	X
Diaphragms, shear transfer ^b		X	X	X
Diaphragms, demand-capacity ratios ^b			X	X

- a. Applies only to buildings designed according to the general procedures of Section A110.
- b. Applies only to buildings designed according to the special procedures of Section A111.

superimposed vertical load exceeds 100 pounds per linear foot (1459 N/m) of wall length.

[BS] UNREINFORCED MASONRY WALL. A masonry wall that relies on the tensile strength of masonry units, mortar and grout in resisting design loads, and in which the area of reinforcement is less than the minimum amounts as defined for reinforced masonry walls.

[BS] YIELD STORY DRIFT. The lateral displacement of one level relative to the level above or below at which yield stress is first developed in a frame member.

SECTION A104 SYMBOLS AND NOTATIONS

[BS] A104.1 Symbols and notations. For the purpose of this chapter, the following notations supplement the applicable symbols and notations in the building code.

- a_n = Diameter of core multiplied by its length or the area of the side of a square prism.
- A = Cross-sectional area of unreinforced masonry pier or wall, square inches (10^{-6} m²).
- A_b = Total area of the bed joints above and below the test specimen for each in-place shear test, square inches (10^{-6} m²).
- A_n = Area of net mortared or grouted section of a wall or wall pier.
- D = In-plane width dimension of pier, inches (10^{-3} m), or depth of diaphragm, feet (m).
- DCR = Demand-capacity ratio specified in Section A111.4.2.
- f'_m = Lower bound masonry compressive strength.
- f_{sp} = Tensile-splitting strength of masonry.
- F_{wx} = Force applied to a wall at level x , pounds (N).
- H = Least clear height of opening on either side of a pier, inches (10^{-3} m).
- h/t = Height-to-thickness ratio of URM wall. Height, h , is measured between wall anchorage levels and/or slab-on-grade.
- L = Span of diaphragm between shear walls, or span between shear wall and open front, feet (m).
- L_c = Length of crosswall, feet (m).
- L_i = Effective diaphragm span for an open-front building specified in Section A111.8, feet (m).
- P = Applied force as determined by standard test method of ASTM C496 or ASTM E519, pounds (N).
- P_D = Superimposed dead load at the location under consideration, pounds (N). For determination of the rocking shear capacity, dead load at the top of the pier under consideration shall be used.
- P_{D+L} = Stress resulting from the dead plus actual live load in place at the time of testing, pounds per square inch (kPa).
- P_{test} = Splitting tensile test load determined by standard test method ASTM C496, pounds (N).
- P_w = Weight of wall, pounds (N).
- R = Response modification factor for Ordinary plain masonry shear walls in Bearing Wall System from Table 12.2-1 of ASCE 7, where $R = 1.5$.
- S_{DS} = Design spectral acceleration at short period, in g units.
- S_{DI} = Design spectral acceleration at 1-second period, in g units.
- v_a = The shear strength of any URM pier, $v_m A / 1.5$ pounds (N).
- v_c = Unit shear strength for a crosswall sheathed with any of the materials given in Table A108.1(1) or A108.1(2), pounds per foot (N/m).
- v_{mL} = Shear strength of unreinforced masonry, pounds per square inch (kPa).
- V_{aa} = The shear strength of any URM pier or wall, pounds (N).
- V_{ca} = Total shear capacity of crosswalls in the direction of analysis immediately above the diaphragm level being investigated, $v_c L_c$, pounds (N).
- V_{cb} = Total shear capacity of crosswalls in the direction of analysis immediately below the diaphragm level being investigated, $v_c L_c$, pounds (N).
- V_p = Shear force assigned to a pier on the basis of its relative shear rigidity, pounds (N).
- V_r = Pier rocking shear capacity of any URM wall or wall pier, pounds (N).
- v_{test} = Load at incipient cracking for each in-place shear test performed in accordance with Section A106.3.3.1, pounds (N).
- v_{tl} = Lower bound mortar shear strength, pounds per square inch (kPa).
- v_{to} = Mortar shear test values as specified in Section A106.3.3.5, pounds per square inch (kPa).
- v_u = Unit shear capacity value for a diaphragm sheathed with any of the materials given in Table A108.1(1) or A108.1(2), pounds per foot (N/m).
- V_{wx} = Total shear force resisted by a shear wall at the level under consideration, pounds (N).
- W = Total seismic dead load as defined in the building code, pounds (N).
- W_d = Total dead load tributary to a diaphragm level, pounds (N).
- W_w = Total dead load of a URM wall above the level under consideration or above an open-front building, pounds (N).
- W_{wx} = Dead load of a URM wall assigned to level x halfway above and below the level under consideration, pounds (N).
- $\Sigma v_u D$ = Sum of diaphragm shear capacities of both ends of the diaphragm, pounds (N).

$\Sigma v_u D$ = For diaphragms coupled with crosswalls, $v_u D$ includes the sum of shear capacities of both ends of diaphragms coupled at and above the level under consideration, pounds (N).

ΣW_d = Total dead load of all the diaphragms at and above the level under consideration, pounds (N).

SECTION A105 GENERAL REQUIREMENTS

[BS] A105.1 General. The seismic force-resisting system specified in this chapter shall comply with the *International Building Code* and referenced standards, except as modified herein.

[BS] A105.2 Alterations and repairs. *Alterations* and *repairs* required to meet the provisions of this chapter shall comply with applicable structural requirements of the building code unless specifically provided for in this chapter.

[BS] A105.3 Requirements for plans. The following construction information shall be included in the plans required by this chapter:

1. Dimensioned floor and roof plans showing existing walls and the size and spacing of floor and roof-framing members and sheathing materials. The plans shall indicate all existing URM walls, and new crosswalls and shear walls, and their materials of construction. The location of these walls and their openings shall be fully dimensioned and drawn to scale on the plans.
2. Dimensioned URM wall elevations showing openings, piers, wall classes as defined in Section A106.2.3.8, thickness, heights, wall shear test locations, cracks or damaged portions requiring *repairs*, the general condition of the mortar joints, and if and where pointing is required. Where the exterior face is veneer, the type of veneer, its thickness and its bonding and/or ties to the structural wall masonry shall be noted.
3. The type of interior wall and ceiling materials, and framing.
4. The extent and type of existing wall anchorage to floors and roof where used in the design.
5. The extent and type of parapet corrections that were previously performed, if any.
6. *Repair* details, if any, of cracked or damaged unreinforced masonry walls required to resist forces specified in this chapter.
7. All other plans, sections and details necessary to delineate required retrofit construction.
8. The design procedure used shall be stated on both the plans and the permit application.
9. Details of the anchor prequalification program required by Section A107.5.3, if used, including location and results of all tests.
10. Quality assurance requirements of special inspection for all new construction materials and for retrofit construction including: anchor tests, pointing or repoint-

ing of mortar joints, installation of adhesive or mechanical anchors, and other elements as deemed necessary to ensure compliance with this chapter.

[BS] A105.4 Structural observation, testing and inspection. Structural observation, in accordance with Section 1704.5 of the *International Building Code*, shall be required for all structures in which seismic retrofit is being performed in accordance with this chapter. Structural observation shall include visual observation of work for compliance with the *approved* construction documents and confirmation of existing conditions assumed during design.

Structural testing and inspection for new and existing construction materials shall be in accordance with the building code, except as modified by this chapter.

Special inspection as described in Section A105.3, Item 10, shall be provided equivalent to Level 3 as prescribed in TMS 402, Table 3.1(2).

SECTION A106 MATERIALS REQUIREMENTS

[BS] A106.1 Condition of existing materials. Existing materials used as part of the required vertical load-carrying or seismic force-resisting system shall be evaluated by on-site investigation and: determined to be in good condition (free of degraded mortar, degraded masonry units or significant cracking); or shall be repaired, enhanced, retrofitted or removed and replaced with new materials. Mortar joint deterioration shall be patched by pointing or repointing of the eroded joint in accordance with Section A106.2.3.9. Existing significant cracks in solid unit unreinforced and solid grouted hollow unit masonry shall be repaired.

[BS] A106.2 Existing unreinforced masonry.

[BS] A106.2.1 General. Unreinforced masonry walls used to support vertical loads or seismic forces parallel and perpendicular to the wall plane shall be tested as specified in this section. Masonry that does not meet the minimum requirements established by this chapter shall be repaired, enhanced, removed and replaced with new materials, or alternatively, shall have its structural functions replaced with new materials and shall be anchored to supporting elements.

[BS] A106.2.2 Lay-up of walls. Unreinforced masonry walls shall be laid in a running bond pattern.

[BS] A106.2.2.1 Header in multiple-wythe solid brick. The facing and backing wythes of multiple-wythe walls shall be bonded so that not less than 10 percent of the exposed face area is composed of solid headers extending not less than 4 inches (102 mm) into the backing wythes. The clear distance between adjacent header courses shall not exceed 24 inches (610 mm) vertically or horizontally. Where backing consists of two or more wythes, the headers shall extend not less than 4 inches (102 mm) into the most distant wythe, or the backing wythes shall be bonded together with separate headers for which the area and spacing conform to the foregoing. Wythes of walls not meeting these requirements shall be considered to be veneer, and shall not be included in the effective thickness used in calcu-

lating the height-to-thickness ratio and the shear capacity strength of the wall.

Exception: Where SD1 is 0.3 g or less, veneer wythes anchored and made composite with backup masonry are permitted to be used for calculation of the effective thickness.

[BS] A106.2.2.2 Concrete masonry units and structural clay load-bearing tile. Grouted or ungrouted hollow concrete masonry units shall be tested in accordance with ASTM C140. Grouted or ungrouted structural clay load-bearing tile shall be tested in accordance with ASTM C34.

[BS] A106.2.2.3 Lay-up patterns. Lay-up patterns other than those specified in Section A106.2.2.1 are allowed if their performance can be justified.

[BS] A106.2.3 Testing of masonry.

[BS] A106.2.3.1 In-place mortar tests. Mortar shear test values, v_{io} , shall be obtained by one of the following:

1. ASTM C1531.
2. For masonry walls that have high shear strength mortar, or where in-place testing is not practical because of crushing or other failure mode of the masonry, alternative procedures for testing shall be used in accordance with Section A106.2.3.2.

[BS] A106.2.3.2 Alternative procedures for testing masonry. The tensile-splitting strength of existing masonry, f_{sp} , or the prism strength of existing masonry, f_m , is permitted to be determined in accordance with ASTM C496 and calculated by the following equation:

$$f_{sp} = \frac{0.494P}{a_n} \quad \text{(Equation A1-1)}$$

[BS] A106.2.3.3 Location of tests. The shear tests shall be taken at locations representative of the mortar conditions throughout the building. Test locations shall be determined at the building site by the *registered design professional* in charge. Results of all tests and their locations shall be recorded.

[BS] A106.2.3.4 Number of tests. The minimum number of tests per masonry class shall be determined as follows:

1. At each of both the first and top stories, not less than two tests per wall or line of wall elements providing a common line of resistance to seismic forces.
2. At each of all other stories, not less than one test per wall or line of wall elements providing a common line of resistance to seismic forces.
3. In any case, not less than one test per 1,500 square feet (139.4 m²) of wall surface and not less than a total of eight tests.

[BS] A106.2.3.5 Minimum quality of mortar.

1. Mortar shear test values, v_{io} , in pounds per square inch (kPa), shall be obtained for each in-place

shear test in accordance with the following equation:

$$v_{io} = (V_{test}/A_b) - P_{D+L} \quad \text{(Equation A1-2)}$$

where:

V_{test} = Load at first observed movement.

A_b = Total area of the bed joints above and below the test specimen.

P_{D+L} = Stress resulting from actual dead plus live loads in place at the time of testing.

2. Individual unreinforced masonry walls with more than 50 percent of mortar test values, v_{io} , less than 30 pounds per square inch (207 kPa) shall be pointed prior to and retested.
3. The lower bound mortar shear strength, v_{il} , is defined as the mean minus one standard deviation of the mortar shear test values, v_{io} .
4. Unreinforced masonry with mortar shear strength, v_{il} , less than 30 pounds per square inch (207 kPa) shall be pointed and retested or shall have its structural function replaced, and shall be anchored to supporting elements in accordance with Sections A106.2.1 and A113.8. When existing mortar in any wythe is pointed to increase its shear strength and is retested, the condition of the mortar in the adjacent bed joints of the inner wythe or wythes and the opposite outer wythe shall be examined for extent of deterioration. The shear strength of any wall class shall be not greater than that of the weakest wythe of that class.

[BS] A106.2.3.6 Minimum quality of masonry.

1. The minimum average value of tensile-splitting strength, f_{sp} , as calculated by Equation A1-1 shall be 50 pounds per square inch (344.7 kPa).
2. Individual unreinforced masonry walls with average tensile-splitting strength of less than 50 pounds per square inch (344.7 kPa) shall be pointed and retested.
3. The lower-bound mortar strength f_{spl} is defined as the mean minus one standard deviation P_{D+L} of the tensile-splitting test values f_{sp} .

[BS] A106.2.3.7 Collar joints. The collar joints shall be inspected at the test locations during each in-place shear test, and estimates of the percentage of surfaces of the adjacent wythe that are covered with mortar shall be reported along with the results of the in-place shear tests.

[BS] A106.2.3.8 Unreinforced masonry classes. Existing unreinforced masonry shall be categorized into one or more classes based on shear strength, quality of construction, state of *repair*, deterioration and weathering. A class shall be characterized by the masonry shear strength determined in accordance with Section A108.2. Classes are defined for whole walls, not for small areas of masonry within a wall. Discretion

in the definition of classes of masonry is permitted to avoid unnecessary testing.

[BS] A106.2.3.9 Pointing. Deteriorated mortar joints in unreinforced masonry walls shall be pointed in accordance with the following requirements:

1. **Joint preparation.** Deteriorated mortar shall be cut out by means of a toothing chisel or nonimpact power tool until sound mortar is reached, to a depth not less than $\frac{3}{4}$ inch (19.1 mm) or twice the thickness of the joint, whichever is less, but not greater than 2 inches (50 mm). Care shall be taken not to damage the masonry edges. After cutting is complete, all loose material shall be removed with a brush, or air or water stream.
2. **Mortar preparation.** The mortar mix shall be proportioned as required by the construction specifications and manufacturer's approved instructions.
3. **Packing.** The joint into which the mortar is to be packed shall be dampened but without free-standing water. The mortar shall be tightly packed into the joint in layers not exceeding $\frac{1}{4}$ inch (6.4 mm) deep until it is filled; then it shall be tooled to a smooth surface to match the original profile.

Nothing shall prevent pointing of any masonry wall joints before testing is performed in accordance with Section A106.2.3, except as required in Section A107.2.

SECTION A107 QUALITY CONTROL

[BS] A107.1 Pointing. Preparation and mortar pointing shall be performed with special inspection.

Exception: At the discretion of the *code official*, incidental pointing may be performed without special inspection.

[BS] A107.2 Masonry shear tests. In-place masonry shear tests shall comply with Section A106.2.3.1. Testing of masonry for determination of tensile-splitting strength shall comply with Section A106.2.3.2.

[BS] A107.3 Existing wall anchors. Existing wall anchors used as all or part of the required tension anchors shall be tested in pullout according to Section A107.5.1. Not fewer than four anchors tested per floor shall be tested in pullout, with not fewer than two tests at walls with joists framing into the wall and two tests at walls with joists parallel to the wall, but not less than 10 percent of the total number of existing tension anchors at each level.

[BS] A107.4 New wall anchors. New wall anchors embedded in URM walls shall be subject to special inspection prior to placement of the anchor and grout or adhesive in the drilled hole. Five percent of all anchors that do not extend through the wall shall be subject to a direct-tension test, and an additional 20 percent shall be tested using a calibrated torque wrench. Testing shall be performed in accordance with Section A107.5.

New wall anchors embedded in URM walls resisting tension forces or a combination of tension and shear forces shall

be subject to special inspection, prior to placement of the anchor and grout or adhesive in the drilled hole. Five percent of all anchors resisting tension forces shall be subject to a direct-tension test, and an additional 20 percent shall be tested using a calibrated torque wrench. Testing shall be performed in accordance with Section A107.5.

Exception: New bolts that extend through the wall with steel plates on the far side of the wall need not be tested.

[BS] A107.5 Tests of anchors in unreinforced masonry walls. Tests of anchors in unreinforced masonry walls shall be in accordance with Sections A107.5.1 through A107.5.3. Results of all tests shall be reported to the authority having jurisdiction. The report shall include the test results of maximum load for each test; pass-fail results; corresponding anchor size and type; orientation of loading; details of the anchor installation, testing apparatus and embedment; wall thickness; and joist orientation and proximity to the tested anchor.

[BS] A107.5.1 Direct tension testing of existing anchors and new anchors. The test apparatus shall be supported by the masonry wall. The test procedure for prequalification of tension and shear anchors shall comply with ASTM E488. Existing wall anchors shall be given a preload of 300 pounds (1335 N) before establishing a datum for recording elongation. The tension test load reported shall be recorded at $\frac{1}{8}$ inch (3.2 mm) relative movement between the existing anchor and the adjacent masonry surface. New embedded tension anchors shall be subject to a direct tension load of not less than 2.5 times the design load but not less than 1,500 pounds (6672 N) for five minutes.

Exception: Where obstructions occur, the distance between the anchor and the test apparatus support shall be not less than one-half the wall thickness for existing anchors and 75 percent of the embedment length for new embedded anchors.

[BS] A107.5.2 Torque testing of new anchors. Anchors embedded in unreinforced masonry walls shall be tested using a torque-calibrated wrench to the following minimum torques:

$\frac{1}{2}$ -inch-diameter (12.7 mm) bolts: 40 foot pounds (54.2 N-m).

$\frac{5}{8}$ -inch-diameter (15.9 mm) bolts: 50 foot pounds (67.8 N-m).

$\frac{3}{4}$ -inch-diameter (19.1 mm) bolts: 60 foot pounds (81.3 N-m).

[BS] A107.5.3 Prequalification test for bolts and other types of anchors. ASTM E488 or the test procedure in Section A107.5.1 is permitted to be used to determine tension or shear strength values for anchors greater than those permitted by Table A108.1(2). Anchors shall be installed in the same manner and using the same materials as will be used in the actual construction. Not fewer than five tests for each bolt size and type shall be performed for each class of masonry in which they are proposed to be used. The tension and shear strength values for such anchors shall be the lesser of the average ultimate load divided by 5.0 or the average load at which $\frac{1}{8}$ inch (3.2 mm) elongation occurs for each size and type of anchor and class of masonry.

SECTION A108 DESIGN STRENGTHS

[BS] A108.1 Strength values.

1. Strength values for existing materials are given in Table A108.1(1) and for new materials in Table A108.1(2).
2. The strength reduction factor, ϕ , shall be taken equal to 1.0.
3. The use of materials not specified herein shall be based on substantiating research data or engineering judgment, as *approved* by the *code official*.

[BS] A108.2 Masonry shear strength. The unreinforced masonry shear strength, v_{mL} , shall be determined for each masonry class from one of the following equations:

1. When testing is performed in accordance with Section A106.2.3.1, the unreinforced masonry shear strength, v_m , shall be determined by Equation A1-3.

$$v_{mL} = \frac{0.75 \left(0.75 v_{tL} \frac{P_D}{A_n} \right)}{1.5} \quad \text{(Equation A1-3)}$$

The mortar shear strength values, v_{tL} , shall be determined in accordance with Section A106.2.3.5.

2. When alternate testing is performed in accordance with Section A106.2.3.2, unreinforced masonry shear, v_{mL} , shall be determined by Equation A1-4.

$$v_{mL} = \frac{0.75 \left(f_{sp} + \frac{P_D}{A_n} \right)}{1.5} \quad \text{(Equation A1-4)}$$

[BS] A108.3 Masonry compression. Where any increase in wall dead plus live load compression stress occurs, the maximum compression stress in unreinforced masonry, Q_c/A_n , shall not exceed 300 pounds per square inch (2070 kPa).

[BS] A108.4 Masonry tension. Unreinforced masonry shall be assumed to have no tensile capacity.

[BS] A108.5 Wall tension anchors. The tension strength of wall anchors shall be the average of the tension test values for anchors having the same wall thickness and framing orientation.

[BS] A108.6 Foundations. For existing foundations, new total dead loads are permitted to be increased over the existing dead load by 25 percent. New total dead load plus live load plus seismic forces may be increased over the existing dead load plus live load by 50 percent. Higher values may be justified only in conjunction with a geotechnical investigation.

SECTION A109 ANALYSIS AND DESIGN PROCEDURE

[BS] A109.1 General. The elements of buildings hereby required to be analyzed are specified in Table A102.1.

[BS] A109.2 Selection of procedure. Buildings with rigid diaphragms shall be analyzed by the general procedure of Section A110. Buildings with flexible diaphragms shall be analyzed by

the general procedure or, where applicable, are permitted to be analyzed by the special procedure of Section A111.

SECTION A110 GENERAL PROCEDURE

[BS] A110.1 Minimum design lateral forces. Buildings shall be analyzed to resist minimum lateral forces assumed to act nonconcurrently in the direction of each of the main axes of the structure in accordance with the following:

$$V = \frac{0.75 S_{DS} W}{R} \quad \text{(Equation A1-5)}$$

[BS] A110.2 Seismic forces on elements of structures. Parts and portions of a structure not covered in Section A110.3 shall be analyzed and designed per the current building code, using force levels defined in Section A110.1.

Exceptions:

1. Unreinforced masonry walls for which height-to-thickness ratios do not exceed ratios set forth in Table A110.2 need not be analyzed for out-of-plane loading. Unreinforced masonry walls that exceed the allowable h/t ratios of Table A110.2 shall be braced according to Section A113.5.
2. Parapets complying with Section A113.6 need not be analyzed for out-of-plane loading.
3. Where walls are to be anchored to flexible floor and roof diaphragms, the anchorage shall be in accordance with Section A113.1.

[BS] A110.3 In-plane loading of URM shear walls and frames. Vertical seismic force-resisting elements shall be analyzed in accordance with Section A112.

[BS] A110.4 Redundancy and overstrength factors. Any redundancy or overstrength factors contained in the building code may be taken as unity. The vertical component of seismic force (E_v) may be taken as zero.

SECTION A111 SPECIAL PROCEDURE

[BS] A111.1 Limits for the application of this procedure. The special procedures of this section shall be applied only to buildings having the following characteristics:

1. Flexible diaphragms at all levels above the base of the structure.
2. Vertical elements of the seismic force-resisting system consisting predominantly of masonry or a combination of masonry and concrete shear walls.
3. Except for single-story buildings with an open front on one side only, not fewer than two lines of vertical elements of the seismic force-resisting system parallel to each axis of the building (see Section A111.8 for open-front buildings).

[BS] A111.2 Seismic forces on elements of structures. With the exception of the provisions in Sections A111.4 through A111.7, elements of structures shall comply with Sections A110.2 through A110.4.

[BS] TABLE A108.1(1)
STRENGTH VALUES FOR EXISTING MATERIALS

EXISTING MATERIALS OR CONFIGURATION OF MATERIALS ^a		STRENGTH VALUES
		x 14.594 for N/m
Horizontal diaphragms	Roofs with straight sheathing and roofing applied directly to the sheathing.	300 lbs. per ft. for seismic shear
	Roofs with diagonal sheathing and roofing applied directly to the sheathing.	750 lbs. per ft. for seismic shear
	Floors with straight tongue-and-groove sheathing.	300 lbs. per ft. for seismic shear
	Floors with straight sheathing and finished wood flooring with board edges offset or perpendicular.	1,500 lbs. per ft. for seismic shear
	Floors with diagonal sheathing and finished wood flooring.	1,800 lbs. per ft. for seismic shear
	Metal deck welded with minimal welding. ^c	1,800 lbs. per ft. for seismic shear
	Metal deck welded for seismic resistance. ^d	3,000 lbs. per ft. for seismic shear
Crosswalls ^b	Plaster on wood or metal lath.	600 lbs. per ft. for seismic shear
	Plaster on gypsum lath.	550 lbs. per ft. for seismic shear
	Gypsum wallboard, unblocked edges.	200 lbs. per ft. for seismic shear
	Gypsum wallboard, blocked edges.	400 lbs. per ft. for seismic shear
Existing footing, wood framing, structural steel, reinforcing steel	Plain concrete footings.	$f'_c = 1,500$ psi unless otherwise shown by tests
	Douglas fir wood.	Same as D.F. No. 1
	Reinforcing steel.	$F_y = 40,000$ psi maximum
	Structural steel.	$F_y = 33,000$ psi maximum

For SI: 1 inch = 25.4 mm, 1 square inch = 645.16 mm², 1 pound = 4.4 N, 1 pound per square inch = 6894.75 N/m², 1 pound per foot = 14.43 N/m.

a. Material must be sound and in good condition.

b. Shear values of these materials may be combined, except the total combined value should not exceed 900 pounds per foot.

c. Minimum 22-gage steel deck with welds to supports satisfying the standards of the Steel Deck Institute.

d. Minimum 22-gage steel deck with ³/₄-inch diameter plug welds at an average spacing not exceeding 8 inches and with sidelap welds appropriate for the deck span.

[BS] TABLE A108.1(2)
STRENGTH VALUES OF NEW MATERIALS USED IN CONJUNCTION WITH EXISTING CONSTRUCTION

NEW MATERIALS OR CONFIGURATION OF MATERIALS		STRENGTH VALUES
Horizontal diaphragms	Plywood sheathing applied directly over existing straight sheathing with ends of plywood sheets bearing on joists or rafters and edges of plywood located on center of individual sheathing boards.	675 lbs. per ft.
Crosswalls	Plywood sheathing applied directly over wood studs; no value should be given to plywood applied over existing plaster or wood sheathing.	1.2 times the value specified in the current building code.
	Drywall or plaster applied directly over wood studs.	The value specified in the current building code.
	Drywall or plaster applied to sheathing over existing wood studs.	50 percent of the value specified in the current building code.
Tension anchors ^f	Anchors extending entirely through unreinforced masonry wall secured with bearing plates on far side of a wall 30 square inches of area. ^{b, c}	5,400 lbs. per anchor for three-wythe minimum walls. 2,700 lbs. for two-wythe walls.
Shear bolts ^{e, f}	Anchors embedded not less than 8 inches into unreinforced masonry walls; anchors should be centered in 2 ¹ / ₂ -inch-diameter holes with dry-pack or nonshrink grout around the circumference of the anchor.	The value for plain masonry specified for solid masonry TMS 402; and no value larger than those given for 3/4-inch bolts should be used.
Combined tension and shear anchors ^f	Through-anchors—anchors meeting the requirements for shear and for tension anchors. ^{b, c}	Tension—same as for tension anchors. Shear—same as for shear anchors.
	Embedded anchors—anchors extending to the exterior face of the wall with a 2 ¹ / ₂ -inch round plate under the head and drilled at an angle of 22 ¹ / ₂ degrees to the horizontal; installed as specified for shear anchors. ^{a, b, c}	Tension—3,600 lbs. per anchor. Shear—same as for shear anchors.
Infilled walls	Reinforced masonry infilled openings in existing unreinforced masonry walls; provide keys or dowels to match reinforcing.	Same as values specified for unreinforced masonry walls.
Reinforced masonry ^d	Masonry piers and walls reinforced per the current building code.	The value specified in the current building code for strength design.
Reinforced concrete ^d	Concrete footings, walls and piers reinforced as specified in the current building code.	The value specified in the current building code for strength design.

For SI: 1 inch = 25.4 mm, 1 square inch = 645.16 mm², 1 pound = 4.4 N, 1 degree = 0.017 rad, 1 pound per foot = 14.43 N/m, 1 foot = 304.8 mm.

- a. Embedded anchors to be tested as specified in Section A107.4.
- b. Anchors shall be 1/2 inch minimum in diameter.
- c. Drilling for anchors shall be done with an electric rotary drill; impact tools should not be used for drilling holes or tightening anchors and shear bolt nuts.
- d. Load factors or capacity reduction factors shall not be used.
- e. Other bolt sizes, values and installation methods may be used, provided that a testing program is conducted in accordance with Section A107.5.3. The strength value shall be determined by multiplying the calculated allowable value, determined in accordance with Section A107.5.3, by 3.0, and the usable value shall be limited to not greater than 1.5 times the value given in the table. Bolt spacing shall not exceed 6 feet on center and shall be not less than 12 inches on center.
- f. An alternative adhesive anchor bolt system is permitted to be used providing: its properties and installation conform to an ICC Evaluation Service Report; and the report states that the system's use is in unreinforced masonry as an acceptable alternative to Sections A107.4 and A113.1 or TMS 402, Section 2.1.4. The report's allowable values shall be multiplied by a factor of three to obtain strength values and the strength reduction factor, ϕ , shall be taken equal to 1.0.

**[BS] TABLE A110.2
ALLOWABLE VALUE OF HEIGHT-TO-THICKNESS RATIO OF UNREINFORCED MASONRY WALLS**

WALL TYPES	$S_{D1} < 0.25g$		$S_{D1} \geq 0.4g$	
	$0.13g \leq S_{D1} < 0.25g$	$0.25g \leq S_{D1} < 0.4g$	BUILDINGS WITH CROSSWALLS ^a	ALL OTHER BUILDINGS
Walls of one-story buildings	20	16	16 ^{b,c}	13
First-story wall of multiple-story building	20	18	16	15
Walls in top story of multiple-story building	14	14	14 ^{b,c}	9
All other walls	20	16	16	13

For SI: 1 pound per square inch = 6894.75 N/m²

- Applies to the special procedures of Section A111 only. See Section A111.7 for other restrictions.
- This value of height-to-thickness ratio shall be used where mortar shear tests establish a tested mortar shear strength, v_r , of not less than 100 pounds per square inch. This value shall also be used where the tested mortar shear strength is not less than 60 pounds per square inch, and where a visual examination of the collar joint indicates not less than 50-percent mortar coverage.
- Where a visual examination of the collar joint indicates not less than 50-percent mortar coverage, and the tested mortar shear strength, v_r , is greater than 30 pounds per square inch but less than 60 pounds per square inch, the allowable height-to-thickness ratio may be determined by linear interpolation between the larger and smaller ratios in direct proportion to the tested mortar shear strength.

**[BS] TABLE A111.5
HORIZONTAL FORCE FACTOR, C_p**

CONFIGURATION OF MATERIALS	C_p
Roofs with straight or diagonal sheathing and roofing applied directly to the sheathing, or floors with straight tongue-and-groove sheathing.	0.50
Diaphragms with double or multiple layers of boards with edges offset, and blocked plywood systems.	0.75
Diaphragms of metal deck without topping: Minimal welding or mechanical attachment.	0.6
Welded or mechanically attached for seismic resistance.	0.68

**[BS] TABLE A113.6
MAXIMUM ALLOWABLE HEIGHT-TO-THICKNESS RATIO FOR PARAPETS**

	S_{D1}		
	$0.13g \leq S_{D1} < 0.25g$	$0.25g \leq S_{D1} < 0.4g$	$S_{D1} \geq 0.4g$
Maximum allowable height-to-thickness ratios	2.5	2.5	1.5

**[BS] TABLE A114.1
MAXIMUM HEIGHT-TO-THICKNESS RATIO FOR ADOBE OR STONE WALLS**

	S_{D1}		
	$0.13g \leq S_{D1} < 0.25g$	$0.25g \leq S_{D1} < 0.4g$	$S_{D1} \geq 0.4g$
One-story buildings	12	10	8
Two-story buildings			
First story	14	11	9
Second story	12	10	8

[BS] A111.3 Crosswalls. Crosswalls shall meet the requirements of this section.

[BS] A111.3.1 Crosswall definition. A crosswall is a wood-framed wall sheathed with any of the materials described in Table A108.1(1) or A108.1(2) or other system as defined in Section A111.3.5. Crosswalls shall be spaced not more than 40 feet (12 192 mm) on center measured perpendicular to the direction of consideration, and shall be placed in each story of the building. Crosswalls shall extend the full story height between diaphragms.

Exceptions:

1. Crosswalls need not be provided at all levels where used in accordance with Section A111.4.2, Item 4.
2. Existing crosswalls need not be continuous below a wood diaphragm at or within 4 feet (1219 mm) of grade, provided that:
 - 2.1. Shear connections and anchorage requirements of Section A111.5 are satisfied at all edges of the diaphragm.
 - 2.2. Crosswalls with total shear capacity of $0.5S_{D1}\Sigma W_d$ interconnect the diaphragm to the foundation.
 - 2.3. The demand-capacity ratio of the diaphragm between the crosswalls that are continuous to their foundations does not exceed 2.5, calculated as follows:

$$DCR = \frac{(2.1S_{D1}W_d + V_{ca})}{2v_u D}$$

(Equation A1-6)

[BS] A111.3.2 Crosswall shear capacity. Within any 40 feet (12 192 mm) measured along the span of the diaphragm, the sum of the crosswall shear capacities shall be not less than 30 percent of the diaphragm shear capacity of the strongest diaphragm at or above the level under consideration.

[BS] A111.3.3 Existing crosswalls. Existing crosswalls shall have a maximum height-to-length ratio between openings of 1.5 to 1. Existing crosswall connections to diaphragms need not be investigated as long as the crosswall extends to the framing of the diaphragms above and below.

[BS] A111.3.4 New crosswalls. New crosswall connections to the diaphragm shall develop the crosswall shear capacity. New crosswalls shall have the capacity to resist an overturning moment equal to the crosswall shear capacity times the story height. Crosswall overturning moments need not be cumulative over more than two stories.

[BS] A111.3.5 Other crosswall systems. Other systems, such as moment-resisting frames, may be used as crosswalls provided that the yield story drift does not exceed 1 inch (25 mm) in any story.

[BS] A111.4 Wood diaphragms.

[BS] A111.4.1 Acceptable diaphragm span. A diaphragm is acceptable if the point (L, DCR) on Figure A111.4.1 falls within Region 1, 2 or 3.

[BS] A111.4.2 Demand-capacity ratios. Demand-capacity ratios shall be calculated for the diaphragm at any level according to the following formulas:

1. For a diaphragm without qualifying crosswalls at levels immediately above or below:

$$DCR = 2.1S_{D1}W_d/\Sigma v_u D \quad \text{(Equation A1-7)}$$

2. For a diaphragm in a single-story building with qualifying crosswalls, or for a roof diaphragm coupled by crosswalls to the diaphragm directly below:

$$DCR = 2.1S_{D1}W_d/\Sigma v_u D + V_{cb} \quad \text{(Equation A1-8)}$$

3. For diaphragms in a multiple-story building with qualifying crosswalls in all levels:

$$DCR = 2.1S_{D1}\Sigma W_d/(\Sigma \Sigma v_u D + V_{cb}) \quad \text{(Equation A1-9)}$$

DCR shall be calculated at each level for the set of diaphragms at and above the level under consideration. In addition, the roof diaphragm shall meet the requirements of Equation A1-10.

4. For a roof diaphragm and the diaphragm directly below, if coupled by crosswalls:

$$DCR = 2.1S_{D1}\Sigma W_d/\Sigma \Sigma v_u D \quad \text{(Equation A1-10)}$$

[BS] A111.4.3 Chords. An analysis for diaphragm flexure need not be made, and chords need not be provided.

[BS] A111.4.4 Collectors. An analysis of diaphragm collector forces shall be made for the transfer of diaphragm edge shears into vertical elements of the lateral force-resisting system. Collector forces may be resisted by new or existing elements.

[BS] A111.4.5 Diaphragm openings.

1. Diaphragm forces at corners of openings shall be investigated and shall be developed into the diaphragm by new or existing materials.
2. In addition to the demand-capacity ratios of Section A111.4.2, the demand-capacity ratio of the portion of the diaphragm adjacent to an opening shall be calculated using the opening dimension as the span.
3. Where an opening occurs in the end quarter of the diaphragm span, the calculation of $v_u D$ for the demand-capacity ratio shall be based on the net depth of the diaphragm.

[BS] A111.5 Diaphragm shear transfer. Diaphragms shall be connected to shear walls and new vertical seismic force-resisting elements with connections capable of developing the diaphragm-loading tributary to the shear wall or new seismic force-resisting elements given by the lesser of the following formulas:

$$V = 1.2S_{D1}C_p W_d \quad \text{(Equation A1-11)}$$

using the C_p values in Table A111.5, or

$$V = v_u D \quad \text{(Equation A1-12)}$$

[BS] A111.6 Shear walls (In-plane loading).

[BS] A111.6.1 Wall story force. The wall story force distributed to a shear wall at any diaphragm level shall be the lesser value calculated as:

$$F_{wx} = 0.8S_{DI}(W_{wx} + W_d/2) \quad \text{(Equation A1-13)}$$

but need not exceed

$$F_{wx} = 0.8S_{DI}W_{wx} + v_u D \quad \text{(Equation A1-14)}$$

[BS] A111.6.2 Wall story shear. The wall story shear shall be the sum of the wall story forces at and above the level of consideration.

$$V_{wx} = \Sigma F_{wx} \quad \text{(Equation A1-15)}$$

[BS] A111.6.3 Shear wall analysis. Shear walls shall comply with Section A112.

[BS] A111.6.4 New seismic force-resisting elements. New seismic force-resisting elements such as moment frames, braced frames or shear walls shall be designed as required by the building code, except that the seismic forces shall be as specified in Section A111.6.1, and the story drift ratio shall be limited to 0.015, except as further limited by Section A112.4.2 for moment frames.

[BS] A111.7 Out-of-plane forces—unreinforced masonry walls.

[BS] A111.7.1 Allowable unreinforced masonry wall height-to-thickness ratios. The provisions of Section A110.2 are applicable, except the allowable height-to-thickness ratios given in Table A110.2 shall be determined from Figure A111.4.1 as follows:

1. In Region 1, height-to-thickness ratios for buildings with crosswalls may be used if qualifying crosswalls are present in all stories.
2. In Region 2, height-to-thickness ratios for buildings with crosswalls may be used whether or not qualifying crosswalls are present.
3. In Region 3, height-to-thickness ratios for “all other buildings” shall be used whether or not qualifying crosswalls are present.

[BS] A111.7.2 Walls with diaphragms in different regions. Where diaphragms above and below the wall under consideration have demand-capacity ratios in different regions of Figure A11.4.1, the lesser height-to-thickness ratio shall be used.

[BS] A111.8 Open-front design procedure. A single-story building with an open front on one side and crosswalls parallel to the open front may be designed by the following procedure:

1. Effective diaphragm span, L_p , for use in Figure A111.4.1 shall be determined in accordance with the following formula:

$$L_i = 2[(W_w/W_d)L + L] \quad \text{(Equation A1-16)}$$

2. Diaphragm demand-capacity ratio shall be calculated as:

$$DCR = 2.1S_{DI}(W_d + W_w)/[(v_u D) + V_{cb}] \quad \text{(Equation A1-17)}$$

**SECTION A112
ANALYSIS AND DESIGN**

[BS] A112.1 General. The following requirements are applicable to both the general procedure and the special procedure for analyzing vertical elements of the lateral force-resisting system.

[BS] A112.2 In-plane shear of unreinforced masonry walls.

[BS] A112.2.1 Flexural rigidity. Flexural components of deflection need not be considered in determining the rigidity of an unreinforced masonry wall.

[BS] A112.2.2 Shear walls with openings. Wall piers shall be analyzed according to the following procedure, which is diagrammed in Figure A112.2.2.

1. For any pier,
 - 1.1. The pier shear capacity shall be calculated as:

$$v_a = v_m A_n \quad \text{(Equation A1-18)}$$
 where:
 A_n = area of net mortared or grouted section of a wall or wall pier.
 - 1.2. The pier rocking shear capacity shall be calculated as:

$$V_r = 0.9P_D D/H \quad \text{(Equation A1-19)}$$

2. The wall piers at any level are acceptable if they comply with one of the following modes of behavior:

- 2.1. Rocking controlled mode. Where the pier rocking shear capacity is less than the pier shear capacity, in other words, $V_r < v_a$, for each pier in a level, forces in the wall at that level, V_{wx} , shall be distributed to each pier in proportion to $P_D D/H$.

For the wall at that level:

$$0.7V_{wx} < \Sigma V_r \quad \text{(Equation A1-20)}$$

- 2.2. Shear controlled mode. Where the pier shear capacity is less than the pier rocking capacity, in other words, $v_a < V_r$ in one or more pier(s) in a level, forces in the wall at the level, V_{wx} , shall be distributed to each pier in proportion to D/H .

For each pier at that level:

$$V_p < v_a \quad \text{(Equation A1-21)}$$

and

$$V_p < V_r \quad \text{(Equation A1-22)}$$

If $V_p < v_a$ for each pier and $V_p > V_r$ for one or more piers, such piers shall be omitted from the analysis, and the procedure shall be repeated for the remaining piers, unless the wall is strengthened and reanalyzed.

3. Masonry pier tension stress. Unreinforced masonry wall piers need not be analyzed for tension stress.

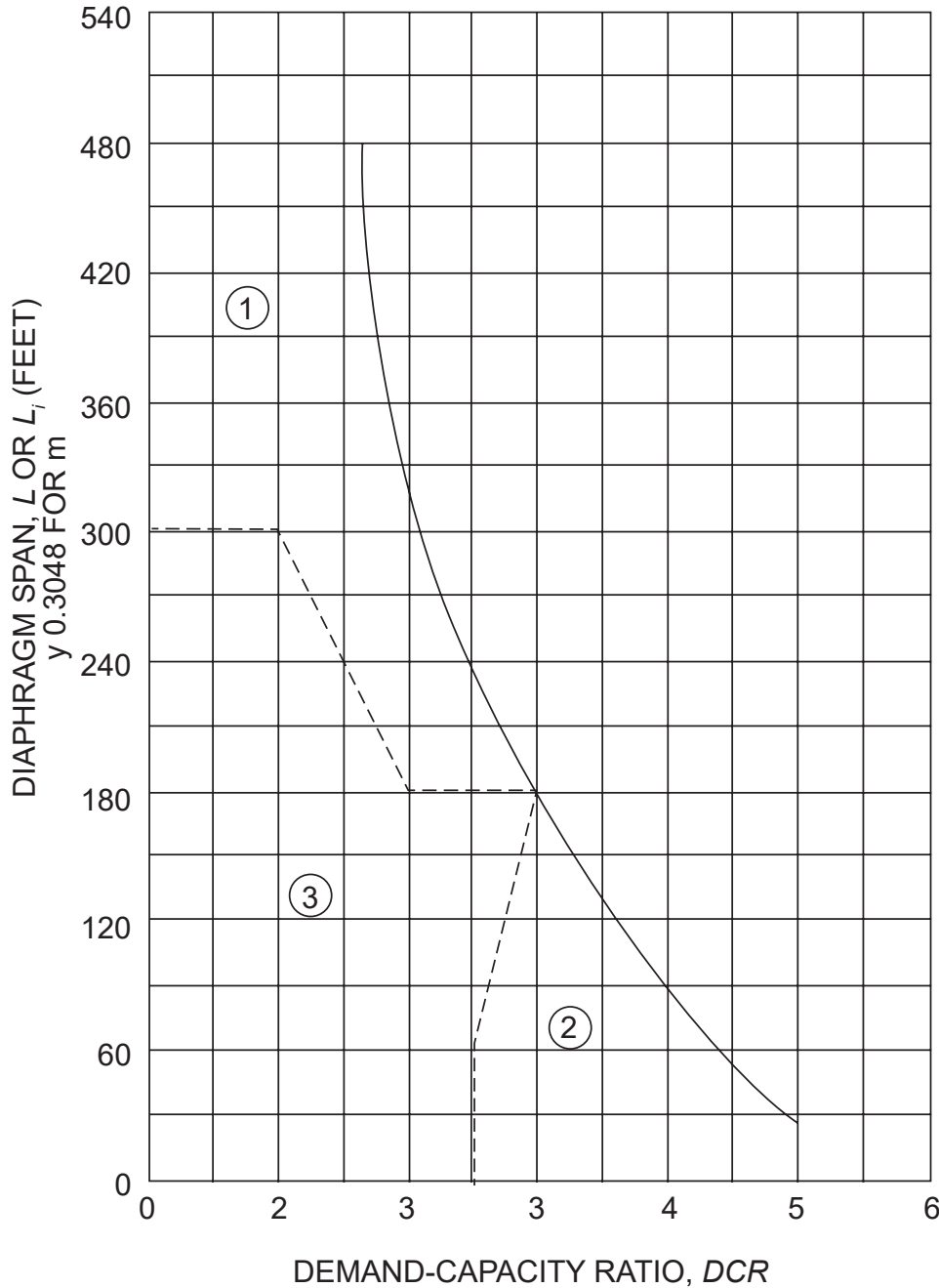

1. Region of demand-capacit ratios where crosswalls may be used to increase h/t ratios.
2. Region of demand-capacity ratios where h/t ratios of “buildings with crosswalls” may be used, whether or not crosswalls are present.
3. Region of demand-capacity ratios where h/t ratios of “all other buildings” shall be used, whether or not crosswalls are present.

For SI: 1 foot = 304.8 mm.

[BS] FIGURE A111.4.1
ACCEPTABLE DIAPHRAGM SPAN

[BS] A112.2.3 Shear walls without openings. Shear walls without openings shall be analyzed the same as for walls with openings, except that V_r shall be calculated as follows:

$$V_r = 0.9(P_D + 0.5P_w)D/H \quad \text{(Equation A1-23)}$$

[BS] A112.3 Plywood-sheathed shear walls. Plywood-sheathed shear walls may be used to resist lateral forces for URM buildings with flexible diaphragms analyzed according to provisions of Section A111. Plywood-sheathed shear walls shall not be used to share lateral forces with other materials along the same line of resistance.

[BS] A112.4 Combinations of vertical elements.

[BS] A112.4.1 Seismic force distribution. Seismic forces shall be distributed among the vertical-resisting elements in proportion to their relative rigidities, except that moment-resisting frames shall comply with Section A112.4.2.

[BS] A112.4.2 Moment-resisting frames. Moment-resisting frames shall not be used with an unreinforced masonry wall in a single line of resistance unless the wall has piers that have adequate shear capacity to sustain rocking in accordance with Section A112.2.2. The frames shall be designed in accordance with the building code to resist 100 percent of the seismic forces tributary to that line of resistance, as determined from Section A111.2. The story drift ratio shall be limited to 0.0075.

SECTION A113 DETAILED BUILDING SYSTEM DESIGN REQUIREMENTS

[BS] A113.1 Wall anchorage.

[BS] A113.1.1 Anchor locations. Unreinforced masonry walls shall be anchored at the roof and floor levels as required in Section A110.2. Ceilings of plaster or similar materials, where not attached directly to roof or floor framing and where abutting masonry walls, shall either be anchored to the walls at a maximum spacing of 6 feet (1829 mm), or be removed.

[BS] A113.1.2 Anchor requirements. Anchors shall consist of bolts installed through the wall as specified in Table A108.1(2), or an *approved* equivalent at a maximum anchor spacing of 6 feet (1829 mm). Wall anchors shall be secured to the framing members parallel or perpendicular to the wall to develop the required forces.

[BS] A113.1.3 Minimum wall anchorage. Anchorage of masonry walls to each floor or roof shall resist a minimum force determined as $0.9S_{DS}$ times the tributary weight or 200 pounds per linear foot (2920 N/m), whichever is greater, acting normal to the wall at the level of the floor or roof. Existing wall anchors, if used, must be tested and meet the requirements of Section A107.5.1 or be upgraded.

[BS] A113.1.4 Anchors at corners. At the roof and floor levels, both shear and tension anchors shall be provided within 2 feet (610 mm) horizontally from the inside of the corners of the walls.

[BS] A113.2 Diaphragm shear transfer. Anchors transmitting shear forces shall have a maximum spacing of 6 feet (1829 mm) and shall have nuts installed over malleable iron or plate washers where bearing on wood, and heavy-cut washers where bearing on steel.

[BS] A113.3 Collectors. Collector elements shall be provided that are capable of transferring the seismic forces originating in other portions of the building to the element providing the resistance to those forces.

[BS] A113.4 Ties and continuity. Ties and continuity shall conform to the requirements of the building code.

[BS] A113.5 Wall bracing.

[BS] A113.5.1 General. Where a wall height-to-thickness ratio exceeds the specified limits, the wall may be laterally supported by vertical bracing members per Section A113.5.2 or by reducing the wall height by bracing per Section A113.5.3.

[BS] A113.5.2 Vertical bracing members. Vertical bracing members shall be attached to floor and roof construction for their design loads independently of required wall anchors. Horizontal spacing of vertical bracing members shall not exceed one-half of the unsupported height of the wall or 10 feet (3048 mm). Deflection of such bracing members at design loads shall not exceed one-tenth of the wall thickness.

[BS] A113.5.3 Intermediate wall bracing. The wall height may be reduced by bracing elements connected to the floor or roof. Horizontal spacing of the bracing elements and wall anchors shall be as required by design, but shall not exceed 6 feet (1829 mm) on center. Bracing elements shall be detailed to minimize the horizontal displacement of the wall by the vertical displacement of the floor or roof.

[BS] A113.6 Parapets. Parapets and exterior wall appendages not conforming to this chapter shall be removed, or stabilized or braced to ensure that the parapets and appendages remain in their original positions.

The maximum height of an unbraced unreinforced masonry parapet above the lower of either the level of tension anchors or the roof sheathing shall not exceed the height-to-thickness ratio shown in Table A113.6. If the required parapet height exceeds this maximum height, a bracing system designed for the forces determined in accordance with the building code shall support the top of the parapet. Parapet corrective work must be performed in conjunction with the installation of tension roof anchors.

The height of a URM parapet above any wall anchor shall be not less than 12 inches (305 mm).

Exception: If a reinforced concrete beam is provided at the top of the wall, the height above the wall anchor is permitted to be not less than 6 inches (152 mm).

[BS] A113.7 Veneer.

1. Veneer shall be anchored with *approved* anchor ties conforming to the required design capacity specified in the building code and shall be placed at a maximum

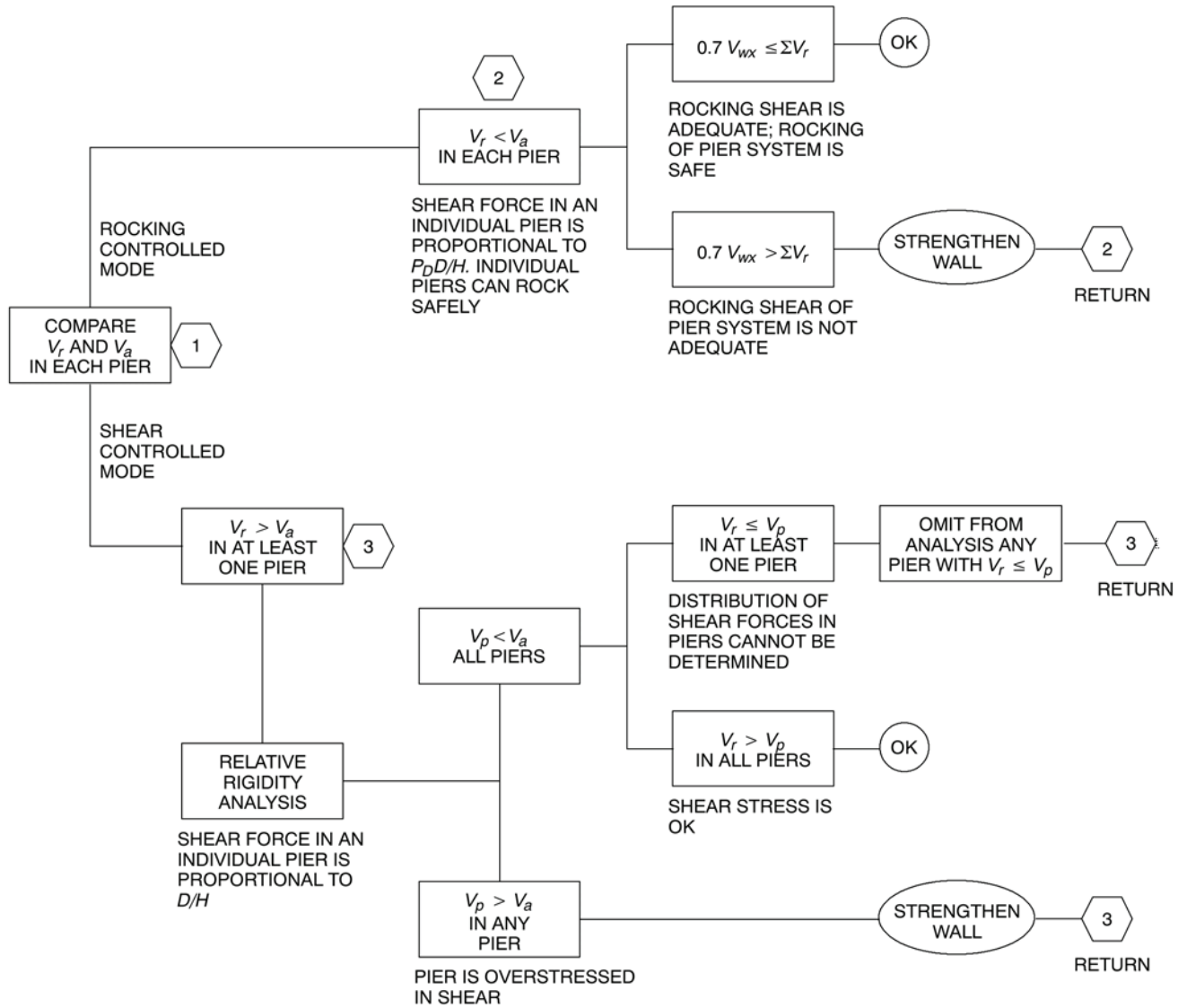

- V_a = Allowable shear strength of a pier.
- V_p = Shear force assigned to a pier on the basis of a relative shear rigidity analysis.
- V_r = Rocking shear capacity of pier.
- V_{wx} = Total shear force resisted by the wall.
- ΣV_r = Rocking shear capacity of all piers in the wall.

[BS] FIGURE A112.2.2
ANALYSIS OF URM WALL IN-PLANE SHEAR FORCES

CHAPTER A2

EARTHQUAKE HAZARD REDUCTION IN EXISTING REINFORCED CONCRETE AND REINFORCED MASONRY WALL BUILDINGS WITH FLEXIBLE DIAPHRAGMS

SECTION A201 PURPOSE

[BS] A201.1 Purpose. The purpose of this chapter is to promote public safety and welfare by reducing the risk of death or injury as a result of the effects of earthquakes on reinforced concrete and reinforced masonry wall buildings with flexible diaphragms. Based on past earthquakes, these buildings have been categorized as being potentially hazardous and prone to significant damage, including possible collapse in a moderate to major earthquake. The provisions of this chapter are minimum standards for structural seismic resistance established primarily to reduce the risk of life loss or injury on both subject and adjacent properties. These provisions will not necessarily prevent loss of life or injury, or prevent earthquake damage to an *existing building* that complies with these standards.

SECTION A202 SCOPE

[BS] A202.1 Scope. The provisions of this chapter shall apply to wall anchorage systems that resist out-of-plane forces and to collectors in existing reinforced concrete or reinforced masonry buildings with flexible diaphragms. Wall anchorage systems that were designed and constructed in accordance with the 1997 *Uniform Building Code*, 1999 *BOCA National Building Code*, 1999 *Standard Building Code* or the 2000 and subsequent editions of the *International Building Code* shall be deemed to comply with these provisions.

SECTION A203 DEFINITIONS

[BS] A203.1 Definitions. For the purpose of this chapter, the applicable definitions listed in Chapters 16, 19, 21, 22 and 23 of the *International Building Code* and the following shall apply:

[BS] FLEXIBLE DIAPHRAGMS. Roofs and floors including, but not limited to, those sheathed with plywood, wood decking (1-by or 2-by) or metal decks without concrete topping slabs.

SECTION A204 SYMBOLS AND NOTATIONS

[BS] A204.1 General. For the purpose of this chapter, the applicable symbols and notations in the *International Building Code* shall apply.

SECTION A205 GENERAL REQUIREMENTS

[BS] A205.1 General. The seismic-resisting elements specified in this chapter shall comply with provisions of Section 1613 of the *International Building Code*, except as modified herein.

[BS] A205.2 Alterations and repairs. *Alterations* and *repairs* required to meet the provisions of this chapter shall comply with applicable structural requirements of the building code unless specifically modified in this chapter.

[BS] A205.3 Requirements for plans. The plans shall accurately reflect the results of the engineering investigation and design and shall show all pertinent dimensions and sizes for plan review and construction. The following shall be provided:

1. Floor plans and roof plans shall show existing framing construction, diaphragm construction, proposed wall anchors, cross-ties and collectors. Existing nailing, anchors, cross-ties and collectors shall be shown on the plans if they are considered part of the lateral force-resisting systems.
2. At elevations where there are *alterations* or damage, details shall show roof and floor heights, dimensions of openings, location and extent of existing damage and proposed *repair*.
3. Typical wall panel details and sections with panel thickness, height, pilasters and location of anchors shall be provided.
4. Details shall include existing and new anchors and the method of developing anchor forces into the diaphragm framing, existing and new cross-ties, and existing and new or improved support of roof and floor girders at pilasters or walls.
5. The basis for design and the building code used for the design shall be stated on the plans.

[BS] A205.4 Structural observation, testing and inspection. Structural observation, in accordance with Section 1709 of the *International Building Code*, shall be required for all structures in which seismic retrofit is being performed in accordance with this chapter. Structural observation shall include visual observation of work for conformance to the *approved* construction documents and confirmation of existing conditions assumed during design.

Structural testing and inspection for new construction materials shall be in accordance with the building code, except as modified by this chapter.

SECTION A206 ANALYSIS AND DESIGN

[BS] A206.1 Reinforced concrete and reinforced masonry wall anchorage. Concrete and masonry walls shall be anchored to all floors and roofs that provide lateral support for the wall. The anchorage shall provide a positive direct connection between the wall and floor or roof construction capable of resisting 75 percent of the horizontal forces specified in Section 1613 of the *International Building Code*.

[BS] A206.2 Special requirements for wall anchorage systems. The steel elements of the wall anchorage system shall be designed in accordance with the *International Building Code* without the use of the 1.33 short duration allowable stress increase where using allowable stress design.

Wall anchors shall be provided to resist out-of-plane forces, independent of existing shear anchors.

Expansion anchors are only allowed with special inspection and *approved* testing for seismic loading.

Attaching the edge of plywood sheathing to steel ledgers is not considered compliant with the positive anchoring requirements of this chapter. Attaching the edge of steel decks to steel ledgers is not considered as providing the positive anchorage of this chapter unless testing or analysis is performed to establish shear values for the attachment perpendicular to the edge of the deck. Where steel decking is used as a wall anchor system, the existing connections shall be subject to field verification and the new connections shall be subject to special inspection.

Exception: Existing cast-in-place shear anchors are allowed to be used as wall anchors if the tie element can be readily attached to the anchors, and if the engineer or architect can establish tension values for the existing anchors through the use of *approved* as-built plans or testing and through analysis showing that the bolts are capable of resisting the total shear load (including dead load) while being acted on by the maximum tension force caused by an earthquake. Criteria for analysis and testing shall be determined by the building official.

[BS] A206.3 Development of anchor loads into the diaphragm. Development of anchor loads into roof and floor diaphragms shall comply with Section 1613 of the *International Building Code* using horizontal forces that are 75 percent of those used for new construction.

In wood diaphragms, anchorage shall not be accomplished by use of toenails or nails subject to withdrawal. Wood ledgers, top plates or framing shall not be used in cross-grain bending or cross-grain tension. The continuous ties required in Section 1613 of the *International Building Code* shall be in addition to the diaphragm sheathing.

Lengths of development of anchor loads in wood diaphragms shall be based on existing field nailing of the sheathing unless existing edge nailing is positively identified on the original construction plans or at the site.

Exception: If continuously tied girders are present, the maximum spacing of the continuity ties is the greater of the girder spacing or 24 feet (7315 mm).

[BS] A206.4 Anchorage at pilasters. Anchorage at pilasters shall be designed for the tributary wall-anchoring load per Section A206.1, considering the wall as a two-way slab. The edges of the two-way slab shall be considered to be fixed where there is continuity at pilasters and shall be considered to be pinned at roof and floor. The pilasters or the walls immediately adjacent to the pilasters shall be anchored directly to the roof framing such that the existing vertical anchor bolts at the top of the pilasters are bypassed without permitting tension or shear failure at the top of the pilasters.

The minimum anchorage force at a floor or roof between the pilasters shall be that specified in Section A206.1.

Exception: If existing vertical anchor bolts at the top of the pilasters are used for the anchorage, additional exterior confinement shall be provided as required to resist the total anchorage force.

[BS] A206.5 Symmetry. Symmetry of wall anchorage and continuity connectors about the minor axis of the framing member is required.

Exception: Eccentricity shall be allowed where it can be shown that all components of forces are positively resisted. The resistance must be supported by calculations or tests.

[BS] A206.6 Combination of anchor types. New anchors used in combination on a single framing member shall be of compatible behavior and stiffness.

[BS] A206.7 Anchorage at interior walls. Existing interior reinforced concrete or reinforced masonry walls that extend to the floor above or to the roof diaphragm shall be anchored for out-of-plane forces per Sections A206.1 and A206.3. Walls extending through the roof diaphragm shall be anchored for out-of-plane forces on both sides, and continuity ties shall be spliced across or continuous through the interior wall to provide diaphragm continuity.

[BS] A206.8 Collectors. If collectors are not present at reentrant corners or interior shear walls, they shall be provided. Existing or new collectors shall be designed for the capacity required to develop into the diaphragm a force equal to the lesser of the rocking or shear capacity of the reentrant wall or the tributary shear based on 75 percent of the horizontal forces specified in Chapter 16 of the *International Building Code*. The capacity of the collector need not exceed the capacity of the diaphragm to deliver loads to the collector. A connection shall be provided from the collector to the reentrant wall to transfer the full collector force (load). If a truss or beam other than a rafter or purlin is supported by the reentrant wall or by a column integral with the reentrant wall, then an independent secondary column is required to support the roof or floor members whenever rocking or shear capacity of the reentrant wall is less than the tributary shear.

[BS] A206.9 Mezzanines. Existing mezzanines relying on reinforced concrete or reinforced masonry walls for vertical or lateral support shall be anchored to the walls for the tributary mezzanine load. Walls depending on the mezzanine for

lateral support shall be anchored per Sections A206.1, A206.2 and A206.3.

Exception: Existing mezzanines that have independent lateral and vertical support need not be anchored to the walls.

SECTION A207 MATERIALS OF CONSTRUCTION

[BS] A207.1 Materials. Materials permitted by the building code, including their appropriate strength or allowable stresses, shall be used to meet the requirements of this chapter.

CHAPTER A3

PRESCRIPTIVE PROVISIONS FOR SEISMIC STRENGTHENING OF CRIPPLE WALLS AND SILL PLATE ANCHORAGE OF LIGHT, WOOD-FRAME RESIDENTIAL BUILDINGS

SECTION A301 GENERAL

[BS] A301.1 Purpose. The provisions of this chapter are intended to promote public safety and welfare by reducing the risk of earthquake-induced damage to existing wood-frame residential buildings. The requirements contained in this chapter are prescriptive minimum standards intended to improve the seismic performance of residential buildings; however, they will not necessarily prevent earthquake damage.

This chapter sets standards for strengthening that may be *approved* by the *code official* without requiring plans or calculations prepared by a registered design professional. The provisions of this chapter are not intended to prevent the use of any material or method of construction not prescribed herein. The *code official* may require that construction documents for strengthening using alternative materials or methods be prepared by a registered design professional.

[BS] A301.2 Scope. The provisions of this chapter apply to residential buildings of light-frame wood construction containing one or more of the structural weaknesses specified in Section A303.

Exception: The provisions of this chapter do not apply to the buildings, or elements thereof, listed as follows. These buildings or elements require analysis by a registered design professional in accordance with Section A301.3 to determine appropriate strengthening:

1. Group R-1.
2. Group R with more than four dwelling units.
3. Buildings with a lateral force-resisting system using poles or columns embedded in the ground.
4. Cripple walls that exceed 4 feet (1219 mm) in height.
5. Buildings exceeding three stories in height and any three-story building with cripple wall studs exceeding 14 inches (356 mm) in height.
6. Buildings where the *code official* determines that conditions exist that are beyond the scope of the prescriptive requirements of this chapter.
7. Buildings or portions thereof constructed on concrete slabs on grade.

[BS] A301.3 Alternative design procedures. The details and prescriptive provisions herein are not intended to be the only acceptable strengthening methods permitted. Alternative details and methods shall be permitted to be used where *approved* by the *code official*. Approval of alternatives shall be based on a demonstration that the method or material used is at least equivalent in terms of strength, deflection and capacity to that provided by the prescriptive methods and materials.

Where analysis by a registered design professional is required, such analysis shall be in accordance with all requirements of the building code, except that the seismic forces may be taken as 75 percent of those specified in the *International Building Code*.

SECTION A302 DEFINITIONS

[BS] A302.1 Definitions. For the purpose of this chapter, in addition to the applicable definitions in the building code, certain additional terms are defined as follows:

[BS] ADHESIVE ANCHOR. An assembly consisting of a threaded rod, washer, nut, and chemical adhesive *approved* by the *code official* for installation in existing concrete or masonry.

[BS] CRIPPLE WALL. A wood-frame stud wall extending from the top of the foundation to the underside of the lowest floor framing.

[BS] EXPANSION ANCHOR. An *approved* post-installed anchor, inserted into a predrilled hole in existing concrete or masonry, that transfers loads to or from the concrete or masonry by direct bearing or friction or both.

[BS] PERIMETER FOUNDATION. A foundation system that is located under the exterior walls of a building.

[BS] SNUG TIGHT. As tight as an individual can torque a nut on a bolt by hand, using a wrench with a 10-inch-long (254 mm) handle, and the point at which the full surface of the plate washer is contacting the wood member and slightly indenting the wood surface.

[BS] WOOD STRUCTURAL PANEL. A panel manufactured from veneers, wood strands or wafers or a combination of veneer and wood strands or wafers bonded together with waterproof synthetic resins or other suitable bonding systems. Examples of wood structural panels are:

Composite panels. A wood structural panel that is comprised of wood veneer and reconstituted wood-based material and bonded together with waterproof adhesive.

Oriented strand board (OSB). A mat-formed wood structural panel comprised of thin rectangular wood strands arranged in cross-aligned layers with surface layers normally arranged in the long panel direction and bonded with waterproof adhesive.

Plywood. A wood structural panel comprised of plies of wood veneer arranged in cross-aligned layers. The plies are bonded with waterproof adhesive that cures on application of heat and pressure.

SECTION A303 STRUCTURAL WEAKNESSES

[BS] A303.1 General. For the purposes of this chapter, any of the following conditions shall be deemed a structural weakness:

1. Sill plates or floor framing that are supported directly on the ground without a foundation system that conforms to the building code.
2. A perimeter foundation system that is constructed only of wood posts supported on isolated pad footings.
3. Perimeter foundation systems that are not continuous.

Exceptions:

1. Existing single-story exterior walls not exceeding 10 feet (3048 mm) in length, forming an extension of floor area beyond the line of an existing continuous perimeter foundation.
2. Porches, storage rooms and similar spaces not containing fuel-burning appliances.
4. A perimeter foundation system that is constructed of unreinforced masonry or stone.
5. Sill plates that are not connected to the foundation or that are connected with less than what is required by the building code.

Exception: Where *approved* by the *code official*, connections of a sill plate to the foundation made with other than sill bolts shall be accepted if the capacity of the connection is equivalent to that required by the building code.
6. Cripple walls that are not braced in accordance with the requirements of Section A304.4 and Table A304.3.1, or cripple walls not braced with diagonal sheathing or wood structural panels in accordance with the building code.

SECTION A304 STRENGTHENING REQUIREMENTS

[BS] A304.1 General.

[BS] A304.1.1 Scope. The structural weaknesses noted in Section A303 shall be strengthened in accordance with the requirements of this section. Strengthening work may include both new construction and *alteration* of existing construction. Except as provided herein, all strengthening work and materials shall comply with the applicable provisions of the *International Building Code*.

[BS] A304.1.2 Condition of existing wood materials. Existing wood materials that will be a part of the strengthening work (such as sills, studs and sheathing) shall be in a sound condition and free from defects that substantially reduce the capacity of the member. Any wood material found to contain fungus infection shall be removed and replaced with new material. Any wood material found to be infested with insects or to have been infested with insects shall be strengthened or replaced with new materi-

als to provide a net dimension of sound wood equal to or greater than its undamaged original dimension.

[BS] A304.1.3 Floor joists not parallel to foundations. Floor joists framed perpendicular or at an angle to perimeter foundations shall be restrained either by an existing nominal 2-inch-wide (51 mm) continuous rim joist or by a nominal 2-inch-wide (51 mm) full-depth block between alternate joists in one- and two-story buildings, and between each joist in three-story buildings. Existing blocking for multiple-story buildings must occur at each joist space above a braced cripple wall panel.

Existing connections at the top and bottom edges of an existing rim joist or blocking need not be verified in one-story buildings. In multiple-story buildings, the existing top edge connection need not be verified; however, the bottom edge connection to either the foundation sill plate or the top plate of a cripple wall shall be verified. The minimum existing bottom edge connection shall consist of 8d toenails spaced 6 inches (152 mm) apart for a continuous rim joist, or three 8d toenails per block. Where this minimum bottom edge-connection is not present or cannot be verified, a supplemental connection installed as shown in Figure A304.1.3 or A304.1.4(2) shall be provided.

Where an existing continuous rim joist or the minimum existing blocking does not occur, new $\frac{3}{4}$ -inch (19.1 mm) or $\frac{23}{32}$ -inch (18 mm) wood structural panel blocking installed tightly between floor joists and nailed as shown in Figure A304.1.4(3) shall be provided at the inside face of the cripple wall. In lieu of wood structural panel blocking, tight fitting, full-depth 2-inch (51 mm) blocking may be used. New blocking may be omitted where it will interfere with vents or plumbing that penetrates the wall.

[BS] A304.1.4 Floor joists parallel to foundations. Where existing floor joists are parallel to the perimeter foundations, the end joist shall be located over the foundation and, except for required ventilation openings, shall be continuous and in continuous contact with the foundation sill plate or the top plate of the cripple wall. Existing connections at the top and bottom edges of the end joist need not be verified in one-story buildings. In multiple-story buildings, the existing top edge connection of the end joist need not be verified; however, the bottom edge connection to either the foundation sill plate or the top plate of a cripple wall shall be verified. The minimum bottom edge connection shall be 8d toenails spaced 6 inches (152 mm) apart. If this minimum bottom edge connection is not present or cannot be verified, a supplemental connection installed as shown in Figure A304.1.4(1), A304.1.4(2) or A304.1.4(3) shall be provided.

[BS] A304.2 Foundations.

[BS] A304.2.1 New perimeter foundations. New perimeter foundations shall be provided for structures with the structural weaknesses noted in Items 1 and 2 of Section A303. Soil investigations or geotechnical studies are not required for this work unless the building is located in a special study zone as designated by the *code official* or other authority having jurisdiction.

**[BS] TABLE A304.3.1
SILL PLATE ANCHORAGE AND CRIPPLE WALL BRACING**

NUMBER OF STORIES ABOVE CRIPPLE WALLS	MINIMUM SILL PLATE CONNECTION AND MAXIMUM SPACING ^{a, b, c}	AMOUNT OF BRACING FOR EACH WALL LINE ^{d, e, f}	
		A Combination of Exterior Walls Finished with Portland Cement Plaster and Roofing Using Clay Tile or Concrete Tile Weighing More than 6 psf (287 N/m ²)	All Other Conditions
One story	$\frac{1}{2}$ inch spaced 6 feet, 0 inch center-to-center with washer plate	Each end and not less than 50 percent of the wall length	Each end and not less than 40 percent of the wall length
Two stories	$\frac{1}{2}$ inch spaced 4 feet, 0 inch center-to-center with washer plate; or $\frac{5}{8}$ inch spaced 6 feet, 0 inch center-to-center with washer plate	Each end and not less than 70 percent of the wall length	Each end and not less than 50 percent of the wall length
Three stories	$\frac{5}{8}$ inch spaced 4 feet, 0 inch center-to-center with washer plate	100 percent of the wall length ^g	Each end and not less than 80 percent of the wall length ^g

For SI: 1 inch = 25.4 mm, 1 foot = 304.8 mm, 1 pound per square foot = 47.88 N/m².

- Sill plate anchors shall be adhesive anchors or expansion anchors in accordance with Section A304.3.1.
- All washer plates shall be 3 inches by 3 inches by 0.229 inch minimum. The hole in the plate washer is permitted to be diagonally slotted with a width of up to $\frac{3}{16}$ inch larger than the bolt diameter and a slot length not to exceed $1\frac{3}{4}$ inches, provided that a standard cut washer is placed between the plate washer and the nut.
- This table shall also be permitted for the spacing of the alternative connections specified in Section A304.3.1.
- See Figure A304.4.2 for braced panel layout.
- Braced panels at ends of walls shall be located as near to the end as possible.
- All panels along a wall shall be nearly equal in length and shall be nearly equal in spacing along the length of the wall.
- The minimum required underfloor ventilation openings are permitted in accordance with Section A304.4.4.

**[BS] TABLE A304.3.2
SILL PLATE ANCHORAGE FOR VARIOUS LENGTHS OF SILL PLATE^{a, b}**

NUMBER OF STORIES	LENGTHS OF SILL PLATE		
	Less than 12 feet to 6 feet	Less than 6 feet to 30 inches	Less than 30 inches ^c
One story	Three connections	Two connections	One connection
Two stories	Four connections for $\frac{1}{2}$ -inch anchors or bolts or three connections for $\frac{5}{8}$ -inch anchors or bolts	Two connections	One connection
Three stories	Four connections	Two connections	One connection

For SI: 1 inch = 25.4 mm, 1 foot = 304.8 mm.

- Connections shall be either adhesive anchors or expansion anchors.
- See Section A304.3.2 for minimum end distances.
- Connections shall be placed as near to the center of the length of plate as possible.

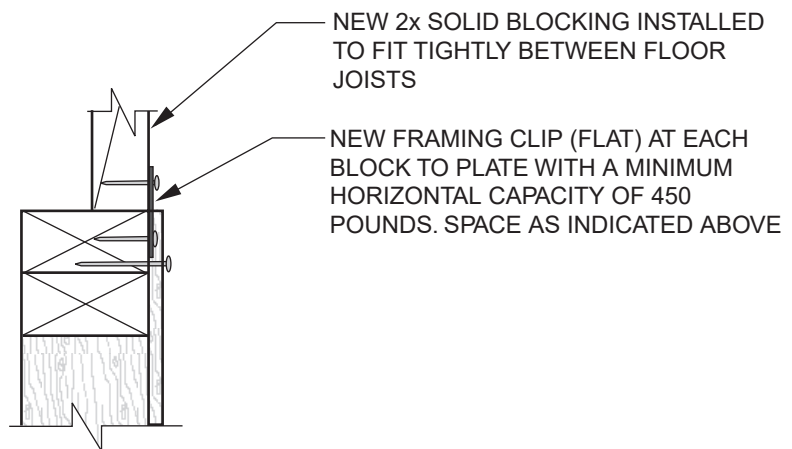
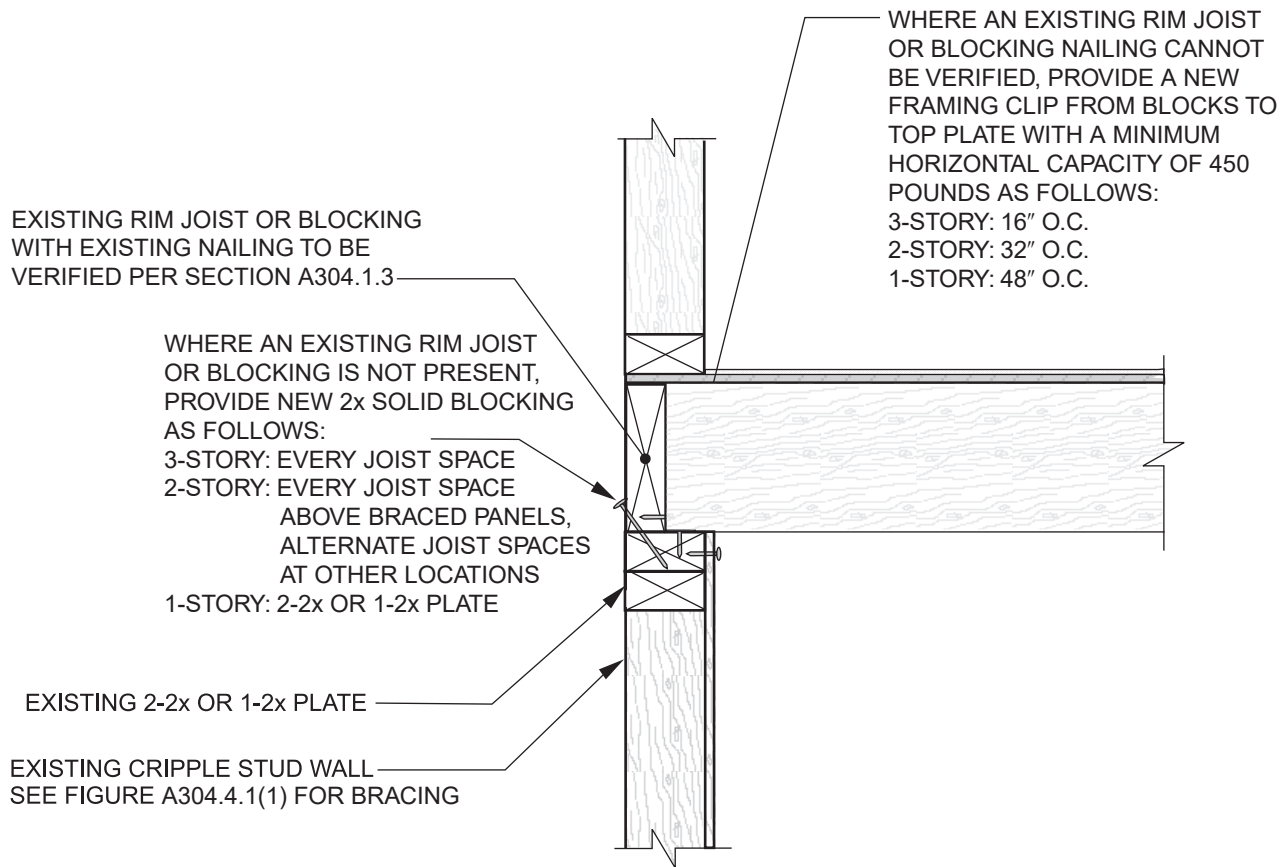

ALTERNATE CONNECTION FOR FLUSH CONNECTION

For SI: 1 inch = 25.4 mm, 1 pound = 4.4 N.

NOTE: See manufacturing instructions for nail sizes associated with metal framing clips.

**[BS] FIGURE A304.1.3
 TYPICAL FLOOR TO CRIPPLE WALL CONNECTION (FLOOR JOISTS NOT PARALLEL TO FOUNDATIONS)**

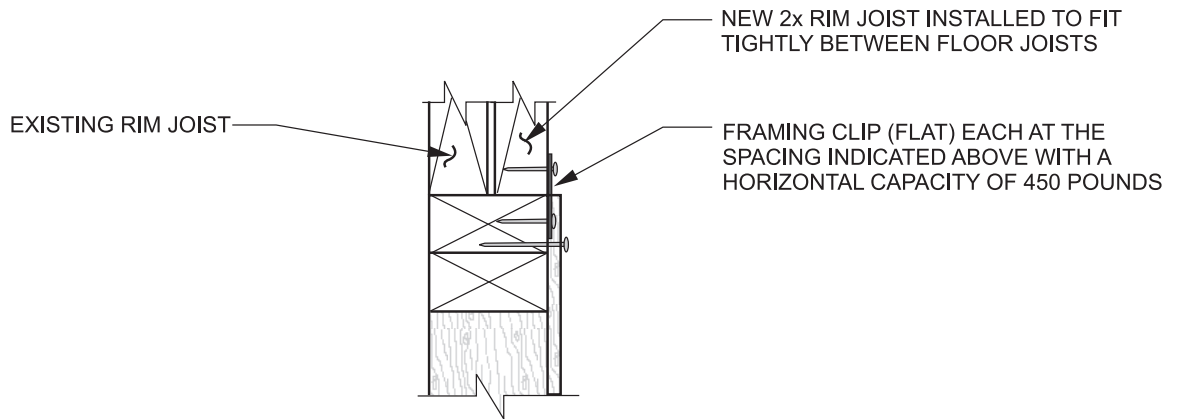
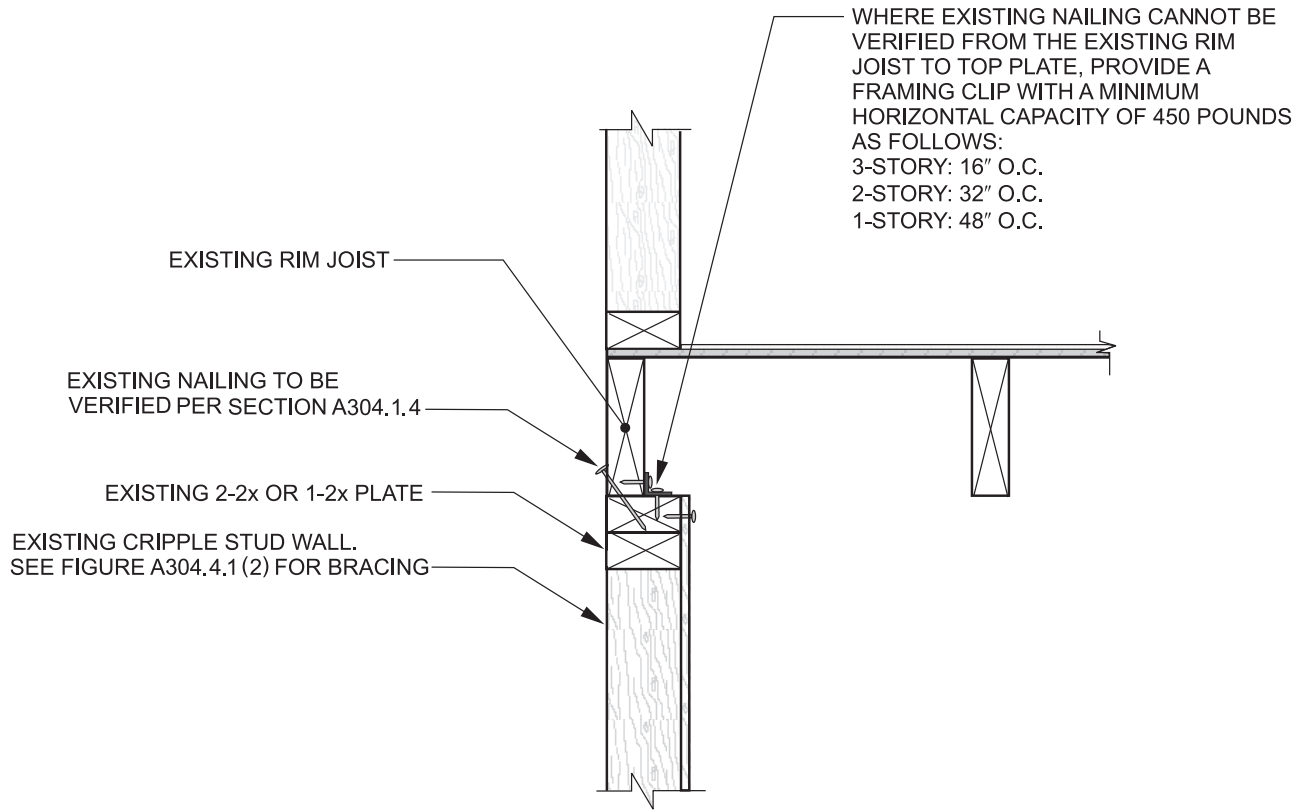

ALTERNATIVE CONNECTION FOR FLUSH CONNECTION

For SI: 1 inch = 25.4 mm, 1 pound = 4.4 N.

NOTE: See manufacturing instructions for nail sizes associated with metal framing clips.

**[BS] FIGURE A304.1.4(1)
TYPICAL FLOOR TO CRIPPLE WALL CONNECTION (FLOOR JOISTS PARALLEL TO FOUNDATIONS)**

APPENDIX A

WHERE AN EXISTING RIM JOIST OR BLOCKING IS NOT PRESENT, PROVIDE NEW 2x SOLID BLOCKING AS FOLLOWS:
 3-STORY: EVERY JOIST SPACE
 2-STORY: EVERY JOIST SPACE ABOVE BRACED PANELS, ALTERNATE JOIST SPACES AT OTHER LOCATIONS
 1-STORY: ALTERNATE JOIST SPACES

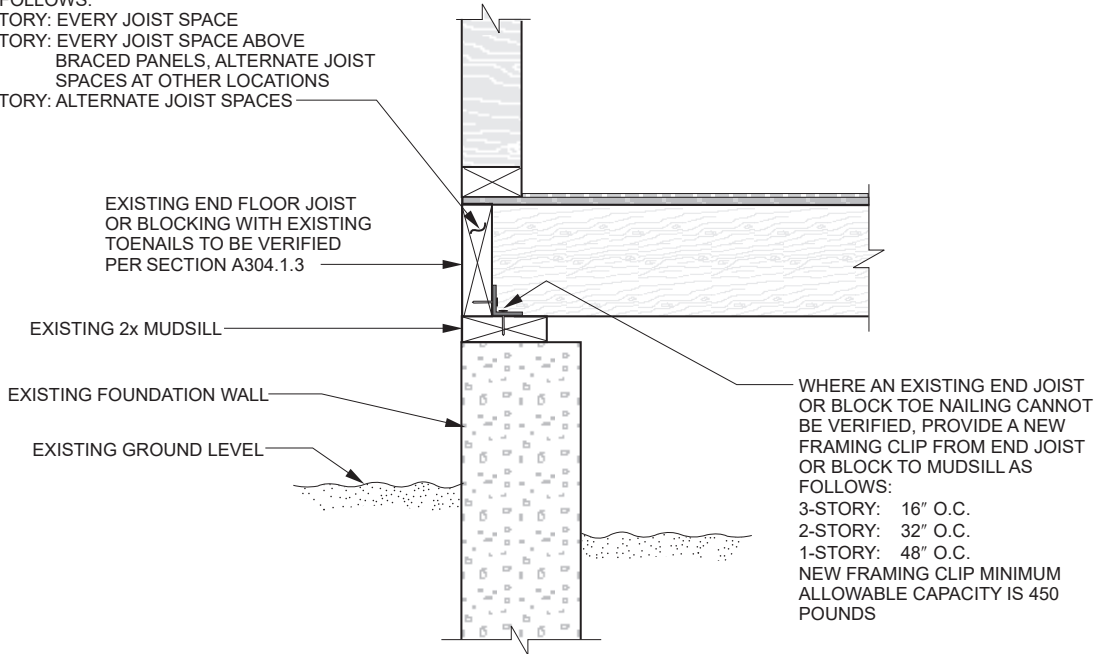

FLOOR JOISTS NOT PARALLEL TO FOUNDATIONS

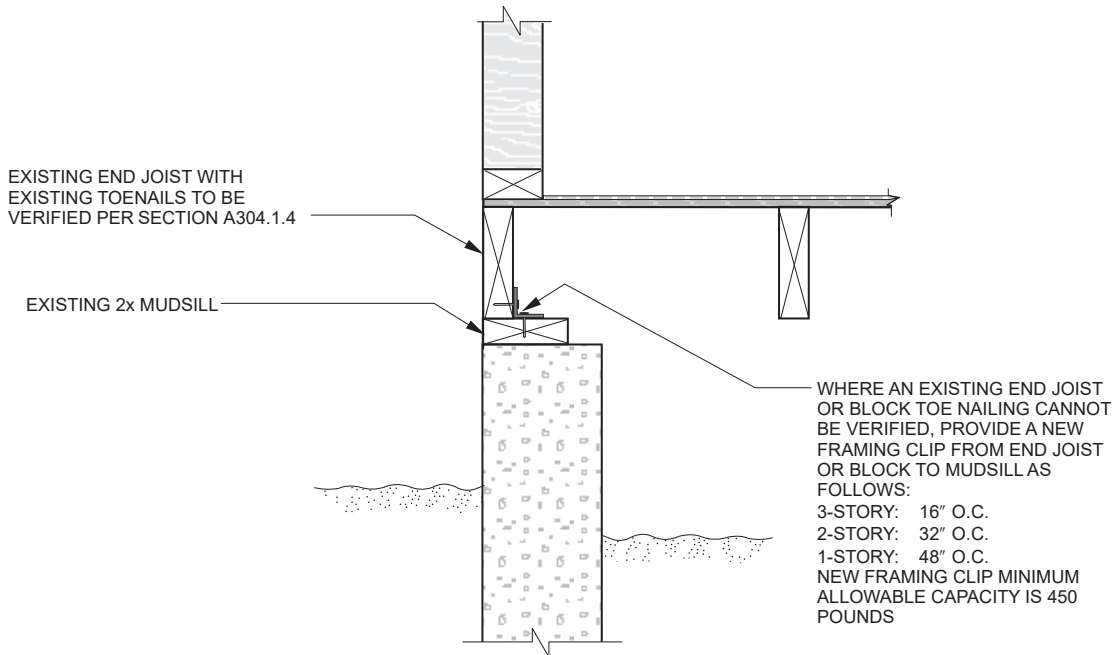

FLOOR JOISTS PARALLEL TO FOUNDATIONS

For SI: 1 inch = 25.4 mm.

NOTES:

1. See Section A304.3 for sill plate anchorage.
2. See manufacturing instructions for nail sizes associated with metal framing clips.

**[BS] FIGURE A304.1.4(2)
 TYPICAL FLOOR TO MUDSILL CONNECTIONS**

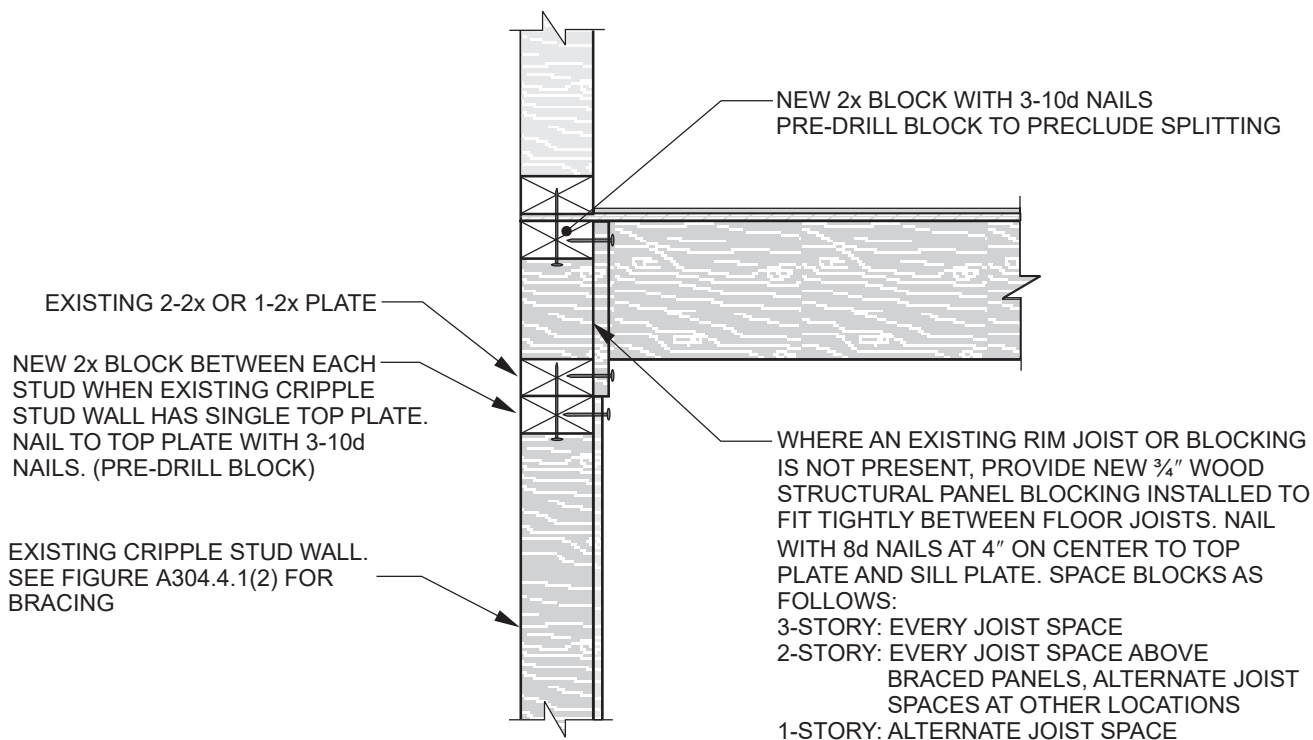

FLOOR JOISTS NOT PARALLEL TO FOUNDATION

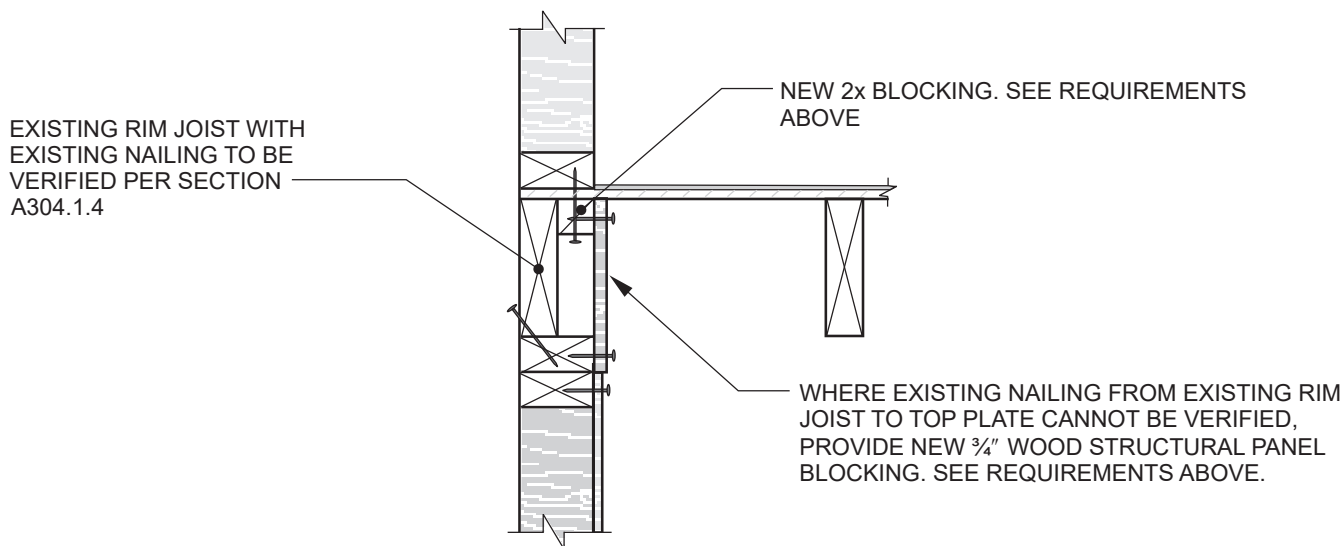

FLOOR JOISTS PARALLEL TO FOUNDATION

For SI: 1 inch = 25.4 mm, 1 pound = 4.4 N.
NOTE: See Section A304.4 for cripple wall bracing.

**[BS] FIGURE A304.1.4(3)
 ALTERNATIVE FLOOR FRAMING TO CRIPPLE WALL CONNECTION**

APPENDIX A

NUMBER OF STORIES	MINIMUM FOUNDATION DIMENSIONS					MINIMUM FOUNDATION REINFORCING	
	W	F	D ^{a, b, c}	T	H	VERTICAL REINFORCING	
						Single-pour wall and footing	Footing placed separate from wall
1	12 inches	6 inches	12 inches	6 inches	≤ 24 inches	#4 @ 48 inches on center	#4 @ 32 inches on center
2	15 inches	7 inches	18 inches	8 inches	≥ 36 inches	#4 @ 48 inches on center	#4 @ 32 inches on center
3	18 inches	8 inches	24 inches	10 inches	≥ 36 inches	#4 @ 48 inches on center	#4 @ 18 inches on center

For SI: 1 inch = 25.4 mm.

- a. Where frost conditions occur, the minimum depth shall extend below the frost line.
- b. The ground surface along the interior side of the foundation may be excavated to the elevation of the top of the footing.
- c. Where the soil is designated as expansive, the foundation depth and reinforcement shall be approved by the code official.

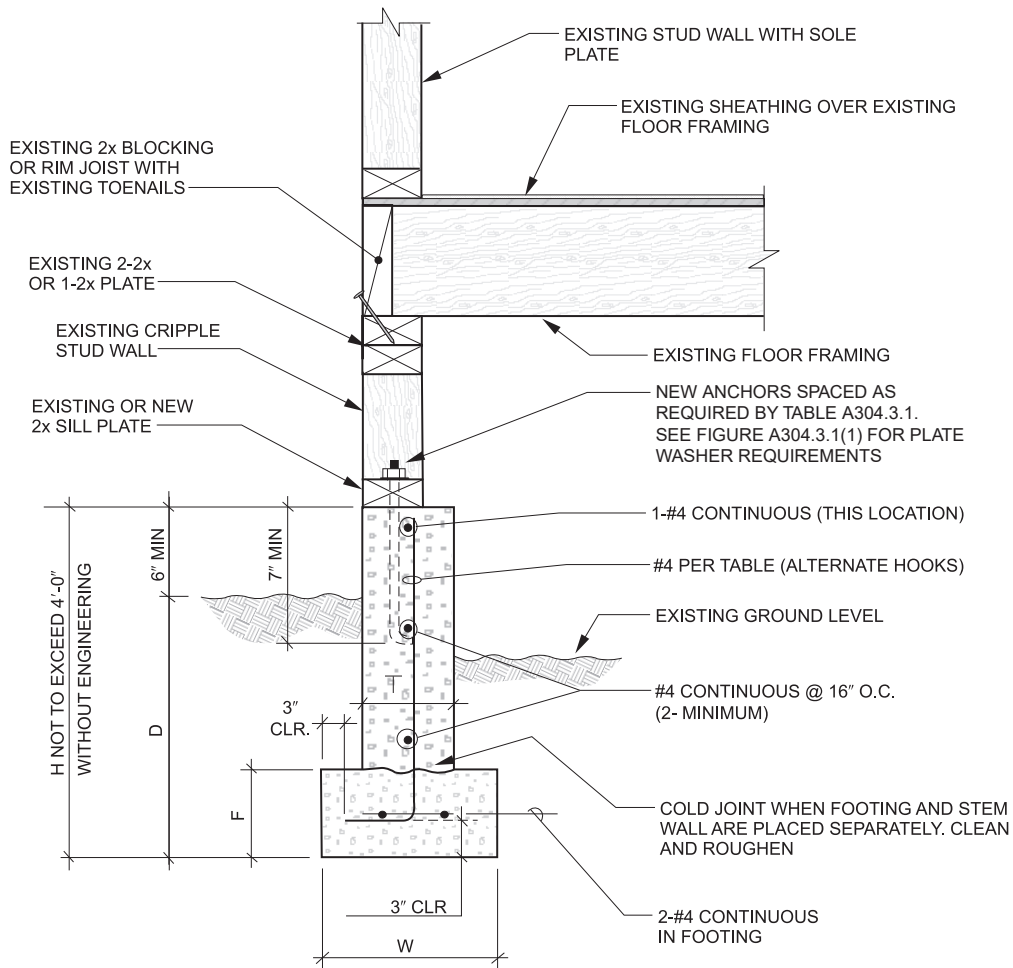

For SI: 1 inch = 25.4 mm, 1 foot = 304.8 mm.

[BS] FIGURE A304.2.3(1)
NEW REINFORCED CONCRETE FOUNDATION SYSTEM

MINIMUM FOUNDATION DIMENSIONS					MINIMUM FOUNDATION REINFORCING		
NUMBER OF STORIES	W	F	D ^{a, b, c}	T	H	VERTICAL REINFORCING	HORIZONTAL REINFORCING
1	12 inches	6 inches	12 inches	6 inches	≤ 24 inches	#4 @ 24 inches on center	#4 continuous at top of stem wall
2	15 inches	7 inches	18 inches	8 inches	≥ 24 inches	#4 @ 24 inches on center	#4 @ 16 inches on center
3	18 inches	8 inches	24 inches	10 inches	≥ 36 inches	#4 @ 24 inches on center	#4 @ 16 inches on center

For SI: 1 inch = 25.4 mm.

- a. Where frost conditions occur, the minimum depth shall extend below the frost line.
- b. The ground surface along the interior side of the foundation may be excavated to the elevation of the top of the footing.
- c. Where the soil is designated as expansive, the foundation depth and reinforcement shall be approved by the code official.

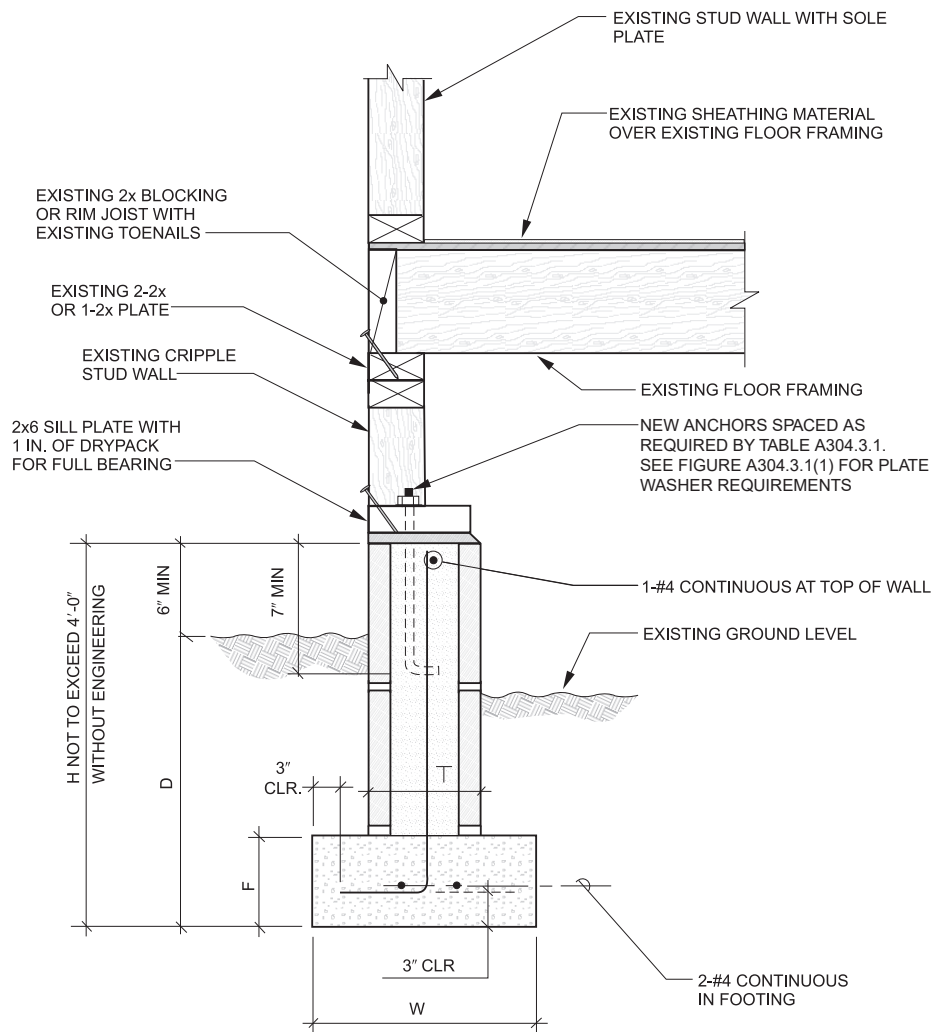

For SI: 1 inch = 25.4 mm, 1 foot = 304.8 mm.

[BS] FIGURE A304.2.3(2)
NEW MASONRY CONCRETE FOUNDATION

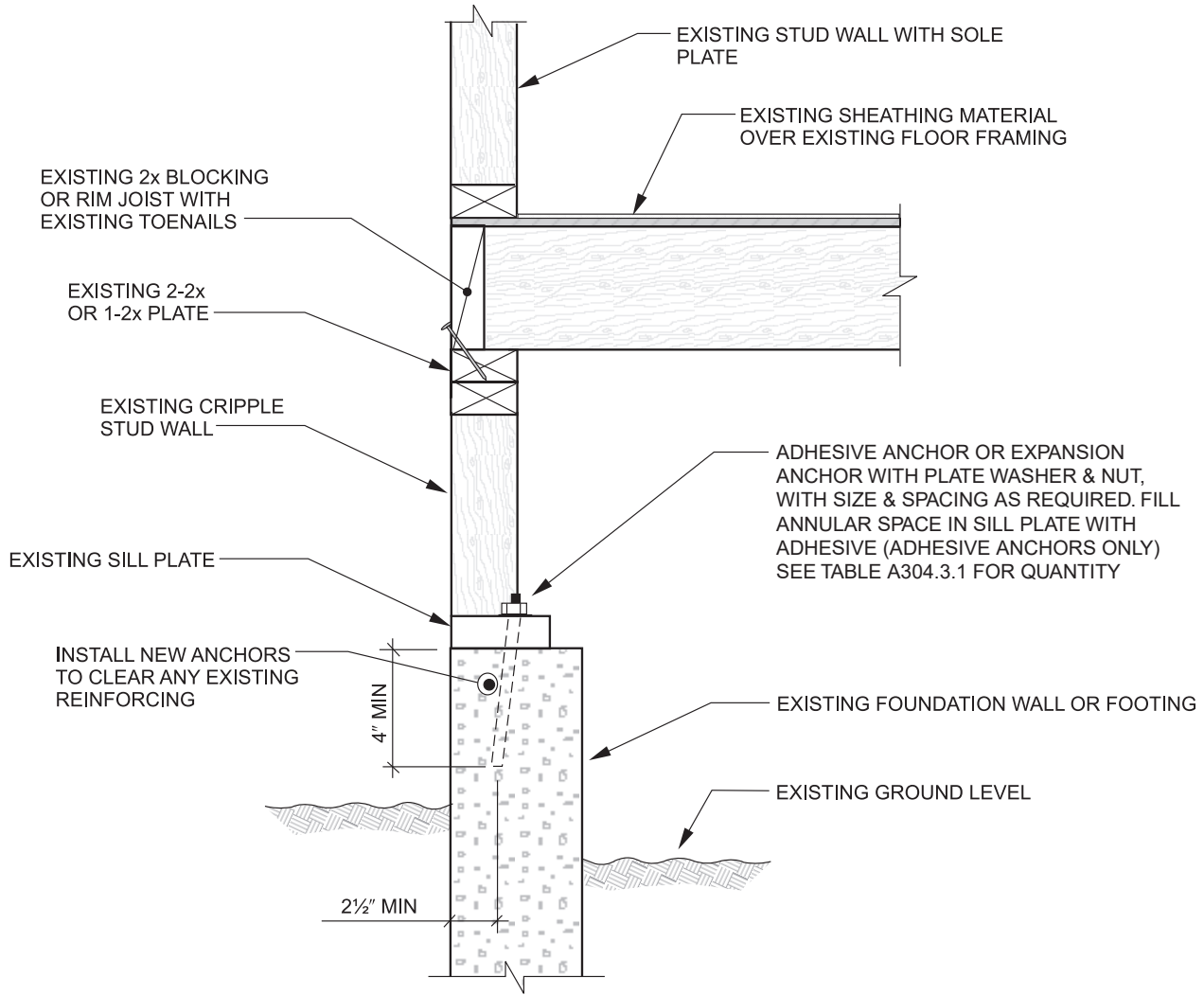

For SI: 1 inch = 25.4 mm.

- a. Plate washers shall comply with the following:
 - $\frac{1}{2}$ -inch anchor or bolt—3 inches \times 3 inches \times 0.229 inch minimum.
 - $\frac{5}{8}$ -inch anchor or bolt—3 inches \times 3 inches \times 0.229 inch minimum.
- A diagonal slot in the plate washer is permitted in accordance with Table A304.3.1, Note b.
- b. See Figure A304.4.1(1) or A304.4.1(2) for cripple wall bracing.

[BS] FIGURE A304.3.1(1)
SILL PLATE BOLTING TO EXISTING FOUNDATION^{a, b}

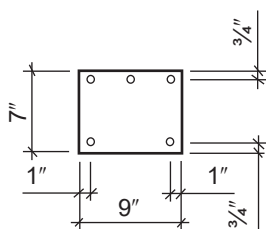
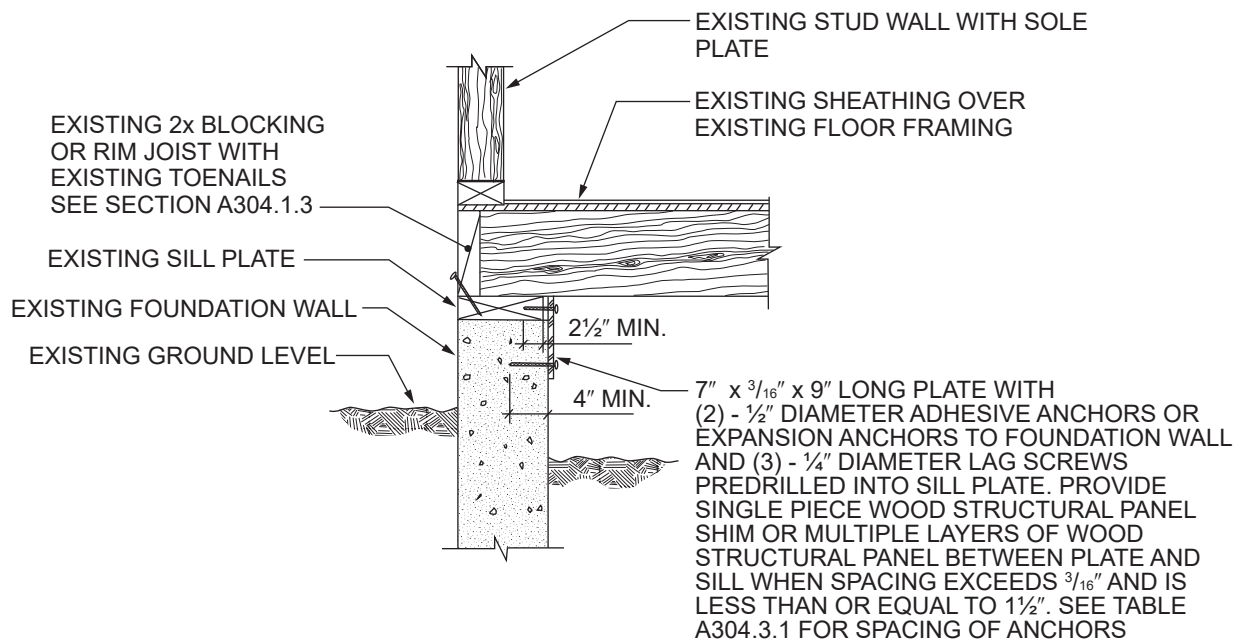

HOLE DIAMETER SHALL NOT EXCEED CONNECTOR DIAMETER BY MORE THAN 1/16"

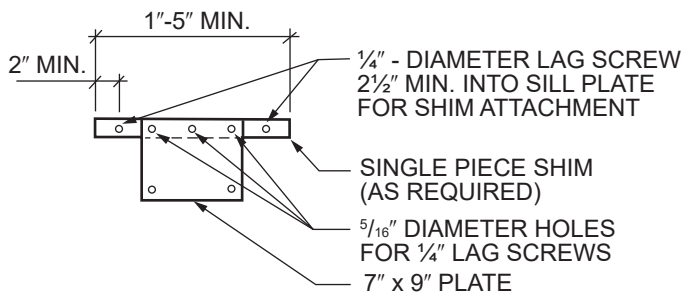

CONNECTION WHEN SHIM SPACE EXCEEDS 3/4" IN. WIDTH UP TO 1 1/2"

For SI: 1 inch = 25.4 mm, 1 foot = 304.8 mm.

- a. If shim space exceeds 1 1/2 inches, alternative details will be required.
- b. Where required, single piece shim shall be naturally durable wood or preservative-treated wood. If preservative-treated wood is used, it shall be isolated from the foundation system with a moisture barrier.

[BS] FIGURE A304.3.1(2)
**ALTERNATIVE SILL PLATE ANCHORING IN EXISTING FOUNDATION—
 WITHOUT CRIPPLE WALLS AND FLOOR FRAMING NOT PARALLEL TO FOUNDATIONS^{a, b}**

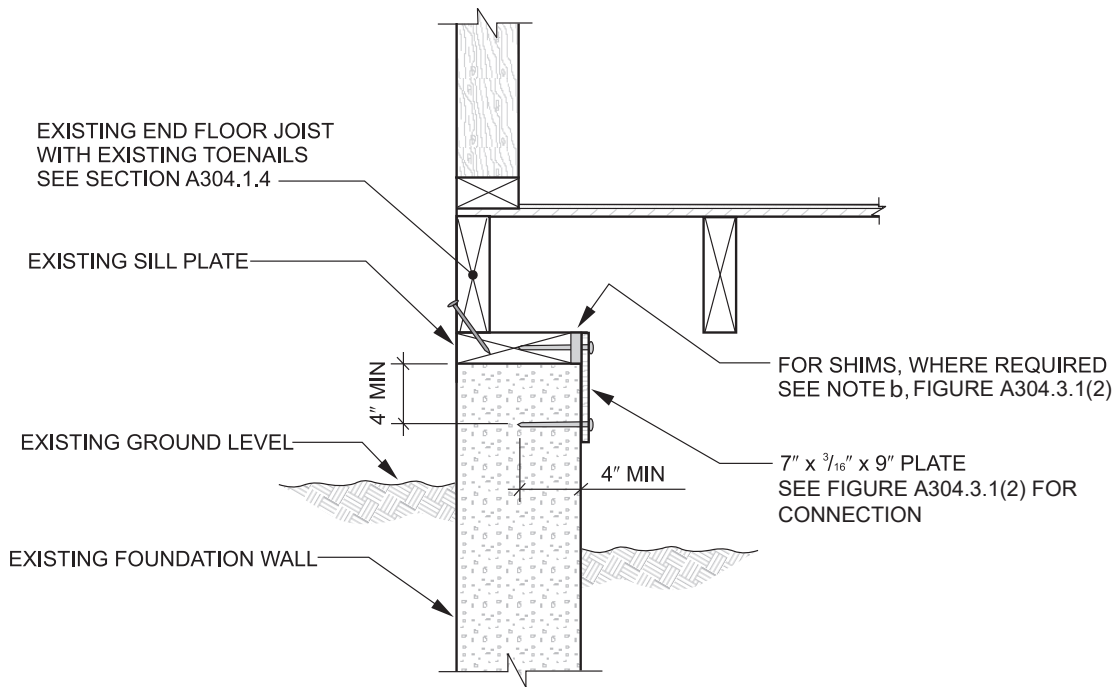

For SI: 1 inch = 25.4 mm.

[BS] FIGURE A304.3.1(3)
ALTERNATIVE SILL PLATE ANCHOR TO EXISTING FOUNDATION WITHOUT CRIPPLE WALL AND FLOOR FRAMING PARALLEL TO FOUNDATIONS

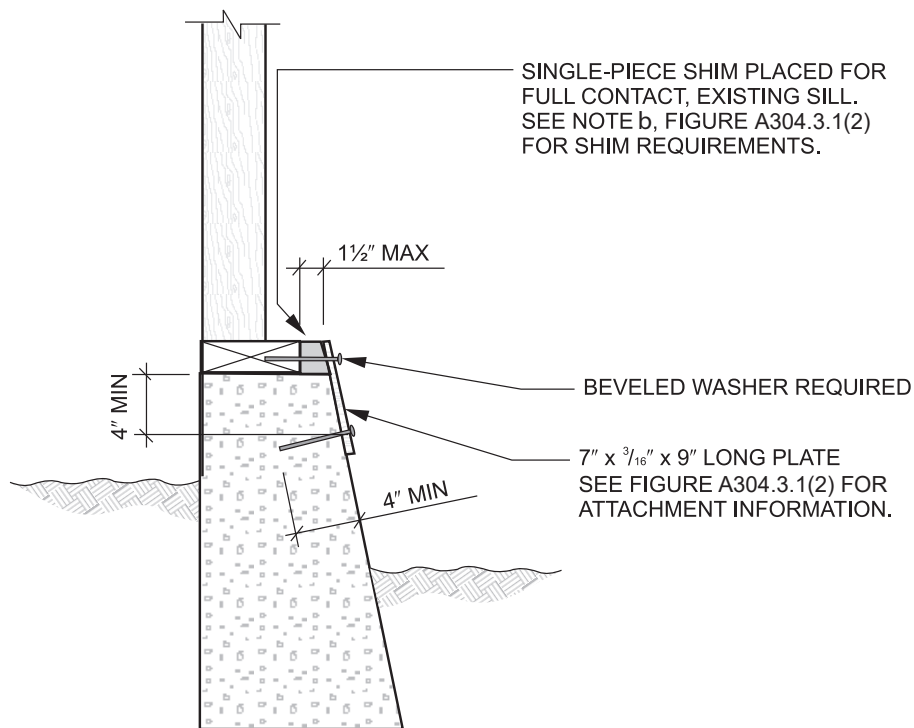

For SI: 1 inch = 25.4 mm.

[BS] FIGURE A304.3.1(4)
SILL PLATE ANCHORING TO EXISTING FOUNDATION—ALTERNATIVE CONNECTION FOR BATTERED FOOTING

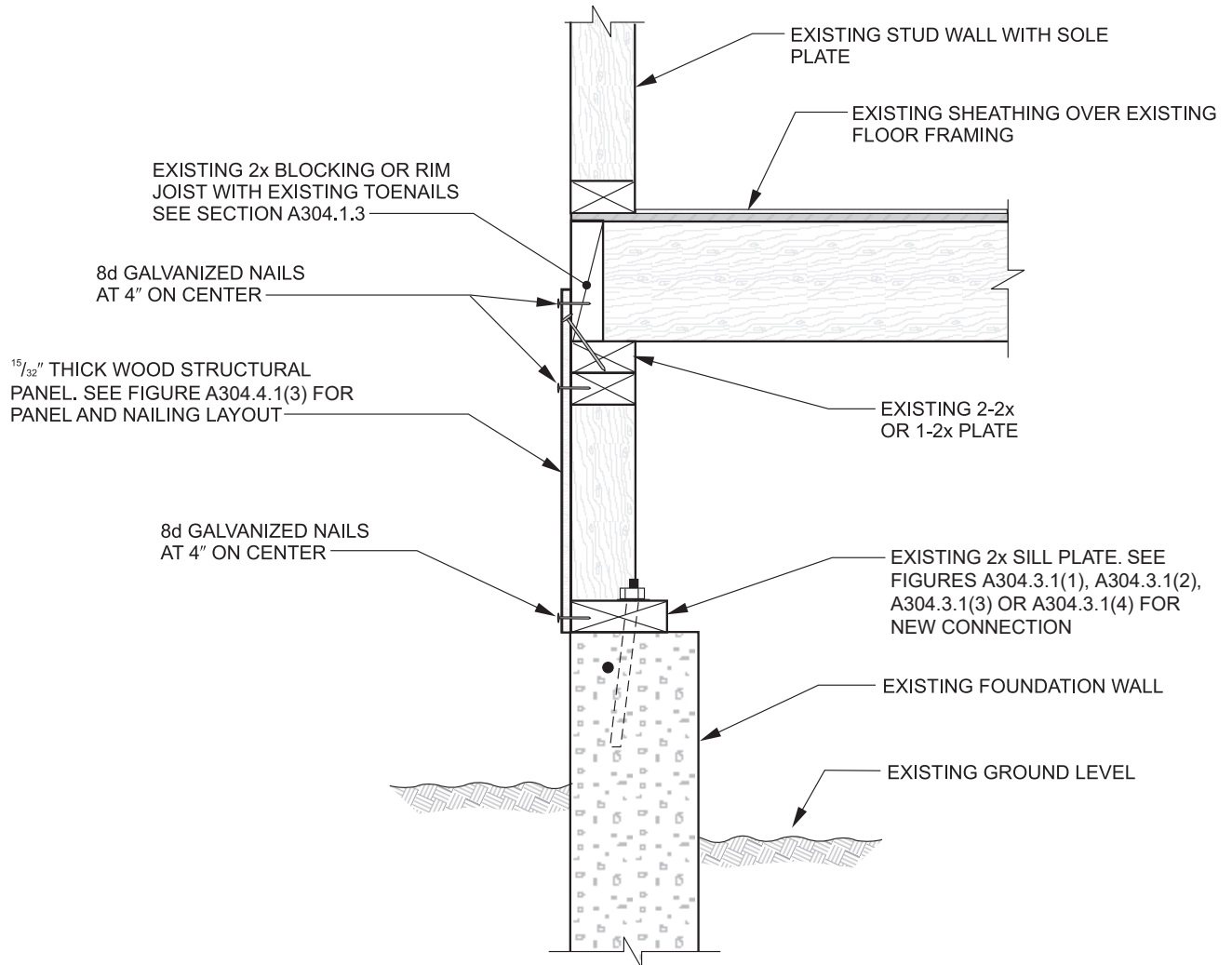

For SI: 1 inch = 25.4 mm.

NOTE: See Figure A304.3.1(1) for sill plate anchoring.

**[BS] FIGURE A304.4.1(1)
CRIPPLE WALL BRACING WITH NEW WOOD STRUCTURAL PANEL ON EXTERIOR FACE OF CRIPPLE STUDS**

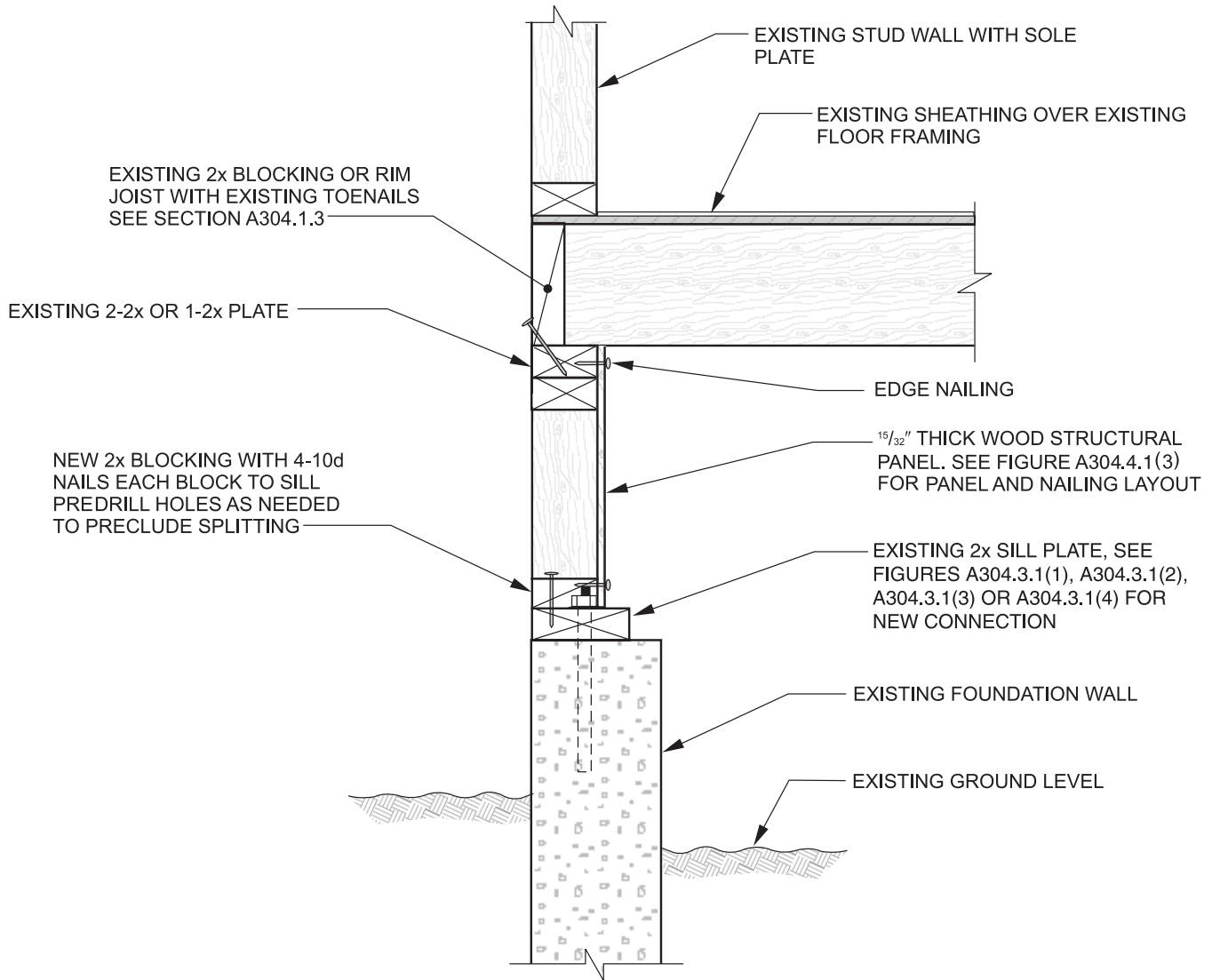

For SI: 1 inch = 25.4 mm.

[BS] FIGURE A304.4.1(2)
CRIPPLE WALL BRACING WITH WOOD STRUCTURAL PANEL ON INTERIOR FACE OF CRIPPLE STUDS

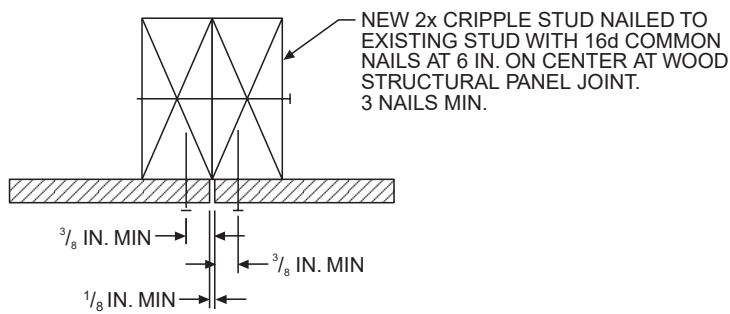
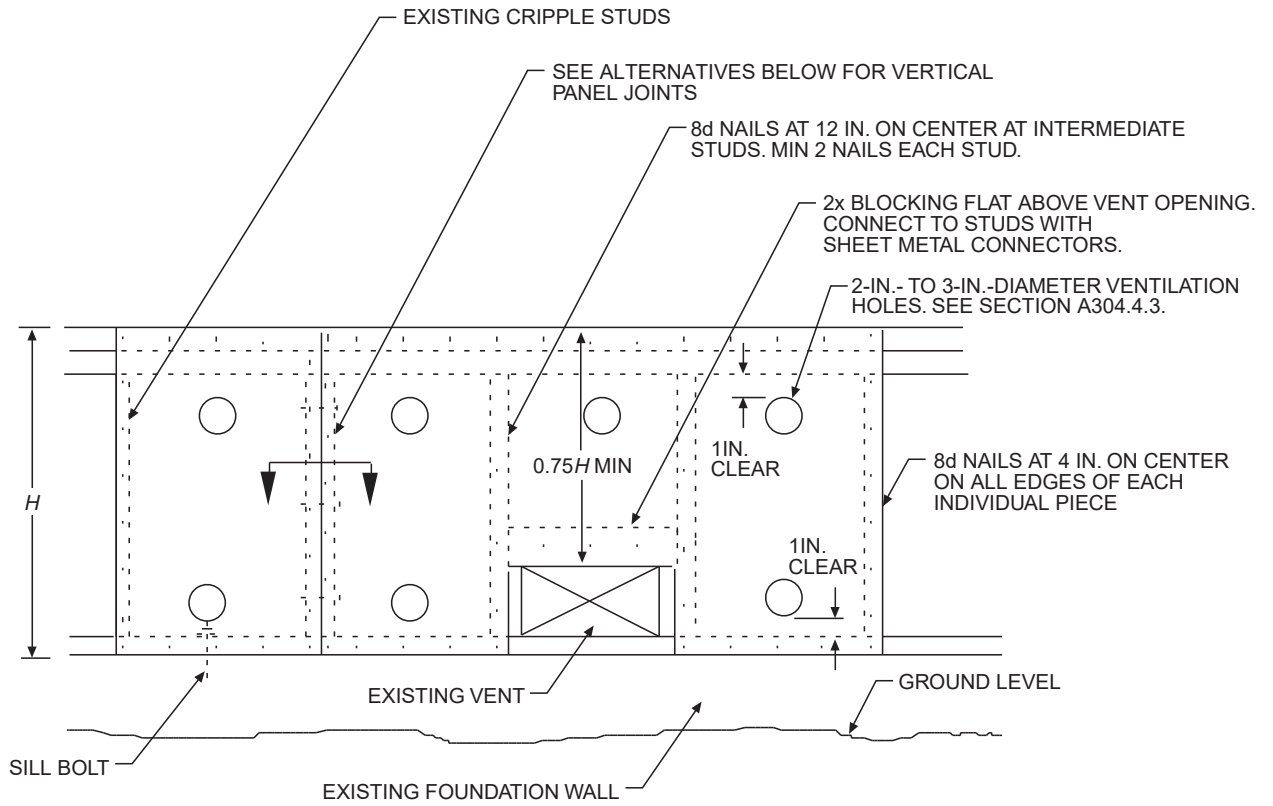

VERTICAL SPLICE AT DOUBLE STUD

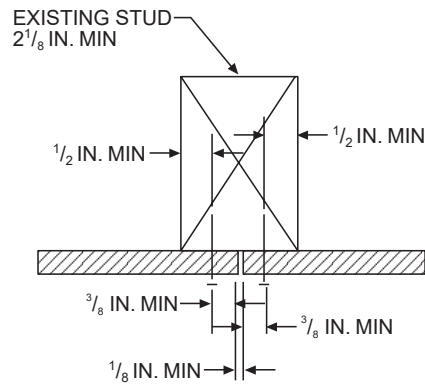

VERTICAL SPLICE AT SINGLE STUD

For SI: 1 inch = 25.4 mm.

[BS] FIGURE A304.4.1(3)
PARTIAL CRIPPLE STUD WALL ELEVATION

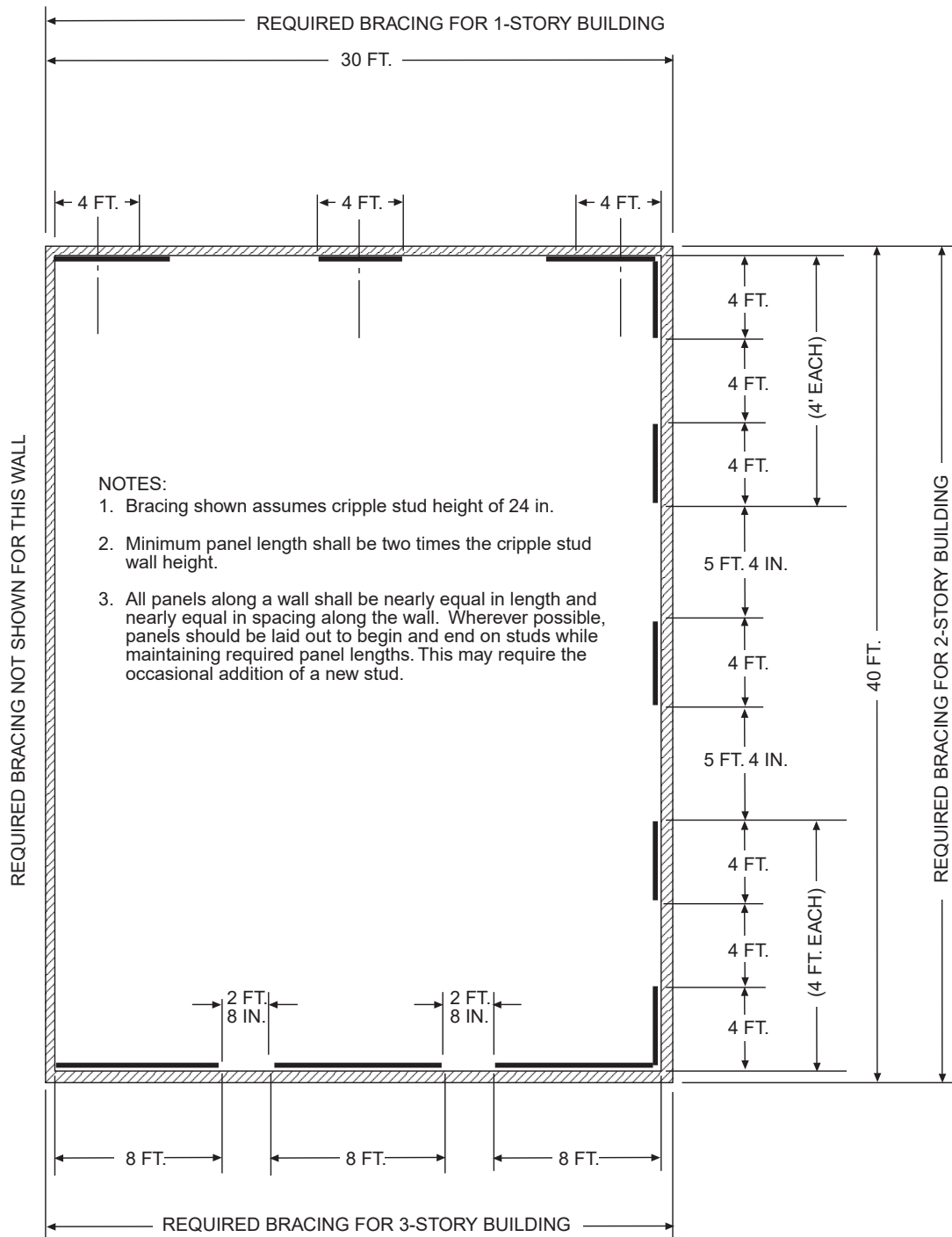

Bracing determination:

- 1-story building—each end and not less than 40% of wall length.^a
 Transverse wall—30 ft. × 0.40 = 12 ft. minimum panel length = 4 ft. 0 in.
- 2-story building—each end and not less than 50% of wall length.^a
 Longitudinal wall—40 ft. × 0.50 = 20 ft. 0 in. minimum of bracing.
- 3-story building—each end and not less than 80% of wall length.^a
 Transverse wall—30 ft. × 0.80 = 24 ft. 0 in. minimum of bracing.

^aSee Table A304.3.1 for buildings with both plaster walls and roofing exceeding 6 psf.

For SI: 1 inch = 25.4 mm, 1 foot = 304.8 mm, 1 pound per square foot = 42.88 N/m².

**[BS] FIGURE A304.4.2
FLOOR PLAN-CRIPPLE WALL BRACING LAYOUT**

CHAPTER A4

EARTHQUAKE RISK REDUCTION IN WOOD-FRAME RESIDENTIAL BUILDINGS WITH SOFT, WEAK OR OPEN FRONT WALLS

SECTION A401 GENERAL

[BS] A401.1 Purpose. The purpose of this chapter is to promote public welfare and safety by reducing the risk of death or injury as a result of the effects of earthquakes on existing wood-frame, multiple-unit residential buildings. The ground motions of past earthquakes have caused the loss of human life, personal injury and property damage in these types of buildings. This chapter creates minimum standards to strengthen the more vulnerable portions of these structures. Where fully followed, these minimum standards will improve the performance of these buildings but will not necessarily prevent all earthquake-related damage.

[BS] A401.2 Scope. The provisions of this chapter shall apply to all existing Occupancy Group R-1 and R-2 buildings of wood construction or portions thereof where the structure has a soft, weak, or open-front wall line, and there exists one or more stories above.

SECTION A402 DEFINITIONS

[BS] A402.1 Definitions. Notwithstanding the applicable definitions, symbols and notations in the building code, the following definitions shall apply for the purposes of this chapter:

[BS] ASPECT RATIO. The span-width ratio for horizontal diaphragms and the height-length ratio for shear walls.

[BS] GROUND FLOOR. Any floor whose elevation is immediately accessible from an adjacent grade by vehicles or pedestrians. The ground floor portion of the structure does not include any floor that is completely below adjacent grades.

[BS] NONCONFORMING STRUCTURAL MATERIALS. Wall bracing materials other than wood structural panels or diagonal sheathing.

[BS] OPEN-FRONT WALL LINE. An exterior wall line, without vertical elements of the lateral force-resisting system, that requires tributary seismic forces to be resisted by diaphragm rotation or excessive cantilever beyond parallel lines of shear walls. Diaphragms that cantilever more than 25 percent of the distance between lines of lateral force-resisting elements from which the diaphragm cantilevers shall be considered to be excessive. Exterior exit balconies of 6 feet (1829 mm) or less in width shall not be considered excessive cantilevers.

[BS] RETROFIT. An improvement of the lateral force-resisting system by *alteration* of existing structural elements or *addition* of new structural elements.

[BS] SOFT WALL LINE. A wall line whose lateral stiffness is less than that required by story drift limitations or deformation compatibility requirements of this chapter. In lieu of analysis, a soft wall line may be defined as a wall line in a story where the story stiffness is less than 70 percent of the story above for the direction under consideration.

[BS] STORY. A story as defined by the building code, including any basement or underfloor space of a building with cripple walls exceeding 4 feet (1219 mm) in height.

[BS] STORY STRENGTH. The total strength of all seismic-resisting elements sharing the same story shear in the direction under consideration.

[BS] WALL LINE. Any length of wall along a principal axis of the building used to provide resistance to lateral loads. Parallel wall lines separated by less than 4 feet (1219 mm) shall be considered to be one wall line for the distribution of loads.

[BS] WEAK WALL LINE. A wall line in a story where the story strength is less than 80 percent of the story above in the direction under consideration.

SECTION A403 ANALYSIS AND DESIGN

[BS] A403.1 General. Modifications required by the provisions in this chapter shall be designed in accordance with the *International Building Code* provisions for new construction, except as modified by this chapter.

Exception: Buildings for which the prescriptive measures provided in Section A404 apply and are used.

Alteration of the existing lateral force-resisting system or vertical load-carrying system shall not reduce the strength or stiffness of the *existing structure*, unless the altered structure would remain in conformance to the building code and this chapter.

[BS] A403.2 Scope of analysis. This chapter requires the *alteration, repair, replacement or addition* of structural elements and their connections to meet the strength and stiffness requirements herein. The lateral load-path analysis shall include the resisting elements and connections from the wood diaphragm immediately above any soft, weak or open-front wall lines to the foundation soil interface or to the uppermost story of a podium structure comprised of steel, masonry, or concrete structural systems that supports the upper, wood-framed structure. Stories above the uppermost story with a soft, weak, or open-front wall line shall be considered in the analysis but need not be modified. The lateral load-path analysis for added structural elements shall include evaluation of the allowable soil-bearing and lateral pressures in accordance with the building code. Where any portion of a building

[BS] A403.9.3 Hold-down connectors.

[BS] A403.9.3.1 Expansion anchors in tension. Expansion anchors that provide tension strength by friction resistance shall not be used to connect hold-down devices to existing concrete or masonry elements.

[BS] A403.9.3.2 Required depth of embedment. The required depth of embedment or edge distance for the anchor used in the hold-down connector shall be provided in the concrete or masonry below any plain concrete slab unless satisfactory evidence is submitted to the *code official* that shows that the concrete slab and footings are of monolithic construction.

SECTION A404**PRESCRIPTIVE MEASURES FOR WEAK STORY**

[BS] A404.1 Limitation. These prescriptive measures shall apply only to two-story buildings and only where deemed appropriate by the *code official*. These prescriptive measures rely on rotation of the second floor diaphragm to distribute the seismic load between the side and rear walls of the ground floor open area. In the absence of an existing floor diaphragm of wood structural panel or diagonal sheathing, a new wood structural panel diaphragm of minimum thickness of $\frac{3}{4}$ inch (19.1 mm) and with 10d common nails at 6 inches (152 mm) on center shall be applied.

[BS] A404.1.1 Additional conditions. To qualify for these prescriptive measures, the following additional conditions need to be satisfied by the retrofitted structure:

1. Diaphragm aspect ratio L/W is less than 0.67, where W is the diaphragm dimension parallel to the soft, weak or open-front wall line and L is the distance in the orthogonal direction between that wall line and the rear wall of the ground floor open area.
2. Minimum length of side shear walls = 20 feet (6096 mm).
3. Minimum length of rear shear wall = three-fourths of the total rear wall length.
4. Plan or vertical irregularities shall not be other than a soft, weak or open-front wall line.
5. Roofing weight less than or equal to 5 pounds per square foot (240 N/m²).
6. Aspect ratio of the full second floor diaphragm meets the requirements of the building code for new construction.

[BS] A404.2 Minimum required retrofit.

[BS] A404.2.1 Anchor size and spacing. The anchor size and spacing shall be not less than $\frac{3}{4}$ inch (19.1 mm) in diameter at 32 inches (813 mm) on center. Where existing anchors are inadequate, supplemental or alternative *approved* connectors (such as new steel plates bolted to the side of the foundation and nailed to the sill) shall be used.

[BS] A404.2.2 Connection to floor above. Shear wall top plates shall be connected to blocking or rim joist at upper floor with not less than 18-gage galvanized steel angle clips $4\frac{1}{2}$ inches (114 mm) long with 12-8d nails spaced

not farther than 16 inches (406 mm) on center, or by equivalent shear transfer methods.

[BS] A404.2.3 Shear wall sheathing. The shear wall sheathing shall be not less than $\frac{15}{32}$ -inch (11.9 mm), 5-Ply Structural I with 10d nails at 4 inches (102 mm) on center at edges and 12 inches (305 mm) on center at field; blocked all edges with 3 by 4 board or larger. Where existing sill plates are less than 3-by thick, place flat 2-by on top of sill between studs, with flat 18-gage galvanized steel clips $4\frac{1}{2}$ inches (114 mm) long with 12-8d nails or $\frac{3}{8}$ -inch-diameter (9.5 mm) lags through blocking for shear transfer to sill plate. Stagger nailing from wall sheathing between existing sill and new blocking. Anchor new blocking to foundation as specified in this section.

[BS] A404.2.4 Shear wall hold-downs. Shear walls shall be provided with hold-down anchors at each end. Two hold-down anchors are required at intersecting corners. Hold-downs shall be *approved* connectors with a minimum $\frac{5}{8}$ -inch-diameter (15.9 mm) threaded rod or other *approved* anchor with a minimum allowable load of 4,000 pounds (17.8 kN). Anchor embedment in concrete shall be not less than 5 inches (127 mm). Tie-rod systems shall be not less than $\frac{5}{8}$ inch (15.9 mm) in diameter unless using high-strength cable. High-strength cable elongation shall not exceed $\frac{5}{8}$ inch (15.9 mm) under a 4,000 pound (17.8 kN) axial load.

SECTION A405**MATERIALS OF CONSTRUCTION**

[BS] A405.1 New materials. New materials shall meet the requirements of the *International Building Code*, except where allowed by this chapter.

[BS] A405.2 Allowable foundation and lateral pressures. The use of default values from the building code for continuous and isolated concrete spread footings shall be permitted. For soil that supports embedded vertical elements, Section A403.4.1 shall apply.

[BS] A405.3 Existing materials. The physical condition, strengths, and stiffnesses of existing building materials shall be taken into account in any analysis required by this chapter. The verification of existing materials conditions and their conformance to these requirements shall be made by physical observation, material testing or record drawings as determined by the registered design professional subject to the approval of the *code official*.

[BS] A405.3.1 Wood-structural-panel shear walls.

[BS] A405.3.1.1 Existing nails. Where the required calculations rely on design values for common nails or surfaced dry lumber, their use in construction shall be verified by exposure.

[BS] A405.3.1.2 Existing plywood. Where verification of the existing plywood is by use of record drawings alone, plywood shall be assumed to be of three plies.

[BS] A405.3.2 Existing wood framing. Wood framing is permitted to use the design stresses specified in the building code under which the building was constructed or other stress criteria *approved* by the *code official*.

[BS] A405.3.3 Existing structural steel. All existing structural steel shall be permitted to be assumed to comply with ASTM A36. Existing pipe or tube columns shall be assumed to be of minimum wall thickness unless verified by testing or exposure.

[BS] A405.3.4 Existing concrete. All existing concrete footings shall be permitted to be assumed to be plain concrete with a compressive strength of 2,000 pounds per square inch (13.8 MPa). Existing concrete compressive strength taken greater than 2,000 pounds per square inch (13.8 MPa) shall be verified by testing, record drawings or department records.

[BS] A405.3.5 Existing sill plate anchorage. The analysis of existing cast-in-place anchors shall be permitted to assume proper anchor embedment for purposes of evaluating shear resistance to lateral loads.

SECTION A406 INFORMATION REQUIRED TO BE ON THE PLANS

[BS] A406.1 General. The plans shall show all information necessary for plan review and for construction and shall accurately reflect the results of the engineering investigation and design. The plans shall contain a note that states that this retrofit was designed in compliance with the criteria of this chapter.

[BS] A406.2 Existing construction. The plans shall show existing diaphragm and shear wall sheathing and framing materials; fastener type and spacing; diaphragm and shear wall connections; continuity ties; collector elements; and the portion of the existing materials that needs verification during construction.

[BS] A406.3 New construction.

[BS] A406.3.1 Foundation plan elements. The foundation plan shall include the size, type, location and spacing of all anchor bolts with the required depth of embedment, edge and end distance; the location and size of all shear walls and all columns for braced frames or moment frames; referenced details for the connection of shear walls, braced frames or moment-resisting frames to their footing; and referenced sections for any grade beams and footings.

[BS] A406.3.2 Framing plan elements. The framing plan shall include the length, location and material of shear walls; the location and material of frames; references on details for the column-to-beam connectors, beam-to-wall connections and shear transfers at floor and roof diaphragms; and the required nailing and length for wall top plate splices.

[BS] A406.3.3 Shear wall schedule, notes and details. Shear walls shall have a referenced schedule on the plans that includes the correct shear wall capacity in pounds per foot (N/m); the required fastener type, length, gage and head size; and a complete specification for the sheathing material and its thickness. The schedule shall also show the required location of 3-inch (76 mm) nominal or two 2-inch (51 mm) nominal edge members; the spacing of shear

transfer elements such as framing anchors or added sill plate nails; the required hold-down with its bolt, screw or nail sizes; and the dimensions, lumber grade and species of the attached framing member.

Notes shall show required edge distance for fasteners on structural wood panels and framing members; required flush nailing at the plywood surface; limits of mechanical penetrations; and the sill plate material assumed in the design. The limits of mechanical penetrations shall be detailed showing the maximum notching and drilled hole sizes.

[BS] A406.3.4 General notes. General notes shall show the requirements for material testing, special inspection and structural observation.

SECTION A407 QUALITY CONTROL

[BS] A407.1 Structural observation, testing and inspection. Structural observation, in accordance with Section 1709 of the *International Building Code*, shall be required for all structures in which seismic retrofit is being performed in accordance with this chapter. Structural observation shall include visual observation of work for conformance to the *approved* construction documents and confirmation of existing conditions assumed during design.

Structural testing and inspection for new construction materials shall be in accordance with the building code, except as modified by this chapter.

CHAPTER A5

REFERENCED STANDARDS

ASCE/SEI

American Society of Civil Engineers
Structural Engineering Institute
1801 Alexander Bell Drive
Reston, VA 20191-4400

7—16: Minimum Design Loads for Buildings and Other Structures with Supplement No. 1
A104, A403.3

ASTM

ASTM International
100 Barr Harbor Drive, P.O. Box C700
West Conshohocken, PA 19428-2959

A36/A36M—14: Specification for Carbon Structural Steel
A405.3.3

A653/A653M—15: Standard Specification for Steel Sheet, Zinc Coated (Galvanized) or Zinc-Iron Alloy-Coated (Galvannealed) by Hot-Dip Process
A304.2.6

B695—04(2009): Standard Specification for Coating of Zinc Mechanically Deposited on Iron And Steel
A304.2.6

C34—13: Specification for Structural Clay Load-Bearing Wall Tile
A106.2.2.2

C140/C140M—15: Standard Test Methods for Sampling and Testing Concrete Masonry Units and Related Units
A106.2.2.2

C496—96/C496M—11: Standard Test Method for Splitting Tensile Strength of Cylindrical Concrete Specimens
A104, A106.2.3.2

C1531—15: Standard Test Methods for In Situ Measurement of Masonry Mortar Joint Shear Strength Index
A106.2.3.1

E488/E488M—15: Standard Test Methods for Strength of Anchors in Concrete and Masonry Elements
A107.5.3

E519/E519M—2010: Standard Test Method for Diagonal Tension (Shear) in Masonry Assemblages
A104, A106.3.3.2

ICC

International Code Council
500 New Jersey Avenue, NW
6th Floor
Washington, DC 20001

BNBC—99: BOCA National Building Code®
A202

IBC—00: International Building Code®
A202.1

IBC—03: International Building Code®
A202.1

IBC—06: International Building Code®
A202.1

IBC—09: International Building Code®
A202.1

IBC—12: International Building Code®
A202.1

APPENDIX B

SUPPLEMENTARY ACCESSIBILITY REQUIREMENTS FOR EXISTING BUILDINGS AND FACILITIES

The provisions contained in this appendix are not mandatory unless specifically referenced in the adopting ordinance.

User note:

About this appendix: Chapter 11 of the International Building Code® contains provisions that set forth requirements for accessibility to buildings and their associated sites and facilities for people with physical disabilities. Sections 410, 605, 705, 906, 1006, 1012.1.4, 1012.8, 1105, 1204.1, 1205.15, 1401.2.5 and 1508 in the code address accessibility provisions and alternatives permitted in existing buildings. Appendix B was added to address accessibility in construction for items that are not typically enforceable through the traditional building code enforcement process.

SECTION B101 QUALIFIED HISTORICAL BUILDINGS AND FACILITIES

B101.1 General. Qualified *historic buildings* and facilities shall comply with Sections B101.2 through B101.5.

B101.2 Qualified historic buildings and facilities. These procedures shall apply to buildings and facilities designated as historic structures that undergo *alterations* or a *change of occupancy*.

B101.3 Qualified historic buildings and facilities subject to Section 106 of the National Historic Preservation Act. Where an *alteration* or *change of occupancy* is undertaken to a qualified *historic building* or facility that is subject to Section 106 of the National Historic Preservation Act, the federal agency with jurisdiction over the undertaking shall follow the Section 106 process. Where the state historic preservation officer or Advisory Council on Historic Preservation determines that compliance with the requirements for accessible routes, ramps, entrances, or toilet facilities would threaten or destroy the historic significance of the building or facility, the alternative requirements of Section 305.9 for that element are permitted.

B101.4 Qualified historic buildings and facilities not subject to Section 106 of the National Historic Preservation Act. Where an *alteration* or *change of occupancy* is undertaken to a qualified *historic building* or facility that is not subject to Section 106 of the National Historic Preservation Act, and the entity undertaking the *alterations* believes that compliance with the requirements for accessible routes, ramps, entrances, or toilet facilities would threaten or destroy the historic significance of the building or facility, the entity shall consult with the state historic preservation officer. Where the state historic preservation officer determines that compliance with the accessibility requirements for accessible routes, ramps, entrances, or toilet facilities would threaten or destroy the historical significance of the building or facility, the alternative requirements of Section 305.9 for that element are permitted.

B101.4.1 Consultation with interested persons. Interested persons shall be invited to participate in the consultation process, including state or local accessibility officials,

individuals with disabilities, and organizations representing individuals with disabilities.

B101.4.2 Certified local government historic preservation programs. Where the state historic preservation officer has delegated the consultation responsibility for purposes of this section to a local government historic preservation program that has been certified in accordance with Section 101 of the National Historic Preservation Act of 1966 [(16 U.S.C. 470a(c)] and implementing regulations (36 CFR 61.5), the responsibility shall be permitted to be carried out by the appropriate local government body or official.

B101.5 Displays. In qualified *historic buildings* and facilities where alternative requirements of Section 1105 are permitted, displays and written information shall be located where they can be seen by a seated person. Exhibits and signs displayed horizontally shall be 44 inches (1120 mm) maximum above the floor.

SECTION B102 FIXED TRANSPORTATION FACILITIES AND STATIONS

B102.1 General. Existing fixed transportation facilities and stations shall comply with Section B102.2.

B102.2 Existing facilities—key stations. Rapid rail, light rail, commuter rail, intercity rail, high-speed rail and other fixed guideway systems, altered stations, and intercity rail and key stations, as defined under criteria established by the Department of Transportation in Subpart C of 49 CFR Part 37, shall comply with Sections B102.2.1 through B102.2.3.

B102.2.1 Accessible route. One accessible route, or more, from an accessible entrance to those areas necessary for use of the transportation system shall be provided. The accessible route shall include the features specified in Section E109.2 of the *International Building Code*, except that escalators shall comply with *International Building Code* Section 3004.2.2. Where technical unfeasibility in existing stations requires the accessible route to lead from the public way to a paid area of the transit system, an accessible fare collection machine complying with *Inter-*

APPENDIX B

national Building Code Section E109.2.3 shall be provided along such accessible route.

B102.2.2 Platform and vehicle floor coordination. Station platforms shall be positioned to coordinate with vehicles in accordance with applicable provisions of 36 CFR Part 1192. Low-level platforms shall be 8 inches (250 mm) minimum above top of rail.

Exception: Where vehicles are boarded from sidewalks or street-level, low-level platforms shall be permitted to be less than 8 inches (250 mm).

B102.2.3 Direct connections. New direct connections to commercial, retail, or residential facilities shall, to the maximum extent feasible, have an accessible route complying with Section 305.7 from the point of connection to boarding platforms and transportation system elements used by the public. Any elements provided to facilitate future direct connections shall be on an accessible route connecting boarding platforms and transportation system elements used by the public.

SECTION B103 DWELLING UNITS AND SLEEPING UNITS

B103.1 Communication features. Where dwelling units and sleeping units are altered or added, the requirements of Section E104.3 of the *International Building Code* shall apply only to the units being altered or added until the number of units with accessible communication features complies with the minimum number required for new construction.

SECTION B104 REFERENCED STANDARDS

Y3.H626 2P	National Historic Preservation Act of 1966, as amended J101.3, 3rd Edition Washington, DC: J101.3.2 US Government Printing Office, 1993	B101.3, B101.4, B101.4.2
IBC—18	<i>International Building Code</i> ®, Washington, DC: International Code Council, 2017	B102.2.1, B103.1
36 CFR Part 1192	Americans with Disabilities Act Guidelines for Transportation Vehicles—Rapid Rail Vehicles and Systems	B102.2.2
49 CFR Part 37 Subpart C	Alteration of Transportation Facilities by Public Entities Department of Transportation 400 7th Street SW, Room 8102 Washington, DC 20590-0001	B102.2

APPENDIX C: Guidelines for the Wind Retrofit of Existing Buildings

CHAPTER C1

GABLE END RETROFIT FOR HIGH-WIND AREAS

The provisions contained in this appendix are not mandatory unless specifically referenced in the adopting ordinance.

User note:

About this appendix: Appendix C is intended to provide guidance for retrofitting existing structures to strengthen their resistance to wind forces. This appendix is similar in scope to Appendix A, which addresses seismic retrofits for existing buildings, except that the subject matter is related to wind retrofits. These retrofits are voluntary measures that serve to better protect the public and reduce damage from high-wind events for existing buildings.

The purpose of this appendix is to provide prescriptive alternatives for addressing retrofit of buildings in high-wind areas. Currently there are two chapters that deal with the retrofit of gable ends and the fastening of roof decks, Appendix Chapters C1 and C2, respectively.

SECTION C101 GENERAL

[BS] C101.1 Purpose. This chapter provides prescriptive methods for partial structural retrofit of an *existing building* to increase its resistance to out-of-plane wind loads. It is intended for voluntary use and for reference by mitigation programs. The provisions of this chapter do not necessarily satisfy requirements for new construction. Unless specifically cited, the provisions of this chapter do not necessarily satisfy requirements for structural improvements triggered by *addition, alteration, repair, change of occupancy*, building relocation or other circumstances.

[BS] C101.2 Eligible buildings and gable end walls. The provisions of this chapter are applicable only to buildings that meet the following eligibility requirements:

1. The building is not more than three stories tall, from adjacent grade to the bottom plate of each gable end wall being retrofitted with this chapter.
2. The building is classified as Occupancy Group R3 or is within the scope of the *International Residential Code*.
3. The structure includes one or more wood-framed gable end walls, either conventionally framed or metal-plate-connected.

In addition, the provisions of this chapter are applicable only to gable end walls that meet the following eligibility requirements:

4. Each gable end wall has or shall be provided with studs or vertical webs spaced 24 inches (610 mm) on center maximum.
5. Each gable end wall has a maximum height of 16 feet (4877 mm).

[BS] C101.3 Compliance. Eligible gable end walls in eligible buildings may be retrofitted in accordance with this chapter. Other modifications required for compliance with this chapter shall be designed and constructed in accordance with the *International Building Code* or *International Residential Code* provisions for new construction, except as specifically provided for by this chapter.

SECTION C102 DEFINITIONS

[BS] C102.1 Definitions. *The following words and terms shall, for the purposes of this chapter, have the meanings shown herein.*

[BS] ANCHOR BLOCK. A piece of lumber secured to horizontal braces and filling the gap between existing framing members for the purpose of restraining horizontal braces from movement perpendicular to the framing members.

[BS] COMPRESSION BLOCK. A piece of lumber used to restrain in the compression mode (force directed towards the interior of the attic) an existing or retrofit stud. It is attached to a horizontal brace and bears directly against the existing or retrofit stud.

[BS] CONVENTIONALLY FRAMED GABLE END. A gable end framed with studs whose faces are perpendicular to the gable end wall.

[BS] GABLE END FRAME. A factory or site-fabricated frame, installed as a complete assembly that incorporates vertical webs with their faces parallel to the plane of the frame.

[BS] HORIZONTAL BRACE. A piece of lumber used to restrain both compression and tension loads applied by a retrofit stud. It is typically installed horizontally on the top of attic floor framing members (truss bottom chords or ceiling joists) or on the bottom of pitched roof framing members (truss top chord or rafters).

[BS] HURRICANE TIES. Manufactured metal connectors designed to provide uplift and lateral restraint for roof framing members.

[BS] NAIL PLATE. A manufactured metal plate made of galvanized steel with factory-punched holes for fasteners. A nail plate may have the geometry of a strap.

[BS] RETROFIT. The voluntary process of strengthening or improving buildings or structures, or individual components of buildings or structures for the purpose of making existing conditions better serve the purpose for which they were originally intended or the purpose that current building codes intend.

[BS] RETROFIT STUD. A lumber member used to structurally supplement an existing gable end wall stud or gable end frame web.

[BS] STUD-TO-PLATE CONNECTOR. A manufactured metal connector designed to connect studs to plates.

**SECTION C103
MATERIALS OF CONSTRUCTION**

[BS] C103.1 Existing materials. Existing wood materials that will be part of the retrofitting work (such as trusses, rafters, ceiling joists, top plates and wall studs) shall be in sound condition and free from defects or damage that substantially reduces the load-carrying capacity of the member. Any wood materials found to be damaged or deteriorated shall be strengthened or replaced with new materials to provide a net dimension of sound wood equivalent to its undamaged original dimensions.

[BS] C103.2 New materials. All new materials shall comply with the standards for those materials as specified in the *International Building Code* or the *International Residential Code*.

[BS] C103.3 Material specifications for retrofits. Materials for retrofitting gable end walls shall comply with Table C103.3.

[BS] C103.4 Twists in straps. Straps shall be permitted to be twisted or bent where they transition between framing members or connection points. Straps shall be bent only once at a given location though it is permissible that they be bent or twisted at multiple locations along their length.

[BS] C103.5 Fasteners. Fasteners shall meet the requirements of Table C103.5, Sections C103.5.1 and C103.5.2, and shall be permitted to be screws or nails meeting the minimum length requirement shown in the figures and specified in the tables of this appendix. Fastener spacing shall meet the requirements of Section C103.5.3.

[BS] C103.5.1 Screws. Unless otherwise indicated in the appendix, screw sizes and lengths shall be in accordance with Table C103.5. Permissible screws include deck screws and wood screws. Screws shall have not less than 1 inch (25 mm) of thread. Fine threaded screws or drywall screws shall not be permitted. Select the largest possible diameter screw such that the shank adjacent to the head fits through the hole in the strap.

[BS] C103.5.2 Nails. Unless otherwise indicated in this appendix, nail sizes and lengths shall be in accordance with Table C103.5.

[BS] C103.5.3 General fastener spacing. Fastener spacing for shear connections of lumber-to-lumber shall meet the requirements shown in Figure C103.5.3 and the following conditions.

[BS] C103.5.3.1 General fastener spacing. Fastener spacing shall meet the following conditions except as provided for in Section C103.5.3.

The distance between fasteners and the edge of lumber that is less than 3¹/₂ inches deep (89 mm) in the direction of the fastener length shall be not less than 3³/₄ inch (19.1 mm).

1. The distance between fasteners and the edge of lumber that is more than 2 inches (51 mm) thick in the direction of the fastener length shall be not less than 1¹/₂ inch (12.7 mm).
2. The distance between a fastener and the end of lumber shall be not less than 2¹/₂ inches (64 mm).
3. The distance between fasteners parallel to the grain (center-to-center) shall be not less than 2¹/₂ inches (64 mm).

**[BS] TABLE C103.3
MATERIAL SPECIFICATIONS FOR RETROFITS^a**

COMPONENT	MINIMUM SIZE OR THICKNESS	MINIMUM MATERIAL GRADE	MINIMUM CAPACITY
Anchor blocks, compression blocks, and horizontal braces	2 x 4 nominal lumber	#2 Spruce-Pine-Fir or better	NA
Nail plates	20 gage thickness 8d minimum nail holes	Galvanized sheet steel	NA
Retrofit studs	2 x 4 nominal lumber	#2 Spruce-Pine-Fir or better	NA
Gusset angle	14 gage thickness	Galvanized sheet steel	350 pounds uplift and lateral load
Stud-to-plate connector	20 gage thickness	Galvanized sheet steel	500 pounds uplift
Metal plate connectors, straps, and anchors	20 gage thickness	Galvanized sheet steel	NA

For SI: 1 foot = 304.8mm, 1 pound = 4.4 N.

NA = Not Applicable.

a. Metal plate connectors, nail plates, stud-to-plate connectors, straps and anchors shall be products approved for connecting wood-to-wood or wood-to-concrete as appropriate.

**[BS] TABLE C103.5
NAIL AND SCREW REQUIREMENTS**

FASTENER TYPE	MINIMUM SHANK DIAMETER	MINIMUM HEAD DIAMETER	MINIMUM FASTENER LENGTH
#8 screws	NA	0.28 inches	1- ¹ / ₄ inches
8d common nails	0.131 inches	0.28 inches	2- ¹ / ₂ inches
10d common nails	0.148 inches	0.28 inches	3 inches

For SI: 1 inch = 25.4 mm.

NA = Not Applicable.

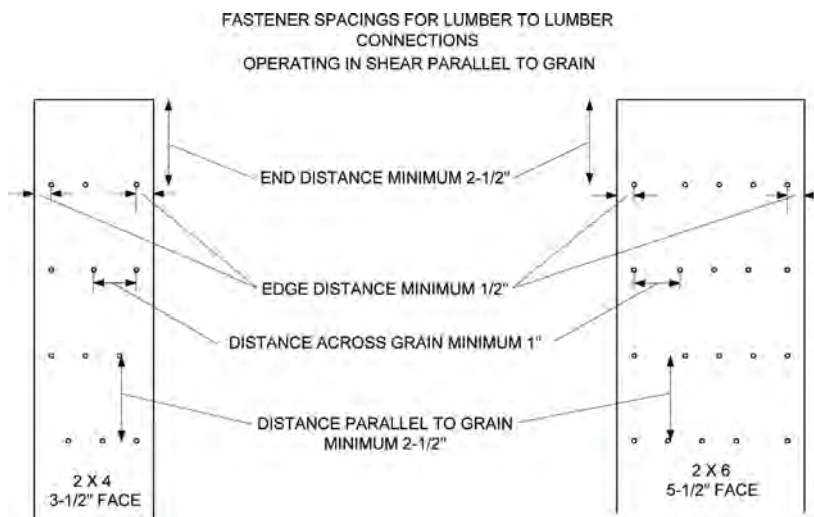

For SI: 1 inch = 25.4 mm.

[BS] FIGURE C103.5.3
FASTENER SPACINGS FOR LUMBER-TO-LUMBER CONNECTIONS OPERATING IN SHEAR PARALLEL TO GRAIN

4. The distance between fasteners perpendicular to the grain (center-to-center) in lumber that is less than $3\frac{1}{2}$ inches (89 mm) deep in the direction of the fastener length shall be 1 inch (25 mm).
5. The distance between fasteners perpendicular to the grain (center-to-center) in lumber that is more than 2 inches (51 mm) thick in the direction of the fastener length shall be $\frac{1}{2}$ inch (12.7 mm).

[BS] C103.5.3.2 Wood-to-wood connections of two members each 2 inches or less in thickness. Wood-to-wood connections fastener spacing shall meet the following conditions.

1. The distance between fasteners parallel to grain (center-to-center) shall be not less than $2\frac{1}{2}$ inches (64 mm).
2. The distance between fasteners across grain (center-to-center) shall be not less than 1 inch (25 mm).
3. For wood-to-wood connections of lumber at right angles, fasteners shall be spaced not less than $2\frac{1}{2}$ inches (64 mm) parallel to the grain and 1 inch (25 mm) perpendicular to the grain in any direction.

[BS] C103.5.3.3 Metal connectors for wood-to-wood connections. Metal connectors for wood-to-wood connections shall meet the following conditions.

1. Fastener spacing to edge or ends of lumber shall be as dictated by the prefabricated holes in the connectors and the connectors shall be installed in a configuration that is similar to that shown by the connector manufacturer.
2. Fasteners in $1\frac{1}{4}$ -inch-wide (32 mm) metal straps that are installed on the narrow face of lumber shall be a minimum $\frac{1}{4}$ inch (6.4 mm) from either edge of the lumber. Consistent with Section

C103.5.3.1, fasteners shall be permitted to be spaced according to the fastener holes fabricated into the strap.

3. Fasteners in metal nail plates shall be spaced not less than $\frac{1}{2}$ inch (12.7 mm) perpendicular to grain and not less than $1\frac{1}{2}$ inches (38 mm) parallel to grain.

SECTION C104 RETROFITTING GABLE END WALLS TO ENHANCE WIND RESISTANCE

[BS] C104.1 General. These prescriptive methods of retrofitting are intended to increase the resistance of existing gable end construction for out-of-plane wind loads resulting from high-wind events. The ceiling diaphragm shall be comprised of minimum $\frac{1}{2}$ -inch-thick (12.7 mm) gypsum board, minimum nominal $\frac{3}{8}$ -inch-thick (9.5 mm) wood structural panels, or plaster. An overview isometric drawing of one type of gable end retrofit to improve wind resistance is shown in Figure C104.1.

[BS] C104.2 Horizontal braces. Horizontal braces shall be installed perpendicular to the roof and ceiling framing members at the location of each existing gable end stud greater than 3 feet (91 cm) in length. Unless it is adjacent to an omitted horizontal brace location, horizontal braces shall be minimum 2-inch by 4-inch (38 mm by 89 mm) dimensional lumber as defined in Section C103.3. A single horizontal brace is required at the top and bottom of each gable end stud for Retrofit Configuration A, B, or C. Two horizontal braces are required at the top and bottom of each gable end stud for Retrofit Configuration D. Maximum heights of gable end wall studs and associated retrofit studs for each Retrofit Configuration shall not exceed the values listed in Table C104.2. Horizontal braces shall be oriented with their wide faces across the roof or ceiling framing members, be fastened to not fewer

APPENDIX C

than three framing members, and extend not less than 6 feet (183 cm) measured perpendicularly from the gable end plus 2½ inches (64 mm) beyond the last top chord or bottom chord member (rafter or ceiling joist) from the gable end as shown in Figures C104.2(1), C104.2(2), C104.2(3) and C104.2(4).

[BS] C104.2.1 Existing gable end studs. If the spacing of existing vertical gable end studs is greater than 24 inches (64 mm), a new stud and corresponding horizontal braces shall be installed such that the maximum spacing between

existing and added studs shall be not greater than 24 inches (64 mm). Additional gable end wall studs shall not be required at locations where their length would be 3 feet (914 mm) or less. Each end of each required new stud shall be attached to the existing roofing framing members (truss top chord or rafter and truss bottom chord or ceiling joist) using not fewer than two 3-inch (76 mm) toenail fasteners (#8 wood screws or 10d nails) and a metal connector with minimum uplift capacity of 175 pounds (778 N), or nail plates with not fewer than four 1¼-inch-long (32 mm) fasteners (No. 8 wood screws or 8d nails).

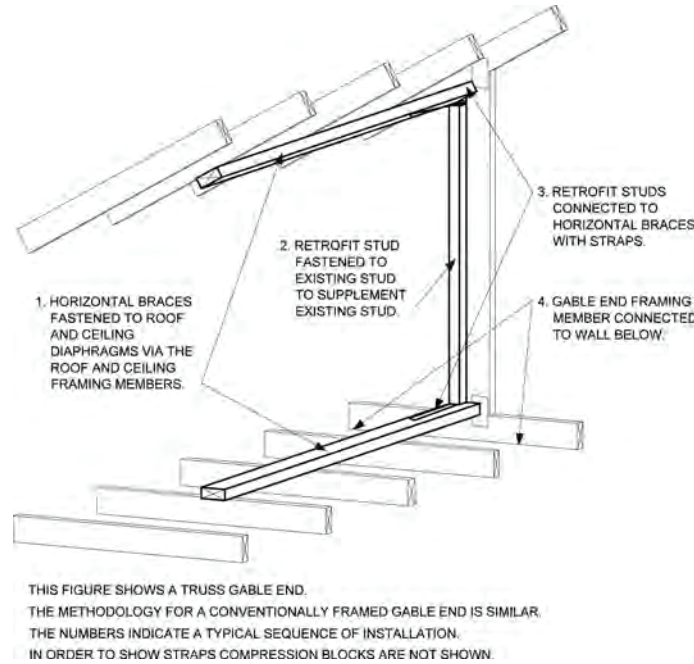

**[BS] FIGURE C104.1
BASIC GABLE END RETROFIT METHODOLOGY**

**[BS] TABLE C104.2
STUD LENGTH LIMITATIONS BASED ON EXPOSURE AND DESIGN WIND SPEED**

EXPOSURE CATEGORY	MAXIMUM 3-SEC GUST BASIC WIND SPEED ^a	MAXIMUM HEIGHT OF GABLE END RETROFIT STUD ^b			
C	140	8'-0"	11'-3"	14'-9"	16'-0"
C	150	7'-6"	10'-6"	13'-6"	16'-0"
C	165	7'-0"	10'-0"	12'-3"	16'-0"
C	180	7'-0"	10'-0"	12'-3"	16'-0"
C	190	6'-6"	8'-9"	11'-0"	16'-0"
B	140	8'-0"	12'-3"	16'-0"	NR ^c
B	150	8'-0"	11'-3"	14'-9"	16'-0"
B	165	8'-0"	11'-3"	14'-9"	16'-0"
B	180	7'-6"	10'-6"	13'-6"	16'-0"
B	190	7'-0"	10'-0"	12'-3"	16'-0"
	Retrofit Configuration	A	B	C	D

For SI: 1 inch = 25.4 mm, 1 foot = 304.8 mm.

NR = Not Required.

- a. Interpolation between given wind speeds is not permitted.
- b. Existing gable end studs less than or equal to 3 feet 0 inches in height shall not require retrofitting.
- c. Configuration C is acceptable to 16 feet 0 inches maximum height.

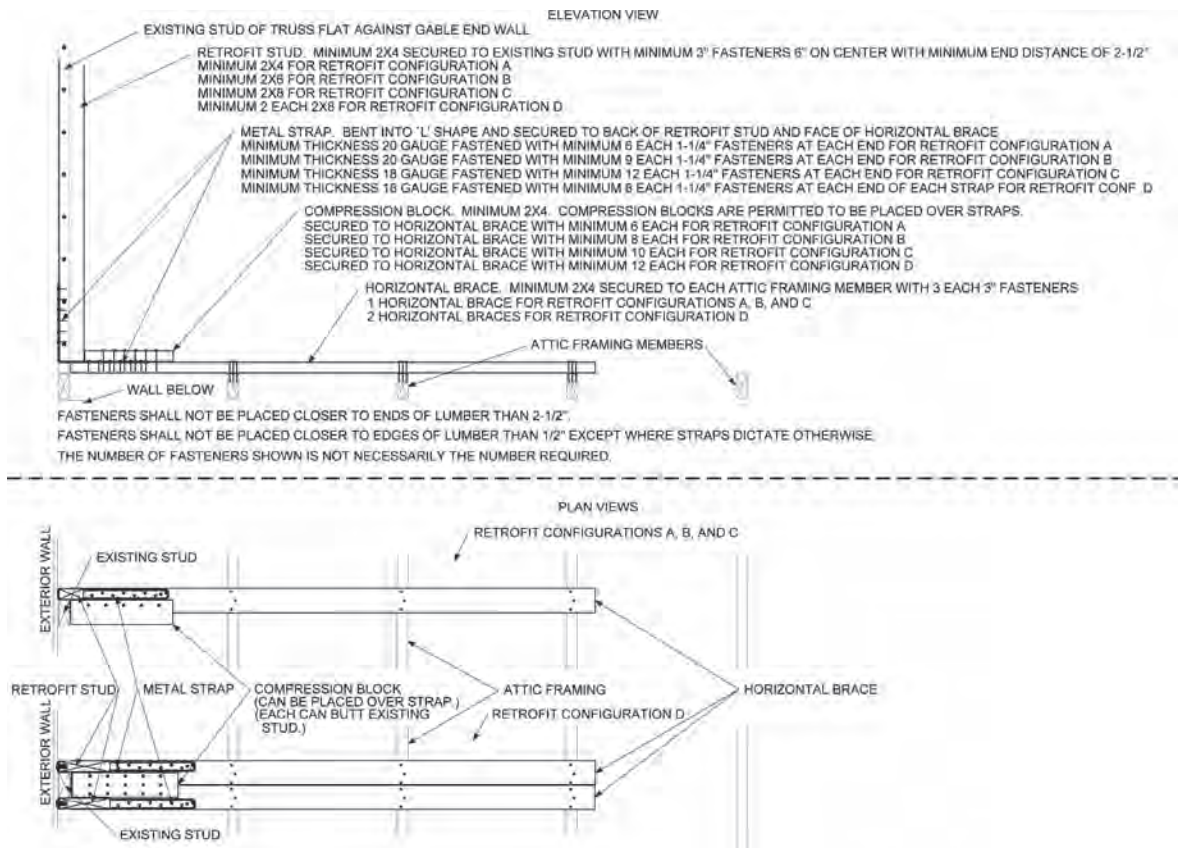

For SI: 1 inch = 25.4 mm.

**[BS] FIGURE C104.2(1)
 TRUSS FRAMED GABLE END**

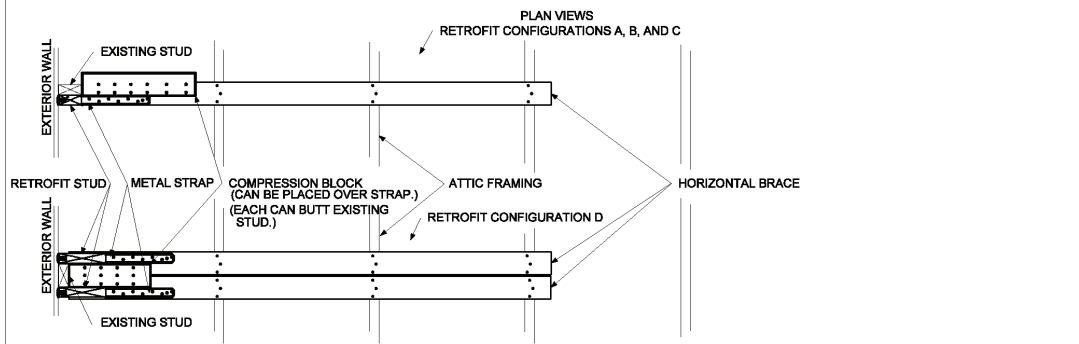
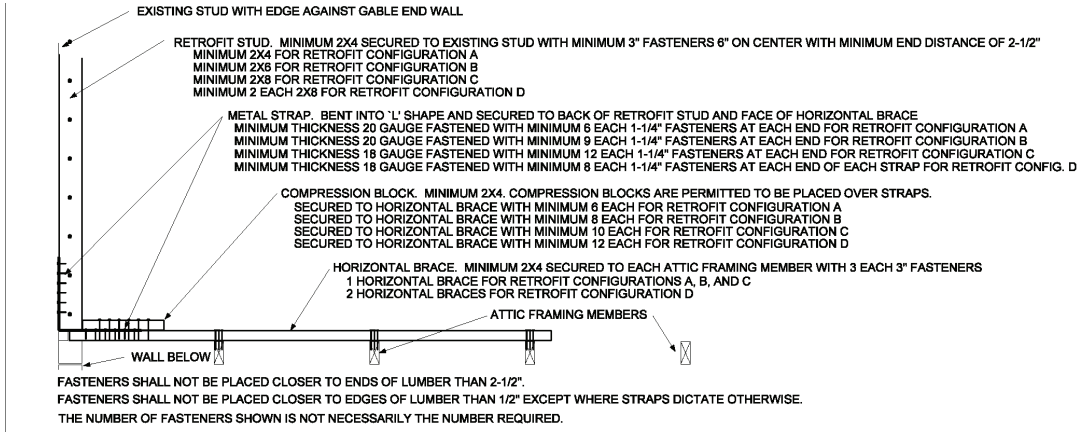

For SI: 1 inch = 25.4 mm.

[BS] FIGURE C104.2(2)
 CONVENTIONALLY FRAMED GABLE END L-BENT STRAP

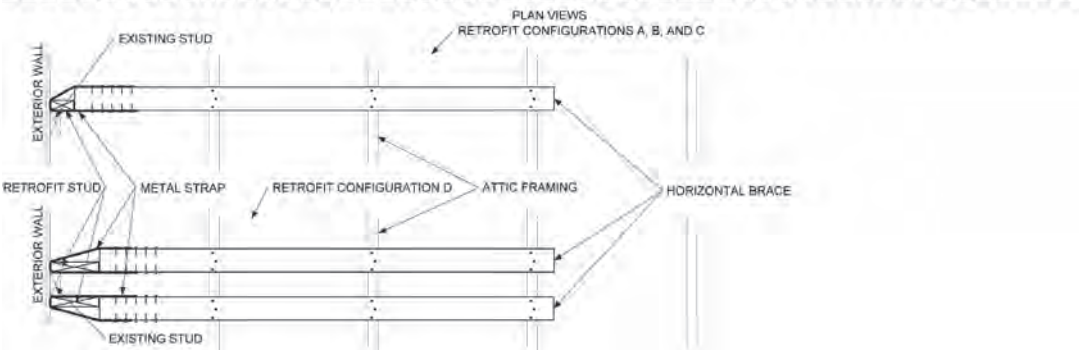
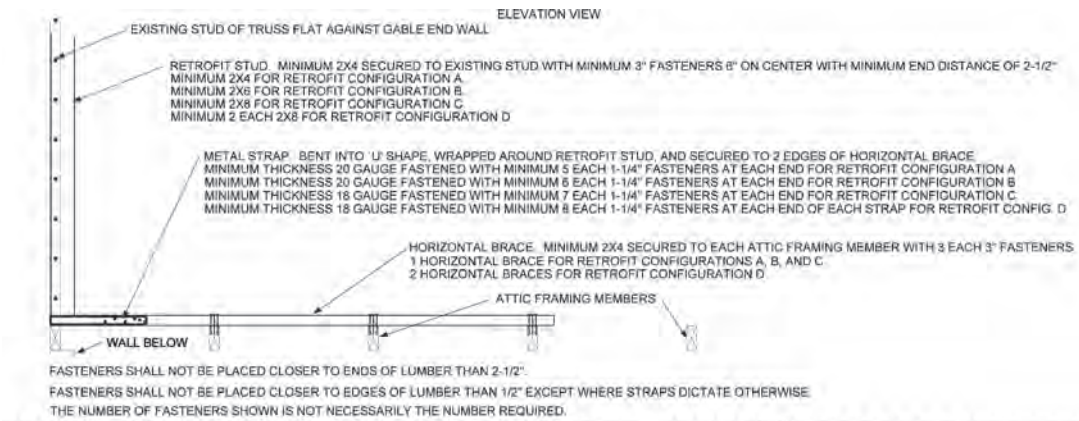

For SI: 1 inch = 25.4 mm.

[BS] FIGURE C104.2(3)
 TRUSS FRAMED GABLE END U-BENT STRAP

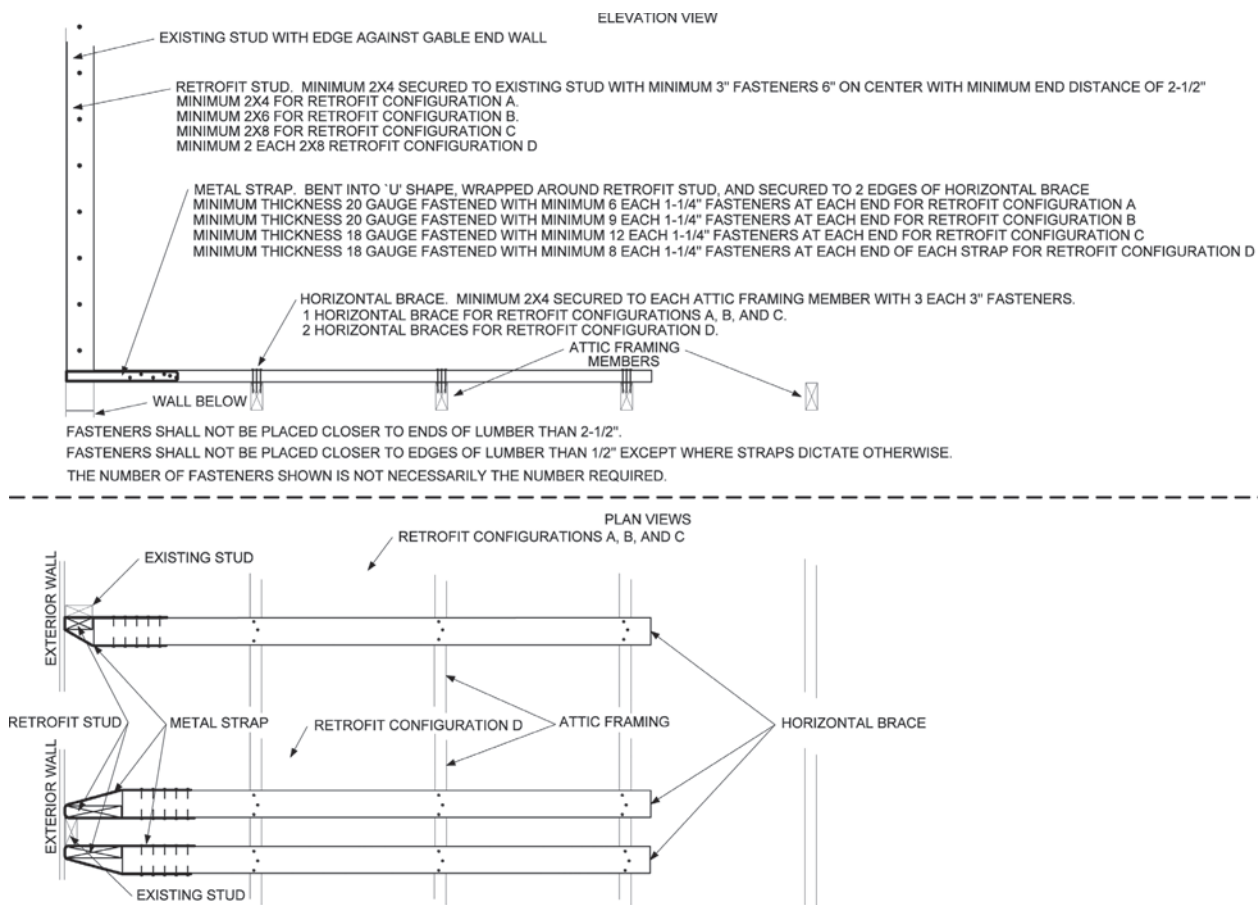

For SI: 1 inch = 25.4 mm.

**[BS] FIGURE C104.2(4)
 CONVENTIONALLY FRAMED GABLE END U-BENT STRAP**

[BS] C104.2.2 Main method of installation. Each horizontal brace shall be fastened to each existing roof or ceiling member that it crosses using three 3-inch-long (76 mm) fasteners (No. 8 wood screws or 10d nails) as indicated in Figure C104.2(1) and Figure C104.2(3) for trusses and Figure C104.2(2) and Figure C104.2(4) for conventionally framed gable end walls. Alternative methods for providing horizontal bracing of the gable end studs as provided in Sections C104.2.3 through C104.2.9 shall be permitted.

[BS] C104.2.3 Omitted horizontal brace. Where conditions exist that prevent installation in accordance with Sec-

tion C104.2.2, horizontal braces shall be permitted to be omitted for height limitations corresponding to Retrofit Configurations A and B as defined in Table C104.2 provided that installation is as indicated in Figure C104.2.3 and provided that all of the following conditions are met. This method is not permitted for Retrofit Configurations C or D.

1. There shall be not fewer than two horizontal braces on each side of an omitted horizontal brace or not fewer than one horizontal brace if it is the end horizontal brace. Omitted horizontal braces must be separated by not fewer than two horizontal braces

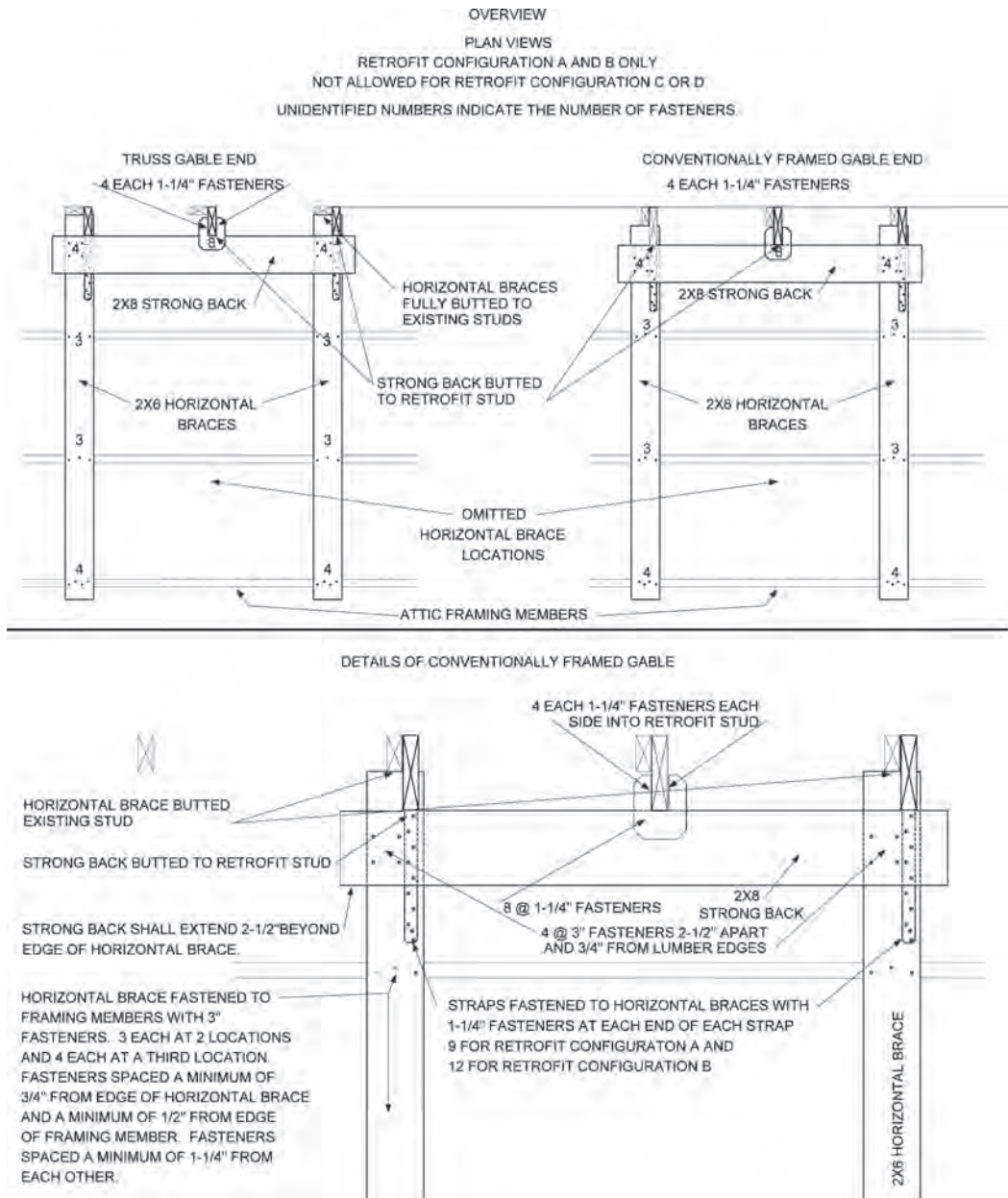

For SI: 1 inch = 25.4 mm.

**[BS] FIGURE C104.2.3
OMITTED HORIZONTAL BRACE**

APPENDIX C

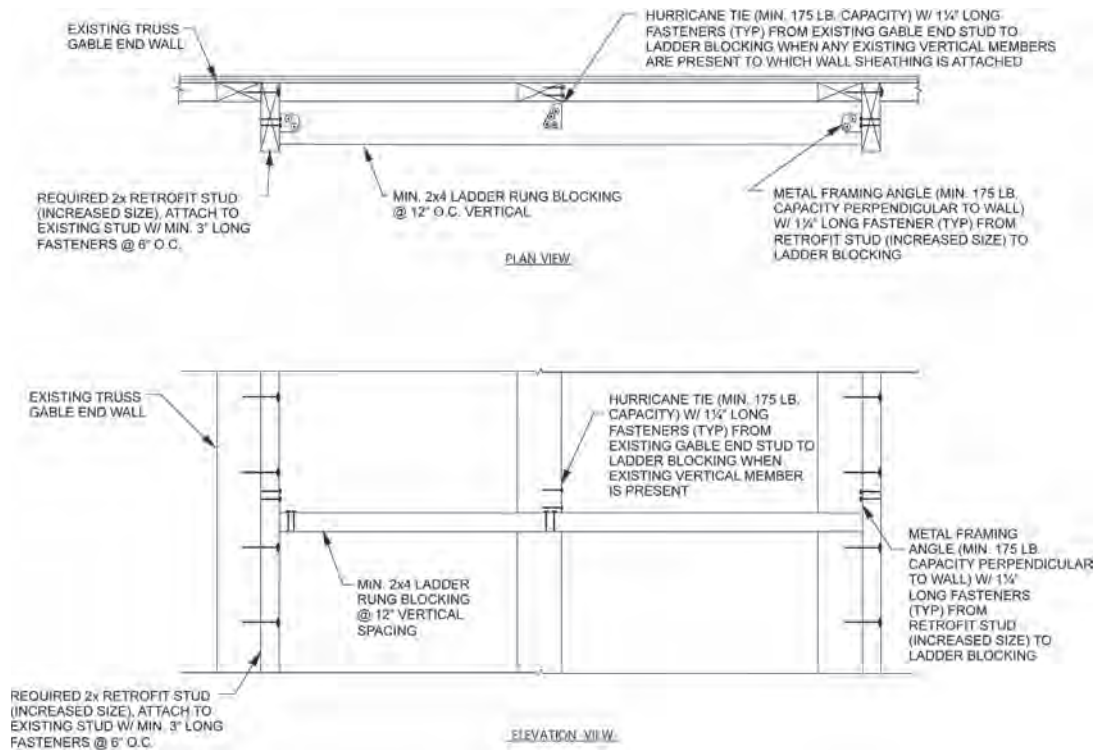

For SI: 1 inch = 25.4 mm, 1 pound = 4.4 N.

[BS] FIGURE C104.2.4(1)
LADDER BRACING FOR OMITTED RETROFIT STUD (GABLE END FRAME)

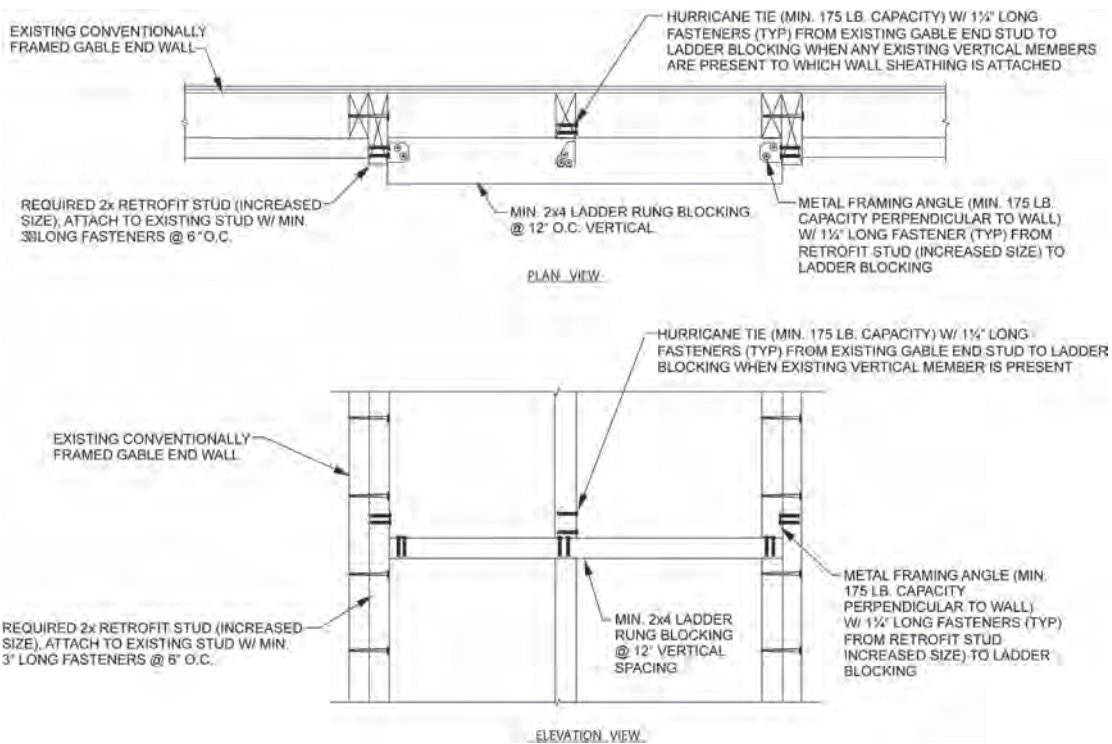

For SI: 1 inch = 25.4 mm, 1 pound = 4.4 N.

[BS] FIGURE C104.2.4(2)
LADDER BRACING FOR OMITTED RETROFIT STUD (CONVENTIONALLY FRAMED GABLE END)

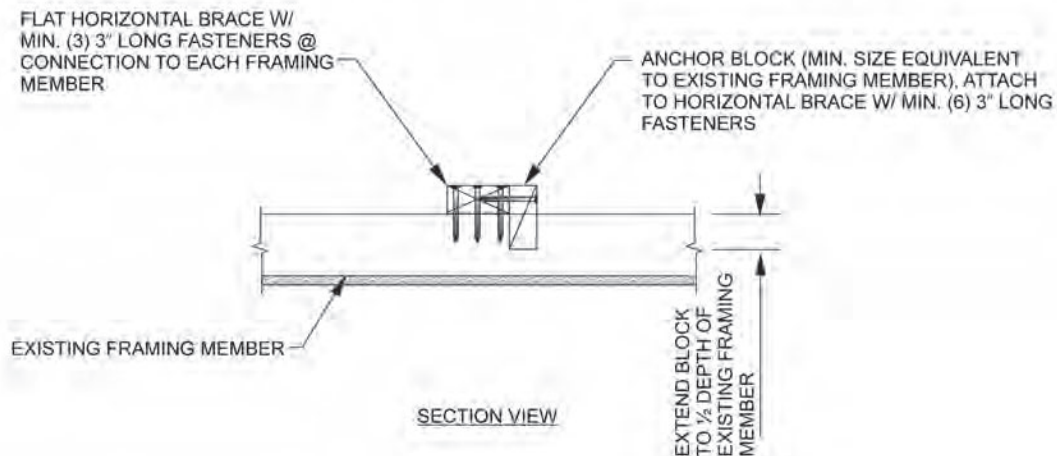
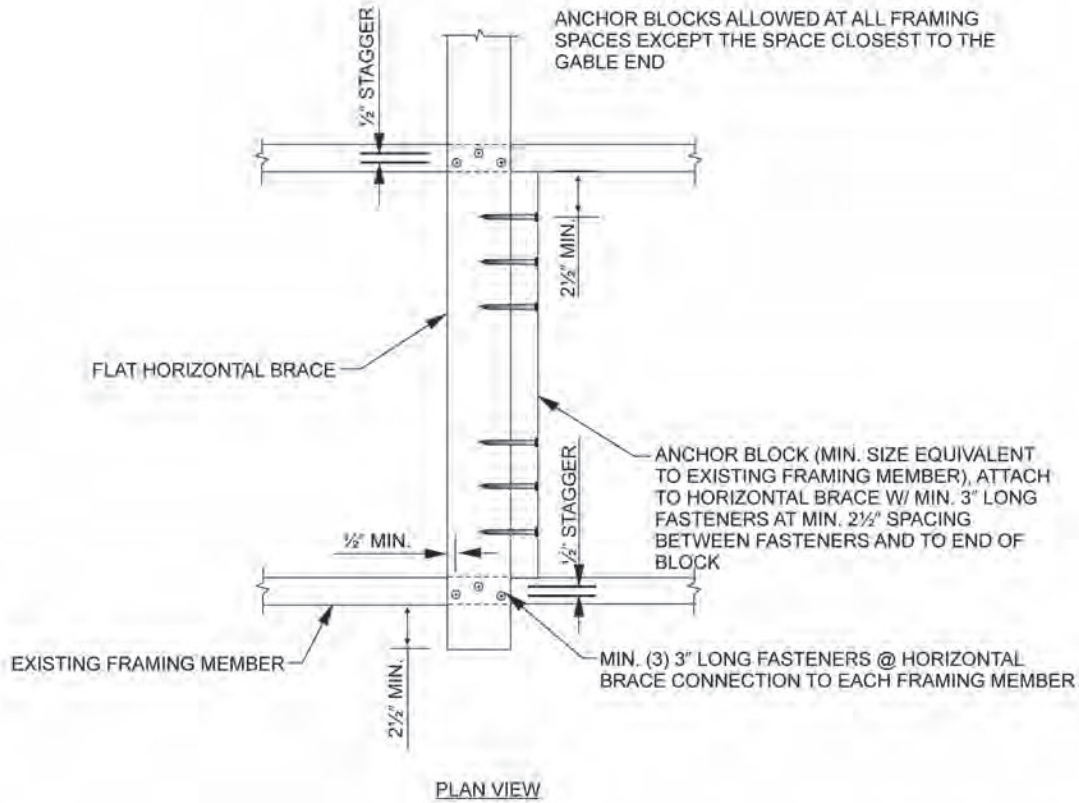

For SI: 1 inch = 25.4 mm.

[BS] FIGURE C104.2.5
ANCHOR BLOCK INSTALLATION

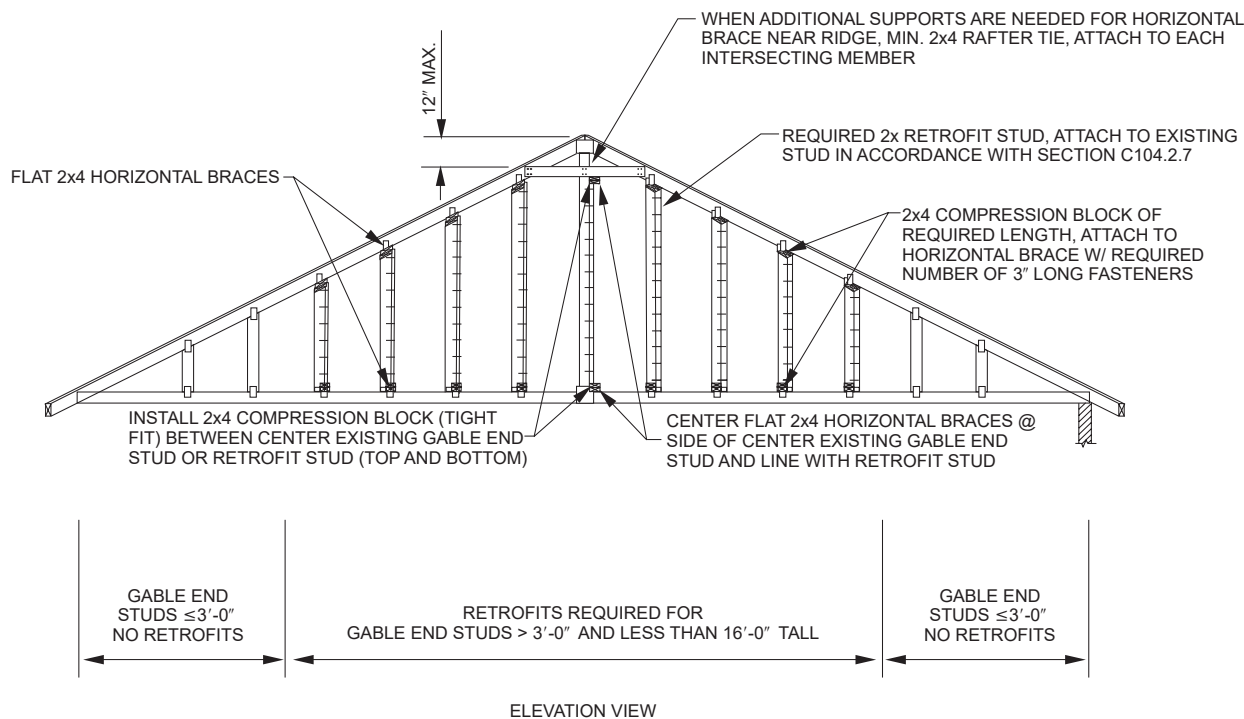

For SI: 1 inch = 25.4 mm, 1 foot = 304.8 mm.

**[BS] FIGURE C104.2.7
DETAIL OF RETROFIT TIE INSTALLATION**

For Condition 1 both the lower stud and the upper stud shall be retrofitted using the methods of Section C104.2. For Condition 2 the retrofit stud shall be connected to the lower studs using the methods of Section C104.2 and be continuous from the bottom horizontal brace to the top horizontal brace. Connection is not required between the retrofit stud and the upper stud. In both conditions the bottom chord of the piggyback truss section shall be fastened to each retrofit stud using a connector with minimum axial capacity of 175 pounds (778 N).

[BS] C104.3 Retrofit studs. Retrofit studs shall be installed in accordance with Section C104.3.1 using one of the five methods of Sections C104.3.2, C104.3.3, C104.3.4, C104.3.5 or C104.3.6. Figure C104.3 shows these methods of installation. For the Retrofit Configuration obtained from Table C104.2, the size of retrofit studs shall be as indicated in Table C104.4.1 or Table C104.4.2. Retrofit studs shall extend from the top of the lower horizontal brace to the bottom of the upper horizontal brace except that a maximum gap of $\frac{1}{8}$ inch (3.2 mm) is permitted at the bottom and $\frac{1}{2}$ inch (12.7 mm) at the top. Where wall sheathing, panel siding, or other wall covering is fastened to a conventionally framed gable end, retrofit studs shall be applied in accordance with Section C104.2.1.

[BS] C104.3.1 Fastening. Where nail plates are not used, retrofit studs shall be attached to existing studs using 3-inch (76 mm) fasteners at not greater than 6 inches (152 mm) on center but not closer than $2\frac{1}{2}$ inches (64 mm) on center with fasteners not closer to ends of members than $2\frac{1}{2}$ inches (64 mm).

[BS] C104.3.2 Method #1: Face-to-edge or face-to-face method. Retrofit studs shall be installed immediately adjacent to existing gable end wall studs as indicated in Figure C104.3(a). The retrofit studs shall overlap the edge or side of the existing stud by not less than $1\frac{1}{4}$ inches (32 mm). Fasteners shall be installed as specified in Section C104.3.1.

[BS] C104.3.3 Method #2: Face-to-face offset method. Retrofit studs shall be installed against the face of existing studs as indicated in Figure C104.3(b) such that the faces overlap not less than $1\frac{1}{2}$ inches (38 mm) and the edge distance to fasteners is not less than $\frac{3}{4}$ inch (19.1 mm). Fasteners shall be installed as specified in Section C104.3.1.

[BS] C104.3.4 Method #3: Butted retrofit stud method. Provided that all of the following fastening conditions are met, retrofit studs shall be permitted to be butted by their edge to existing studs with the addition of nail plates as indicated in Figure C104.3(c) and Figure C104.3.4.

1. The narrow edge of retrofit studs shall be installed against the narrow or the wide face of existing studs.
2. Not fewer than two nail plates shall be used.
3. Fasteners used to secure nail plates to studs shall be a minimum $1\frac{1}{4}$ inches (32 mm) long (#8 wood screws or 8d nails).
4. Fasteners placed in nail plates shall have a minimum end distance of $2\frac{1}{2}$ inches (64 mm) for both studs and a maximum end distance of 6 inches (152 mm) from the ends of the shorter stud.

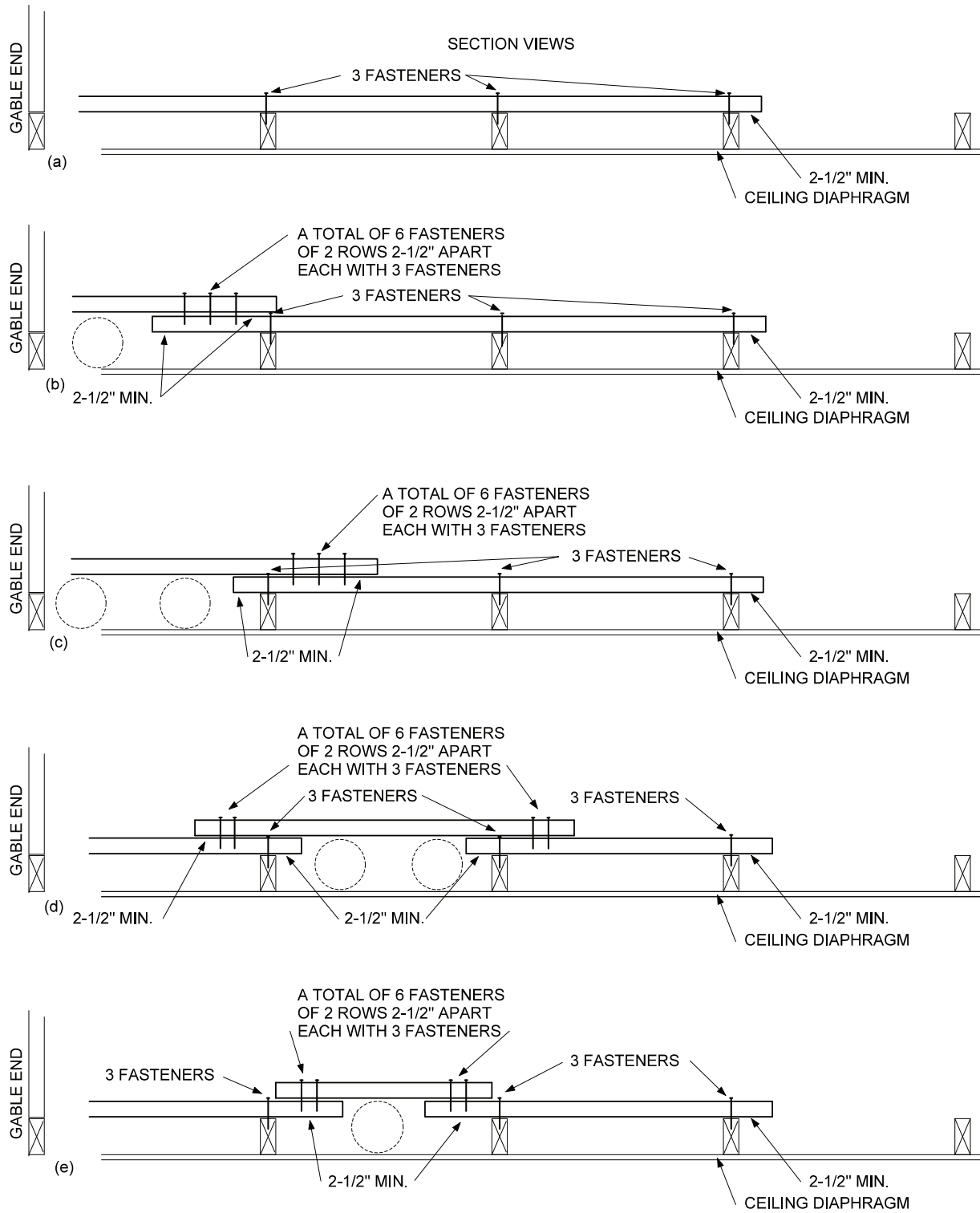

ALL FASTENERS 3"

For SI: 1 inch = 25.4 mm.

[BS] FIGURE C104.2.8(1)
SPLICED HORIZONTAL BRACES

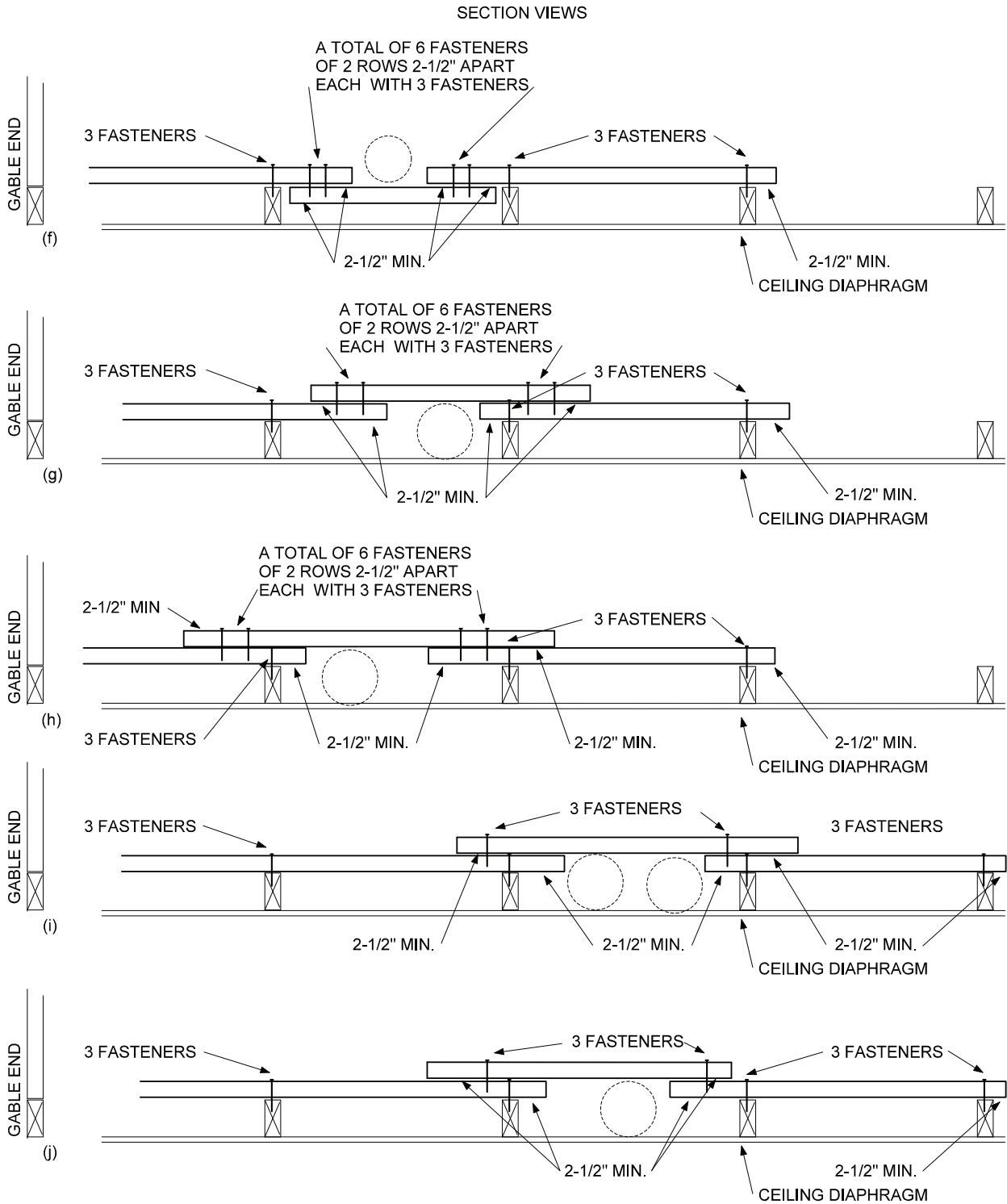

ALL FASTENERS 3"

For SI: 1 inch = 25.4 mm.

**[BS] FIGURE C104.2.8(2)
SPLICED HORIZONTAL BRACES**

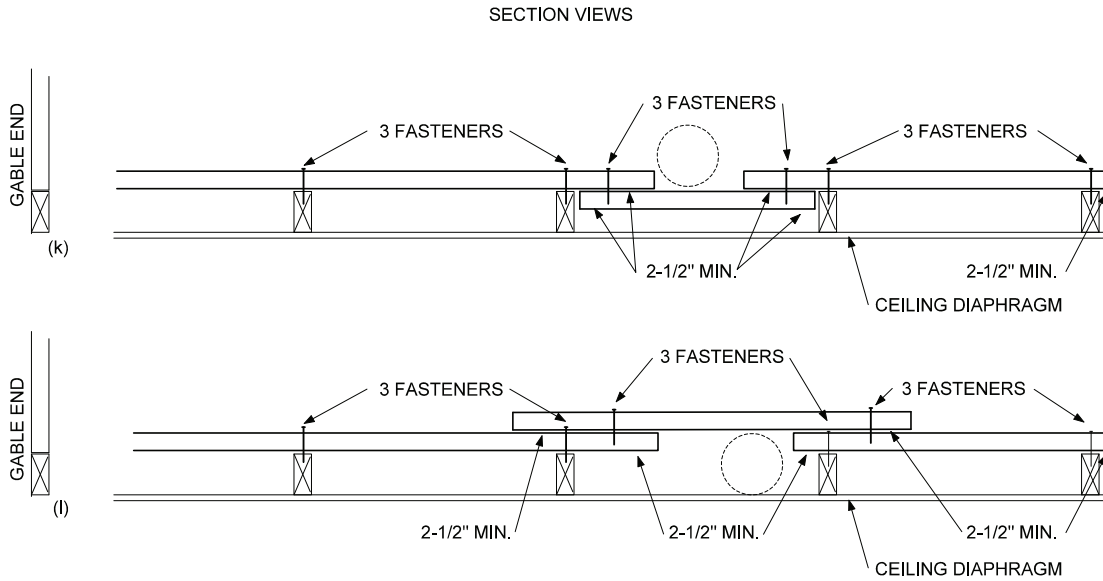

ALL FASTENERS 3"

For SI: 1 inch = 25.4 mm.

[BS] FIGURE C104.2.8(3)
SPLICED HORIZONTAL BRACES

5. Fasteners shall have a minimum $\frac{1}{2}$ -inch (12.7 mm) edge distance. Fasteners shall be placed not greater than $1\frac{1}{2}$ inches (38 mm) from the abutting vertical edges of existing studs and retrofit studs.
6. There shall be at least three fasteners through nail plates into all existing and retrofit studs to which the nail plate is attached.
7. Nail plates with three fasteners onto a single existing or retrofit stud shall be spaced not greater than 15 inches (38 cm) on center.
8. Nail plates with more than three fasteners onto a single existing or retrofit stud shall be spaced not greater than 20 inches (51 cm) on center.
9. Fasteners used to secure nail plates shall be spaced vertically not less than $1\frac{1}{2}$ inches (38 mm) on center. Staggered fasteners used to secure nail plates shall be spaced horizontally not less than $\frac{1}{2}$ inch (12.7 mm).

[BS] C104.3.5 Method #4: Offset retrofit stud method.

Retrofit studs may be offset from existing studs by use of nail plates as shown in Figure C104.3(d) such that the vertical corner of a retrofit stud shall align with the vertical corner of an existing stud as indicated in Figure C104.3(d) and Figure C104.3.4, and the fastening conditions of Section C104.3.4 are met.

[BS] C104.3.6 Method #5: Nailer with retrofit stud method. Retrofit studs and existing studs shall be permitted to be connected using noncontinuous 2-inch by 4-inch (38 mm by 89 mm) nailers as indicated in Figure C104.3(e) provided that the following conditions are met.

1. Both the existing stud and the retrofit stud shall be butted to nailers and both shall be fastened to the

nailer with 3-inch-long (76 mm) fasteners (#8 wood screws or 8d nails). Fasteners connecting each stud to the nailer shall be spaced 6 inches (152 mm) o.c.

2. Fasteners into nailers from any direction shall be offset vertically by not less than $2\frac{1}{2}$ inches (64 mm).
3. Fasteners into nailers shall be not less than $2\frac{1}{2}$ inches (64 mm) but not more than 6 inches (152 mm) from the end of the shorter of the existing stud and retrofit stud to which they are fastened.

[BS] C104.3.7 Reduced depth of retrofit studs. Retrofit studs may be reduced in depth by notching, tapering, or other methods at any number of locations along their length provided that all of the following conditions are met:

1. Retrofit studs to be reduced in depth shall be sized such that the remaining minimum depth of member at the location of the notch (including cross-cut kerfs) shall be not less than that required by Table C104.4.1 or C104.4.2.
2. Reduced in-depth retrofit stud shall not be spliced within 12 inches (30 cm) of the location of notches. Splice members shall not be notched.
3. The vertical extent of notches shall not exceed 12 inches (30 cm) as measured at the depth of location of reduced depth.
4. A reduced in-depth retrofit stud member shall be fastened to the side of the existing gable end wall studs in accordance with Section C104.3.1. Two additional 3-inch (76 mm) fasteners (#8 wood screws or 10d nails) shall be installed on each side of notches in addition to those required by Section C104.3.1.

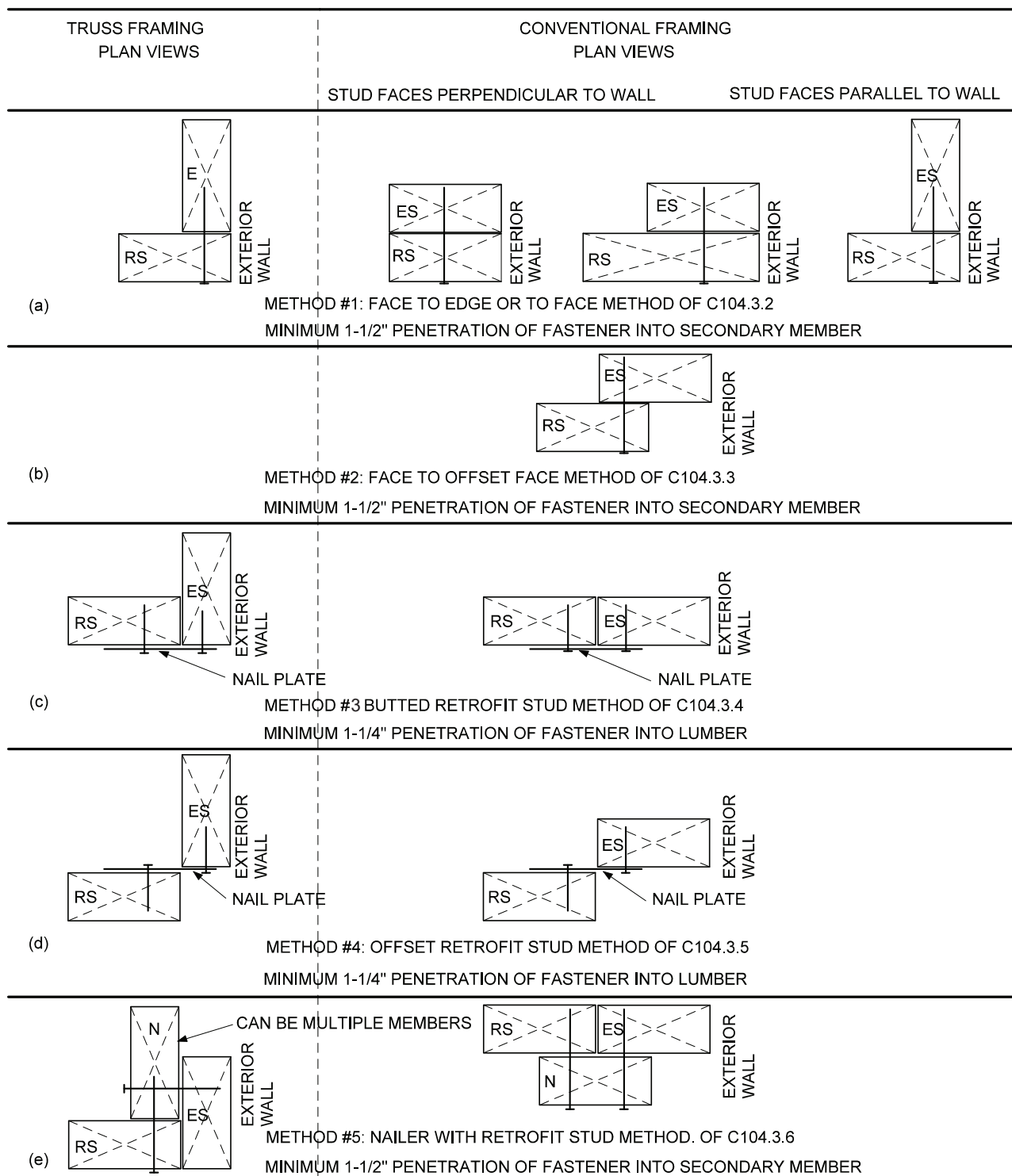

THE FIGURES DO NOT REFLECT THE NUMBER OF REQUIRED FASTENERS OR SHOW HORIZONTAL BRACES OR STRAPS. FASTENERS SHALL BE PLACED MAXIMUM 6" ON CENTER AND A MINIMUM OF 2-1/2" FROM ENDS. 3" FASTENERS CAN BE INSTALLED FROM EITHER SIDE OF LUMBER AS LONG AS THERE IS 1-1/2" FASTENER PENETRATION. ES INDICATES AN EXISTING STUD. RS INDICATES A RETROFIT STUD. N INDICATES A NAILER.

For SI: 1 inch = 25.4 mm.

[BS] FIGURE C104.3
METHOD OF INSTALLING RETROFIT STUDS

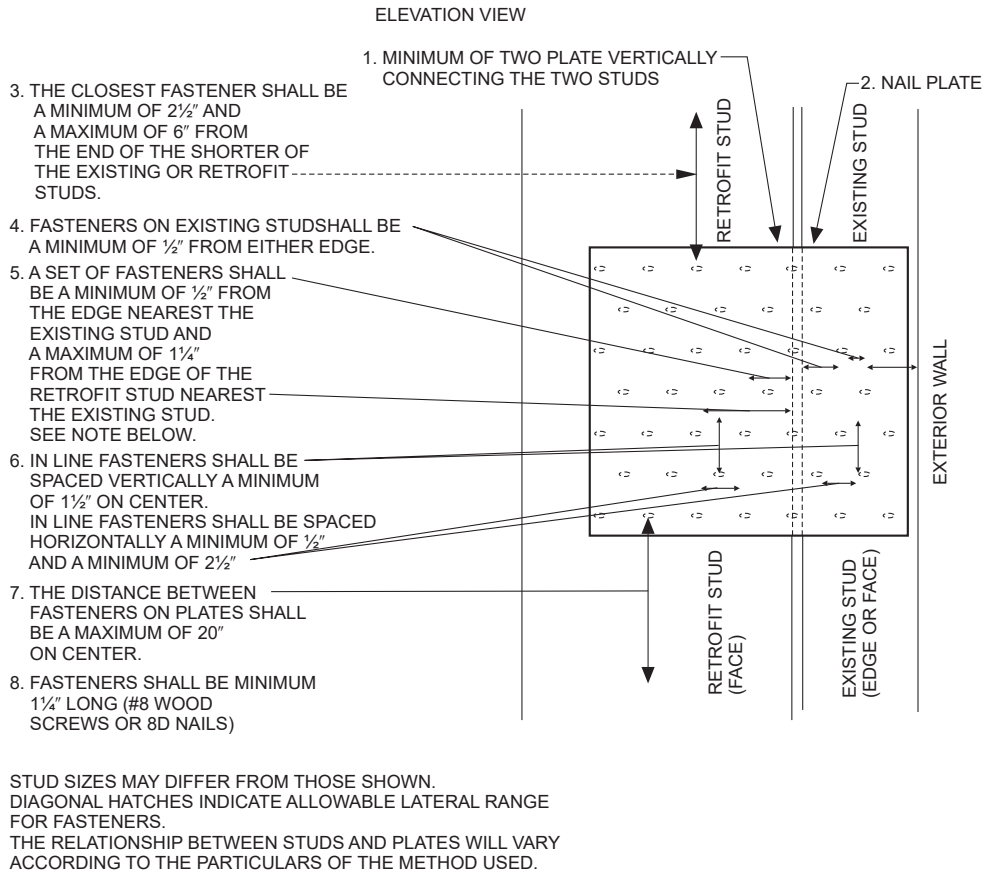

For SI: 1 inch = 25.4 mm.

**[BS]FIGURE C104.3.4
 NAIL PLATE FASTENING**

[BS] C104.3.8 Retrofit stud splices. Retrofit studs greater than 8 feet (244 cm) in height may be field spliced in accordance with Figure C104.3.8.

[BS] C104.4 Connection between horizontal braces and retrofit studs. Connections between horizontal braces and retrofit studs shall comply with Section C104.4.1 or C104.4.2. Each retrofit stud shall be connected to the top and bottom horizontal brace members with a minimum 20-gage 1 1/4-inch-wide (32 mm) flat or coil metal strap with prepunched holes for fasteners. Straps shall be fastened with 1 1/4-inch-long (32 mm) fasteners (#8 wood screws or 8d nails) with the number of fasteners as indicated in Tables C104.4.1 and C104.4.2. Fasteners shall be not closer to the end of lumber than 2 1/2 inches (64 mm).

[BS] C104.4.1 L-bent strap method. Retrofit studs shall be connected to horizontal braces or to strong backs in accordance with Figure C104.2(1), C104.2(2) or C104.2.3, and shall comply with the following conditions.

1. A strap shall be applied to the edges of a retrofit stud nearest the gable end wall and to the face of horizontal braces using at each end of the strap the number of fasteners specified in Table C104.4.1. Straps shall be long enough so that each strap extends sufficient distance onto the vertical face of the retrofit stud that

the fastener closest to the ends of the studs is not less than 2 1/2 inches (64 mm) from the end of the stud. Straps shall be permitted to be twisted to accommodate the transition between the tops of retrofit studs and horizontal bracings following roof pitches.

2. Compression blocks shall be installed on the horizontal braces directly against either the existing vertical gable end wall stud or the retrofit stud. Figure C104.2(1) (trusses) and Figure C104.2(2) (conventionally framed) show the installation of the compression block against the existing vertical gable end wall stud with the strap from the retrofit stud running beside the compression block. Compression blocks shall be permitted to be placed over straps. Compression blocks shall be fastened to the horizontal braces with not fewer than the minimum number of 3-inch-long (76 mm) fasteners (#8 wood screws or 10d nails) specified in Table C104.4.1. End and edge distances for fasteners shall be in accordance with Section C103.5.3.

[BS] C104.4.2 U-bent strap method. Retrofit studs shall be connected to horizontal braces in accordance with Figure C104.2(3) or C104.2(4), shall be limited to Retrofit

Configurations A and B as defined in Table C104.2, and shall comply with the following conditions.

1. Straps of sufficient length to meet the requirements for the number of fasteners in accordance with Table C104.2 and meet the end distance requirements of Section C103.5.3 shall be shaped around retrofit studs and fastened to the edges of horizontal braces. Straps shall wrap the back edge of the retrofit stud snugly with a maximum gap of 1/4 inch (6.4 mm). Rounded bends of straps shall be permitted.

2. The horizontal brace shall butt snugly against the retrofit stud with a maximum gap of 1/4 inch (6.4 mm).
3. Straps shall be permitted to be twisted to accommodate the transition between the tops of retrofit studs and horizontal braces that follow the roof pitch.

[BS] C104.5 Connection of gable end wall to wall below. The bottom chords or bottom members of wood-framed gable end walls shall be attached to the wall below using

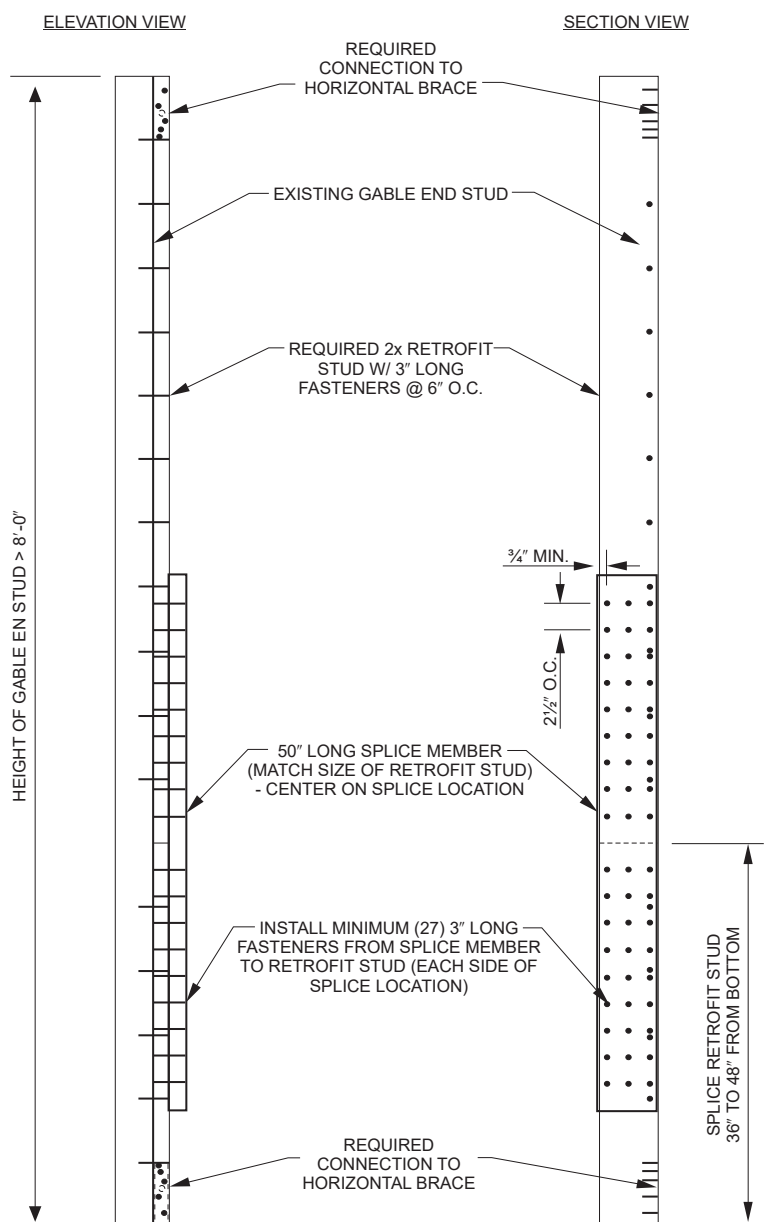

NOTE:
SPLICE LOCATION MAY BE REQUIRED AT TOP OF GABLE END STUD IF HEIGHT > 11'-0" TO 12'-0"

For SI: 1 inch = 25.4 mm, 1 foot = 304.8 mm.

**[BS] FIGURE C104.3.8
RETROFIT STUD SPLICES**

one of the methods prescribed in Sections C104.5.1 or C104.5.2. The particular method chosen shall correspond to the framing system and type of wall construction encountered.

[BS] C104.5.1 Gable end frame. The bottom chords of the gable end frame shall be attached to the wall below using gusset angles. Not fewer than two fasteners shall be installed into the bottom chord. The gusset angles shall be installed throughout the portion of the gable end where the gable end wall height is greater than 3 feet (91 cm) at the spacing specified in Table C104.5.1. Connection to the wall below shall be by one of the following methods:

1. For a wood-frame wall below, not fewer than two fasteners shall be installed. The fasteners shall be of the same diameter and style specified by the gusset angle manufacturer and sufficient length to extend through the double top plate of the wall below.
2. For a concrete or masonry wall below without a sill plate, the type and number of fasteners into the wall shall be consistent with the gusset angle manufacturer's specifications for fasteners installed in concrete or masonry.
3. For a concrete or masonry wall below with a 2x sill plate, the fasteners into the wall below shall be of the diameter and style specified by the gusset angle manufacturer for concrete or masonry connections; but, long enough to pass through the wood sill plate and provide the required embedment into the concrete or masonry below. Alternatively, the gusset angle can be anchored to the sill plate using four each 1½-inch-long (38 mm) fasteners of the same type as specified by the gusset angle manufacturer

for wood connections, provided that the sill plate is anchored to the wall on each side of the gusset angle by a ¼-inch-diameter (6.4 mm) masonry screw with 2¾ inches (70 mm) of embedment into the concrete or masonry wall. A ¼-inch (6.4 mm) washer shall be placed under the heads of the masonry screws.

[BS] C104.5.2 Conventionally framed gable end wall. Each stud in a conventionally framed gable end wall, throughout the length of the gable end wall where the wall height is greater than 3 feet (914 mm), shall be attached to the bottom or sill plate using a stud to plate connector with minimum uplift capacity of 175 pounds (778 N). The bottom or sill plate shall then be connected to the wall below using one of the following methods:

1. For a wood frame wall below, the sill or bottom plate shall be connected to the top plate of the wall below using ¼-inch-diameter (6.4 mm) lag bolt fasteners of sufficient length to penetrate the bottom plate of the upper gable end wall and extend through the bottom top plate of the wall below. A washer sized for the diameter of the lag bolt shall be placed under the head of each lag bolt. The fasteners shall be installed at the spacing indicated in Table C104.5.2.
2. For a concrete or masonry wall below, the sill or bottom plate shall be connected to the concrete or masonry wall below using ¼-inch-diameter (6.4 mm) concrete or masonry screws of sufficient length to provide 2¾ inches (70 mm) of embedment into the top of the concrete or masonry wall. A washer sized for the diameter of the lag bolt shall be placed under the head of each lag bolt. The fasteners shall be installed at the spacing indicated in Table C104.5.2.

**[BS] TABLE C104.4.1
ELEMENT SIZING AND SPACING FOR L-BENT RETROFIT METHOD**

RETROFIT ELEMENTS	RETROFIT CONFIGURATION			
	A	B	C	D
Minimum size and number of Horizontal Braces	2 x 4	2 x 4	2 x 4	2 each 2 x 4
Minimum size and number of Retrofit Studs	2 x 4	2 x 6	2 x 8	2 each 2 x 8
Minimum number of fasteners connecting each end of straps to Retrofit Studs or to Horizontal Braces #8 screws or 10d nails 1¼" long	6	9	12	8 on each strap
Minimum number of fasteners to connect Compression Blocks to Horizontal Braces #8 screws or 10d nails 3" long	6	8	10	12

For SI: 1 inch = 25.4 mm, 1 foot = 304.8 mm.

**[BS] TABLE C104.4.2
ELEMENT SIZING AND SPACING FOR U-BENT RETROFIT METHOD**

RETROFIT ELEMENTS	RETROFIT CONFIGURATION			
	A	B	C	D
Minimum size and number of Horizontal Braces	2 x 4	2 x 4	2 x 4	2 each 2 x 4
Minimum size and number of Retrofit Studs	2 x 4	2 x 6	2 x 8	2 each 2 x 8
Minimum number of fasteners connecting Straps to each edge of Horizontal Braces #8 screws or 10d nails 1¼" long	6	7	7	6 on each side of strap

For SI: 1 inch = 25.4 mm, 1 foot = 304.8 mm.

**[BS] TABLE C104.5.1
SPACING OF GUSSET ANGLES**

EXPOSURE CATEGORY	BASIC WIND SPEED (mph)	SPACING OF GUSSET ANGLES (inches)
C	140	38
C	150	32
C	165	28
C	180	24
C	190	20
B	140	48
B	150	40
B	165	36
B	180	30
B	190	26

For SI: 1 inch = 25.4 mm, 1 mile per hour = 0.447 m/s.

**[BS] TABLE C104.5.2
SPACING OF LAG OR MASONRY SCREWS USED TO CONNECT SILL PLATE OF GABLE END WALL TO TOP OF THE WALL BELOW**

EXPOSURE CATEGORY	BASIC WIND SPEED (mph)	SPACING OF LAG OR MASONRY SCREWS (inches)
C	140	19
C	150	16
C	165	14
C	180	14
C	190	10
B	140	24
B	150	20
B	165	18
B	180	15
B	190	13

For SI: 1 inch = 25.4 mm, 1 mile per hour = 0.447 m/s.

CHAPTER C2

ROOF DECK FASTENING FOR HIGH-WIND AREAS

SECTION C201 GENERAL

[BS] C201.1 Purpose. This chapter provides prescriptive methods for partial structural retrofit of an *existing building* to increase its resistance to wind loads. It is intended for voluntary use where the ultimate design wind speed, V_{ult} , determined in accordance with Figure 1609.3(1) of the *International Building Code* exceeds 130 mph (58 m/s) and for reference by mitigation programs. The provisions of this chapter do not necessarily satisfy requirements for new construction. Unless specifically cited, the provisions of this chapter do not necessarily satisfy requirements for structural improvements triggered by *addition, alteration, repair, change of occupancy*, building relocation or other circumstances.

[BS] C201.2 Eligible conditions. The provisions of this chapter are applicable only to buildings that meet either of the following eligibility requirements:

1. Buildings assigned to *Risk Category I* or *II* in accordance with *International Building Code* Table 1604.5.
2. Buildings within the scope of the *International Residential Code*.

SECTION C202 ROOF DECK ATTACHMENT FOR WOOD ROOFS

[BS] C202.1 Roof decking attachment for one- and two-family dwellings. For one- and two-family dwellings, fastening shall be in accordance with Section C202.1.1 or C202.1.2 as appropriate for the existing construction. The diameter of 8d nails shall be not less than 0.131 inch (3 mm) and the length shall be not less than $2\frac{1}{4}$ inches (57 mm) to qualify for the provisions of this section for existing nails regardless of head shape or head diameter.

[BS] C202.1.1 Sawn lumber or wood plank roofs. Roof decking consisting of sawn lumber or wood planks up to 12 inches (30 cm) wide and secured with not fewer than two nails (minimum size 8d) to each roof framing member it crosses shall be deemed to be sufficiently connected.

Sawn lumber or wood plank decking secured with smaller fasteners than 8d nails or with fewer than two nails (minimum size 8d) to each framing member it crosses shall be deemed sufficiently connected if fasteners are added such that two clipped head, round head or ring shank nails (minimum size 8d) are in place on each framing member the nail crosses.

[BS] C202.1.2 Wood structural panel roofs. For roof decking consisting of wood structural panels, fasteners and spacings required in Table C202.1.2 shall be deemed to comply with the requirements of Section 707.3 of the *International Existing Building Code*.

Supplemental fasteners as required by Table C202.1.2 shall be 8d ring shank nails with round heads and the following minimum dimensions:

1. 0.113-inch-nominal (3 mm) shank diameter.
2. Ring diameter not less than 0.012 inch (0.3 mm) greater than shank diameter.
3. 16 to 20 rings per inch.
4. A minimum 0.280-inch (7 mm) full round head diameter.
5. Ring shank to extend not less than $1\frac{1}{2}$ inches (38 mm) from the tip of the nail.
6. Minimum $2\frac{1}{4}$ -inch (57 mm) nail length.

SECTION C203 REFERENCED STANDARDS

IBC—18	<i>International Building Code</i> [®]	C101.3, C103.2, C201.1, C201.2
IEBC—18	<i>International Existing Building Code</i> [®]	C202.1.2
IRC—18	<i>International Residential Code</i> [®]	C101.2, C101.3, C103.2, C201.2

[BS] TABLE C202.1.2
SUPPLEMENT FASTENERS AT PANEL EDGES AND INTERMEDIATE FRAMING

EXISTING FASTENERS	EXISTING FASTENER SPACING (EDGE OR INTERMEDIATE SUPPORTS)	MAXIMUM SUPPLEMENTAL FASTENER SPACING FOR 130 MPH < V_{ult} ≤ 140 MPH	MAXIMUM SUPPLEMENTAL FASTENER SPACING FOR INTERIOR ZONE ^c LOCATIONS FOR MPH V_{ult} > 140 MPH AND EDGE ZONES NOT COVERED BY THE COLUMN TO THE RIGHT	EDGE ZONE ^d FOR V_{ult} > 160 MPH AND EXPOSURE C, OR V_{ult} > 180 MPH AND EXPOSURE B
Staples or 6d	Any	6" o.c. ^b	6" o.c. ^b	4" o.c. ^b at panel edges and 4" o.c. ^b at intermediate supports
8d clipped head or round head smooth shank	6" o.c. or less	None necessary	None necessary along edges of panels but 6" o.c. ^b at intermediate supports of panel	4" o.c. ^a at panel edges and 4" o.c. ^a at intermediate supports
8d clipped head or round head ring shank	6" o.c. or less	None necessary	None necessary	4" o.c. ^a at panel edges and 4" o.c. ^a at intermediate supports
8d clipped head or round head smooth shank	Greater than 6" o.c.	6" o.c. ^a	6" o.c. ^a along panel edges and 6" o.c. ^b at intermediate supports of panel	4" o.c. ^a at panel edges and 4" o.c. ^a at intermediate supports
8d clipped head or round head ring shank	Greater than 6" o.c.	6" o.c. ^a	6" o.c. ^a	4" o.c. ^a at panel edges and 4" o.c. ^a at intermediate supports

For SI: 1 inch = 25.4 mm; 1 foot = 304.8 mm; 1 mile per hour = 0.447 m/s.

- a. Maximum spacing determined based on existing fasteners and supplemental fasteners.
- b. Maximum spacing determined based on supplemental fasteners only.
- c. Interior zone = sheathing that is not located within 4 feet of the perimeter edge of the roof or within 4 feet of each side of a ridge.
- d. Edge zone = sheathing that is located within 4 feet of the perimeter edge of the roof and within 4 feet of each side of a ridge.

RESOURCE A

GUIDELINES ON FIRE RATINGS OF ARCHAIC MATERIALS AND ASSEMBLIES

User note:

About this resource: *In the process of repair and alteration of existing buildings, based on the nature and the extent of the work, this code might require certain upgrades in the fire-resistance rating of building elements, at which time it becomes critical for the designers and the code officials to be able to determine the fire-resistance rating of the existing building elements as part of the overall evaluation for the assessment of the need for improvements. This resource document provides a guideline for such an evaluation for fire-resistance rating of archaic materials that is not typically found in the modern model building codes.*

Introduction

The *International Existing Building Code*® (IEBC®) is a comprehensive code with the goal of addressing all aspects of work taking place in existing buildings and providing user-friendly methods and tools for regulation and improvement of such buildings. This resource document is included within the cover of the IEBC with that goal in mind and as a step towards accomplishing that goal.

In the process of *repair* and *alteration* of existing buildings, based on the nature and the extent of the work, the IEBC might require certain upgrades in the fire-resistance rating of building elements, at which time it becomes critical for the designers and the code officials to be able to determine the fire-resistance rating of the *existing building* elements as part of the overall evaluation for the assessment of the need for improvements. This resource document provides a guideline for such an evaluation for fire-resistance ratings of archaic materials that are not typically found in the modern model building codes.

Resource A is only a guideline and is not intended to be a document for specific adoption as it is not written in the format or language of ICC's *International Codes* and is not subject to the code development process.

PURPOSE

The *Guideline on Fire Ratings of Archaic Materials and Assemblies* focuses upon the fire-related performance of archaic construction. "Archaic" encompasses construction typical of an earlier time, generally prior to 1950. "Fire-related performance" includes fire resistance, flame spread, smoke production and degree of combustibility.

The purpose of this guideline is to update the information which was available at the time of original construction, for use by architects, engineers and code officials when evaluating the fire safety of a rehabilitation project. In addition, information relevant to the evaluation of general classes of materials and types of construction is presented for those cases when documentation of the fire performance of a particular archaic material or assembly cannot be found.

It has been assumed that the building materials and their fastening, joining and incorporation into the building structure are sound mechanically. Therefore, some determination must be made that the original manufacture, the original construction practice, and the rigors of aging and use have not weakened the building. This assessment can often be difficult because process and quality control was not good in many industries, and variations among locally available raw materials and manufacturing techniques often resulted in a product which varied widely in its strength and durability. The properties of iron and steel, for example, varied widely, depending on the mill and the process used.

There is nothing inherently inferior about archaic materials or construction techniques. The pressures that promote fundamental change are most often economic or technological matters not necessarily related to concerns for safety. The high cost of labor made wood lath and plaster uneconomical. The high cost of land and the congestion of the cities provided the impetus for high-rise construction. Improved technology made it possible. The difficulty with archaic materials is not a question of suitability, but familiarity.

Code requirements for the fire performance of key building elements (e.g., walls, floor/ceiling assemblies, doors, shaft enclosures) are stated in performance terms: hours of fire resistance. It matters not whether these elements were built in 1908 or 1980, only that they provide the required degree of fire resistance. The level of performance will be defined by the local community, primarily through the enactment of a building or rehabilitation code. This guideline is only a tool to help evaluate the various building elements, regardless of what the level of performance is required to be.

The problem with archaic materials is simply that documentation of their fire performance is not readily available. The application of engineering judgment is more difficult because building officials may not be familiar with the materials or construction

method involved. As a result, either a full-scale fire test is required or the archaic construction in question removed and replaced. Both alternatives are time consuming and wasteful.

This guideline and the accompanying appendix are designed to help fill this information void. By providing the necessary documentation, there will be a firm basis for the continued acceptance of archaic materials and assemblies.

1 FIRE-RELATED PERFORMANCE OF ARCHAIC MATERIALS AND ASSEMBLIES

1.1 FIRE PERFORMANCE MEASURES

This guideline does not specify the level of performance required for the various building components. These requirements are controlled by the building occupancy and use and are set forth in the local building or rehabilitation code.

The fire resistance of a given building element is established by subjecting a sample of the assembly to a “standard” fire test which follows a “standard” time-temperature curve. This test method has changed little since the 1920s. The test results tabulated in the Appendix have been adjusted to reflect current test methods.

The current model building codes cite other fire-related properties not always tested for in earlier years: flame spread, smoke production, and degree of combustibility. However, they can generally be assumed to fall within well defined values because the principal combustible component of archaic materials is cellulose. Smoke production is more important today because of the increased use of plastics. However, the early flame spread tests, developed in the early 1940s, also included a test for smoke production.

“Plastics,” one of the most important classes of contemporary materials, were not found in the review of archaic materials. If plastics are to be used in a rehabilitated building, they should be evaluated by contemporary standards. Information and documentation of their fire-related properties and performance is widely available.

Flame spread, smoke production and degree of combustibility are discussed in detail below. Test results for eight common species of lumber, published in an Underwriter’s Laboratories’ report (104), are noted in the following table:

TUNNEL TEST RESULTS FOR EIGHT SPECIES OF LUMBER

SPECIES OF LUMBER	FLAME SPREAD	FUEL CONTRIBUTED	SMOKE DEVELOPED
Western White Pine	75	50-60	50
Northern White Pine	120-215	120-140	60-65
Ponderosa Pine	80-215	120-135	100-110
Yellow Pine	180-190	130-145	275-305
Red Gum	140-155	125-175	40-60
Yellow Birch	105-110	100-105	45-65
Douglas Fir	65-100	50-80	10-100

Flame Spread

The flame spread of interior finishes is most often measured by the ASTM E84 “tunnel test.” This test measures how far and how fast the flames spread across the surface of the test sample. The resulting flame spread rating (FSR) is expressed as a number on a continuous scale where cement-asbestos board is 0 and red oak is 100. (Materials with a flame spread greater than red oak have an FSR greater than 100.) The scale is divided into distinct groups or classes. The most commonly used flame spread classifications are: Class I or A*, with a 0-25 FSR; Class II or B, with a 26-75 FSR; and Class III or C, with a 76-200 FSR. The *NFPA Life Safety Code* also has a Class D (201-500 FSR) and Class E (over 500 FSR) interior finish.

These classifications are typically used in modern building codes to restrict the rate of fire spread. Only the first three classifications are normally permitted, though not all classes of materials can be used in all places throughout a building. For example, the interior finish of building materials used in exits or in corridors leading to exits is more strictly regulated than materials used within private dwelling units.

In general, inorganic archaic materials (e.g., bricks or tile) can be expected to be in Class I. Materials of whole wood are mostly Class II. Whole wood is defined as wood used in the same form as sawn from the tree. This is in contrast to the contemporary reconstituted wood products such as plywood, fiberboard, hardboard, or particle board. If the organic archaic material is not whole wood, the flame spread classification could be well over 200 and thus would be particularly unsuited for use in exits and other critical locations in a building. Some plywoods and various wood fiberboards have flame spreads over 200. Although they can be treated with fire retardants to reduce their flame spread, it would be advisable to assume that all such products have a flame spread over 200 unless there is information to the contrary.

Smoke Production

The evaluation of smoke density is part of the ASTM E84 tunnel test. For the eight species of lumber shown in the table above, the highest levels are 275-305 for Yellow Pine, but most of the others are less smoky than red oak which has an index of 100. The advent of plastics caused substantial increases in the smoke density values measured by the tunnel test. The ensuing limitation of the smoke production for wall and ceiling materials by the model building codes has been a reaction to the introduction of plastic materials. In general, cellulosic materials fall in the 50-300 range of smoke density which is below the general limitation of 450 adopted by many codes.

Degree of Combustibility

The model building codes tend to define “noncombustibility” on the basis of having passed ASTM E136 or if the material is totally inorganic. The acceptance of gypsum wallboard as noncombustible is based on limiting paper thickness to not over 1/8 inch and a 0-50 flame spread rating by ASTM E84. At times there were provisions to define a Class I or A mate-

rial (0-25 FSR) as noncombustible, but this is not currently recognized by most model building codes.

If there is any doubt whether or not an archaic material is noncombustible, it would be appropriate to send out samples for evaluation. If an archaic material is determined to be noncombustible according to ASTM E136, it can be expected that it will not contribute fuel to the fire.

* Some codes are Roman numerals, others use letters.

1.2 COMBUSTIBLE CONSTRUCTION TYPES

One of the earliest forms of timber construction used exterior load-bearing masonry walls with columns and/or wooden walls supporting wooden beams and floors in the interior of the building. This form of construction, often called “mill” or “heavy timber” construction, has approximately 1 hour fire resistance. The exterior walls will generally contain the fire within the building.

With the development of dimensional lumber, there was a switch from heavy timber to “balloon frame” construction. The balloon frame uses load-bearing exterior wooden walls which have long timbers often extending from foundation to roof. When longer lumber became scarce, another form of construction, “platform” framing, replaced the balloon framing. The difference between the two systems is significant because platform framing is automatically fire-blocked at every floor while balloon framing commonly has concealed spaces that extend unblocked from basement to attic. The architect, engineer, and *code official* must be alert to the details of construction and the ease with which fire can spread in concealed spaces.

2 BUILDING EVALUATION

A given rehabilitation project will most likely go through several stages. The preliminary evaluation process involves the designer in surveying the prospective building. The fire resistance of *existing building* materials and construction systems is identified; potential problems are noted for closer study. The final evaluation phase includes: developing design solutions to upgrade the fire resistance of building elements, if necessary; preparing working drawings and specifications; and the securing of the necessary code approvals.

2.1 PRELIMINARY EVALUATION

A preliminary evaluation should begin with a building survey to determine the existing materials, the general arrangement of the structure and the use of the occupied spaces, and the details of construction. The designer needs to know “what is there” before a decision can be reached about what to keep and what to remove during the rehabilitation process. This preliminary evaluation should be as detailed as necessary to make initial plans. The fire-related properties need to be

determined from the applicable building or rehabilitation code, and the materials and assemblies existing in the building then need to be evaluated for these properties. Two work sheets are shown below to facilitate the preliminary evaluation.

Two possible sources of information helpful in the preliminary evaluation are the original building plans and the building code in effect at the time of original construction. Plans may be on file with the local building department or in the offices of the original designers (e.g., architect, engineer) or their successors. If plans are available, the investigator should verify that the building was actually constructed as called for in the plans, as well as incorporate any later alterations or changes to the building. Earlier editions of the local building code should be on file with the building official. The code in effect at the time of construction will contain fire performance criteria. While this is no guarantee that the required performance was actually provided, it does give the investigator some guidance as to the level of performance which may be expected. Under some code administration and enforcement systems, the code in effect at the time of construction also defines the level of performance that must be provided at the time of rehabilitation.

Figure 1 illustrates one method for organizing preliminary field notes. Space is provided for the materials, dimensions, and condition of the principal building elements. Each floor of the structure should be visited and the appropriate information obtained. In practice, there will often be identical materials and construction on every floor, but the exception may be of vital importance. A schematic diagram should be prepared of each floor showing the layout of exits and hallways and indicating where each element described in the field notes fits into the structure as a whole. The exact arrangement of interior walls within apartments is of secondary importance from a fire safety point of view and need not be shown on the drawings unless these walls are required by code to have a fire resistance rating.

The location of stairways and elevators should be clearly marked on the drawings. All exterior means of escape (e.g., fire escapes) should be identified.¹

The following notes explain the entries in Figure 1.

Exterior Bearing Walls: Many old buildings utilize heavily constructed walls to support the floor/ceiling assemblies at the exterior of the building. There may be columns and/or interior bearing walls within the structure, but the exterior walls are an important factor in assessing the fire safety of a building.

The field investigator should note how the floor/ceiling assemblies are supported at the exterior of the building. If columns are incorporated in the exterior walls, the walls may be considered nonbearing.

Interior Bearing Walls: It may be difficult to determine whether or not an interior wall is load bearing, but the field investigator should attempt to make this determination. At a later stage of the rehabilitation process, this question will

1. Problems providing adequate exiting are discussed at length in the *Egress Guideline for Residential Rehabilitation*.

RESOURCE A

need to be determined exactly. Therefore, the field notes should be as accurate as possible.

Exterior Nonbearing Walls: The fire resistance of the exterior walls is important for two reasons. These walls (both bearing and nonbearing) are depended upon to: a) contain a fire within the building of origin; or b) keep an exterior fire *outside* the building. It is therefore important to indicate on the drawings where any openings are located as well as the materials and construction of all doors or shutters. The drawings should indicate the presence of wired glass, its thickness and framing, and identify the materials used for windows and door frames. The protection of openings adjacent to exterior means of escape (e.g., exterior stairways, fire escapes) is particularly important. The ground floor drawing should locate the building on the property and indicate the precise distances to adjacent buildings.

Interior Nonbearing Walls (Partitions): A partition is a “wall that extends from floor to ceiling and subdivides space within any story of a building.” (48) Figure 1 has two categories (A & B) for Interior Nonbearing Walls (Partitions) which can be used for different walls, such as hallway walls as compared to inter-apartment walls. Under some circumstances there may be only one type of wall construction; in others, three or more types of wall construction may occur.

The field investigator should be alert for differences in function as well as in materials and construction details. In general, the details within apartments are not as important as the major exit paths and exit stairways. The preliminary field investigation should attempt to determine the thickness of all walls. A term introduced below called “thickness design” will depend on an accurate ($\pm 1/4$ inch) determination. Even though this initial field survey is called “preliminary,” the

data generated should be as accurate and complete as possible.

The field investigator should note the exact location from which observations are recorded. For instance, if a hole is found through a wall enclosing an exit stairway which allows a cataloguing of the construction details, the field investigation notes should reflect the location of the “find.” At the preliminary stage it is not necessary to core every wall; the interior details of construction can usually be determined at some location.

Structural Frame: There may or may not be a complete skeletal frame, but usually there are columns, beams, trusses, or other like elements. The dimensions and spacing of the structural elements should be measured and indicated on the drawings. For instance, if there are 10-inch square columns located on a 30-foot square grid throughout the building, this should be noted. The structural material and cover or protective materials should be identified wherever possible. The thickness of the cover materials should be determined to an accuracy of $\pm 1/4$ inch. As discussed above, the preliminary field survey usually relies on accidental openings in the cover materials rather than a systematic coring technique.

Floor/Ceiling Structural Systems: The span between supports should be measured. If possible, a sketch of the cross-section of the system should be made. If there is no location where accidental damage has opened the floor/ceiling construction to visual inspection, it is necessary to make such an opening. An evaluation of the fire resistance of a floor/ceiling assembly requires detailed knowledge of the materials and their arrangement. Special attention should be paid to the cover on structural steel elements and the condition of suspended ceilings and similar membranes.

**FIGURE 1
PRELIMINARY EVALUATION FIELD NOTES**

BUILDING ELEMENT		MATERIALS	THICKNESS	CONDITION	NOTES
Exterior Bearing Walls					
Interior Bearing Walls					
Exterior Nonbearing Walls					
Interior Nonbearing Walls or Partitions:	A				
	B				
Structural Frame:					
Columns					
Beams					
Other					
Floor/Ceiling Structural System					
Spanning					
Roofs					
Doors (including frame and hardware):					
a) Enclosed vertical exitway					
b) Enclosed horizontal exitway					
c) Other					

Roofs: The preliminary field survey of the roof system is initially concerned with water-tightness. However, once it is apparent that the roof is sound for ordinary use and can be retained in the rehabilitated building, it becomes necessary to evaluate the fire performance. The field investigator must measure the thickness and identify the types of materials which have been used. Be aware that there may be several layers of roof materials.

Doors: Doors to stairways and hallways represent some of the most important fire elements to be considered within a building. The uses of the spaces separated largely controls the level of fire performance necessary. Walls and doors enclosing stairways or elevator shafts would normally require a higher level of performance than between the bedroom and bath. The various uses are differentiated in Figure 1.

Careful measurements of the thickness of door panels must be made, and the type of core material within each door must be determined. It should be noted whether doors have self-closing devices; the general operation of the doors should be checked. The latch should engage and the door should fit tightly in the frame. The hinges should be in good condition. If glass is used in the doors, it should be identified as either plain glass or wired glass mounted in either a wood or steel frame.

Materials: The field investigator should be able to identify ordinary building materials. In situations where an unfamiliar material is found, a sample should be obtained. This sample should measure at least 10 cubic inches so that an ASTM E136 fire test can be conducted to determine if it is combustible.

Thickness: The thickness of all materials should be measured accurately since, under certain circumstances, the level of fire resistance is very sensitive to the material thickness.

Condition: The method of attaching the various layers and facings to one another or to the supporting structural element should be noted under the appropriate building element. The “secureness” of the attachment and the general condition of the layers and facings should be noted here.

Notes: The “Notes” column can be used for many purposes, but it might be a good idea to make specific references to other field notes or drawings.

After the building survey is completed, the data collected must be analyzed. A suggested work sheet for organizing this information is given below as Figure 2.

The required fire resistance and flame spread for each building element are normally established by the local building or rehabilitation code. The fire performance of the existing materials and assemblies should then be estimated, using

**FIGURE 2
PRELIMINARY EVALUATION WORKSHEET**

BUILDING ELEMENT		REQUIRED FIRE RESISTANCE	REQUIRED FLAME SPREAD	ESTIMATED FIRE RESISTANCE	ESTIMATED FLAME SPREAD	METHOD OF UPGRADING	ESTIMATED UPGRADED PROTECTION	NOTES
Exterior Bearing Walls								
Interior Bearing Walls								
Exterior Nonbearing Walls								
Interior Nonbearing Walls or Partitions:	A							
	B							
Structural Frame: Columns								
Beams								
Other								
Floor/Ceiling Structural System Spanning								
Roofs								
Doors (including frame and hardware):								
a) Enclosed vertical exitway								
b) Enclosed horizontal exitway								
c) Others								

one of the techniques described below. If the fire performance of the *existing building* element(s) is equal to or greater than that required, the materials and assemblies may remain. If the fire performance is less than required, then corrective measures must be taken.

The most common methods of upgrading the level of protection are to either remove and replace the *existing building* element(s) or to *repair* and upgrade the existing materials and assemblies. Other fire protection measures, such as automatic sprinklers or detection and alarm systems, also could be considered, though they are beyond the scope of this guideline. If the upgraded protection is still less than that required or deemed to be acceptable, additional corrective measures must be taken. This process must continue until an acceptable level of performance is obtained.

2.2 FIRE RESISTANCE OF EXISTING BUILDING ELEMENTS

The fire resistance of the *existing building* elements can be estimated from the tables and histograms contained in the Appendix. The Appendix is organized first by type of building element: walls, columns, floor/ceiling assemblies, beams, and doors. Within each building element, the tables are organized by type of construction (e.g., masonry, metal, wood frame), and then further divided by minimum dimensions or thickness of the building element.

A histogram precedes every table that has 10 or more entries. The X-axis measures fire resistance in hours; the Y-axis shows the number of entries in that table having a given level of fire resistance. The histograms also contain the location of each entry within that table for easy cross-referencing.

The histograms, because they are keyed to the tables, can speed the preliminary investigation. For example, Table 1.3.2, *Wood Frame Walls 4" to Less Than 6" Thick*, contains 96 entries. Rather than study each table entry, the histogram shows that every wall assembly listed in that table has a fire resistance of less than 2 hours. If the building code required the wall to have 2 hours fire resistance, the designer, with a minimum of effort, is made aware of a problem that requires closer study.

Suppose the code had only required a wall of 1 hour fire resistance. The histogram shows far fewer complying elements (19) than noncomplying ones (77). If the existing assembly is not one of the 19 complying entries, there is a strong possibility the existing assembly is deficient. The histograms can also be used in the converse situation. If the existing assembly is not one of the smaller number of entries with a lower than required fire resistance, there is a strong possibility the existing assembly will be acceptable.

At some point, the *existing building* component or assembly must be located within the tables. Otherwise, the fire resistance must be determined through one of the other techniques presented in the guideline. Locating the building component in the Appendix Tables not only guarantees the accuracy of the fire resistance rating, but also provides a source of documentation for the building official.

2.3 EFFECTS OF PENETRATIONS IN FIRE RESISTANT ASSEMBLIES

There are often many features in existing walls or floor/ceiling assemblies which were not included in the original certification or fire testing. The most common examples are pipes and utility wires passed through holes poked through an assembly. During the life of the building, many penetrations are added, and by the time a building is ready for rehabilitation it is not sufficient to just consider the fire resistance of the assembly as originally constructed. It is necessary to consider all penetrations and their relative impact upon fire performance. For instance, the fire resistance of the corridor wall may be less important than the effect of plain glass doors or transoms. In fact, doors are the most important single class of penetrations.

A fully developed fire generates substantial quantities of heat and excess gaseous fuel capable of penetrating any holes which might be present in the walls or ceiling of the fire compartment. In general, this leads to a severe degradation of the fire resistance of those building elements and to a greater potential for fire spread. This is particularly applicable to penetrations located high in a compartment where the positive pressure of the fire can force the unburned gases through the penetration.

Penetrations in a floor/ceiling assembly will generally completely negate the barrier qualities of the assembly and will lead to rapid spread of fire to the space above. It will not be a problem, however, if the penetrations are filled with non-combustible materials strongly fastened to the structure. The upper half of walls are similar to the floor/ceiling assembly in that a positive pressure can reasonably be expected in the top of the room, and this will push hot and/or burning gases through the penetration unless it is completely sealed.

Building codes require doors installed in fire resistive walls to resist the passage of fire for a specified period of time. If the door to a fully involved room is not closed, a large plume of fire will typically escape through the doorway, preventing anyone from using the space outside the door while allowing the fire to spread. This is why door closers are so important. Glass in doors and transoms can be expected to rapidly shatter unless constructed of listed or approved wire glass in a steel frame. As with other building elements, penetrations or nonrated portions of doors and transoms must be upgraded or otherwise protected.

Table 5.1 in Section V of the Appendix contains 41 entries of doors mounted in sound tightfitting frames. Part 3.4 below outlines one procedure for evaluating and possibly upgrading existing doors.

3 FINAL EVALUATION AND DESIGN SOLUTION

The final evaluation begins after the rehabilitation project has reached the final design stage and the choice is made to keep certain archaic materials and assemblies in the rehabilitated building. The final evaluation process is essentially a more refined and detailed version of the preliminary evalua-

tion. The specific fire resistance and flame spread requirements are determined for the project. This may involve local building and fire officials reviewing the preliminary evaluation as depicted in Figures 1 and 2 and the field drawings and notes. When necessary, provisions must be made to upgrade *existing building* elements to provide the required level of fire performance.

There are several approaches to design solutions that can make possible the continued use of archaic materials and assemblies in the rehabilitated structure. The simplest case occurs when the materials and assembly in question are found within the Appendix Tables and the fire performance properties satisfy code requirements. Other approaches must be used, though, if the assembly cannot be found within the Appendix or the fire performance needs to be upgraded. These approaches have been grouped into two classes: experimental and theoretical.

3.1 THE EXPERIMENTAL APPROACH

If a material or assembly found in a building is not listed in the Appendix Tables, there are several other ways to evaluate fire performance. One approach is to conduct the appropriate fire test(s) and thereby determine the fire-related properties directly. There are a number of laboratories in the United States which routinely conduct the various fire tests. A current list can be obtained by writing the Center for Fire Research, National Bureau of Standards, Washington, D.C. 20234.

The contract with any of these testing laboratories should require their observation of specimen preparation as well as the testing of the specimen. A complete description of where and how the specimen was obtained from the building, the transportation of the specimen, and its preparation for testing should be noted in detail so that the building official can be satisfied that the fire test is representative of the actual use.

The test report should describe the fire test procedure and the response of the material or assembly. The laboratory usually submits a cover letter with the report to describe the provisions of the fire test that were satisfied by the material or assembly under investigation. A building official will generally require this cover letter, but will also read the report to confirm that the material or assembly complies with the code requirements. Local code officials should be involved in all phases of the testing process.

The experimental approach can be costly and time consuming because specimens must be taken from the building and transported to the testing laboratory. When a load bearing assembly has continuous reinforcement, the test specimen must be removed from the building, transported, and tested in one piece. However, when the fire performance cannot be determined by other means, there may be no alternative to a full-scale test.

A “nonstandard” small-scale test can be used in special cases. Sample sizes need only be 10-25 square feet (0.93-2.3 m²), while full-scale tests require test samples of either 100 or 180 square feet (9.3 or 17 m²) in size. This small-scale test is best suited for testing nonload-bearing assemblies against thermal transmission only.

3.2 THE THEORETICAL APPROACH

There will be instances when materials and assemblies in a building undergoing rehabilitation cannot be found in the Appendix Tables. Even where test results are available for more or less similar construction, the proper classification may not be immediately apparent. Variations in dimensions, loading conditions, materials, or workmanship may markedly affect the performance of the individual building elements, and the extent of such a possible effect cannot be evaluated from the tables.

Theoretical methods being developed offer an alternative to the full-scale fire tests discussed above. For example, Section 4302(b) of the 1979 edition of the *Uniform Building Code* specifically allows an engineering design for fire resistance in lieu of conducting full-scale tests. These techniques draw upon computer simulation and mathematical modeling, thermodynamics, heat-flow analysis, and materials science to predict the fire performance of building materials and assemblies.

One theoretical method, known as the “Ten Rules of Fire Endurance Ratings,” was published by T. Z. Harmathy in the May, 1965 edition of *Fire Technology*. (35) Harmathy’s Rules provide a foundation for extending the data within the Appendix Tables to analyze or upgrade current as well as archaic building materials or assemblies.

HARMATHY’S TEN RULES

Rule 1: The “thermal”¹ fire endurance of a construction consisting of a number of parallel layers is greater than the sum of the “thermal” fire endurences characteristic of the individual layers when exposed separately to fire.

The minimum performance of an untested assembly can be estimated if the fire endurance of the individual components is known. Though the exact rating of the assembly cannot be stated, the endurance of the assembly is greater than the sum of the endurance of the components.

When a building assembly or component is found to be deficient, the fire endurance can be upgraded by providing a protective membrane. This membrane could be a new layer of brick, plaster, or drywall. The fire endurance of this membrane is called the “finish rating.” Appendix Tables 1.5.1 and 1.5.2 contain the finish ratings for the most commonly employed materials. (See also the notes to Rule 2).

The test criteria for the finish rating is the same as for the thermal fire endurance of the total assembly: average tem-

1. The “thermal” fire endurance is the time at which the average temperature on the unexposed side of a construction exceeds its initial value by 250° when the other side is exposed to the “standard” fire specified by ASTM Test Method E-19.

of manufacture or processing that leads to increased fire endurance. There is no direct relationship between the relative humidity of the air in the pores of the material and the increase in fire endurance.

Under certain conditions there may be explosive spalling of low permeability cementitious materials such as dense concrete. In general, one can assume that extremely old concrete has developed enough minor cracking that this factor should not be significant.

Rule 9: Load-supporting elements, such as beams, girders and joists, yield higher fire endurances when subjected to fire endurance tests as parts of floor, roof, or ceiling assemblies than they would when tested separately.

One of the fire endurance test criteria is the ability of a load-supporting element to carry its design load. The element will be deemed to have failed when the load can no longer be supported.

Failure usually results for two reasons. Some materials, particularly steel and other metals, lose much of their structural strength at elevated temperatures. Physical deflection of the supporting element, due to decreased strength or thermal expansion, causes a redistribution of the load forces and stresses throughout the element. Structural failure often results because the supporting element is not designed to carry the redistributed load.

Roof, floor, and ceiling assemblies have primary (e.g., beams) and secondary (e.g., floor joists) structural members. Since the primary load-supporting elements span the largest distances, their deflection becomes significant at a stage when the strength of the secondary members (including the roof or floor surface) is hardly affected by the heat. As the secondary members follow the deflection of the primary load-supporting element, an increasingly larger portion of the load is transferred to the secondary members.

When load-supporting elements are tested separately, the imposed load is constant and equal to the design load throughout the test. By definition, no distribution of the load is possible because the element is being tested by itself. Without any other structural members to which the load could be transferred, the individual elements cannot yield a higher fire endurance than they do when tested as parts of a floor, roof or ceiling assembly.

Rule 10: The load-supporting elements (beams, girders, joists, etc.) of a floor, roof, or ceiling assembly can be replaced by such other load-supporting elements which, when tested separately, yielded fire endurances not less than that of the assembly.

This rule depends on Rule 9 for its validity. A beam or girder, if capable of yielding a certain performance when tested separately, will yield an equally good or better performance when it forms a part of a floor, roof, or ceiling assembly. It must be emphasized that the supporting element of one assembly must not be replaced by the supporting element of another assembly if the performance of this latter element is not known from a separate (beam) test. Because of the load-

reducing effect of the secondary elements that results from a test performed on an assembly, the performance of the supporting element alone cannot be evaluated by simple arithmetic. This rule also indicates the advantage of performing separate fire tests on primary load-supporting elements.

ILLUSTRATION OF HARMATHY'S RULES

Harmathy provided one schematic figure which illustrated his Rules.¹ It should be useful as a quick reference to assist in applying his Rules.

EXAMPLE APPLICATION OF HARMATHY'S RULES

The following examples, based in whole or in part upon those presented in Harmathy's paper (35), show how the Rules can be applied to practical cases.

Example 1

Problem

A contractor would like to keep a partition which consists of a 3³/₄ inch (95 mm) thick layer of red clay brick, a 1¹/₄ inch (32 mm) thick layer of plywood, and a 3³/₈ inch (9.5 mm) thick layer of gypsum wallboard, at a location where 2-hour fire endurance is required. Is this assembly capable of providing a 2-hour protection?

Solution

- (1) This partition does not appear in the Appendix Tables.
- (2) Bricks of this thickness yield fire endurances of approximately 75 minutes (Table 1.1.2, Item W-4-M-2).
- (3) The 1¹/₄ inch (32 mm) thick plywood has a finish rating of 30 minutes.
- (4) The 3³/₈ inch (9.5 mm) gypsum wallboard has a finish rating of 10 minutes.
- (5) Using the recommended values from the tables and applying Rule 1, the fire endurance (FI) of the assembly is larger than the sum of the individual layers, or

$$FI > 75 + 30 + 10 = 115 \text{ minutes}$$

Discussion

This example illustrates how the Appendix Tables can be utilized to determine the fire resistance of assemblies not explicitly listed.

Example 2

Problem

- (1) A number of buildings to be rehabilitated have the same type of roof slab which is supported with different structural elements.
- (2) The designer and contractor would like to determine whether or not this roof slab is capable of yielding a 2-hour fire endurance. According to a rigorous interpretation of ASTM E119, however, only the roof assembly, including the roof slab as well as the cover and

1. Reproduced from the May 1065 *Fire Technology* (Vol. 1, No. 2). Copyright National Fire Protection Association, Boston. Reproduced by permission.

most economical way of increasing the fire endurance by at least 25 minutes?

Solution

- (1) The most effective technique would be to increase the ceiling plaster thickness. Existing coats of paint would have to be removed and the surface properly prepared before the new plaster could be applied. Other materials (e.g., gypsum wallboard) could also be considered.
- (2) There may be other techniques based on other principles, but an examination of the drawings would be necessary.

Discussion

- (1) The additional plaster has at least three effects:
 - a) The layer of plaster is increased and thus there is a gain of fire endurance (Rule 1).
 - b) There is a gain due to shifting the air gap farther from the exposed surface (Rule 4).
 - c) There is more moisture in the path of heat flow to the structural elements (Rules 7 and 8).
- (2) The increase in fire endurance would be at least as large as that of the finish rating for the added thickness of plaster. The combined effects in (1) above would further increase this by a factor of 2 or more, depending upon the geometry of the assembly.

Example 4

Problem

The fire endurance of item W-10-M-1 in Table 1.1.5 is 4 hours. This wall consists of two $3\frac{3}{4}$ inch (95 mm) thick layers of structural tiles separated by a 2-inch (51 mm) air gap and $\frac{3}{4}$ inch (19 mm) portland cement plaster or stucco on both sides. If the actual wall in the building is identical to item W-10-M-1 except that it has a 4-inch (102 mm) air gap, can the fire endurance be estimated at 5 hours?

Solution

The answer to the question is no for the reasons contained in Rule 5.

Example 5

Problem

In order to increase the insulating value of its precast roof slabs, a company has decided to use two layers of different concretes. The lower layer of the slabs, where the strength of the concrete is immaterial (all the tensile load is carried by the steel reinforcement), would be made with a concrete of low strength but good insulating value. The upper layer, where the concrete is supposed to carry the compressive load, would remain the original high strength, high thermal conductivity concrete. How will the fire endurance of the slabs be affected by the change?

Solution

The effect on the thermal fire endurance is beneficial:

- (1) The total resistance to heat flow of the new slabs has been increased due to the replacement of a layer of high thermal conductivity by one of low conductivity.
- (2) The layer of low conductivity is on the side more likely to be exposed to fire, where it is more effectively utilized according to Rule 6. The layer of low thermal conductivity also provides better protection for the steel reinforcement, thereby extending the time before reaching the temperature at which the creep of steel becomes significant.

3.3

“THICKNESS DESIGN” STRATEGY

The “thickness design” strategy is based upon Harmathy’s Rules 1 and 2. This design approach can be used when the construction materials have been identified and measured, but the specific assembly cannot be located within the tables. The tables should be surveyed again for thinner walls of like material and construction detail that have yielded the desired or greater fire endurance. If such an assembly can be found, then the thicker walls in the building have more than enough fire resistance. The thickness of the walls thus becomes the principal concern.

This approach can also be used for floor/ceiling assemblies, except that the thickness of the cover¹ and the slab become the central concern. The fire resistance of the untested assembly will be at least the fire resistance of an assembly listed in the table having a similar design but with less cover and/or thinner slabs. For other structural elements (e.g., beams and columns), the element listed in the table must also be of a similar design but with less cover thickness.

3.4

EVALUATION OF DOORS

A separate section on doors has been included because the process for evaluation presented below differs from those suggested previously for other building elements. The impact of unprotected openings or penetrations in fire resistant assemblies has been detailed in Part 2.3 above. It is sufficient to note here that openings left unprotected will likely lead to failure of the barrier under actual fire conditions.

For other types of building elements (e.g., beams, columns), the Appendix Tables can be used to establish a minimum level of fire performance. The benefit to rehabilitation is that the need for a full-scale fire test is then eliminated. For doors, however, this cannot be done. The data contained in Appendix Table 5.1, Resistance of Doors to Fire Exposure, can only provide guidance as to whether a successful fire test is even feasible.

1. Cover: the protective layer or membrane of material which slows the flow of heat to the structural elements.

RESOURCE A

For example, a door required to have 1 hour fire resistance is noted in the tables as providing only 5 minutes. The likelihood of achieving the required 1 hour, even if the door is upgraded, is remote. The ultimate need for replacement of the doors is reasonably clear, and the expense and time needed for testing can be saved. However, if the performance documented in the table is near or in excess of what is being required, then a fire test should be conducted. The test documentation can then be used as evidence of compliance with the required level of performance.

The table entries cannot be used as the sole proof of performance of the door in question because there are too many unknown variables which could measurably affect fire performance. The wood may have dried over the years; coats of flammable varnish could have been added. Minor deviations in the internal construction of a door can result in significant differences in performance. Methods of securing inserts in panel doors can vary. The major non-destructive method of analysis, an x-ray, often cannot provide the necessary detail. It is for these, and similar reasons, that a fire test is still felt to be necessary.

It is often possible to upgrade the fire performance of an existing door. Sometimes, “as is” and modified doors are evaluated in a single series of tests when failure of the unmodified door is expected. Because doors upgraded after

an initial failure must be tested again, there is a potential savings of time and money.

The most common problems encountered are plain glass, panel inserts of insufficient thickness, and improper fit of a door in its frame. The latter problem can be significant because a fire can develop a substantial positive pressure, and the fire will work its way through otherwise innocent-looking gaps between door and frame.

One approach to solving these problems is as follows. The plain glass is replaced with approved or listed wire glass in a steel frame. The panel inserts can be upgraded by adding an additional layer of material. Gypsum wallboard is often used for this purpose. Intumescent paint applied to the edges of the door and frame will expand when exposed to fire, forming an effective seal around the edges. This seal, coupled with the generally even thermal expansion of a wood door in a wood frame, can prevent the passage of flames and other fire gases. Figure 3 below illustrates these solutions.

Because the interior construction of a door cannot be determined by a visual inspection, there is no absolute guarantee that the remaining doors are identical to the one(s) removed from the building and tested. But the same is true for doors constructed today, and reason and judgment must be applied. Doors that appear identical upon visual inspection can be weighed. If the weights are reasonably close, the doors

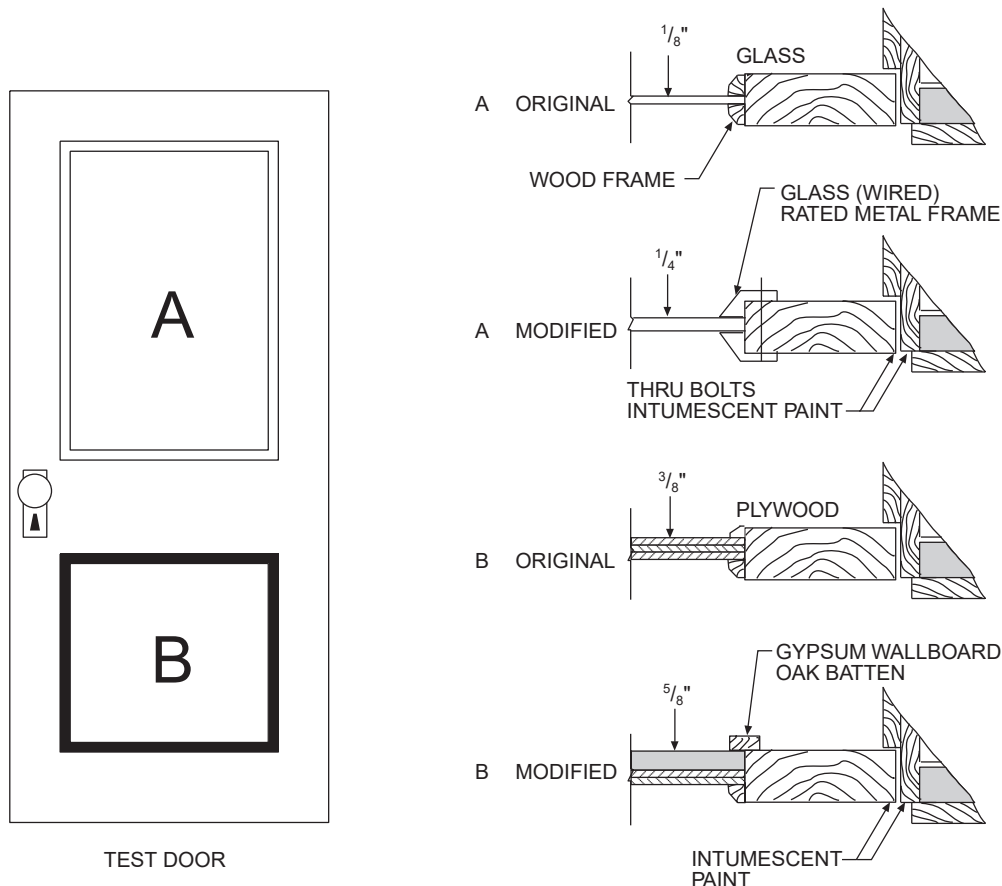

**FIGURE 3
MODIFICATION DETAILS**

can be assumed to be identical and therefore provide the same level of fire performance. Another approach is to fire test more than one door or to dismantle doors selected at random to see if they had been constructed in the same manner. Original building plans showing door details or other records showing that doors were purchased at one time or obtained from a single supplier can also be evidence of similar construction.

More often though, it is what is visible to the eye that is most significant. The investigator should carefully check the condition and fit of the door and frame, and for frames out of plumb or separating from the wall. Door closers, latches, and hinges must be examined to see that they function properly and are tightly secured. If these are in order and the door and frame have passed a full-scale test, there can be a reasonable basis for allowing the existing doors to remain.

4 SUMMARY

This section summarizes the various approaches and design solutions discussed in the preceding sections of the guideline. The term “structural system” includes: frames, beams, columns, and other structural elements. “Cover” is a protective layer(s) of materials or membrane which slows the flow of heat to the structural elements. It cannot be stressed too strongly that the fire endurance of actual building elements can be greatly reduced or totally negated by removing part of the cover to allow pipes, ducts, or conduits to pass through the element. This must be repaired in the rehabilitation process.

The following approaches shall be considered equivalent.

4.1 The fire resistance of a building element can be established from the Appendix Tables. This is subject to the following limitations:

The building element in the rehabilitated building shall be constructed of the same materials with the same nominal dimensions as stated in the tables.

All penetrations in the building element or its cover for services such as electricity, plumbing, and HVAC shall be packed with noncombustible cementitious materials and so fixed that the packing material will not fall out when it loses its water of hydration.

The effects of age and wear and tear shall be repaired so that the building element is sound and the original thickness of all components, particularly covers and floor slabs, is maintained.

This approach essentially follows the approach taken by model building codes. The assembly must appear in a table either published in or accepted by the code for a given fire resistance rating to be recognized and accepted.

4.2 The fire resistance of a building element which does not explicitly appear in the Appendix Tables can be established if one or more elements of same design but different dimensions have been listed in the tables. For walls, the existing

element must be thicker than the one listed. For floor/ceiling assemblies, the assembly listed in the table must have the same or less cover and the same or thinner slab constructed of the same material as the actual floor/ceiling assembly. For other structural elements, the element listed in the table must be of a similar design but with less cover thickness. The fire resistance in all instances shall be the fire resistance recommended in the table. This is subject to the following limitations:

The actual element in the rehabilitated building shall be constructed of the same materials as listed in the table. Only the following dimensions may vary from those specified: for walls, the overall thickness must exceed that specified in the table; for floor/ceiling assemblies, the thickness of the cover and the slab must be greater than, or equal to, that specified in the table; for other structural elements, the thickness of the cover must be greater than that specified in the table.

All penetrations in the building element or its cover for services such as electricity, plumbing, or HVAC shall be packed with noncombustible cementitious materials and so fixed that the packing material will not fall out when it loses its water of hydration.

The effects of age and wear and tear shall be repaired so that the building element is sound and the original thickness of all components, particularly covers and floor slabs, is maintained.

This approach is an application of the “thickness design” concept presented in Part 3.3 of the guideline. There should be many instances when a thicker building element was utilized than the one listed in the Appendix Tables. This guideline recognizes the inherent superiority of a thicker design. Note: “thickness design” for floor/ceiling assemblies and structural elements refers to cover and slab thickness rather than total thickness.

The “thickness design” concept is essentially a special case of Harmathy’s Rules (specifically Rules 1 and 2). It should be recognized that the only source of data is the Appendix Tables. If other data are used, it must be in connection with the approach below.

4.3 The fire resistance of building elements can be established by applying Harmathy’s Ten Rules of Fire Resistance Ratings as set forth in Part 3.2 of the guideline. This is subject to the following limitations:

The data from the tables can be utilized subject to the limitations in 4.2 above.

Test reports from recognized journals or published papers can be used to support data utilized in applying Harmathy’s Rules.

Calculations utilizing recognized and well established computational techniques can be used in applying Harmathy’s Rules. These include, but are not limited to, analysis of heat flow, mechanical properties, deflections, and load bearing capacity.

APPENDIX

INTRODUCTION

The fire-resistance tables that follow are a part of Resource A and provide a tabular form of assigning fire-resistance ratings to various archaic building elements and assemblies.

These tables for archaic materials and assemblies do for archaic materials what Tables 721.1(1-3) of the *International Building Code*[®] do for more modern building elements and assemblies. The fire-resistance tables of Resource A should be used as described in the “Purpose and Procedure” that follows the table of contents for these tables.

RESOURCE A TABLE OF CONTENTS

Purpose and Procedure		169	
Section I—Walls			
1.1.1	Masonry	0 in. - 4 in. thick	170
1.1.2	Masonry	4 in. - 6 in. thick	173
1.1.3	Masonry	6 in. - 8 in. thick	180
1.1.4	Masonry	8 in. - 10 in. thick	185
1.1.5	Masonry	10 in. - 12 in. thick	193
1.1.6	Masonry	12 in. - 14 in. thick	197
1.1.7	Masonry	14 in. or more thick	203
1.2.1	Metal Frame	0 in. - 4 in. thick	206
1.2.2	Metal Frame	4 in. - 6 in. thick	210
1.2.3	Metal Frame	6 in. - 8 in. thick	212
1.2.4	Metal Frame	8 in. - 10 in. thick	213
1.3.1	Wood Frame	0 in. - 4 in. thick	214
1.3.2	Wood Frame	4 in. - 6 in. thick	215
1.3.3	Wood Frame	6 in. - 8 in. thick	223
1.4.1	Miscellaneous Materials	0 in. - 4 in. thick	223
1.4.2	Miscellaneous Materials	4 in. - 6 in. thick	224
1.5.1	Finish Ratings—Inorganic Materials	Thickness	225
1.5.2	Finish Ratings—Organic Materials	Thickness	226
Section II—Columns			
2.1.1	Reinforced Concrete	Min. Dim. 0 in. - 6 in.	227
2.1.2	Reinforced Concrete	Min. Dim. 10 in. - 12 in.	228
2.1.3	Reinforced Concrete	Min. Dim. 12 in. - 14 in.	231
2.1.4	Reinforced Concrete	Min. Dim. 14 in. - 16 in.	232
2.1.5	Reinforced Concrete	Min. Dim. 16 in. - 18 in.	233
2.1.6	Reinforced Concrete	Min. Dim. 18 in. - 20 in.	235
2.1.7	Reinforced Concrete	Min. Dim. 20 in. - 22 in.	236
2.1.8	Hexagonal Reinforced Concrete	Diameter—12 in. - 14 in.	237

PURPOSE AND PROCEDURE

The tables and histograms which follow are to be used only within the analytical framework detailed in the main body of this guideline.

Histograms precede any table with 10 or more entries. The use and interpretation of these histograms is explained in Part 2 of the guideline. The tables are in a format similar to that found in the model building codes. The following example, taken from an entry in Table 1.1.2, best explains the table format.

1. Item Code: The item code consists of a four place series in the general form w-x-y-z in which each member of the series denotes the following:

- w = Type of building element (e.g., W=Walls; F=Floors, etc.)
- x = The building element thickness rounded down to the nearest 1-inch increment (e.g., 4⁵/₈ inches is rounded off to 4 inches)
- y = The general type of material from which the building element is constructed (e.g., M=Masonry; W=Wood, etc.)
- z = The item number of the particular building element in a given table

The item code shown in the example W-4-M-50 denotes the following:

- W = Wall, as the building element
- 4 = Wall thickness in the range of 4 inches (102 mm) to less than 5 inches (127 mm)
- M = Masonry construction
- 50 = The 50th entry in Table 1.1.2

2. The specific name or heading of this column identifies the dimensions which, if varied, has the greatest impact on fire resistance. The critical dimension for walls, the example here, is thickness. It is different for other building elements (e.g., depth for beams; membrane thickness for some floor/ceiling assemblies). The table entry is the named dimension of the building element measured at the time of actual testing to within ±¹/₈ inch

(3.2 mm) tolerance. The thickness tabulated includes facings where facings are a part of the wall construction.

3. Construction Details: The construction details provide a brief description of the manner in which the building element was constructed.
4. Performance: This heading is subdivided into two columns. The column labeled “Load” will either list the load that the building element was subjected to during the fire test or it will contain a note number which will list the load and any other significant details. If the building element was not subjected to a load during the test, this column will contain “n/a,” which means “not applicable.”

The second column under performance is labeled “Time” and denotes the actual fire endurance time observed in the fire test.

5. Reference Number: This heading is subdivided into three columns: Pre-BMS-92; BMS-92; and Post-BMS-92. The table entry under this column is the number in the Bibliography of the original source reference for the test data.
6. Notes: Notes are provided at the end of each table to allow a more detailed explanation of certain aspects of the test. In certain tables the notes given to this column have also been listed under the “Construction Details” and/or “Load” columns.
7. Rec Hours: This column lists the recommended fire endurance rating, in hours, of a building element. In some cases, the recommended fire endurance will be less than that listed under the “Time” column. In no case is the “Rec Hours” greater than given in the “Time” column.

ITEM CODE	THICKNESS	CONSTRUCTION DETAILS	PERFORMANCE		REFERENCE NUMBER			NOTES	REC. HOURS
			LOAD	TIME	PRE-BMS-92	BMS-92	POST-BMS-92		
W-4-M-50	4 ⁵ / ₈ "	Core: structural clay tile, See notes 12, 16, 21; Facings on unexposed side only, see note 18	N/A	25 min.		1		3, 4, 24	1/3

SECTION I - WALLS

FIGURE 1.1.1
MASONRY WALLS
0" TO LESS THAN 4" THICK

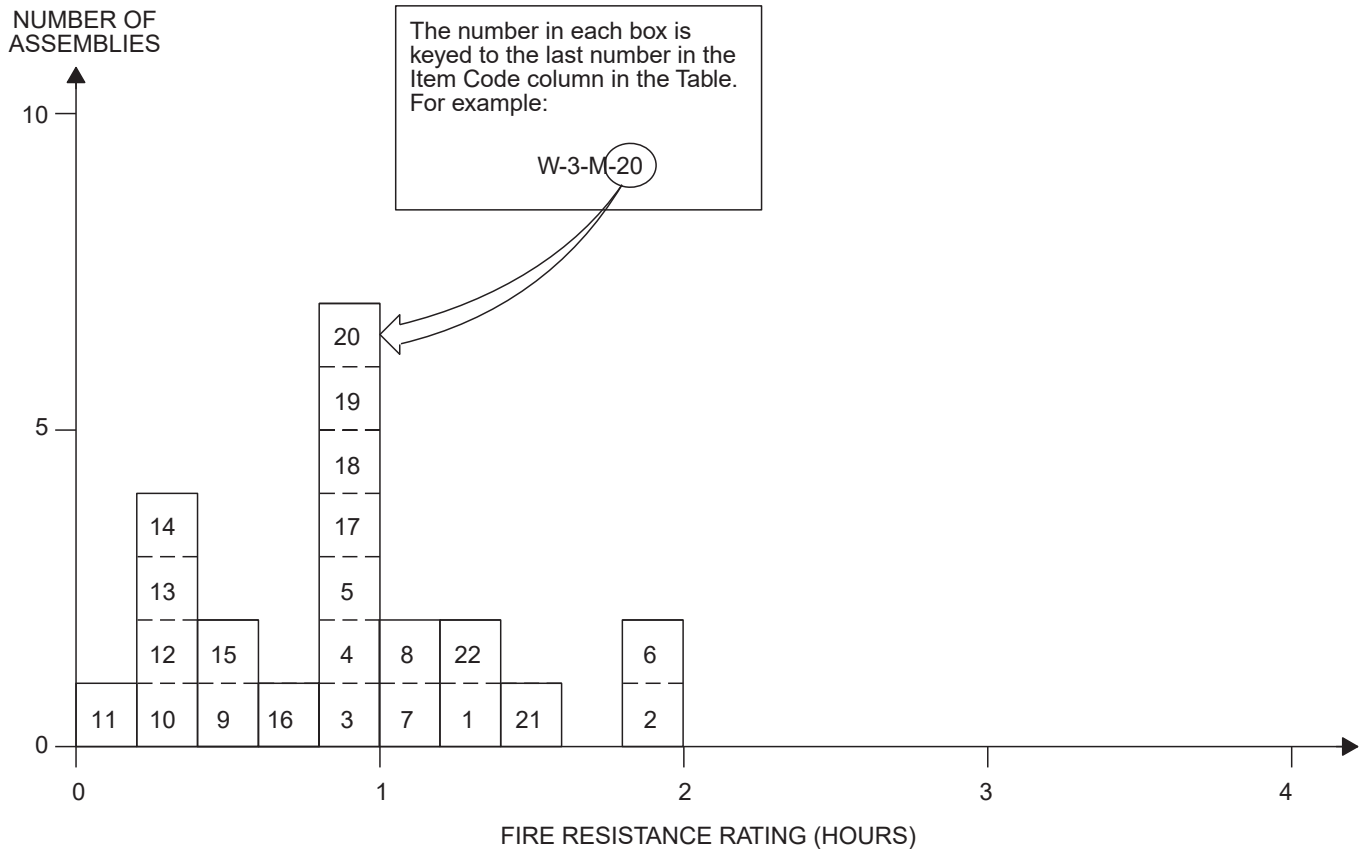

TABLE 1.1.1
MASONRY WALLS
0" TO LESS THAN 4" THICK

ITEM CODE	THICKNESS	CONSTRUCTION DETAILS	PERFORMANCE		REFERENCE NUMBER			NOTES	REC. HOURS
			LOAD	TIME	PRE-BMS-92	BMS-92	POST-BMS-92		
W-2-M-1	2 1/4"	Solid partition; 3/4" gypsum plank- 10' x 1'6" ; 3/4" plus gypsum plaster each side.	N/A	1 hr. 22 min.			7	1	1 1/4
W-3-M-2	3"	Concrete block (18" x 9" x 3") of fuel ash, portland cement and plasticizer; cement/sand mortar.	N/A	2 hrs.			7	2, 3	2
W-2-M-3	2"	Solid gypsum block wall; No facings	N/A	1 hr.		1		4	1
W-3-M-4	3"	Solid gypsum blocks, laid in 1:3 sanded gypsum mortar.	N/A	1 hr.		1		4	1
W-3-M-5	3"	Magnesium oxysulfate wood fiber blocks; 2" thick, laid in portland cement-lime mortar; Facings: 1/2" of 1:3 sanded gypsum plaster on both sides.	N/A	1 hr.		1		4	1
W-3-M-6	3"	Magnesium oxysulfate bound wood fiber blocks; 3" thick; laid in portland cement-lime mortar; Facings: 1/2" of 1:3 sanded gypsum plaster on both sides.	N/A	2 hrs.		1		4	2

(continued)

**TABLE 1.1.1—continued
MASONRY WALLS
0" TO LESS THAN 4" THICK**

ITEM CODE	THICKNESS	CONSTRUCTION DETAILS	PERFORMANCE		REFERENCE NUMBER			NOTES	REC. HOURS
			LOAD	TIME	PRE-BMS-92	BMS-92	POST-BMS-92		
W-3-M-7	3"	Clay tile; Ohio fire clay; single cell thick; Face plaster: 5/8" (both sides) 1:3 sanded gypsum; Design "E," Construction "A."	N/A	1 hr. 6 min.	0		2	5, 6, 7, 11, 12, 39	1
W-3-M-8	3"	Clay tile; Illinois surface clay; single cell thick; Face plaster: 5/8" (both sides) 1:3 sanded gypsum; Design "A," Construction "E."	N/A	1 hr. 1 min			2	5, 8, 9, 11, 12, 39	1
W-3-M-9	3"	Clay tile; Illinois surface clay; single cell thick; No face plaster; Design "A," Construction "C."	N/A	25 min.			2	5, 10, 11, 12, 39	1/3
W-3-M-10	3 7/8"	8" x 4 7/8" glass blocks; weight 4 lbs. each; portland cement-lime mortar; horizontal mortar joints reinforced with metal lath.	N/A	15 min.		1		4	1/4
W-3-M-11	3"	Core: structural clay tile; see Notes 14, 18, 13; No facings.	N/A	10 min.		1		5, 11, 26	1/6
W-3-M-12	3"	Core: structural clay tile; see Notes 14, 19, 23; No facings.	N/A	20 min.		1		5, 11, 26	1/3
W-3-M-13	3 5/8"	Core: structural clay tile; see Notes 14, 18, 23; Facings: unexposed side; see Note 20.	N/A	20 min.		1		5, 11, 26	1/3
W-3-M-14	3 5/8"	Core: structural clay tile; see Notes 14, 19, 23; Facings: unexposed side only; see Note 20.	N/A	20 min.		1		5, 11, 26	1/3
W-3-M-15	3 5/8"	Core: clay structural tile; see Notes 14, 18, 23; Facings: side exposed to fire; see Note 20.	N/A	30 min.		1		5, 11, 26	1/2
W-3-M-16	3 5/8"	Core: clay structural tile; see Notes 14, 19, 23; Facings: side exposed to fire; see Note 20.	N/A	45 min.		1		5, 11, 26	3/4
W-2-M-17	2"	2" thick solid gypsum blocks; see Note 27.	N/A	1 hr.		1		27	1
W-3-M-18	3"	Core: 3" thick gypsum blocks 70% solid; see Note 2; No facings.	N/A	1 hr.		1		27	1
W-3-M-19	3"	Core: hollow concrete units; see Notes 29, 35, 36, 38; No facings.	N/A	1 hr.		1		27	1
W-3-M-20	3"	Core: hollow concrete units; see Notes 28, 35, 36, 37, 38; No facings.	N/A	1 hr.		1			1
W-3-M-21	3 1/2"	Core: hollow concrete units; see Notes 28, 35, 36, 37, 38; Facings: one side; see Note 37.	N/A	1 1/2 hrs.		1			1 1/2
W-3-M-22	3 1/2"	Core: hollow concrete units; see Notes 29, 35, 36, 38; Facings: one side, see Note 37.	N/A	1 1/4 hrs.		1			1 1/4

For SI: 1 inch = 25.4 mm, 1 pound per square inch = 0.00689 MPa, °C = [(°F) - 32]/1.8.

Notes:

1. Failure mode—flame thru.
2. Passed 2-hour fire test (Grade "C" fire res. - British).
3. Passed hose stream test.
4. Tested at NBS under ASA Spec. No. A2-1934. As nonload bearing partitions.
5. Tested at NBS under ASA Spec. No. 42-1934 (ASTM C19-33) except that hose stream testing where carried was run on test specimens exposed for full test duration, not for a reduced period as is contemporarily done.
6. Failure by thermal criteria—maximum temperature rise 325°F.
7. Hose stream failure.
8. Hose stream—pass.
9. Specimen removed prior to any failure occurring.
10. Failure mode—collapse.
11. For clay tile walls, unless the source or density of the clay can be positively identified or determined, it is suggested that the lowest hourly rating for the fire endurance of a clay tile partition of that thickness be followed. Identified sources of clay showing longer fire endurance can lead to longer time recommendations.

(continued)

RESOURCE A

**TABLE 1.1.1—continued
MASONRY WALLS
0" TO LESS THAN 4" THICK**

12. See appendix for construction and design details for clay tile walls.
13. Load: 80 psi for gross wall area.
14. One cell in wall thickness.
15. Two cells in wall thickness.
16. Double shells plus one cell in wall thickness.
17. One cell in wall thickness, cells filled with broken tile, crushed stone, slag cinders or sand mixed with mortar.
18. Dense hard-burned clay or shale tile.
19. Medium-burned clay tile.
20. Not less than $\frac{5}{8}$ inch thickness of 1:3 sanded gypsum plaster.
21. Units of not less than 30 percent solid material.
22. Units of not less than 40 percent solid material.
23. Units of not less than 50 percent solid material.
24. Units of not less than 45 percent solid material.
25. Units of not less than 60 percent solid material.
26. All tiles laid in portland cement-lime mortar.
27. Blocks laid in 1:3 sanded gypsum mortar voids in blocks not to exceed 30 percent.
28. Units of expanded slag or pumice aggregate.
29. Units of crushed limestone, blast furnace, slag, cinders and expanded clay or shale.
30. Units of calcareous sand and gravel. Coarse aggregate, 60 percent or more calcite and dolomite.
31. Units of siliceous sand and gravel. Ninety percent or more quartz, chert or flint.
32. Unit at least 49 percent solid.
33. Unit at least 62 percent solid.
34. Unit at least 65 percent solid.
35. Unit at least 73 percent solid.
36. Ratings based on one unit and one cell in wall thickness.
37. Minimum of $\frac{1}{2}$ inch—1:3 sanded gypsum plaster.
38. Nonload bearing.
39. See Clay Tile Partition Design Construction drawings, below.

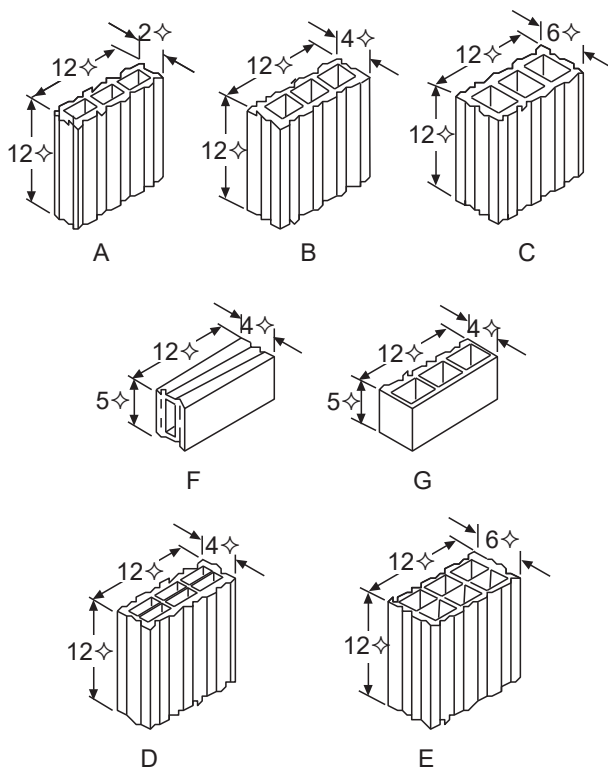

DESIGNS OF TILES USED IN FIRE-TEST PARTITIONS

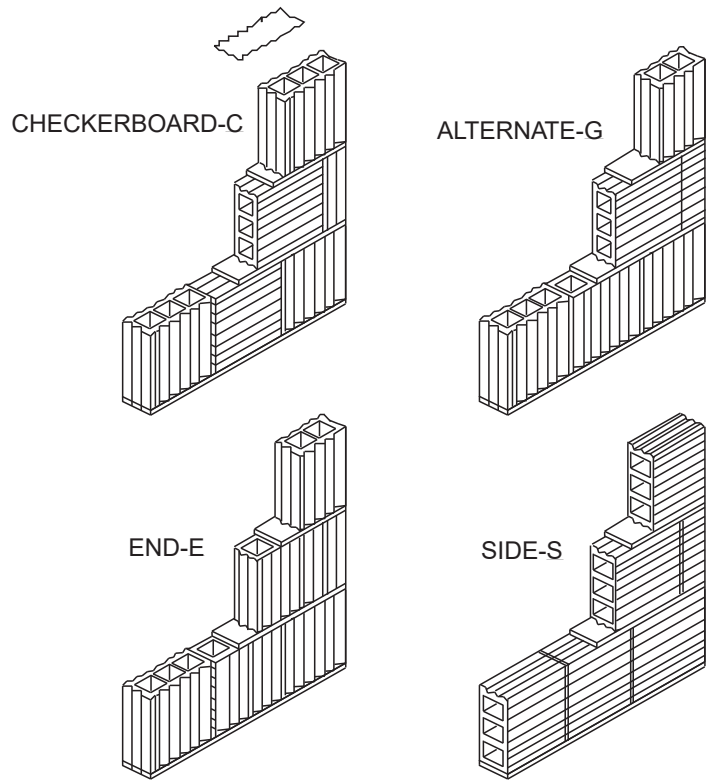

THE FOUR TYPES OF CONSTRUCTION USED IN FIRE-TEST PARTITIONS

**FIGURE 1.1.2
MASONRY WALLS
4" TO LESS THAN 6" THICK**

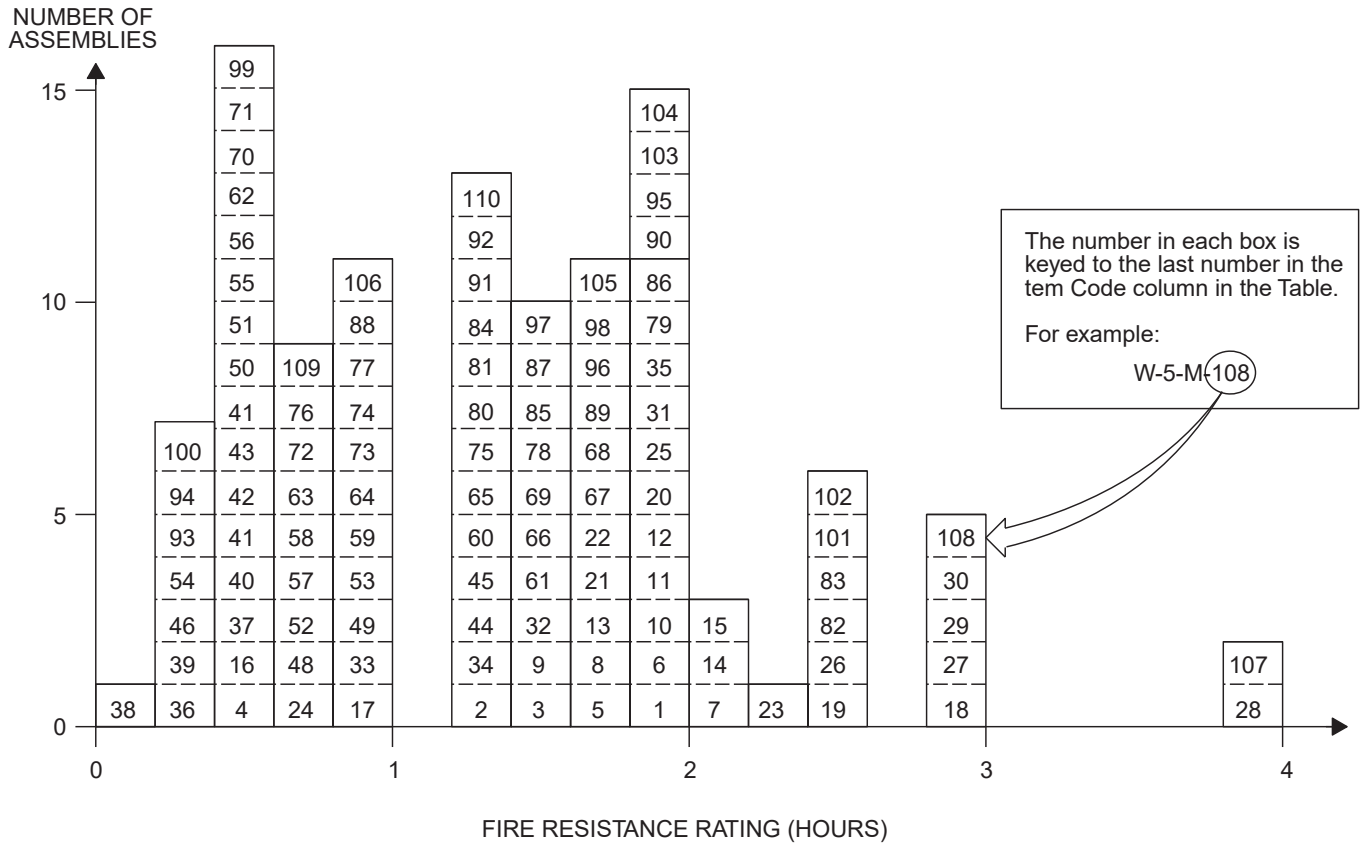

**TABLE 1.1.2
MASONRY WALLS
4" TO LESS THAN 6" THICK**

ITEM CODE	THICKNESS	CONSTRUCTION DETAILS	PERFORMANCE		REFERENCE NUMBER			NOTES	REC. HOURS
			LOAD	TIME	PRE-BMS-92	BMS-92	POST-BMS-92		
W-4-M-1	4"	Solid 3" thick, gypsum blocks laid in 1:3 sanded gypsum mortar; Facings: 1/2" of 1:3 sanded gypsum plaster (both sides).	N/A	2 hrs.		1		1	2
W-4-M-2	4"	Solid clay or shale brick.	N/A	1 hr. 15 min.		1		1, 2	1 1/4
W-4-M-3	4"	Concrete; No facings.	N/A	1 hr. 30 min.		1		1	1 1/2
W-4-M-4	4"	Clay tile; Illinois surface clay; single cell thick; No face plaster; Design "B," Construction "C."	N/A	25 min.			2	3-7, 36	1/3
W-4-M-5	4"	Solid sand-lime brick.	N/A	1 hr. 45 min.		1		1	1 3/4
W-4-M-6	4"	Solid wall; 3" thick block; 1/2" plaster each side; 17 3/4" x 8 3/4" x 4" "Breeze Blocks"; portland cement/sand mortar.	N/A	1 hr. 52 min.			7	2	1 3/4
W-4-M-7	4"	Concrete (4020 psi); Reinforcement: vertical 3/8"; horizontal 1/4"; 6" x 6" grid.	N/A	2 hrs. 10 min.			7	2	2
W-4-M-8	4"	Concrete wall (4340 psi crush); reinforcement 1/4" diameter rebar on 8" centers (vertical and horizontal).	N/A	1 hr. 40 min.			7	2	1 2/3

(continued)

**TABLE 1.1.2—continued
MASONRY WALLS
4" TO LESS THAN 6" THICK**

ITEM CODE	THICKNESS	CONSTRUCTION DETAILS	PERFORMANCE		REFERENCE NUMBER			NOTES	REC. HOURS
			LOAD	TIME	PRE-BMS-92	BMS-92	POST-BMS-92		
W-4-M-9	4 ³ / ₁₆ "	4 ³ / ₁₆ " × 2 ⁵ / ₈ " cellular fletton brick (1873 psi) with 1/2" sand mortar; bricks are U-shaped yielding hollow cover (approx. 2" × 4") in final cross-section configuration.	N/A	1 hr. 25 min.			7	2	1 ¹ / ₃
W-4-M-10	4 ¹ / ₄ "	4 ¹ / ₄ " × 2 ¹ / ₂ " fletton (1831 psi) brick in 1/2" sand mortar.	N/A	1 hr. 53 min			7	2	3 ³ / ₄
W-4-M-11	4 ¹ / ₄ "	4 ¹ / ₄ " × 2 ¹ / ₂ " London stock (683 psi) brick; 1/2" grout.	N/A	1 hr. 52 min.			7	2	3 ³ / ₄
W-4-M-12	4 ¹ / ₂ "	4 ¹ / ₄ " × 2 ¹ / ₂ " Leicester red, wire-cut brick (4465 psi) in 1/2" sand mortar.	N/A	1 hr. 56 min.			7	6	3 ³ / ₄
W-4-M-13	4 ¹ / ₄ "	4 ¹ / ₄ " × 2 ¹ / ₂ " stairfoot brick (7527 psi) 1/2" sand mortar.	N/A	1 hr. 37 min.			7	2	1 ¹ / ₂
W-4-M-14	4 ¹ / ₄ "	4 ¹ / ₄ " × 2 ¹ / ₂ " sand-lime brick (2603 psi) 1/2" sand mortar.	N/A	2 hrs. 6 min.			7	2	2
W-4-M-15	4 ¹ / ₄ "	4 ¹ / ₄ " × 2 ¹ / ₂ " concrete brick (2527 psi) 1/2" sand mortar.	N/A	2 hrs. 10 min.			7	2	2
W-4-M-16	4 ¹ / ₂ "	4" thick clay tile; Ohio fire clay; single cell thick; No plaster exposed face; 1/2" 1:2 gypsum back face; Design "F," Construction "S."	N/A	31 min.			2	3-6, 36	1/2
W-4-M-17	4 ¹ / ₂ "	4" thick clay tile; Ohio fire clay; single cell thick; Plaster exposed face; 1/2" 1:2 sanded gypsum; Back Face: none; Construction "S," Design "F."	80 psi	50 min.			2	3-5, 8, 36	3/4
W-4-M-18	4 ¹ / ₂ "	Core: solid sand-lime brick; 1/2" sanded gypsum plaster facings on both sides.	80 psi	3 hrs.		1		1, 11	3
W-4-M-19	4 ¹ / ₂ "	Core: solid sand-lime brick; 1/2" sanded gypsum plaster facings on both sides.	80 psi	2 hrs. 30 min.		1		1, 11	2 ¹ / ₂
W-4-M-20	4 ¹ / ₂ "	Core: concrete brick 1/2" of 1:3 sanded gypsum plaster facings on both sides.	80 psi	2 hrs.		1		1, 11	2
W-4-M-21	4 ¹ / ₂ "	Core: solid clay or shale brick; 1/2" thick, 1:3 sanded gypsum plaster facings on fire sides.	80 psi	1 hr. 45 min.		1		1, 2, 11	3 ³ / ₄
W-4-M-22	4 ³ / ₄ "	4" thick clay tile; Ohio fire clay; single cell thick; cells filled with cement and broken tile concrete; Plaster on exposed face; none on unexposed face; 3/4" 1:3 sanded gypsum; Design "G," Construction "E."	N/A	1 hr. 48 min.			2	2, 3-5, 9, 36	3 ³ / ₄
W-4-M-23	4 ³ / ₄ "	4" thick clay tile; Ohio fire clay; single cell thick; cells filled with cement and broken tile concrete; No plaster exposed faced; 3/4" neat gypsum plaster on unexposed face; Design "G," Construction "E."	N/A	2 hrs. 14 min.			2	2, 3-5, 9, 36	2
W-5-M-24	5"	3" × 13" air space; 1" thick metal reinforced concrete facings on both sides; faces connected with wood splines.	2,250 lbs./ft.	45 min.		1		1	3/4
W-5-M-25	5"	Core: 3" thick void filled with "nondulated" mineral wool weighing 10 lbs./ft. ³ ; 1" thick metal reinforced concrete facings on both sides.	2,250 lbs./ft.	2 hrs.		1		1	2
W-5-M-26	5"	Core: solid clay or shale brick; 1/2" thick, 1:3 sanded gypsum plaster facings on both sides.	40 psi	2 hrs. 30 min.		1		1, 2, 11	2 ¹ / ₂
W-5-M-27	5"	Core: solid 4" thick gypsum blocks, laid in 1:3 sanded gypsum mortar; 1/2" of 1:3 sanded gypsum plaster facings on both sides.	N/A	3 hrs.		1		1	3

(continued)

**TABLE 1.1.2—continued
MASONRY WALLS
4" TO LESS THAN 6" THICK**

ITEM CODE	THICKNESS	CONSTRUCTION DETAILS	PERFORMANCE		REFERENCE NUMBER			NOTES	REC. HOURS
			LOAD	TIME	PRE-BMS-92	BMS-92	POST-BMS-92		
W-5-M-28	5"	Core: 4" thick hollow gypsum blocks with 30% voids; blocks laid in 1:3 sanded gypsum mortar; No facings.	N/A	4 hrs.		1		1	4
W-5-M-29	5"	Core: concrete brick; 1/2" of 1:3 sanded gypsum plaster facings on both sides.	160 psi	3 hrs.		1		1	3
W-5-M-30	5 1/4"	4" thick clay tile; Illinois surface clay; double cell thick; Plaster: 5/8" sanded gypsum 1:3 both faces; Design "D," Construction "S."	N/A	2 hrs. 53 min.			2	2-5, 9, 36	2 3/4
W-5-M-31	5 1/4"	4" thick clay tile; New Jersey fire clay; double cell thick; Plaster: 5/8" sanded gypsum 1:3 both faces; Design "D," Construction "S."	N/A	1 hr. 52 min.			2	2-5, 9, 36	1 3/4
W-5-M-32	5 1/4"	4" thick clay tile; New Jersey fire clay; single cell thick; Plaster: 5/8" sanded gypsum 1:3 both faces; Design "D," Construction "S."	N/A	1 hr. 34 min.	2		2	2-5, 9, 36	1 1/2
W-5-M-33	5 1/4"	4" thick clay tile; New Jersey fire clay; single cell thick; Face plaster: 5/8" both sides; 1:3 sanded gypsum; Design "B," Construction "S."	N/A	50 min.			2	3-5, 8, 36	3/4
W-5-M-34	5 1/4"	4" thick clay tile; Ohio fire clay; single cell thick; Face plaster: 5/8" both sides; 1:3 sanded gypsum; Design "B," Construction "A."	N/A	1 hr. 19 min.			2	2-5, 9, 36	1 1/4
W-5-M-35	5 1/4"	4" thick clay tile; Illinois surface clay; single cell thick; Face plaster: 5/8" both sides; 1:3 sanded gypsum; Design "B," Construction "S."	N/A	1 hr. 59 min.			2	2-5, 10 36	1 3/4
W-5-M-36	4"	Core: structural clay tile; see Notes 12, 16, 21; No facings.	N/A	15 min.		1		3, 4, 24	1/4
W-4-M-37	4"	Core: structural clay tile; see Notes 12, 17, 21; No facings.	N/A	25 min.		1		3, 4, 24	1/3
W-4-M-38	4"	Core: structural clay tile; see Notes 12, 16, 20; No facings.	N/A	10 min.		1		3, 4, 24	1/6
W-4-M-39	4"	Core: structural clay tile; see Notes 12, 17, 20; No facings.	N/A	20 min.		1		3, 4, 24	1/3
W-4-M-40	4"	Core: structural clay tile; see Notes 13, 16, 23; No facings.	N/A	30 min.		1		3, 4, 24	1/2
W-4-M-41	4"	Core: structural clay tile; see Notes 13, 17, 23; No facings.	N/A	35 min.		1		3, 4, 24	1/2
W-4-M-42	4"	Core: structural clay tile; see Notes 13, 16, 21; No facings.	N/A	25 min.		1		3, 4, 24	1/3
W-4-M-43	4"	Core: structural clay tile; see Notes 13, 17, 21; No facings.	N/A	30 min.		1		3, 4, 24	1/2
W-4-M-44	4"	Core: structural clay tile; see Notes 15, 16, 20; No facings	N/A	1 hr. 15 min.		1		3, 4, 24	1 1/4
W-4-M-45	4"	Core: structural clay tile; see Notes 15, 17, 20; No facings.	N/A	1 hr. 15 min.		1		3, 4, 24	1 1/4
W-4-M-46	4"	Core: structural clay tile; see Notes 14, 16, 22; No facings.	N/A	20 min.		1		3, 4, 24	1/3
W-4-M-47	4"	Core: structural clay tile; see Notes 14, 17, 22; No facings.	N/A	25 min.		1		3, 4, 24	1/3
W-4-M-48	4 1/4"	Core: structural clay tile; see Notes 12, 16, 21; Facings: both sides; see Note 18.	N/A	45 min.		1		3, 4, 24	3/4

(continued)

**TABLE 1.1.2—continued
MASONRY WALLS
4" TO LESS THAN 6" THICK**

ITEM CODE	THICKNESS	CONSTRUCTION DETAILS	PERFORMANCE		REFERENCE NUMBER			NOTES	REC. HOURS
			LOAD	TIME	PRE-BMS-92	BMS-92	POST-BMS-92		
W-4-M-49	4 ¹ / ₄ "	Core: structural clay tile; see Notes 12, 17, 21; Facings: both sides; see Note 18.	N/A	1 hr.		1		3, 4, 24	1
W-4-M-50	4 ⁵ / ₈ "	Core: structural clay tile; see Notes 12, 16, 21; Facings: unexposed side only; see Note 18.	N/A	25 min.		1		3, 4, 24	1/3
W-4-M-51	4 ⁵ / ₈ "	Core: structural clay tile; see Notes 12, 17, 21; Facings: unexposed side only; see Note 18.	N/A	30 min.		1		3, 4, 24	1/2
W-4-M-52	4 ⁵ / ₈ "	Core: structural clay tile; see Notes 12, 16, 21; Facings: unexposed side only; see Note 18.	N/A	45 min.		1		3, 4, 24	3/4
W-4-M-53	4 ⁵ / ₈ "	Core: structural clay tile; see Notes 12, 17, 21; Facings: fire side only; see Note 18.	N/A	1 hr.		1		3, 4, 24	1
W-4-M-54	4 ⁵ / ₈ "	Core: structural clay tile; see Notes 12, 16, 20; Facings: unexposed side; see Note 18.	N/A	20 min.		1		3, 4, 24	1/3
W-4-M-55	4 ⁵ / ₈ "	Core: structural clay tile; see Notes 12, 17, 20; Facings: exposed side; see Note 18.	N/A	25 min.		1		3, 4, 24	1/3
W-4-M-56	4 ⁵ / ₈ "	Core: structural clay tile; see Notes 12, 16, 20; Facings: fire side only; see Note 18.	N/A	30 min.		1		3, 4, 24	1/2
W-4-M-57	4 ⁵ / ₈ "	Core: structural clay tile; see Notes 12, 17, 20; Facings: fire side only; see Note 18.	N/A	45 min.		1		3, 4, 24	3/4
W-4-M-58	4 ⁵ / ₈ "	Core: structural clay tile; see Notes 13, 16, 23; Facings: unexposed side only; see Note 18.	N/A	40 min.		1		3, 4, 24	2/3
W-4-M-59	4 ⁵ / ₈ "	Core: structural clay tile; see Notes 13, 17, 23; Facings: unexposed side only; see Note 18.	N/A	1 hr.		1		3, 4, 24	1
W-4-M-60	4 ⁵ / ₈ "	Core: structural clay tile; see Notes 13, 16, 23; Facings: fire side only; see Note 18.	N/A	1 hr. 15 min.		1		3, 4, 24	1 ¹ / ₄
W-4-M-61	4 ⁵ / ₈ "	Core: structural clay tile; see Notes 13, 17, 23; Facings: fire side only; see Note 18.	N/A	1 hr. 30 min.		1		3, 4, 24	1 ¹ / ₂
W-4-M-62	4 ⁵ / ₈ "	Core: structural clay tile; see Notes 13, 16, 21; Facings: unexposed side only; see Note 18.	N/A	35 min.		1		3, 4, 24	1/2
W-4-M-63	4 ⁵ / ₈ "	Core: structural clay tile; see Notes 13, 17, 21; Facings: unexposed face only; see Note 18.	N/A	45 min.		1		3, 4, 24	3/4
W-4-M-64	4 ⁵ / ₈ "	Core: structural clay tile; see Notes 13, 16, 23; Facings: exposed face only; see Note 18.	N/A	1 hr.		1		3, 4, 24	1
W-4-M-65	4 ⁵ / ₈ "	Core: structural clay tile; see Notes 13, 17, 21; Facings: exposed side only; see Note 18.	N/A	1 hr. 15 min.		1		3, 4, 24	1 ¹ / ₄
W-4-M-66	4 ⁵ / ₈ "	Core: structural clay tile; see Notes 15, 17, 20; Facings: unexposed side only; see Note 18.	N/A	1 hr. 30 min.		1		3, 4, 24	1 ¹ / ₂
W-4-M-67	4 ⁵ / ₈ "	Core: structural clay tile; see Notes 15, 16, 20; Facings: exposed side only; see Note 18.	N/A	1 hr. 45 min.		1		3, 4, 24	1 ³ / ₄
W-4-M-68	4 ⁵ / ₈ "	Core: structural clay tile; see Notes 15, 17, 20; Facings: exposed side only; see Note 18.	N/A	1 hr. 45 min.		1		3, 4, 24	1 ³ / ₄
W-4-M-69	4 ⁵ / ₈ "	Core: structural clay tile; see Notes 15, 16, 20; Facings: unexposed side only; see Note 18.	N/A	1 hr. 30 min.		1		3, 4, 24	1 ³ / ₄
W-4-M-70	4 ⁵ / ₈ "	Core: structural clay tile; see Notes 14, 16, 22; Facings: unexposed side only; see Note 18.	N/A	30 min.		1		3, 4, 24	1/2

(continued)

**TABLE 1.1.2—continued
MASONRY WALLS
4" TO LESS THAN 6" THICK**

ITEM CODE	THICKNESS	CONSTRUCTION DETAILS	PERFORMANCE		REFERENCE NUMBER			NOTES	REC. HOURS
			LOAD	TIME	PRE-BMS-92	BMS-92	POST-BMS-92		
W-4-M-71	4 ⁵ / ₈ "	Core: structural clay tile; see Notes 14, 17, 22; Facings: exposed side only; see Note 18.	N/A	35 min.		1		3, 4, 24	1/2
W-4-M-72	4 ⁵ / ₈ "	Core: structural clay tile; see Notes 14, 16, 22; Facings: fire side of wall only; see Note 18.	N/A	45 min.		1		3, 4, 24	3/4
W-4-M-73	4 ⁵ / ₈ "	Core: structural clay tile; see Notes 14, 17, 22; Facings: fire side of wall only; see Note 18.	N/A	1 hr.		1		3, 4, 24	1
W-4-M-74	5 ¹ / ₄ "	Core: structural clay tile; see Notes 12, 16, 21; Facings: both sides; see Note 18.	N/A	1 hr.		1		3, 4, 24	1
W-5-M-75	5 ¹ / ₄ "	Core: structural clay tile; see Notes 12, 17, 21; Facings: both sides; see Note 18	N/A	1 hr. 15 min.		1		3, 4, 24	1 ¹ / ₄
W-5-M-76	5 ¹ / ₄ "	Core: structural clay tile; see Notes 12, 16, 20; Facings: both sides; see Note 18.	N/A	45 min.		1		3, 4, 24	3/4
W-5-M-77	5 ¹ / ₄ "	Core: structural clay tile; see Notes 12, 17, 20; Facings: both sides; see Note 18.	N/A	1 hr.		1		3, 4, 24	1
W-5-M-78	5 ¹ / ₄ "	Core: structural clay tile; see Notes 13, 16, 23; Facings: both sides of wall; see Note 18.	N/A	1 hr. 30 min.		1		3, 4, 24	1 ¹ / ₂
W-5-M-79	5 ¹ / ₄ "	Core: structural clay tile; see Notes 13, 17, 23; Facings: both sides of wall; see Note 18.	N/A	2 hrs.		1		3, 4, 24	2
W-5-M-80	5 ¹ / ₄ "	Core: structural clay tile; see Notes 13, 16, 21; Facings: both sides of wall; see Note 18.	N/A	1 hr. 15 min.		1		3, 4, 24	1 ¹ / ₄
W-5-M-81	5 ¹ / ₄ "	Core: structural clay tile; see Notes 13, 16, 21; Facings: both sides of wall; see Note 18.	N/A	1 hr. 30 min.		1		3, 4, 24	1 ¹ / ₂
W-5-M-82	5 ¹ / ₄ "	Core: structural clay tile; see Notes 15, 16, 20; Facings: both sides; see Note 18.	N/A	2 hrs. 30 min.		1		3, 4, 24	2 ¹ / ₂
W-5-M-83	5 ¹ / ₄ "	Core: structural clay tile; see Notes 15, 17, 20; Facings: both sides; see Note 18.	N/A	2 hrs. 30 min.		1		3, 4, 24	2 ¹ / ₂
W-5-M-84	5 ¹ / ₄ "	Core: structural clay tile; see Notes 14, 16, 22; Facings: both sides of wall; see Note 18.	N/A	1 hr. 15 min.		1		3, 4, 24	1 ¹ / ₄
W-5-M-85	5 ¹ / ₄ "	Core: structural clay tile; see Notes 14, 17, 22; Facings: both sides of wall; see Note 18.	N/A	1 hr. 30 min.		1		3, 4, 24	1 ¹ / ₂
W-4-M-86	4"	Core: 3" thick gypsum blocks 70% solid; see Note 26; Facings: both sides; see Note 25.	N/A	2 hrs.		1			2
W-4-M-87	4"	Core: hollow concrete units; see Notes 27, 34, 35; No facings.	N/A	1 hr. 30 min.		1			1 ¹ / ₂
W-4-M-88	4"	Core: hollow concrete units; see Notes 28, 33, 35; No facings.	N/A	1 hr.		1			1
W-4-M-89	4"	Core: hollow concrete units; see Notes 28, 34, 35; Facings: both sides; see Note 25.	N/A	1 hr. 45 min.		1			1 ³ / ₄
W-4-M-90	4"	Core: hollow concrete units; see Notes 27, 34, 35; Facings: both sides; see Note 25.	N/A	2 hrs.		1			2
W-4-M-91	4"	Core: hollow concrete units; see Notes 27, 32, 35; No facings.	N/A	1 hr. 15 min.		1			1 ¹ / ₄
W-4-M-92	4"	Core: hollow concrete units; see Notes 28, 34, 35; No facings.	N/A	1 hr. 15 min.		1			1 ¹ / ₄
W-4-M-93	4"	Core: hollow concrete units; see Notes 29, 32, 35; No facings.	N/A	20 min.		1			1/3

(continued)

**TABLE 1.1.2—continued
MASONRY WALLS
4" TO LESS THAN 6" THICK**

ITEM CODE	THICKNESS	CONSTRUCTION DETAILS	PERFORMANCE		REFERENCE NUMBER			NOTES	REC. HOURS
			LOAD	TIME	PRE-BMS-92	BMS-92	POST-BMS-92		
W-4-M-94	4"	Core: hollow concrete units; see Notes 30, 34, 35; No facings.	N/A	15 min.		1			1/4
W-4-M-95	4 1/2"	Core: hollow concrete units; see Notes 27, 34, 35; Facings: one side only; see Note 25.	N/A	2 hrs.		1			2
W-4-M-96	4 1/2"	Core: hollow concrete units; see Notes 27, 32, 35; Facings: one side only; see Note 25.	N/A	1 hr. 45 min.		1			1 3/4
W-4-M-97	4 1/2"	Core: hollow concrete units; see Notes 28, 33, 35; Facings: one side; see Note 25.	N/A	1 hr. 30 min.		1			1 1/2
W-4-M-98	4 1/2"	Core: hollow concrete units; see Notes 28, 34, 35; Facings: one side only; see Note 25.	N/A	1 hr. 45 min.		1			1 3/4
W-4-M-99	4 1/2"	Core: hollow concrete units; see Notes 29, 32, 35; Facings: one side; see Note 25.	N/A	30 min.		1			1/2
W-4-M-100	4 1/2"	Core: hollow concrete units; see Notes 30, 34, 35; Facings: one side; see Note 25.	N/A	20 min.		1			1/3
W-5-M-101	5"	Core: hollow concrete units; see Notes 27, 34, 35; Facings: both sides; see Note 25.	N/A	2 hrs. 30 min.		1			2 1/2
W-5-M-102	5"	Core: hollow concrete units; see Notes 27, 32, 35; Facings: both sides; see Note 25.	N/A	2 hrs. 30 min.		1			2 1/2
W-5-M-103	5"	Core: hollow concrete units; see Notes 28, 33, 35; Facings: both sides; see Note 25.	N/A	2 hrs.		1			2
W-5-M-104	5"	Core: hollow concrete units; see Notes 28, 31, 35; Facings: both sides; see Note 25.	N/A	2 hrs.		1			2
W-5-M-105	5"	Core: hollow concrete units; see Notes 29, 32, 35; Facings: both sides; see Note 25.	N/A	1 hr. 45 min.		1			1 3/4
W-5-M-106	5"	Core: hollow concrete units; see Notes 30, 34, 35; Facings: both sides; see Note 25.	N/A	1 hr.		1			1
W-5-M-107	5"	Core: 5" thick solid gypsum blocks; see Note 26; No facings.	N/A	4 hrs.		1			4
W-5-M-108	5"	Core: 4" thick hollow gypsum blocks; see Note 26; Facings: both sides; see Note 25.	N/A	3 hrs.		1			3
W-5-M-109	4"	Concrete with 4" x 4" No. 6 welded wire mesh at wall center.	100 psi	45 min.			43	2	3/4
W-4-M-110	4"	Concrete with 4" x 4" No. 6 welded wire mesh at wall center.	N/A	1 hr. 15 min.			43	2	1 1/4

For SI: 1 inch = 25.4 mm, 1 pound per square inch = 0.00689 MPa.

Notes:

1. Tested as NBS under ASA Spec. No. A 2-1934.
2. Failure mode—maximum temperature rise.
3. Treated at NBS under ASA Spec. No. 42-1934 (ASTM C19-53) except that hose stream testing where carried out was run on test specimens exposed for full test duration, not for or reduced period as is contemporarily done.
4. For clay tile walls, unless the source the clay can be positively identified, it is suggested that the most pessimistic hour rating for the fire endurance of a clay tile partition of that thickness to be followed. Identified sources of clay showing longer fire endurance can lead to longer time recommendations.
5. See appendix for construction and design details for clay tile walls.
6. Failure mode—flame thru or crack formation showing flames.
7. Hole formed at 25 minutes; partition collapsed at 42 minutes or removal from furnace.
8. Failure mode—collapse.
9. Hose stream pass.
10. Hose stream hole formed in specimen.
11. Load: 80 psi for gross wall cross sectional area.
12. One cell in wall thickness.
13. Two cells in wall thickness.

(continued)

**TABLE 1.1.2—continued
MASONRY WALLS
4" TO LESS THAN 6" THICK**

14. Double cells plus one cell in wall thickness.
15. One cell in wall thickness, cells filled with broken tile, crushed stone, slag, cinders or sand mixed with mortar.
16. Dense hard-burned clay or shale tile.
17. Medium-burned clay tile.
18. Not less than $\frac{5}{8}$ inch thickness of 1:3 sanded gypsum plaster.
19. Units of not less than 30 percent solid material.
20. Units of not less than 40 percent solid material.
21. Units of not less than 50 percent solid material.
22. Units of not less than 45 percent solid material.
23. Units of not less than 60 percent solid material.
24. All tiles laid in portland cement-lime mortar.
25. Minimum $\frac{1}{2}$ inch—1:3 sanded gypsum plaster.
26. Laid in 1:3 sanded gypsum mortar. Voids in hollow units not to exceed 30 percent.
27. Units of expanded slag or pumice aggregate.
28. Units of crushed limestone, blast furnace slag, cinders and expanded clay or shale.
29. Units of calcareous sand and gravel. Coarse aggregate, 60 percent or more calcite and dolomite.
30. Units of siliceous sand and gravel. Ninety percent or more quartz, chert or flint.
31. Unit at least 49 percent solid.
32. Unit at least 62 percent solid.
33. Unit at least 65 percent solid.
34. Unit at least 73 percent solid.
35. Ratings based on one unit and one cell in wall thickness.
36. See Clay Tile Partition Design Construction drawings, below.

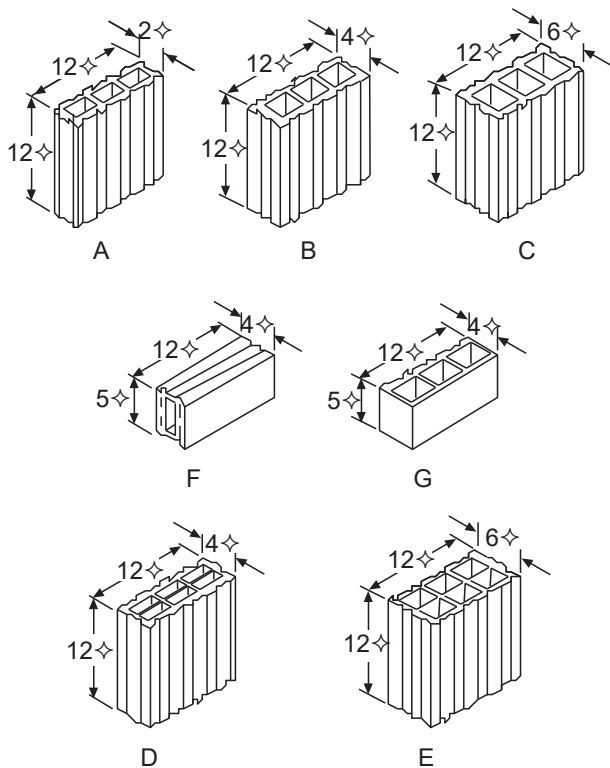

DESIGNS OF TILES USED IN FIRE-TEST PARTITIONS

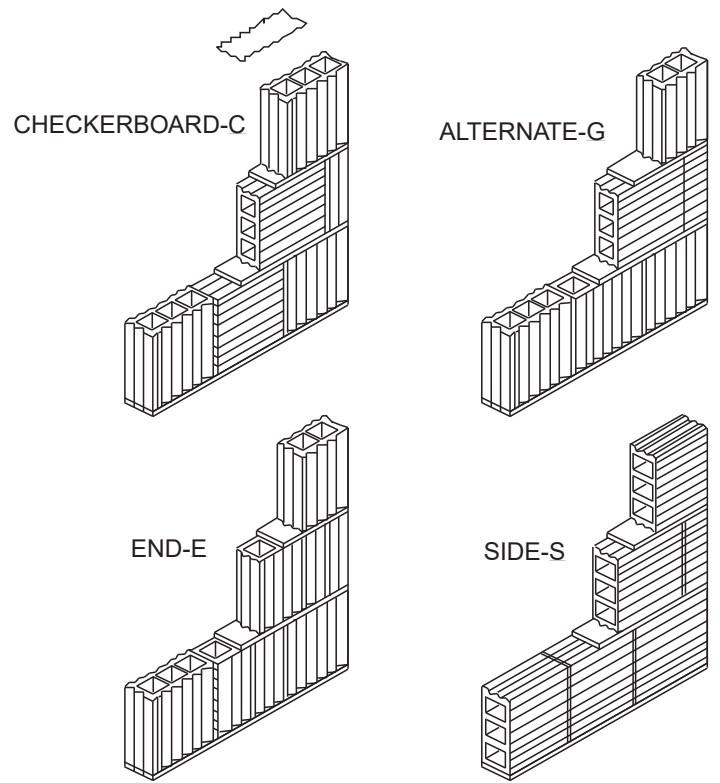

THE FOUR TYPES OF CONSTRUCTION USED IN FIRE-TEST PARTITIONS

**FIGURE 1.1.3
MASONRY WALLS
6" TO LESS THAN 8" THICK**

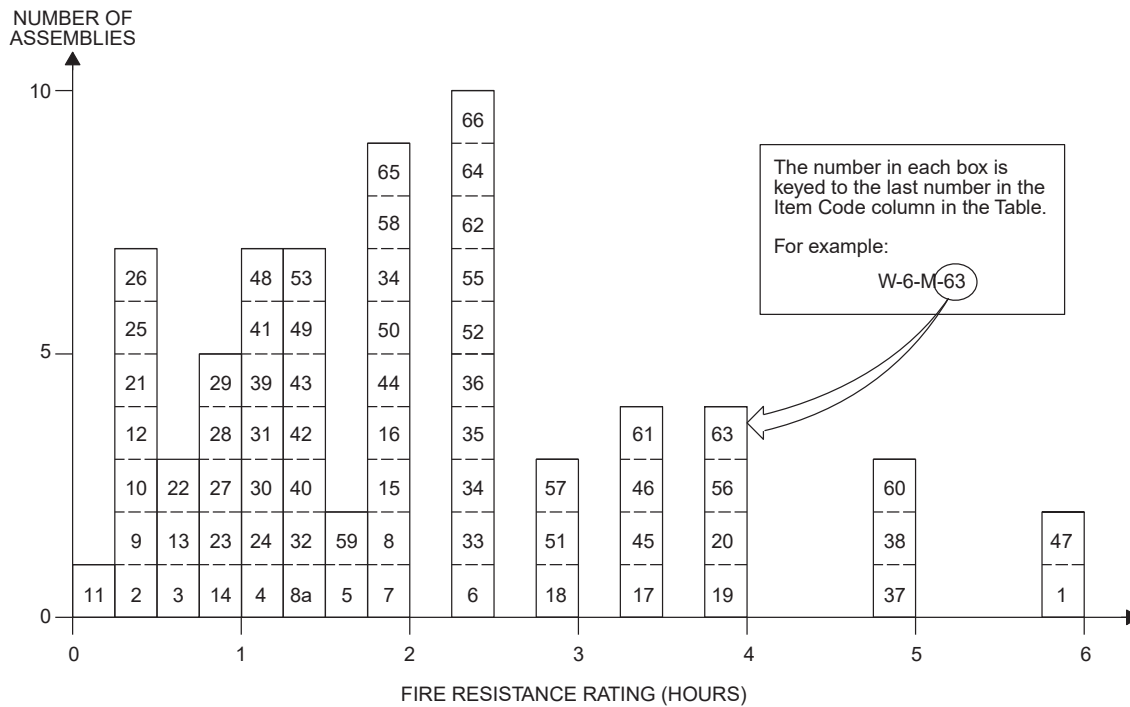

**TABLE 1.1.3
MASONRY WALLS
6" TO LESS THAN 8" THICK**

ITEM CODE	THICKNESS	CONSTRUCTION DETAILS	PERFORMANCE		REFERENCE NUMBER			NOTES	REC. HOURS
			LOAD	TIME	PRE-BMS-92	BMS-92	POST-BMS-92		
W-6-M-1	6"	Core: 5" thick, solid gypsum blocks laid in 1:3 sanded gypsum mortar; 1/2" of 1:3 sanded gypsum plaster facings on both sides.	N/A	6 hrs.		1			6
W-6-M-2	6"	6" clay tile; Ohio fire clay; single cell thick; No plaster; Design "C," Construction "A."	N/A	17 min.			2	1, 3, 4, 6, 55	1/4
W-6-M-3	6"	6" clay tile; Illinois surface clay; double cell thick; No plaster; Design "E," Construction "C."	N/A	45 min.			2	1-4, 7, 55	3/4
W-6-M-4	6"	6" clay tile; New Jersey fire clay; double cell thick; No plaster; Design "E," Construction "S."	N/A	1 hr. 1 min.			2	1-4, 8, 55	1
W-7-M-5	7 1/4"	6" clay tile; Illinois surface clay; double cell thick; Plaster: 5/8"—1:3 sanded gypsum both faces; Design "E," Construction "A."	N/A	1 hr. 41 min.			2	1-4, 55	1 2/3
W-7-M-6	7 1/4"	6" clay tile; New Jersey fire clay; double cell thick; Plaster: 5/8"—1:3 sanded gypsum both faces; Design "E," Construction "S."	N/A	2 hrs. 23 min.			2	1-4, 9, 55	2 1/3
W-7-M-7	7 1/4"	6" clay tile; Ohio fire clay; single cell thick; Plaster: 5/8" sanded gypsum; 1:3 both faces; Design "C," Construction "A."	N/A	1 hr. 54 min.			2	1-4, 9, 55	2 3/4
W-7-M-8	7 1/4"	6" clay tile; Illinois surface clay; single cell thick; Plaster: 5/8" sanded gypsum 1:3 both faces; Design "C," Construction "S."	N/A	2 hrs.			2	1, 3, 4, 9, 10, 55	2
W-7-M-8a	7 1/4"	6" clay tile; Illinois surface clay; single cell thick; Plaster: 5/8" sanded gypsum 1:3 both faces; Design "C," Construction "E."	N/A	1 hr. 23 min			2	1-4, 9, 10, 55	1 3/4

(continued)

**TABLE 1.1.3—continued
MASONRY WALLS
6" TO LESS THAN 8" THICK**

ITEM CODE	THICKNESS	CONSTRUCTION DETAILS	PERFORMANCE		REFERENCE NUMBER			NOTES	REC. HOURS
			LOAD	TIME	PRE-BMS-92	BMS-92	POST-BMS-92		
W-6-M-9	6"	Core: structural clay tile; see Notes 12, 16, 20; No facings.	N/A	20 min.		1		3, 5, 24	1/3
W-6-M-10	6"	Core: structural clay tile; see Notes 12, 17, 20; No facings.	N/A	25 min.		1		3, 5, 24	1/3
W-6-M-11	6"	Core: structural clay tile; see Notes 12, 16, 19; No facings.	N/A	15 min.		1		3, 5, 24	1/4
W-6-M-12	6"	Core: structural clay tile; see Notes 12, 17, 19; No facings.	N/A	20 min.		1		3, 5, 24	1/3
W-6-M-13	6"	Core: structural clay tile; see Notes 13, 16, 22; No facings.	N/A	45 min.		1		3, 5, 24	3/4
W-6-M-14	6"	Core: structural clay tile; see Notes 13, 17, 22; No facings.	N/A	1 hr.		1		3, 5, 24	1
W-6-M-15	6"	Core: structural clay tile; see Notes 15, 17, 19; No facings.	N/A	2 hrs.		1		3, 5, 24	2
W-6-M-16	6"	Core: structural clay tile; see Notes 15, 16, 19; No facings.	N/A	2 hrs.		1		3, 5, 24	2
W-6-M-17	6"	Cored concrete masonry; see Notes 12, 34, 36, 38, 41; No facings.	80 psi	3 hrs. 30 min.		1		5, 25	3 1/2
W-6-M-18	6"	Cored concrete masonry; see Notes 12, 33, 36, 38, 41; No facings.	80 psi	3 hrs.		1		5, 25	3
W-6-M-19	6 1/2"	Cored concrete masonry; see Notes 12, 34, 36, 38, 41; Facings: side 1; see Note 35.	80 psi	4 hrs.		1		5, 25	4
W-6-M-20	6 1/2"	Cored concrete masonry; see Notes 12, 33, 36, 38, 41; Facings: side 1; see Note 35.	80 psi	4 hrs.		1		5, 25	4
W-6-M-21	6 5/8"	Core: structural clay tile; see Notes 12, 16, 20; Facings: unexposed face only; see Note 18.	N/A	30 min.		1		3, 5, 24	1/2
W-6-M-22	6 5/8"	Core: structural clay tile; see Notes 12, 17, 20; Facings: unexposed face only; see Note 18.	N/A	40 min.		1		3, 5, 24	2/3
W-6-M-23	6 5/8"	Core: structural clay tile; see Notes 12, 16, 20; Facings: exposed face only; see Note 18.	N/A	1 hr.		1		3, 5, 24	1
W-6-M-24	6 5/8"	Core: structural clay tile; see Notes 12, 17, 20; Facings: exposed face only; see Note 18.	N/A	1 hr. 5 min.		1		3, 5, 24	1
W-6-M-25	6 5/8"	Core: structural clay tile; see Notes 12, 16, 19; Facings: unexposed side only; see Note 18.	N/A	25 min.		1		3, 5, 24	1/3
W-6-M-26	6 5/8"	Core: structural clay tile; see Notes 12, 7, 19; Facings: unexposed face only; see Note 18.	N/A	30 min.		1		3, 5, 24	1/2
W-6-M-27	6 5/8"	Core: structural clay tile; see Notes 12, 16, 19; Facings: exposed side only; see Note 18.	N/A	1 hr.		1		3, 5, 24	1
W-6-M-28	6 5/8"	Core: structural clay tile; see Notes 12, 17, 19; Facings: fire side only; see Note 18.	N/A	1 hr.		1		3, 5, 24	1
W-6-M-29	6 5/8"	Core: structural clay tile; see Notes 13, 16, 22; Facings: unexposed side only; see Note 18.	N/A	1 hr.		1		3, 5, 24	1
W-6-M-30	6 5/8"	Core: structural clay tile; see Notes 13, 17, 22; Facings: unexposed side only; see Note 18.	N/A	1 hr. 15 min.		1		3, 5, 24	1 1/4
W-6-M-31	6 5/8"	Core: structural clay tile; see Notes 13, 16, 22; Facings: fire side only; see Note 18.	N/A	1 hr. 15 min.		1		3, 5, 24	1 1/4
W-6-M-32	6 5/8"	Core: structural clay tile; see Notes 13, 17, 22; Facings: fire side only; see Note 18.	N/A	1 hr. 30 min.		1		3, 5, 24	1 1/2

(continued)

**TABLE 1.1.3—continued
MASONRY WALLS
6" TO LESS THAN 8" THICK**

ITEM CODE	THICKNESS	CONSTRUCTION DETAILS	PERFORMANCE		REFERENCE NUMBER			NOTES	REC. HOURS
			LOAD	TIME	PRE-BMS-92	BMS-92	POST-BMS-92		
W-6-M-33	6 ⁵ / ₈ "	Core: structural clay tile; see Notes 15, 16, 19; Facings: unexposed side only; see Note 18.	N/A	2 hrs. 30 min.		1		3, 5, 24	2 ¹ / ₂
W-6-M-34	6 ⁵ / ₈ "	Core: structural clay tile; see Notes 15, 17, 19; Facings: unexposed side only; see Note 18.	N/A	2 hrs. 30 min.		1		3, 5, 24	2 ¹ / ₂
W-6-M-35	6 ⁵ / ₈ "	Core: structural clay tile; see Notes 15, 16, 19; Facings: fire side only; see Note 18.	N/A	2 hrs. 30 min.		1		3, 5, 24	2 ¹ / ₂
W-6-M-36	6 ⁵ / ₈ "	Core: structural clay tile; see Notes 15, 17, 19; Facings: fire side only; see Note 18.	N/A	2 hrs. 30 min.		1		3, 5, 24	2 ¹ / ₂
W-6-M-37	7"	Cored concrete masonry; see Notes 12, 34, 36, 38, 41; see Note 35 for facings on both sides.	80 psi	5 hrs.		1		5, 25	5
W-6-M-38	7"	Cored concrete masonry; see Notes 12, 33, 36, 38, 41; see Note 35 for facings.	80 psi	5 hrs.		1		5, 25	5
W-6-M-39	7 ¹ / ₄ "	Core: structural clay tile; see Notes 12, 16, 20; Facings: both sides; see Note 18.	N/A	1 hr. 15 min.		1		3, 5, 24	1 ¹ / ₄
W-6-M-40	7 ¹ / ₄ "	Core: structural clay tile; see Notes 12, 17, 20; Facings: both sides; see Note 18.	N/A	1 hr. 30 min.		1		3, 5, 24	1 ¹ / ₂
W-6-M-41	7 ¹ / ₄ "	Core: structural clay tile; see Notes 12, 16, 19; Facings: both sides; see Note 18.	N/A	1 hr. 15 min.		1		3, 5, 24	1 ¹ / ₄
W-6-M-42	7 ¹ / ₄ "	Core: structural clay tile; see Notes 12, 17, 19; Facings: both sides; see Note 18.	N/A	1 hr. 30 min.		1		3, 5, 24	1 ¹ / ₂
W-7-M-43	7 ¹ / ₄ "	Core: structural clay tile; see Notes 13, 16, 22; Facings: both sides of wall; see Note 18.	N/A	1 hr. 30 min.		1		3, 5, 24	1 ¹ / ₂
W-7-M-44	7 ¹ / ₄ "	Core: structural clay tile; see Notes 13, 17, 22; Facings: both sides of wall; see Note 18.	N/A	2 hrs.		1		3, 5, 24	1 ¹ / ₂
W-7-M-45	7 ¹ / ₄ "	Core: structural clay tile; see Notes 15, 16, 19; Facings: both sides; see Note 18.	N/A	3 hrs. 30 min.		1		3, 5, 24	3 ¹ / ₂
W-7-M-46	7 ¹ / ₄ "	Core: structural clay tile; see Notes 15, 17, 19; Facings: both sides; see Note 18.	N/A	3 hrs. 30 min.		1		3, 5, 24	3 ¹ / ₂
W-6-M-47	6"	Core: 5" thick solid gypsum blocks; see Note 45; Facings: both sides; see Note 45.	N/A	6 hrs.		1			6
W-6-M-48	6"	Core: hollow concrete units; see Notes 47, 50, 54; No facings.	N/A	1 hr. 15 min.		1			1 ¹ / ₄
W-6-M-49	6"	Core: hollow concrete units; see Notes 46, 50, 54; No facings.	N/A	1 hr. 30 min.		1			1 ¹ / ₂
W-6-M-50	6"	Core: hollow concrete units; see Notes 46, 41, 54; No facings.	N/A	2 hrs.		1			2
W-6-M-51	6"	Core: hollow concrete units; see Notes 46, 53, 54; No facings.	N/A	3 hrs.		1			3
W-6-M-52	6"	Core: hollow concrete units; see Notes 47, 53, 54; No facings.	N/A	2 hrs. 30 min.		1			2 ¹ / ₂
W-6-M-53	6"	Core: hollow concrete units; see Notes 47, 51, 54; No facings.	N/A	1 hr. 30 min.		1			1 ¹ / ₂
W-6-M-54	6 ¹ / ₂ "	Core: hollow concrete units; see Notes 46, 50, 54; Facings: one side only; see Note 35.	N/A	2 hrs.		1			2
W-6-M-55	6 ¹ / ₂ "	Core: hollow concrete units; see Notes 4, 51, 54; Facings: one side; see Note 35.	N/A	2 hrs. 30 min.		1			2 ¹ / ₂
W-6-M-56	6 ¹ / ₂ "	Core: hollow concrete units; see Notes 46, 53, 54; Facings: one side; see Note 35.	N/A	4 hrs.		1			4

(continued)

**TABLE 1.1.3—continued
MASONRY WALLS
6" TO LESS THAN 8" THICK**

ITEM CODE	THICKNESS	CONSTRUCTION DETAILS	PERFORMANCE		REFERENCE NUMBER			NOTES	REC. HOURS
			LOAD	TIME	PRE-BMS-92	BMS-92	POST-BMS-92		
W-6-M-57	6½"	Core: hollow concrete units; see Notes 47, 53, 54; Facings: one side; see Note 35.	N/A	3 hrs.		1			3
W-6-M-58	6½"	Core: hollow concrete units; see Notes 47, 51, 54; Facings: one side; see Note 35.	N/A	2 hrs.		1			2
W-6-M-59	6½"	Core: hollow concrete units; see Notes 47, 50, 54; Facings: one side; see Note 35.	N/A	1 hr. 45 min.		1			1¾
W-7-M-60	7"	Core: hollow concrete units; see Notes 46, 53, 54; Facings: both sides; see Note 35.	N/A	5 hrs.		1			5
W-7-M-61	7"	Core: hollow concrete units; see Notes 46, 51, 54; Facings: both sides; see Note 35.	N/A	3 hrs. 30 min.		1			3½
W-7-M-62	7"	Core: hollow concrete units; see Notes 46, 50, 54; Facings: both sides; see Note 35.	N/A	2 hrs. 30 min.		1			2½
W-7-M-63	7"	Core: hollow concrete units; see Notes 47, 53, 54; Facings: both sides; see Note 35.	N/A	4 hrs.		1			4
W-7-M-64	7"	Core: hollow concrete units; see Notes 47, 51, 54; Facings: both sides; see Note 35.	N/A	2 hrs. 30 min.		1			2½
W-7-M-65	7"	Core: hollow concrete units; see Notes 47, 50, 54; Facings: both sides; see Note 35.	N/A	2 hrs.		1			2
W-6-M-66	6"	Concrete wall with 4" × 4" No. 6 wire fabric (welded) near wall center for reinforcement.	N/A	2 hrs. 30 min.			43	2	2½

For SI: 1 inch = 25.4 mm, 1 pound per square inch = 0.00689 MPa.

Notes:

1. Tested at NBS under ASA Spec. No. 43-1934 (ASTM C19-53) except that hose stream testing where carried out was run on test specimens exposed for full test duration, not for a reduced period as is contemporarily done.
2. Failure by thermal criteria—maximum temperature rise.
3. For clay tile walls, unless the source or density of the clay can be positively identified or determined, it is suggested that the lowest hourly rating for the fire endurance of a clay tile partition of that thickness be followed. Identified sources of clay showing longer fire endurance can lead to longer time recommendations.
4. See Note 55 for construction and design details for clay tile walls.
5. Tested at NBS under ASA Spec. No. A2-1934.
6. Failure mode—collapse.
7. Collapsed on removal from furnace at 1 hour 9 minutes.
8. Hose stream—failed.
9. Hose stream—passed.
10. No end point met in test.
11. Wall collapsed at 1 hour 28 minutes.
12. One cell in wall thickness.
13. Two cells in wall thickness.
14. Double shells plus one cell in wall thickness.
15. One cell in wall thickness, cells filled with broken tile, crushed stone, slag, cinders or sand mixed with mortar.
16. Dense hard-burned clay or shale tile.
17. Medium-burned clay tile.
18. Not less than 5/8 inch thickness of 1:3 sanded gypsum plaster.
19. Units of not less than 30 percent solid material.
20. Units of not less than 40 percent solid material.
21. Units of not less than 50 percent solid material.
22. Units of not less than 45 percent solid material.
23. Units of not less than 60 percent solid material.
24. All tiles laid in portland cement-lime mortar.
25. Load: 80 psi for gross cross sectional area of wall.
26. Three cells in wall thickness.
27. Minimum percent of solid material in concrete units = 52.
28. Minimum percent of solid material in concrete units = 54.
29. Minimum percent of solid material in concrete units = 55.
30. Minimum percent of solid material in concrete units = 57.

(continued)

**TABLE 1.1.3—continued
MASONRY WALLS
6" TO LESS THAN 8" THICK**

31. Minimum percent of solid material in concrete units = 62.
32. Minimum percent of solid material in concrete units = 65.
33. Minimum percent of solid material in concrete units = 70.
34. Minimum percent of solid material in concrete units = 76.
35. Not less than 1/2 inch of 1:3 sanded gypsum plaster.
36. Noncombustible or no members framed into wall.
37. Combustible members framed into wall.
38. One unit in wall thickness.
39. Two units in wall thickness.
40. Three units in wall thickness.
41. Concrete units made with expanded slag or pumice aggregates.
42. Concrete units made with expanded burned clay or shale, crushed limestone, air cooled slag or cinders.
43. Concrete units made with calcareous sand and gravel. Coarse aggregate, 60 percent or more calcite and dolomite.
44. Concrete units made with siliceous sand and gravel. Ninety percent or more quartz, chert or flint.
45. Laid in 1:3 sanded gypsum mortar.
46. Units of expanded slag or pumice aggregate.
47. Units of crushed limestone, blast furnace, slag, cinder and expanded clay or shale.
48. Units of calcareous sand and gravel. Coarse aggregate, 60 percent or more calcite and dolomite.
49. Units of siliceous sand and gravel. Ninety percent or more quartz, chert or flint.
50. Unit minimum 49 percent solid.
51. Unit minimum 62 percent solid.
52. Unit minimum 65 percent solid.
53. Unit minimum 73 percent solid.
54. Ratings based on one unit and one cell in wall section.
55. See Clay Tile Partition Design Construction drawings, below.

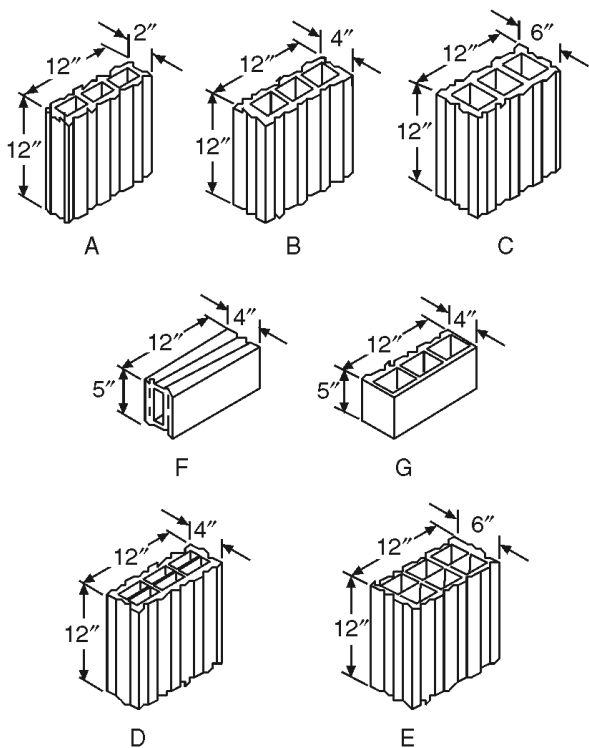

DESIGNS OF TILES USED IN FIRE-TEST PARTITIONS

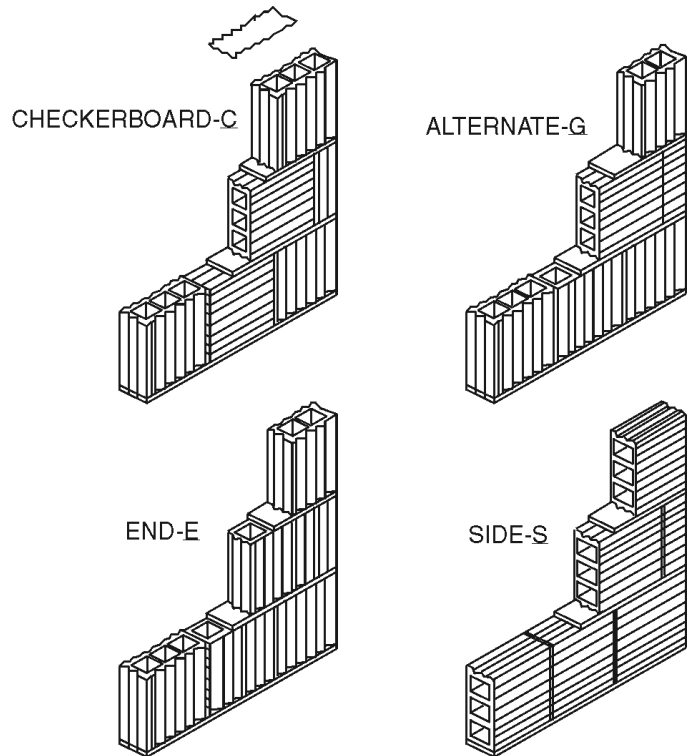

THE FOUR TYPES OF CONSTRUCTION USED IN FIRE-TEST PARTITIONS

**FIGURE 1.1.4
MASONRY WALLS
8" TO LESS THAN 10" THICK**

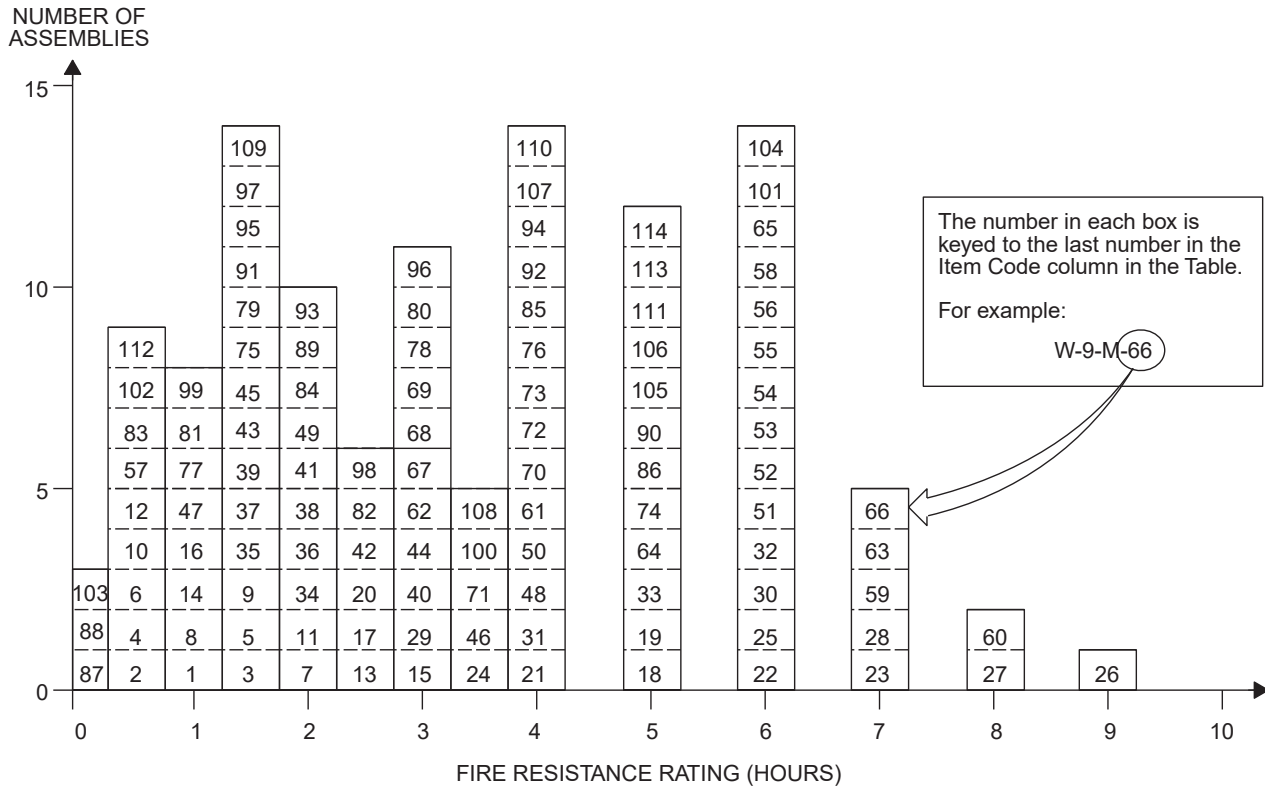

**TABLE 1.1.4
MASONRY WALLS
8" TO LESS THAN 10" THICK**

ITEM CODE	THICKNESS	CONSTRUCTION DETAILS	PERFORMANCE		REFERENCE NUMBER			NOTES	REC. HOURS
			LOAD	TIME	PRE-BMS-92	BMS-92	POST-BMS-92		
W-8-M-1	8"	Core: clay or shale structural tile; Units in wall thickness: 1; Cells in wall thickness: 2; Minimum % solids in units: 40.	80 psi	1 hr. 15 min.		1		1, 20	1 ¹ / ₄
W-8-M-2	8"	Core: clay or shale structural tile; Units in wall thickness: 1; Cells in wall thickness: 2; Minimum % solids in units: 40; No facings; Result for wall with combustible members framed into interior.	80 psi	45 min.		1		1, 20	3/4
W-8-M-3	8"	Core: clay or shale structural tile; Units in wall thickness: 1; Cells in wall thickness: 2; Minimum % solids in units: 43.	80 psi	1 hr. 30 min.		1		1, 20	1 ¹ / ₂
W-8-M-4	8"	Core: clay or shale structural tile; Units in wall thickness: 1; Cells in wall thickness: 2; Minimum % solids in units: 43; No facings; Combustible members framed into wall.	80 psi	45 min.		1		1, 20	3/4
W-8-M-5	8"	Core: clay or shale structural tile; No facings.	See Notes	1 hr. 30 min.		1		1, 2, 5, 10, 18, 20, 21	1 ¹ / ₂
W-8-M-6	8"	Core: clay or shale structural tile; No facings.	See Notes	45 min.		1		1, 2, 5, 10, 19, 20, 21	3/4

(continued)

**TABLE 1.1.4—continued
MASONRY WALLS
8" TO LESS THAN 10" THICK**

ITEM CODE	THICKNESS	CONSTRUCTION DETAILS	PERFORMANCE		REFERENCE NUMBER			NOTES	REC. HOURS
			LOAD	TIME	PRE-BMS-92	BMS-92	POST-BMS-92		
W-8-M-7	8"	Core: clay or shale structural tile; No facings	See Notes	2 hrs.		1		1, 2, 5, 13, 18, 20, 21	2
W-8-M-8	8"	Core: clay or shale structural tile; No facings.	See Notes	1 hr. 45 min.		1		1, 2, 5, 13, 19, 20, 21	1 ¹ / ₄
W-8-M-9	8"	Core: clay or shale structural tile; No facings.	See Notes	1 hr. 15 min.		1		1, 2, 6, 9, 18, 20, 21	1 ³ / ₄
W-8-M-10	8"	Core: clay or shale structural tile; No facings.	See Notes	45 min.		1		1, 2, 6, 9, 19, 20, 21	³ / ₄
W-8-M-11	8"	Core: clay or shale structural tile; No facings.	See Notes	2 hrs.		1		1, 2, 6, 10, 18, 20, 21	2
W-8-M-12	8"	Core: clay or shale structural tile; No facings.	See Notes	45 min.		1		1, 2, 6, 10, 19, 20, 21	³ / ₄
W-8-M-13	8"	Core: clay or shale structural tile; No facings.	See Notes	2 hrs. 30 min.		1		1, 3, 6, 12, 18, 20, 21	2 ¹ / ₂
W-8-M-14	8"	Core: clay or shale structural tile; No facings.	See Notes	1 hr.		1		1, 2, 6, 12, 19, 20, 21	1
W-8-M-15	8"	Core: clay or shale structural tile; No facings.	See Notes	3 hrs.		1		1, 2, 6, 16, 18, 20, 21	3
W-8-M-16	8"	Core: clay or shale structural tile; No facings.	See Notes	1 hr. 15 min.		1		1, 2, 6, 16, 19, 20, 21	1 ¹ / ₄
W-8-M-17	8"	Cored clay or shale brick; Units in wall thickness: 1; Cells in wall thickness: 1; Minimum % solids: 70; No facings.	See Notes	2 hrs. 30 min.		1		1, 44	2 ¹ / ₂
W-8-M-18	8"	Cored clay or shale brick; Units in wall thickness: 2; Cells in wall thickness: 2; Minimum % solids: 87; No facings.	See Notes	5 hrs.		1		1, 45	5
W-8-M-19	8"	Core: solid clay or shale brick; No facings.	See Notes	5 hrs.		1		1, 22, 45	5
W-8-M-20	8"	Core: hollow rolok of clay or shale.	See Notes	2 hrs. 30 min.		1		1, 22, 45	2 ¹ / ₂
W-8-M-21	8"	Core: hollow rolok bak of clay or shale; No facings.	See Notes	4 hrs.		1		1, 45	4
W-8-M-22	8"	Core: concrete brick; No facings.	See Notes	6 hrs.		1		1, 45	6
W-8-M-23	8"	Core: sand-lime brick; No facings.	See Notes	7 hrs.		1		1, 45	7
W-8-M-24	8"	Core: 4", 40% solid clay or shale structural tile; 1 side 4" brick facing.	See Notes	3 hrs. 30 min.		1		1, 20	3 ¹ / ₂
W-8-M-25	8"	Concrete wall (3220 psi); Reinforcing vertical rods 1" from each face and 1" diameter; horizontal rods ⁵ / ₈ " diameter.	22,200 lbs./ft.	6 hrs.			7		6
W-8-M-26	8"	Core: sand-line brick; ¹ / ₂ " of 1:3 sanded gypsum plaster facings on one side.	See Notes	9 hrs.		1		1, 45	9
W-8-M-27	8 ¹ / ₂ "	Core: sand-line brick; ¹ / ₂ " of 1:3 sanded gypsum plaster facings on one side.	See Notes	8 hrs.		1		1, 45	8
W-8-M-28	8 ¹ / ₂ "	Core: concrete; ¹ / ₂ " of 1:3 sanded gypsum plaster facings on one side.	See Notes	7 hrs.		1		1, 45	7

(continued)

**TABLE 1.1.4—continued
MASONRY WALLS
8" TO LESS THAN 10" THICK**

ITEM CODE	THICKNESS	CONSTRUCTION DETAILS	PERFORMANCE		REFERENCE NUMBER			NOTES	REC. HOURS
			LOAD	TIME	PRE-BMS-92	BMS-92	POST-BMS-92		
W-8-M-29	8½"	Core: hollow rolok of clay or shale; ½" of 1:3 sanded gypsum plaster facings on one side.	See Notes	3 hrs.		1		1, 45	3
W-8-M-30	8½"	Core: solid clay or shale brick ½" thick, 1:3 sanded gypsum plaster facings on one side.	See Notes	6 hrs.		1		1, 22, 45,	6
W-8-M-31	8½"	Core: cored clay or shale brick; Units in wall thickness: 1; Cells in wall thickness: 1; Minimum % solids: 70; ½" of 1:3 sanded gypsum plaster facings on both sides.	See Notes	4 hrs.		1		1, 44	4
W-8-M-32	8½"	Core: cored clay or shale brick; Units in wall thickness: 2; Cells in wall thickness: 2; Minimum % solids: 87; ½" of 1:3 sanded gypsum plaster facings on one side.	See Notes	6 hrs.		1		1, 45	6
W-8-M-33	8½"	Core: hollow rolok bak of clay or shale; ½" of 1:3 sanded gypsum plaster facings on one side.	See Notes	5 hrs.		1		1, 45	5
W-8-M-34	8⅝"	Core: clay or shale structural tile; Units in wall thickness: 1; Cells in wall thickness: 2; Minimum % solids in units: 40; ⅝" of 1:3 sanded gypsum plaster facings on one side.	See Notes	2 hrs.		1		1, 20, 21	2
W-8-M-35	8⅝"	Core: clay or shale structural tile; Units in wall thickness: 1; Cells in wall thickness: 2; Minimum % solids in units: 40; Exposed face: ⅝" of 1:3 sanded gypsum plaster.	See Notes	1 hr. 30 min.		1		1, 20, 21	1½
W-8-M-36	8⅝"	Core: clay or shale structural tile; Units in wall thickness: 1; Cells in wall thickness: 2; Minimum % solids in units: 43; ⅝" of 1:3 sanded gypsum plaster facings on one side.	See Notes	2 hrs.				1, 20, 21	2
W-8-M-37	8⅝"	Core: clay or shale structural tile; Units in wall thickness: 1; Cells in wall thickness: 2; Minimum % solids in units: 43; ⅝" of 1:3 sanded gypsum plaster of the exposed face only.	See Notes	1 hr. 30 min.		1		1, 20, 21	1½
W-8-M-38	8⅝"	Core: clay or shale structural tile; Facings: side 1; see Note 17.	See Notes	2 hrs.		1		1, 2, 5, 10, 18, 20, 21	2
W-8-M-39	8⅝"	Core: clay or shale structural tile; Facings: exposed side only; see Note 17.	See Notes	1 hr. 30 min.		1		1, 2, 5, 10, 19, 20, 21	1½
W-8-M-40	8⅝"	Core: clay or shale structural tile; Facings: exposed side only; see Note 17.	See Notes	3 hrs.		1		1, 2, 5, 13, 18, 20, 21	3
W-8-M-41	8⅝"	Core: clay or shale structural tile; Facings: exposed side only; see Note 17.	See Notes	2 hrs.		1		1, 2, 5, 13, 19, 20, 21	2
W-8-M-42	8⅝"	Core: clay or shale structural tile; Facings: side 1; see Note 17.	See Notes	2 hrs. 30 min.		1		1, 2, 9, 18, 20, 21	2½
W-8-M-43	8⅝"	Core: clay or shale structural tile; Facings: exposed side only; see Note 17.	See Notes	1 hr. 30 min.		1		1, 2, 6, 9, 19, 20, 21	1½

(continued)

**TABLE 1.1.4—continued
MASONRY WALLS
8" TO LESS THAN 10" THICK**

ITEM CODE	THICKNESS	CONSTRUCTION DETAILS	PERFORMANCE		REFERENCE NUMBER			NOTES	REC. HOURS
			LOAD	TIME	PRE-BMS-92	BMS-92	POST-BMS-92		
W-8-M-44	8 ⁵ / ₈ "	Core: clay or shale structural tile; Facings: side 1, see Note 17; side 2, none.	See Notes	3 hrs.		1		1, 2, 10, 18, 20, 21	3
W-8-M-45	8 ⁵ / ₈ "	Core: clay or shale structural tile; Facings: fire side only; see Note 17.	See Notes	1 hr. 30 min.		1		1, 2, 6, 10, 19, 20, 21	1 ¹ / ₂
W-8-M-46	8 ⁵ / ₈ "	Core: clay or shale structural tile; Facings: side 1, see Note 17; side 2, none.	See Notes	3 hrs. 30 min.		1		1, 2, 6, 12, 18, 20, 21	3 ¹ / ₂
W-8-M-47	8 ⁵ / ₈ "	Core: clay or shale structural tile; Facings: exposed side only; see Note 17.	See Notes	1 hr. 45 min.		1		1, 2, 6, 12, 19, 20, 21	1 ³ / ₄
W-8-M-48	8 ⁵ / ₈ "	Core: clay or shale structural tile; Facings: side 1, see Note 17; side 2, none.	See Notes	4 hrs.		1		1, 2, 6, 16, 18, 20, 21	4
W-8-M-49	8 ⁵ / ₈ "	Core: clay or shale structural tile; Facings: fire side only; see Note 17.	See Notes	2 hrs.		1		1, 2, 6, 16, 19, 20, 21	2
W-8-M-50	8 ⁵ / ₈ "	Core: 4", 40% solid clay or shale clay structural tile; 4" brick plus ⁵ / ₈ " of 1:3 sanded gypsum plaster facings on one side.	See Notes	4 hrs.		1		1, 20	4
W-8-M-51	8 ³ / ₄ "	8 ³ / ₄ " × 2 ¹ / ₂ " and 4" × 2 ¹ / ₂ " cellular fletton (1873 psi) single and triple cell hollow brick set in ¹ / ₂ " sand mortar in alternate courses.	3.6 tons/ft.	6 hrs.			7	23, 29	6
W-8-M-52	8 ³ / ₄ "	8 ³ / ₄ " thick cement brick (2527 psi) with P.C. and sand mortar.	3.6 tons/ft.	6 hrs.			7	23, 24	6
W-8-M-53	8 ³ / ₄ "	8 ³ / ₄ " × 2 ¹ / ₂ " fletton brick (1831 psi) in ¹ / ₂ " sand mortar.	3.6 tons/ft.	6 hrs.			7	23, 24	6
W-8-M-54	8 ³ / ₄ "	8 ³ / ₄ " × 2 ¹ / ₂ " London stock brick (683 psi) in ¹ / ₂ " P.C. - sand mortar.	7.2 tons/ft.	6 hrs.			7	23, 24	6
W-9-M-55	9"	9" × 2 ¹ / ₂ " Leicester red wire-cut brick (4465 psi) in ¹ / ₂ " P.C. - sand mortar.	6.0 tons/ft.	6 hrs.			7	23, 24	6
W-9-M-56	9"	9" × 3" sand-lime brick (2603 psi) in ¹ / ₂ " P.C. - sand mortar.	3.6 tons/ft.	6 hrs.			7	23, 24	6
W-9-M-57	9"	2 layers 2 ⁷ / ₈ " fletton brick (1910 psi) with 3 ¹ / ₄ " air space; Cement and sand mortar.	1.5 tons/ft.	32 min.			7	23, 25	¹ / ₃
W-9-M-58	9"	9" × 3" stairfoot brick (7527 psi) in ¹ / ₂ " sand-cement mortar.	7.2 tons/ft.	6 hrs.			7	23, 24	6
W-9-M-59	9"	Core: solid clay or shale brick; ¹ / ₂ " thick; 1:3 sanded gypsum plaster facings on both sides.	See Notes	7 hrs.		1		1, 22, 45	7
W-9-M-60	9"	Core: concrete brick; ¹ / ₂ " of 1:3 sanded gypsum plaster facings on both sides.	See Notes	8 hrs.		1		1, 45	8
W-9-M-61	9"	Core: hollow rolok of clay or shale; ¹ / ₂ " of 1:3 sanded gypsum plaster facings on both sides.	See Notes	4 hrs.		1		1, 45	4
W-9-M-62	9"	Cored clay or shale brick; Units in wall thickness: 1; Cells in wall thickness: 1; Minimum % solids: 70; ¹ / ₂ " of 1:3 sanded gypsum plaster facings on one side.	See Notes	3 hrs.		1		1, 44	3

(continued)

**TABLE 1.1.4—continued
MASONRY WALLS
8" TO LESS THAN 10" THICK**

ITEM CODE	THICKNESS	CONSTRUCTION DETAILS	PERFORMANCE		REFERENCE NUMBER			NOTES	REC. HOURS
			LOAD	TIME	PRE-BMS-92	BMS-92	POST-BMS-92		
W-9-M-63	9"	Cored clay or shale brick; Units in wall thickness: 2; Cells in wall thickness: 2; Minimum % solids: 87; 1/2" of 1:3 sanded gypsum plaster facings on both sides.	See Notes	7 hrs.		1		1, 45	7
W-9-M-64	9-10"	Core: cavity wall of clay or shale brick; No facings.	See Notes	5 hrs.		1		1, 45	5
W-9-M-65	9-10"	Core: cavity construction of clay or shale brick; 1/2" of 1:3 sanded gypsum plaster facings on one side.	See Notes	6 hrs.		1		1, 45	6
W-9-M-66	9-10"	Core: cavity construction of clay or shale brick; 1/2" of 1:3 sanded gypsum plaster facings on both sides.	See Notes	7 hrs.		1		1, 45	7
W-9-M-67	9 1/4"	Core: clay or shale structural tile; Units in wall thickness: 1; Cells in wall thickness: 2; Minimum % solids in units: 40; 5/8" of 1:3 sanded gypsum plaster facings on both sides.	See Notes	3 hrs.		1		1, 20, 21	3
W-9-M-68	9 1/4"	Core: clay or shale structural tile; Units in wall thickness: 1; Cells in wall thickness: 2; Minimum % solids in units: 43; 5/8" of 1:3 sanded gypsum plaster facings on both sides.	See Notes	3 hrs.		1		1, 20, 21	3
W-9-M-69	9 1/4"	Core: clay or shale structural tile; Facings: sides 1 and 2; see Note 17.	See Notes	3 hrs.		1		1, 2, 5, 10, 18, 20, 21	3
W-9-M-70	9 1/4"	Core: clay or shale structural tile; Facings: sides 1 and 2; see Note 17.	See Notes	4 hrs.		1		1, 2, 5, 13, 18, 20, 21	4
W-9-M-71	9 1/4"	Core: clay or shale structural tile; Facings: sides 1 and 2; see Note 17.	See Notes	3 hrs. 30 min.		1		1, 2, 6, 9, 18, 20, 21	3 1/2
W-9-M-72	9 1/4"	Core: clay or shale structural tile; Facings: sides 1 and 2; see Note 17.	See Notes	4 hrs.		1		1, 2, 6, 10, 18, 20, 21	4
W-9-M-73	9 1/4"	Core: clay or shale structural tile; Facings: sides 1 and 2; see Note 17.	See Notes	4 hrs.		1		1, 2, 6, 12, 18, 20, 21	4
W-9-M-74	9 1/4"	Core: clay or shale structural tile; Facings: sides 1 and 2; see Note 17.	See Notes	5 hrs.		1		1, 2, 6, 16, 18, 20, 21	5
W-9-M-75	8"	Cored concrete masonry; see Notes 2, 19, 26, 34, 40; No facings.	80 psi	1 hr. 30 min.		1		1, 20	1 1/2
W-8-M-76	8"	Cored concrete masonry; see Notes 2, 18, 26, 34, 40; No facings	80 psi	4 hrs.		1		1, 20	4
W-8-M-77	8"	Cored concrete masonry; see Notes 2, 19, 26, 31, 40; No facings.	80 psi	1 hr. 15 min.		1		1, 20	1 1/4
W-8-M-78	8"	Cored concrete masonry; see Notes 2, 18, 26, 31, 40; No facings.	80 psi	3 hrs.		1		1, 20	3
W-8-M-79	8"	Cored concrete masonry; see Notes 2, 19, 26, 36, 42; No facings.	80 psi	1 hr. 30 min.		1		1, 20	1 1/2

(continued)

**TABLE 1.1.4—continued
MASONRY WALLS
8" TO LESS THAN 10" THICK**

ITEM CODE	THICKNESS	CONSTRUCTION DETAILS	PERFORMANCE		REFERENCE NUMBER			NOTES	REC. HOURS
			LOAD	TIME	PRE-BMS-92	BMS-92	POST-BMS-92		
W-8-M-80	8"	Cored concrete masonry; see Notes 2, 18, 26, 36, 41; No facings.	80 psi	3 hrs.		1		1, 20	3
W-8-M-81	8"	Cored concrete masonry; see Notes 2, 19, 26, 34, 41; No facings.	80 psi	1 hr.		1		1, 20	1
W-8-M-82	8"	Cored concrete masonry; see Notes 2, 18, 26, 34, 41; No facings.	80 psi	2 hrs. 30 min.		1		1, 20	2½
W-8-M-83	8"	Cored concrete masonry; see Notes 2, 19, 26, 29, 41; No facings.	80 psi	45 min.		1		1, 20	¾
W-8-M-84	8"	Cored concrete masonry; see Notes 2, 18, 26, 29, 41; No facings.	80 psi	2 hrs.		1		1, 20	2
W-8-M-85	8½"	Cored concrete masonry; see Notes 3, 18, 26, 34, 41; Facings: 2¼" brick.	80 psi	4 hrs.		1		1, 20	4
W-8-M-86	8"	Cored concrete masonry; see Notes 3, 18, 26, 34, 41; Facings: 3¾" brick face.	80 psi	5 hrs.		1		1, 20	5
W-8-M-87	8"	Cored concrete masonry; see Notes 2, 19, 26, 30, 43; No facings.	80 psi	12 min.		1		1, 20	⅓
W-8-M-88	8"	Cored concrete masonry; see Notes 2, 18, 26, 30, 43; No facings.	80 psi	12 min.		1		1, 20	⅓
W-8-M-89	8½"	Cored concrete masonry; see Notes 2, 19, 26, 34, 40; Facings: fire side only; see Note 38.	80 psi	2 hrs.		1		1, 20	2
W-8-M-90	8½"	Cored concrete masonry; see Notes 2, 18, 26, 34, 40; Facings: side 1; see Note 38.	80 psi	5 hrs.		1		1, 20	5
W-8-M-91	8½"	Cored concrete masonry; see Notes 2, 19, 26, 31, 40; Facings: fire side only; see Note 38.	80 psi	1 hr. 45 min.		1		1, 20	1¾
W-8-M-92	8½"	Cored concrete masonry; see Notes 2, 18, 26, 31, 40; Facings: one side; see Note 38.	80 psi	4 hrs.		1		1, 20	4
W-8-M-93	8½"	Cored concrete masonry; see Notes 2, 19, 26, 36, 41; Facings: fire side only; see Note 38.	80 psi	2 hrs.		1		1, 20	2
W-8-M-94	8½"	Cored concrete masonry; see Notes 2, 18, 26, 36, 41; Facings: fire side only; see Note 38.	80 psi	4 hrs.		1		1, 20	4
W-8-M-95	8½"	Cored concrete masonry; see Notes 2, 19, 26, 34, 41; Facings: fire side only; see Note 38.	80 psi	1 hr. 30 min.		1		1, 20	1½
W-8-M-96	8½"	Cored concrete masonry; see Notes 2, 18, 26, 34, 41; Facings: one side; see Note 38.	80 psi	3 hrs.				1, 20	3
W-8-M-97	8½"	Cored concrete masonry; see Notes 2, 19, 26, 29, 41; Facings: fire side only; see Note 38.	80 psi	1 hr. 30 min.		1		1, 20	1½
W-8-M-98	8½"	Cored concrete masonry; see Notes 2, 18, 26, 29, 41; Facings: one side; see Note 38.	80 psi	2 hrs. 30 min.		1		1, 20	2½
W-8-M-99	8½"	Cored concrete masonry; see Notes 3, 19, 23, 27, 41; No facings.	80 psi	1 hr. 15 min.		1		1, 20	1¼

(continued)

**TABLE 1.1.4—continued
MASONRY WALLS
8" TO LESS THAN 10" THICK**

ITEM CODE	THICKNESS	CONSTRUCTION DETAILS	PERFORMANCE		REFERENCE NUMBER			NOTES	REC. HOURS
			LOAD	TIME	PRE-BMS-92	BMS-92	POST-BMS-92		
W-8-M-100	8½"	Cored concrete masonry; see Notes 3, 18, 23, 27, 41; No facings.	80 psi	3 hrs. 30 min.		1		1, 20	3½
W-8-M-101	8½"	Cored concrete masonry; see Notes 3, 18, 26, 34, 41; Facings: 3¾" brick face; one side only; see Note 38.	80 psi	6 hrs.		1		1, 20	6
W-8-M-102	8½"	Cored concrete masonry; see Notes 2, 19, 26, 30, 43; Facings: fire side only; see Note 38.	80 psi	30 min.		1		1, 20	½
W-8-M-103	8½"	Cored concrete masonry; see Notes 2, 18, 26, 30, 43; Facings: one side only; see Note 38.	80 psi	12 min.		1		1, 20	⅓
W-8-M-104	9"	Cored concrete masonry; see Notes 2, 18, 26, 34, 40; Facings: both sides; see Note 38.	80 psi	6 hrs.		1		1, 20	6
W-8-M-105	9"	Cored concrete masonry; see Notes 2, 18, 26, 31, 40; Facings: both sides; see Note 38.	80 psi	5 hrs.		1		1, 20	5
W-8-M-106	9"	Cored concrete masonry; see Notes 2, 18, 26, 36, 41; Facings: both sides of wall; see Note 38.	80 psi	5 hrs.		1		1, 20	5
W-8-M-107	9"	Cored concrete masonry; see Notes 2, 18, 26, 34, 41; Facings: both sides; see Note 38.	80 psi	4 hrs.		1		1, 20	4
W-8-M-108	9"	Cored concrete masonry; see Notes 2, 18, 26, 29, 41; Facings: both sides; see Note 38.	80 psi	3 hrs. 30 min.		1		1, 20	3½
W-8-M-109	9"	Cored concrete masonry; see Notes 3, 19, 23, 27, 40; Facings: fire side only; see Note 38.	80 psi	1 hr. 45 min.		1		1, 20	1¾
W-8-M-110	9"	Cored concrete masonry; see Notes 3, 18, 23, 27, 41; Facings: one side only; see Note 38.	80 psi	4 hrs.		1		1, 20	4
W-8-M-111	9"	Cored concrete masonry; see Notes 3, 18, 26, 34, 41; 2¼" brick face on one side only; see Note 38.	80 psi	5 hrs.		1		1, 20	5
W-8-M-112	9"	Cored concrete masonry; see Notes 2, 18, 26, 30, 43; Facings: both sides; see Note 38.	80 psi	30 min.		1		1, 20	½
W-9-M-113	9½"	Cored concrete masonry; see Notes 3, 18, 23, 27, 41; Facings: both sides; see Note 38.	80 psi	5 hrs.		1		1, 20	5
W-8-M-114	8"		200 psi	5 hrs.			43	22	5

For SI: 1 inch = 25.4 mm, 1 pound per square inch = 0.00689 MPa.

Notes:

1. Tested at NBS under ASA Spec. No. 43-1934 (ASTM C19-53).
2. One unit in wall thickness.
3. Two units in wall thickness.
4. Two or three units in wall thickness.
5. Two cells in wall thickness.
6. Three or four cells in wall thickness.
7. Four or five cells in wall thickness.
8. Five or six cells in wall thickness.
9. Minimum percent of solid materials in units = 40%.
10. Minimum percent of solid materials in units = 43%.
11. Minimum percent of solid materials in units = 46%.
12. Minimum percent of solid materials in units = 48%.
13. Minimum percent of solid materials in units = 49%.
14. Minimum percent of solid materials in units = 45%.
15. Minimum percent of solid materials in units = 51%.
16. Minimum percent of solid materials in units = 53%.
17. Not less than 5/8 inch thickness of 1:3 sanded gypsum plaster.
18. Noncombustible or no members framed into wall.

(continued)

**TABLE 1.1.4—continued
MASONRY WALLS
8" TO LESS THAN 10" THICK**

19. Combustible members framed into wall.
20. Load: 80 psi for gross cross-sectional area of wall.
21. Portland cement-lime mortar.
22. Failure mode thermal.
23. British test.
24. Passed all criteria.
25. Failed by sudden collapse with no preceding signs of impending failure.
26. One cell in wall thickness.
27. Two cells in wall thickness.
28. Three cells in wall thickness.
29. Minimum percent of solid material in concrete units = 52.
30. Minimum percent of solid material in concrete units = 54.
31. Minimum percent of solid material in concrete units = 55.
32. Minimum percent of solid material in concrete units = 57.
33. Minimum percent of solid material in concrete units = 60.
34. Minimum percent of solid material in concrete units = 62.
35. Minimum percent of solid material in concrete units = 65.
36. Minimum percent of solid material in concrete units = 70.
37. Minimum percent of solid material in concrete units = 76.
38. Not less than $\frac{1}{2}$ inch of 1:3 sanded gypsum plaster.
39. Three units in wall thickness.
40. Concrete units made with expanded slag or pumice aggregates.
41. Concrete units made with expanded burned clay or shale, crushed limestone, air cooled slag or cinders.
42. Concrete units made with calcareous sand and gravel. Coarse aggregate, 60 percent or more calcite and dolomite.
43. Concrete units made with siliceous sand and gravel. Ninety percent or more quartz, chert and dolomite.
44. Load: 120 psi for gross cross-sectional area of wall.
45. Load: 160 psi for gross cross-sectional area of wall.

**FIGURE 1.1.5
MASONRY WALLS
10" TO LESS THAN 12" THICK**

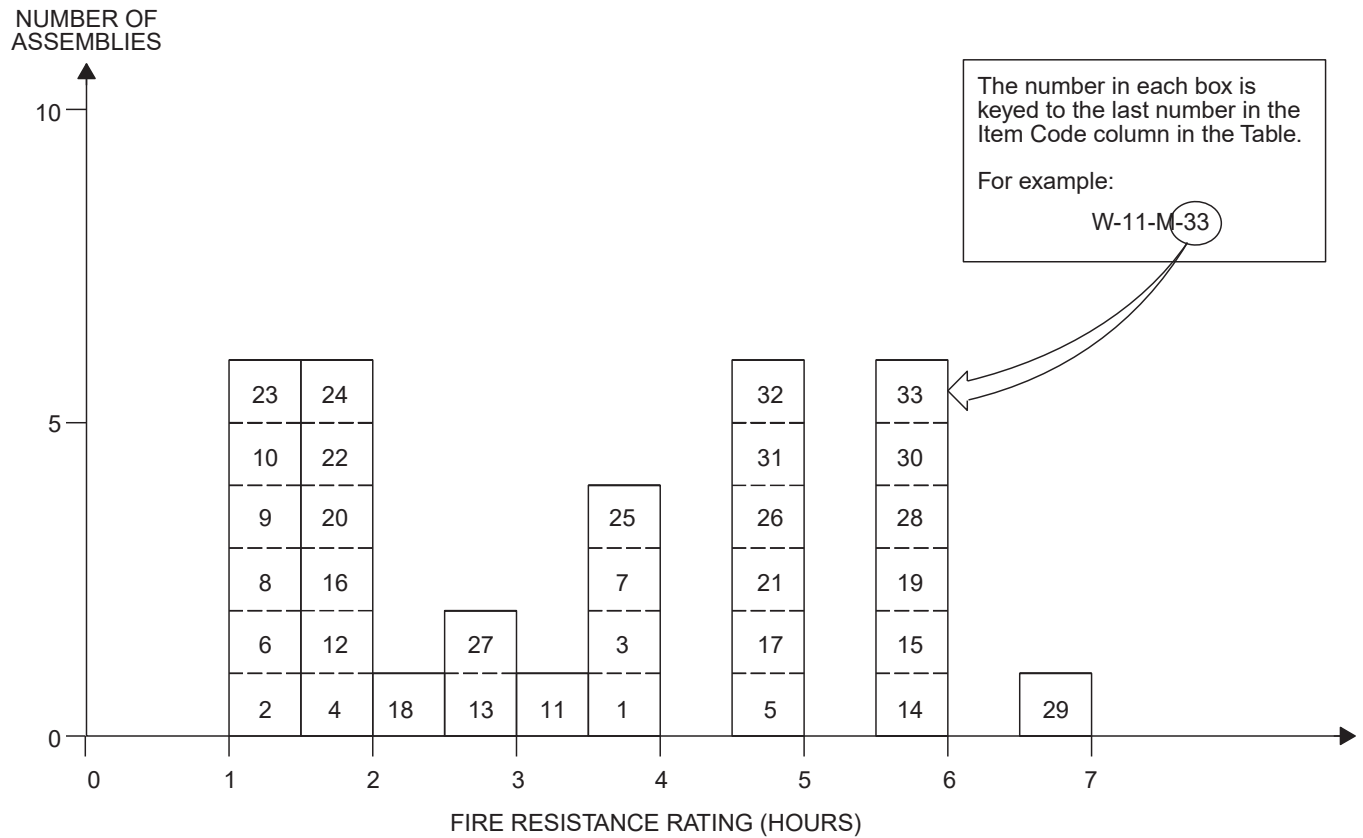

**TABLE 1.1.5
MASONRY WALLS
10" TO LESS THAN 12" THICK**

ITEM CODE	THICKNESS	CONSTRUCTION DETAILS	PERFORMANCE		REFERENCE NUMBER			NOTES	REC. HOURS
			LOAD	TIME	PRE-BMS-92	BMS-92	POST-BMS-92		
W-10-M-1	10"	Core: two 3 ³ / ₄ ", 40% solid clay or shale structural tiles with 2" air space between; Facings: 3/4" portland cement plaster on stucco on both sides.	80 psi	4 hrs.		1		1, 20	4
W-10-M-2	10"	Core: cored concrete masonry, 2" air cavity; see Notes 3, 19, 27, 34, 40; No facings.	80 psi	1 hr. 30 min.		1		1, 20	1½
W-10-M-3	10"	Cored concrete masonry; see Notes 3, 18, 27, 34, 40; No facings.	80 psi	4 hrs.		1		1, 20	4
W-10-M-4	10"	Cored concrete masonry; see Notes 2, 19, 26, 34, 40; No facings.	80 psi	2 hrs.		1		1, 20	2
W-10-M-5	10"	Cored concrete masonry; see Notes 2, 18, 26, 33, 40; No facings.	80 psi	5 hrs.		1		1, 20	5
W-10-M-6	10"	Cored concrete masonry; see Notes 2, 19, 26, 33, 41; No facings.	80 psi	1 hr. 30 min.		1		1, 20	1½
W-10-M-7	10"	Cored concrete masonry; see Notes 2, 18, 26, 33, 41; No facings.	80 psi	4 hrs.		1		1, 20	4
W-10-M-8	10"	Cored concrete masonry (cavity type 2" air space); see Notes 3, 19, 27, 34, 42; No facings.	80 psi	1 hr. 15 min.		1		1, 20	1¼

(continued)

**TABLE 1.1.5—continued
MASONRY WALLS
10" TO LESS THAN 12" THICK**

ITEM CODE	THICKNESS	CONSTRUCTION DETAILS	PERFORMANCE		REFERENCE NUMBER			NOTES	REC. HOURS
			LOAD	TIME	PRE-BMS-92	BMS-92	POST-BMS-92		
W-10-M-9	10"	Cored concrete masonry (cavity type 2" air space); see Notes 3, 18, 27, 34, 42; No facings.	80 psi	1 hr. 15 min.		1		1, 20	1 ¹ / ₄
W-10-M-10	10"	Cored concrete masonry (cavity type 2" air space); see Notes 3, 19, 27, 34, 41; No facings.	80 psi	1 hr. 15 min.		1		1, 20	1 ¹ / ₄
W-10-M-11	10"	Cored concrete masonry (cavity type 2" air space); see Notes 3, 18, 27, 34, 41; No facings.	80 psi	3 hrs. 30 min.		1		1, 20	3 ¹ / ₂
W-10-M-12	10"	9" thick concrete block (11 ³ / ₄ " × 9" × 4 ¹ / ₄ ") with two 2" thick voids included; ³ / ₈ " P.C. plaster ¹ / ₈ " neat gypsum.	N/A	1 hr. 53 min.			7	23, 44	1 ³ / ₄
W-10-M-13	10"	Holly clay tile block wall - 8 ¹ / ₂ " block with two 3" voids in each 8 ¹ / ₂ " section; ³ / ₄ " gypsum plaster - each face.	N/A	2 hrs. 42 min.			7	23, 25	2 ¹ / ₂
W-10-M-14	10"	Two layers 4 ¹ / ₄ " brick with 1 ¹ / ₂ " air space; No ties sand cement mortar. (Fletton brick - 1910 psi).	N/A	6 hrs.			7	23, 24	6
W-10-M-15	10"	Two layers 4 ¹ / ₄ " thick Fletton brick (1910 psi); 1 ¹ / ₂ " air space; Ties: 18" o.c. vertical; 3' o.c. horizontal.	N/A	6 hrs.			7	23, 24	6
W-10-M-16	10 ¹ / ₂ "	Cored concrete masonry; 2" air cavity; see Notes 3, 19, 27, 34, 40; Facings: fire side only; see Note 38.	80 psi	2 hrs.		1		1, 20	2
W-10-M-17	10 ¹ / ₂ "	Cored concrete masonry; see Notes 3, 18, 27, 34, 40; Facings: side 1 only; see Note 38.	80 psi	5 hrs.		1		1, 20	5
W-10-M-18	10 ¹ / ₂ "	Cored concrete masonry; see Notes 2, 19, 26, 33, 40; Facings: fire side only; see Note 38.	80 psi	2 hrs. 30 min.		1		1, 20	2 ¹ / ₂
W-10-M-19	10 ¹ / ₂ "	Cored concrete masonry; see Notes 2, 18, 26, 33, 40; Facings: one side; see Note 38.	80 psi	6 hrs.		1		1, 20	6
W-10-M-20	10 ¹ / ₂ "	Cored concrete masonry; see Notes 2, 19, 26, 33, 41; Facings: fire side of wall only; see Note 38.	80 psi	2 hrs.		1		1, 20	2
W-10-M-21	10 ¹ / ₂ "	Cored concrete masonry; see Notes 2, 18, 26, 33, 41; Facings: one side only; see Note 38.	80 psi	5 hrs.		1		1, 20	5
W-10-M-22	10 ¹ / ₂ "	Cored concrete masonry (cavity type 2" air space); see Notes 3, 19, 27, 34, 42; Facings: fire side only; see Note 38.	80 psi	1 hr. 45 min.		1		1, 20	1 ³ / ₄
W-10-M-23	10 ¹ / ₂ "	Cored concrete masonry (cavity type 2" air space); see Notes 3, 18, 27, 34, 42; Facings: one side only; see Note 38.	80 psi	1 hr. 15 min.		1		1, 20	1 ¹ / ₄
W-10-M-24	10 ¹ / ₂ "	Cored concrete masonry (cavity type 2" air space); see Notes 3, 19, 27, 34, 41; Facings: fire side only; see Note 38.	80 psi	2 hrs.		1		1, 20	2
W-10-M-25	10 ¹ / ₂ "	Cored concrete masonry (cavity type 2" air space); see Notes 3, 18, 27, 34, 41; Facings: one side only; see Note 38.	80 psi	4 hrs.		1		1, 20	4
W-10-M-26	10 ⁵ / ₈ "	Core: 8", 40% solid tile plus 2" furring tile; ⁵ / ₈ " sanded gypsum plaster between tile types; Facings: both sides ³ / ₄ " portland cement plaster or stucco.	80 psi	5 hrs.		1		1, 20	5

(continued)

**TABLE 1.1.5—continued
MASONRY WALLS
10" TO LESS THAN 12" THICK**

ITEM CODE	THICKNESS	CONSTRUCTION DETAILS	PERFORMANCE		REFERENCE NUMBER			NOTES	REC. HOURS
			LOAD	TIME	PRE-BMS-92	BMS-92	POST-BMS-92		
W-10-M-27	10 ⁵ / ₈ "	Core: 8", 40% solid tile plus 2" furring tile; ⁵ / ₈ " sanded gypsum plaster between tile types; Facings: one side ³ / ₄ " portland cement plaster or stucco.	80 psi	3 hrs. 30 min.		1		1, 20	3 ¹ / ₂
W-11-M-28	11"	Cored concrete masonry; see Notes 3, 18, 27, 34, 40; Facings: both sides; see Note 38.	80 psi	6 hrs.		1		1, 20	6
W-11-M-29	11"	Cored concrete masonry; see Notes 2, 18, 26, 33, 40; Facings: both sides; see Note 38.	80 psi	7 hrs.		1		1, 20	7
W-11-M-30	11"	Cored concrete masonry; see Notes 2, 18, 26, 33, 41; Facings: both sides of wall; see Note 38.	80 psi	6 hrs.		1		1, 20	6
W-11-M-31	11"	Cored concrete masonry (cavity type 2" air space); see Notes 3, 18, 27, 34, 42; Facings: both sides; see Note 38.	80 psi	5 hrs.		1		1, 20	5
W-11-M-32	11"	Cored concrete masonry (cavity type 2" air space); see Notes 3, 18, 27, 34, 41; Facings: both sides; see Note 38.	80 psi	5 hrs.		1		1, 20	5
W-11-M-33	11"	Two layers brick (4 ¹ / ₂ " Fletton, 2,428 psi) 2" air space; galvanized ties; 18" o.c. - horizontal; 3' o.c. - vertical.	3 tons/ft.	6 hrs.			7	23, 24	6

For SI: 1 inch = 25.4 mm, 1 pound per square inch = 0.00689 MPa.

Notes:

1. Tested at NBS - ASA Spec. No. A2-1934.
2. One unit in wall thickness.
3. Two units in wall thickness.
4. Two or three units in wall thickness.
5. Two cells in wall thickness.
6. Three or four cells in wall thickness.
7. Four or five cells in wall thickness.
8. Five or six cells in wall thickness.
9. Minimum percent of solid materials in units = 40%.
10. Minimum percent of solid materials in units = 43%.
11. Minimum percent of solid materials in units = 46%.
12. Minimum percent of solid materials in units = 48%.
13. Minimum percent of solid materials in units = 49%.
14. Minimum percent of solid materials in units = 45%.
15. Minimum percent of solid materials in units = 51%.
16. Minimum percent of solid materials in units = 53%.
17. Not less than ⁵/₈ inch thickness of 1:3 sanded gypsum plaster.
18. Noncombustible or no members framed into wall.
19. Combustible members framed into wall.
20. Load: 80 psi for gross cross sectional area of wall.
21. Portland cement-lime mortar.
22. Failure mode—thermal.
23. British test.
24. Passed all criteria.
25. Failed by sudden collapse with no preceding signs of impending failure.
26. One cell in wall thickness.
27. Two cells in wall thickness.
28. Three cells in wall thickness.
29. Minimum percent of solid material in concrete units = 52%.
30. Minimum percent of solid material in concrete units = 54%.
31. Minimum percent of solid material in concrete units = 55%.
32. Minimum percent of solid material in concrete units = 57%.
33. Minimum percent of solid material in concrete units = 60%.
34. Minimum percent of solid material in concrete units = 62%.
35. Minimum percent of solid material in concrete units = 65%.

(continued)

**TABLE 1.1.5—continued
MASONRY WALLS
10" TO LESS THAN 12" THICK**

36. Minimum percent of solid material in concrete units = 70%.
37. Minimum percent of solid material in concrete units = 76%.
38. Not less than $\frac{1}{2}$ inch of 1:3 sanded gypsum plaster.
39. Three units in wall thickness.
40. Concrete units made with expanded slag or pumice aggregates.
41. Concrete units made with expanded burned clay or shale, crushed limestone, air cooled slag or cinders.
42. Concrete units made with calcareous sand and gravel. Coarse aggregate, 60 percent or more calcite and dolomite.

**FIGURE 1.1.6
MASONRY WALLS
12" TO LESS THAN 14" THICK**

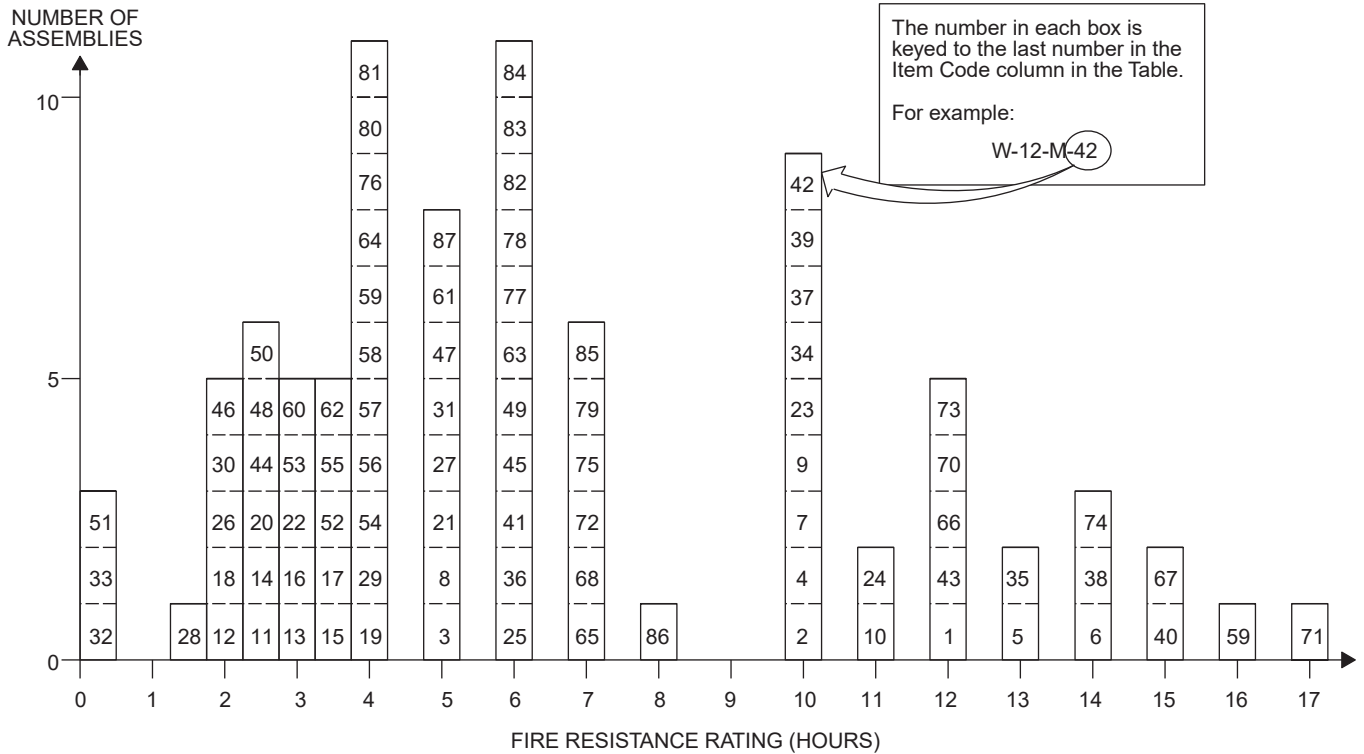

**TABLE 1.1.6
MASONRY WALLS
12" TO LESS THAN 14" THICK**

ITEM CODE	THICKNESS	CONSTRUCTION DETAILS	PERFORMANCE		REFERENCE NUMBER			NOTES	REC. HOURS
			LOAD	TIME	PRE-BMS-92	BMS-92	POST-BMS-92		
W-12-M-1	12"	Core: solid clay or shale brick; No facings.	N/A	12 hrs.		1		1	12
W-12-M-2	12"	Core: solid clay or shale brick; No facings.	160 psi	10 hrs.		1		1, 44	10
W-12-M-3	12"	Core: hollow rolok of clay or shale; No facings.	160 psi	5 hrs.		1		1, 44	5
W-12-M-4	12"	Core: hollow rolok bak of clay or shale; No facings.	160 psi	10 hrs.		1		1, 44	10
W-12-M-5	12"	Core: concrete brick; No facings.	160 psi	13 hrs.		1		1, 44	13
W-12-M-6	12"	Core: sand-lime brick; No facings.	N/A	14 hrs.		1		1	14
W-12-M-7	12"	Core: sand-lime brick; No facings.	160 psi	10 hrs.		1		1, 44	10
W-12-M-8	12"	Cored clay or shale brick; Units in wall thickness: 1; Cells in wall thickness: 2; Minimum % solids: 70; No facings.	120 psi	5 hrs.		1		1, 45	5
W-12-M-9	12"	Cored clay or shale brick; Units in wall thickness: 3; Cells in wall thickness: 3; Minimum % solids: 87; No facings.	160 psi	10 hrs.		1		1, 44	10
W-12-M-10	12"	Cored clay or shale brick; Units in wall thickness: 3; Cells in wall thickness: 3; Minimum % solids: 87; No facings.	N/A	11 hrs.		1		1	11

(continued)

**TABLE 1.1.6—continued
MASONRY WALLS
12" TO LESS THAN 14" THICK**

ITEM CODE	THICKNESS	CONSTRUCTION DETAILS	PERFORMANCE		REFERENCE NUMBER			NOTES	REC. HOURS
			LOAD	TIME	PRE-BMS-92	BMS-92	POST-BMS-92		
W-12-M-11	12"	Core: clay or shale structural tile; see Notes 2, 6, 9, 18; No facings.	80 psi	2 hrs.		1		1, 20	2½
W-12-M-12	12"	Core: clay or shale structural tile; see Notes 2, 4, 9, 19; No facings.	80 psi	2 hrs.		1		1, 20	2
W-12-M-13	12"	Core: clay or shale structural tile; see Notes 2, 6, 14, 19; No facings.	80 psi	3 hrs.		1		1, 20	3
W-12-M-14	12"	Core: clay or shale structural tile; see Notes 2, 6, 14, 18; No facings.	80 psi	2 hrs. 30 min.		1		1, 20	2½
W-12-M-15	12"	Core: clay or shale structural tile; see Notes 2, 4, 13, 18; No facings.	80 psi	3 hrs. 30 min.		1		1, 20	3½
W-12-M-16	12"	Core: clay or shale structural tile; see Notes 2, 4, 13, 19; No facings.	80 psi	3 hrs.		1		1, 20	3
W-12-M-17	12"	Core: clay or shale structural tile; see Notes 3, 6, 9, 18; No facings.	80 psi	3 hrs. 30 min.		1		1, 20	3½
W-12-M-18	12"	Core: clay or shale structural tile; see Notes 3, 6, 9, 19; No facings.	80 psi	2 hrs.		1		1, 20	2
W-12-M-19	12"	Core: clay or shale structural tile; see Notes 3, 6, 14, 18; No facings.	80 psi	4 hrs.		1		1, 20	4
W-12-M-20	12"	Core: clay or shale structural tile; see Notes 3, 6, 14, 19; No facings.	80 psi	2 hrs. 30 min.		1		1, 20	2½
W-12-M-21	12"	Core: clay or shale structural tile; see Notes 3, 6, 16, 18; No facings.	80 psi	5 hrs.		1		1, 20	5
W-12-M-22	12"	Core: clay or shale structural tile; see Notes 3, 6, 16, 19; No facings.	80 psi	3 hrs.		1		1, 20	3
W-12-M-23	12"	Core: 8", 70% solid clay or shale structural tile; 4" brick facings on one side.	80 psi	10 hrs.		1		1, 20	10
W-12-M-24	12"	Core: 8", 70% solid clay or shale structural tile; 4" brick facings on one side.	N/A	11 hrs.		1		1	11
W-12-M-25	12"	Core: 8", 40% solid clay or shale structural tile; 4" brick facings on one side.	80 psi	6 hrs.		1		1, 20	6
W-12-M-26	12"	Cored concrete masonry; see Notes 1, 9, 15, 16, 20; No facings.	80 psi	2 hrs.		1		1, 20	2
W-12-M-27	12"	Cored concrete masonry; see Notes 2, 18, 26, 34, 41; No facings.	80 psi	5 hrs.		1		1, 20	5
W-12-M-28	12"	Cored concrete masonry; see Notes 2, 19, 26, 31, 41; No facings.	80 psi	1 hr. 30 min.		1		1, 20	1½
W-12-M-29	12"	Cored concrete masonry; see Notes 2, 18, 26, 31, 41; No facings.	80 psi	4 hrs.		1		1, 20	4
W-12-M-30	12"	Cored concrete masonry; see Notes 3, 19, 27, 31, 43; No facings.	80 psi	2 hrs.		1		1, 20	2
W-12-M-31	12"	Cored concrete masonry; see Notes 3, 18, 27, 31, 43; No facings.	80 psi	5 hrs.		1		1, 20	5
W-12-M-32	12"	Cored concrete masonry; see Notes 2, 19, 26, 32, 43; No facings.	80 psi	25 min.		1		1, 20	⅓
W-12-M-33	12"	Cored concrete masonry; see Notes 2, 18, 26, 32, 43; No facings.	80 psi	25 min.		1		1, 20	⅓

(continued)

**TABLE 1.1.6—continued
MASONRY WALLS
12" TO LESS THAN 14" THICK**

ITEM CODE	THICKNESS	CONSTRUCTION DETAILS	PERFORMANCE		REFERENCE NUMBER			NOTES	REC. HOURS
			LOAD	TIME	PRE-BMS-92	BMS-92	POST-BMS-92		
W-12-M-34	12½"	Core: solid clay or shale brick; ½" of 1:3 sanded gypsum plaster facings on one side.	160 psi	10 hrs.		1		1, 44	10
W-12-M-35	12½"	Core: solid clay or shale brick; ½" of 1:3 sanded gypsum plaster facings on one side.	N/A	13 hrs.		1		1	13
W-12-M-36	12½"	Core: hollow rolok of clay or shale; ½" of 1:3 sanded gypsum plaster facings on one side.	160 psi	6 hrs.		1		1, 44	6
W-12-M-37	12½"	Core: hollow rolok bak of clay or shale; ½" of 1:3 sanded gypsum plaster facings on one side.	160 psi	10 hrs.		1		1, 44	10
W-12-M-38	12½"	Core: concrete; ½" of 1:3 sanded gypsum plaster facings on one side.	160 psi	14 hrs.		1		1, 44	14
W-12-M-39	12½"	Core: sand-lime brick; ½" of 1:3 sanded gypsum plaster facings on one side.	160 psi	10 hrs.		1		1, 44	10
W-12-M-40	12½"	Core: sand-lime brick; ½" of 1:3 sanded gypsum plaster facings on one side.	N/A	15 hrs.		1		1	15
W-12-M-41	12½"	Cored clay or shale brick; Units in wall thickness: 1; Cells in wall thickness: 2; Minimum % solids: 70; ½" of 1:3 sanded gypsum plaster facings on one side.	120 psi	6 hrs.		1		1, 45	6
W-12-M-42	12½"	Cored clay or shale brick; Units in wall thickness: 3; Cells in wall thickness: 3; Minimum % solids: 87; ½" of 1:3 sanded gypsum plaster facings on one side.	160 psi	10 hrs.		1		1, 44	10
W-12-M-43	12½"	Cored clay or shale brick; Units in wall thickness: 3; Cells in wall thickness: 3; Minimum % solids: 87; ½" of 1:3 sanded gypsum plaster facings on one side.	N/A	12 hrs.		1		1	12
W-12-M-44	12½"	Cored concrete masonry; see Notes 2, 19, 26, 34, 41; Facings: fire side only; see Note 38.	80 psi	2 hrs. 30 min.		1		1, 20	2½
W-12-M-45	12½"	Cored concrete masonry; see Notes 2, 18, 26, 34, 39, 41; Facings: one side only; see Note 38.	80 psi	6 hrs.		1		1, 20	6
W-12-M-46	12½"	Cored concrete masonry; see Notes 2, 19, 26, 31, 41; Facings: fire side only; see Note 38.	80 psi	2 hrs.		1		1, 20	2
W-12-M-47	12½"	Cored concrete masonry; see Notes 2, 18, 26, 31, 41; Facings: one side of wall only; see Note 38.	80 psi	5 hrs.		1		1, 20	5
W-12-M-48	12½"	Cored concrete masonry; see Notes 3, 19, 27, 31, 43; Facings: fire side only; see Note 38.	80 psi	2 hrs. 30 min.		1		1, 20	2½
W-12-M-49	12½"	Cored concrete masonry; see Notes 3, 18, 27, 31, 43; Facings: one side only; see Note 38.	80 psi	6 hrs.		1		1, 20	6
W-12-M-50	12½"	Cored concrete masonry; see Notes 2, 19, 26, 32, 43; Facings: fire side only; see Note 38.	80 psi	2 hrs. 30 min.		1		1, 20	2½

(continued)

**TABLE 1.1.6—continued
MASONRY WALLS
12" TO LESS THAN 14" THICK**

ITEM CODE	THICKNESS	CONSTRUCTION DETAILS	PERFORMANCE		REFERENCE NUMBER			NOTES	REC. HOURS
			LOAD	TIME	PRE-BMS-92	BMS-92	POST-BMS-92		
W-12-M-51	12 ¹ / ₂ "	Cored concrete masonry; see Notes 2, 18, 26, 32, 43; Facings: one side only; see Note 38.	80 psi	25 min.		1		1, 20	1/3
W-12-M-52	12 ⁵ / ₈ "	Clay or shale structural tile; see Notes 2, 6, 9, 18; Facings: side 1, see Note 17; side 2, none.	80 psi	3 hrs. 30 min.		1		1, 20	3 ¹ / ₂
W-12-M-53	12 ⁵ / ₈ "	Clay or shale structural tile; see Notes 2, 6, 9, 19; Facings: fire side only; see Note 17.	80 psi	3 hrs.		1		1, 20	3
W-12-M-54	12 ⁵ / ₈ "	Clay or shale structural tile; see Notes 2, 6, 14, 19; Facings: side 1, see Note 17; side 2, none.	80 psi	4 hrs.		1		1, 20	4
W-12-M-55	12 ⁵ / ₈ "	Clay or shale structural tile; see Notes 2, 6, 14, 18; Facings: exposed side only; see Note 17.	80 psi	3 hrs. 30 min.		1		1, 20	3 ¹ / ₂
W-12-M-56	12 ⁵ / ₈ "	Clay or shale structural tile; see Notes 2, 4, 13, 18; Facings: side 1, see Note 17; side 2, none.	80 psi	4 hrs.		1		1, 20	4
W-12-M-57	12 ⁵ / ₈ "	Clay or shale structural tile; see Notes 1, 4, 13, 19; Facings: fire side only; see Note 17.	80 psi	4 hrs.		1		1, 20	4
W-12-M-58	12 ⁵ / ₈ "	Clay or shale structural tile; see Notes 3, 6, 9, 18; Facings: side 1, see Note 17; side 2, none.	80 psi	4 hrs.		1		1, 20	4
W-12-M-59	12 ⁵ / ₈ "	Clay or shale structural tile; see Notes 3, 6, 9, 19; Facings: fire side only; see Note 17.	80 psi	3 hrs.		1		1, 20	3
W-12-M-60	12 ⁵ / ₈ "	Clay or shale structural tile; see Notes 3, 6, 14, 18; Facings: side 1, see Note 17; side 2, none.	80 psi	5 hrs.		1		1, 20	5
W-12-M-61	12 ⁵ / ₈ "	Clay or shale structural tile; see Notes 3, 6, 14, 19; Facings: fire side only; see Note 17.	80 psi	3 hrs. 30 min.		1		1, 20	3 ¹ / ₂
W-12-M-62	12 ⁵ / ₈ "	Clay or shale structural tile; see Notes 3, 6, 16, 18; Facings: side 1, see Note 17; side 2, none.	80 psi	6 hrs.		1		1, 20	6
W-12-M-63	12 ⁵ / ₈ "	Clay or shale structural tile; see Notes 3, 6, 16, 19; Facings: fire side only; see Note 17.	80 psi	4 hrs.		1		1, 20	4
W-12-M-64	12 ⁵ / ₈ "	Core: 8", 40% solid clay or shale structural tile; Facings: 4" brick plus 5/8" of 1:3 sanded gypsum plaster on one side.	80 psi	7 hrs.		1		1, 20	7
W-13-M-65	13"	Core: solid clay or shale brick; 1/2" of 1:3 sanded gypsum plaster facings on both sides.	160 psi	12 hrs.		1		1, 44	12
W-13-M-66	13"	Core: solid clay or shale brick; 1/2" of 1:3 sanded gypsum plaster facings on both sides.	N/A	15 hrs.		1		1, 20	15
W-13-M-67	13"	Core: solid clay or shale brick; 1/2" of 1:3 sanded gypsum plaster facings on both sides.	N/A	15 hrs.		1		1	15
W-13-M-68	13"	Core: hollow rolok of clay or shale; 1/2" of 1:3 sanded gypsum plaster facings on both sides.	80 psi	7 hrs.		1		1, 20	7
W-13-M-69	13"	Core: concrete brick; 1/2" of 1:3 sanded gypsum plaster facings on both sides.	160 psi	16 hrs.		1		1, 44	16

(continued)

**TABLE 1.1.6—continued
MASONRY WALLS
12" TO LESS THAN 14" THICK**

ITEM CODE	THICKNESS	CONSTRUCTION DETAILS	PERFORMANCE		REFERENCE NUMBER			NOTES	REC. HOURS
			LOAD	TIME	PRE-BMS-92	BMS-92	POST-BMS-92		
W-13-M-70	13"	Core: sand-lime brick; 1/2" of 1:3 sanded gypsum plaster facings on both sides.	160 psi	12 hrs.		1		1, 44	12
W-13-M-71	13"	Core: sand-lime brick; 1/2" of 1:3 sanded gypsum plaster facings on both sides.	N/A	17 hrs.		1		1	17
W-13-M-72	13"	Cored clay or shale brick; Units in wall thickness: 1; Cells in wall thickness: 2; Minimum % solids: 70; 1/2" of 1:3 sanded gypsum plaster facings on both sides.	120 psi	7 hrs.		1		1, 45	7
W-13-M-73	13"	Cored clay or shale brick; Units in wall thickness: 3; Cells in wall thickness: 3; Minimum % solids: 87; 1/2" of 1:3 sanded gypsum plaster facings on both sides.	160 psi	12 hrs.		1		1, 44	12
W-13-M-74	13"	Cored clay or shale brick; Units in wall thickness: 3; Cells in wall thickness: 2; Minimum % solids: 87; 1/2" of 1:3 sanded gypsum plaster facings on both sides.	N/A	14 hrs.		1		1	14
W-13-M-75	13"	Cored concrete masonry; see Notes 18, 23, 28, 39, 41; No facings.	80 psi	7 hrs.		1		1, 20	7
W-13-M-76	13"	Cored concrete masonry; see Notes 19, 23, 28, 39, 41; No facings.	80 psi	4 hrs.		1		1, 20	4
W-13-M-77	13"	Cored concrete masonry; see Notes 3, 18, 27, 31, 43; Facings: both sides; see Note 38.	80 psi	6 hrs.		1		1, 20	6
W-13-M-78	13"	Cored concrete masonry; see Notes 2, 18, 26, 31, 41; Facings: both sides; see Note 38.	80 psi	6 hrs.		1		1, 20	6
W-13-M-79	13"	Cored concrete masonry; see Notes 2, 18, 26, 34, 41; Facings: both sides of wall; see Note 38.	80 psi	7 hrs.		1		1, 20	7
W-13-M-80	13 1/4"	Core: clay or shale structural tile; see Notes 2, 6, 9, 18; Facings: both sides; see Note 17.	80 psi	4 hrs.		1		1, 20	4
W-13-M-82	13 1/4"	Core: clay or shale structural tile; see Notes 2, 4, 13, 18; Facings: both sides; see Note 17.	80 psi	6 hrs.		1		1, 20	6
W-13-M-83	13 1/4"	Core: clay or shale structural tile; see Notes 3, 6, 9, 18; Facings: both sides; see Note 17.	80 psi	6 hrs.		1		1, 20	6
W-13-M-84	13 1/4"	Core: clay or shale structural tile; see Notes 3, 6, 14, 18; Facings: both sides; see Note 17.	80 psi	6 hrs.		1		1, 20	6
W-13-M-85	13 1/4"	Core: clay or shale structural tile; see Notes 3, 6, 16, 18; Facings: both sides; see Note 17.	80 psi	7 hrs.		1		1, 20	7

(continued)

RESOURCE A

**TABLE 1.1.6—continued
MASONRY WALLS
12" TO LESS THAN 14" THICK**

ITEM CODE	THICKNESS	CONSTRUCTION DETAILS	PERFORMANCE		REFERENCE NUMBER			NOTES	REC. HOURS
			LOAD	TIME	PRE-BMS-92	BMS-92	POST-BMS-92		
W-13-M-86	13½"	Cored concrete masonry; see Notes 18, 23, 28, 39, 41; Facings: one side only; see Note 38.	80 psi	8 hrs.		1		1, 20	8
W-13-M-87	13½"	Cored concrete masonry; see Notes 19, 23, 28, 39, 41; Facings: fire side only; see Note 38.	80 psi	5 hrs.		1		1, 20	5

For SI: 1 inch = 25.4 mm, 1 pound per square inch = 0.00689 MPa.

Notes:

1. Tested at NBS - ASA Spec. No. A2-1934.
2. One unit in wall thickness.
3. Two units in wall thickness.
4. Two or three units in wall thickness.
5. Two cells in wall thickness.
6. Three or four cells in wall thickness.
7. Four or five cells in wall thickness.
8. Five or six cells in wall thickness.
9. Minimum percent of solid materials in units = 40%.
10. Minimum percent of solid materials in units = 43%.
11. Minimum percent of solid materials in units = 46%.
12. Minimum percent of solid materials in units = 48%.
13. Minimum percent of solid materials in units = 49%.
14. Minimum percent of solid materials in units = 45%.
15. Minimum percent of solid materials in units = 51%.
16. Minimum percent of solid materials in units = 53%.
17. Not less than 5/8 inch thickness of 1:3 sanded gypsum plaster.
18. Noncombustible or no members framed into wall.
19. Combustible members framed into wall.
20. Load: 80 psi for gross area.
21. Portland cement-lime mortar.
22. Failure mode-thermal.
23. British test.
24. Passed all criteria.
25. Failed by sudden collapse with no preceding signs of impending failure.
26. One cell in wall thickness.
27. Two cells in wall thickness.
28. Three cells in wall thickness.
29. Minimum percent of solid material in concrete units = 52%.
30. Minimum percent of solid material in concrete units = 54%.
31. Minimum percent of solid material in concrete units = 55%.
32. Minimum percent of solid material in concrete units = 57%.
33. Minimum percent of solid material in concrete units = 60%.
34. Minimum percent of solid material in concrete units = 62%.
35. Minimum percent of solid material in concrete units = 65%.
36. Minimum percent of solid material in concrete units = 70%.
37. Minimum percent of solid material in concrete units = 76%.
38. Not less than 1/2 inch of 1:3 sanded gypsum plaster.
39. Three units in wall thickness.
40. Concrete units made with expanded slag or pumice aggregates.
41. Concrete units made with expanded burned clay or shale, crushed limestone, air cooled slag or cinders.
42. Concrete units made with calcareous sand and gravel. Coarse aggregate, 60 percent or more calcite and dolomite.
43. Concrete units made with siliceous sand and gravel. Ninety percent or more quartz, chert or flint.
44. Load: 160 psi of gross wall cross sectional area.
45. Load: 120 psi of gross wall cross sectional area.

**FIGURE 1.1.7
MASONRY WALLS
14" OR MORE THICK**

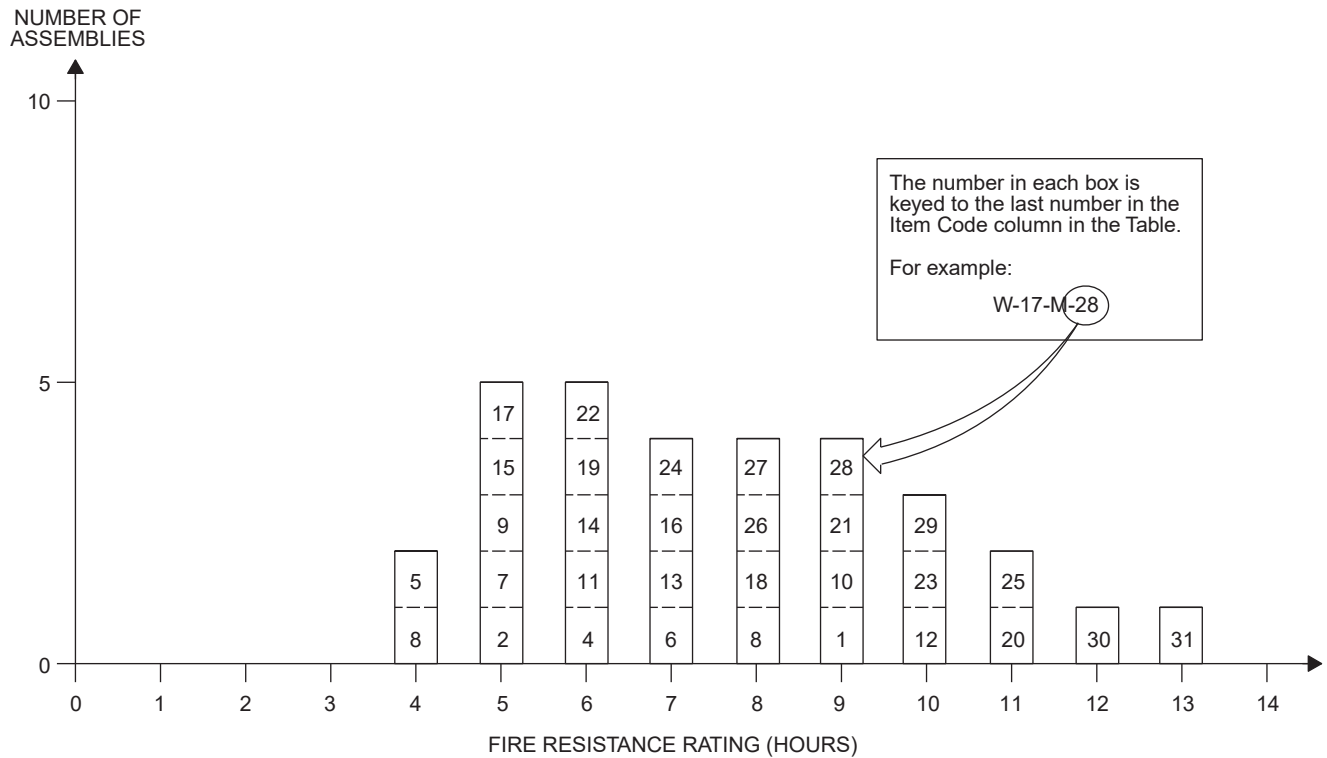

**TABLE 1.1.7
MASONRY WALLS
14" OR MORE THICK**

ITEM CODE	THICKNESS	CONSTRUCTION DETAILS	PERFORMANCE		REFERENCE NUMBER			NOTES	REC. HOURS
			LOAD	TIME	PRE-BMS-92	BMS-92	POST-BMS-92		
W-14-M-1	14"	Core: cored masonry; see Notes 18, 28, 33, 39, 41; Facings: both sides; see Note 38.	80 psi	9 hrs.		1		1, 20	9
W-16-M-2	16"	Core: clay or shale structural tile; see Notes 4, 7, 9, 19; No facings.	80 psi	5 hrs.		1		1, 20	5
W-16-M-3	16"	Core: clay or shale structural tile; see Notes 4, 7, 9, 19; No facings.	80 psi	4 hrs.		1		1, 20	4
W-16-M-4	16"	Core: clay or shale structural tile; see Notes 4, 7, 10, 18; No facings.	80 psi	6 hrs.		1		1, 20	6
W-16-M-5	16"	Core: clay or shale structural tile; see Notes 4, 7, 10, 19; No facings.	80 psi	4 hrs.		1		1, 20	4
W-16-M-6	16"	Core: clay or shale structural tile; see Notes 4, 7, 11, 18; No facings.	80 psi	7 hrs.		1		1, 20	7
W-16-M-7	16"	Core: clay or shale structural tile; see Notes 4, 7, 11, 19; No facings.	80 psi	5 hrs.		1		1, 20	5
W-16-M-8	16"	Core: clay or shale structural tile; see Notes 4, 8, 13, 18; No facings.	80 psi	8 hrs.		1		1, 20	8
W-16-M-9	16"	Core: clay or shale structural tile; see Notes 4, 8, 13, 19; No facings.	80 psi	5 hrs.		1		1, 20	5

(continued)

**TABLE 1.1.7—continued
MASONRY WALLS
14" OR MORE THICK**

ITEM CODE	THICKNESS	CONSTRUCTION DETAILS	PERFORMANCE		REFERENCE NUMBER			NOTES	REC. HOURS
			LOAD	TIME	PRE-BMS-92	BMS-92	POST-BMS-92		
W-16-M-10	16"	Core: clay or shale structural tile; see Notes 4, 8, 15, 18; No facings.	80 psi	9 hrs.		1		1, 20	9
W-16-M-11	16"	Core: clay or shale structural tile; see Notes 3, 7, 14, 18; No facings.	80 psi	6 hrs.		1		1, 20	6
W-16-M-12	16"	Core: clay or shale structural tile; see Notes 4, 8, 16, 18; No facings.	80 psi	10 hrs.		1		1, 20	10
W-16-M-13	16"	Core: clay or shale structural tile; see Notes 4, 6, 16, 19; No facings.	80 psi	7 hrs.		1		1, 20	7
W-16-M-14	16 ⁵ / ₈ "	Core: clay or shale structural tile; see Notes 4, 7, 9, 18; Facings: side 1, see Note 17; side 2, none.	80 psi	6 hrs.		1		1, 20	6
W-16-M-15	16 ⁵ / ₈ "	Core: clay or shale structural tile; see Notes 4, 7, 9, 19; Facings: fire side only; see Note 17.	80 psi	5 hrs.		1		1, 20	5
W-16-M-16	16 ⁵ / ₈ "	Core: clay or shale structural tile; see Notes 4, 7, 10, 18; Facings: side 1, see Note 17; side 2, none.	80 psi	7 hrs.		1		1, 20	7
W-16-M-17	16 ⁵ / ₈ "	Core: clay or shale structural tile; see Notes 4, 7, 10, 19; Facings: fire side only; see Note 17.	80 psi	5 hrs.		1		1, 20	5
W-16-M-18	16 ⁵ / ₈ "	Core: clay or shale structural tile; see Notes 4, 7, 11, 18; Facings: side 1, see Note 17; side 2, none.	80 psi	5 hrs.		1		1, 20	5
W-16-M-19	16 ⁵ / ₈ "	Core: clay or shale structural tile; see Notes 4, 7, 11, 19; Facings: fire side only; see Note 17.	80 psi	6 hrs.		1		1, 20	6
W-16-M-20	16 ⁵ / ₈ "	Core: clay or shale structural tile; see Notes 4, 8, 13, 18; Facings: sides 1 and 2; see Note 17.	80 psi	11 hrs.		1		1, 20	11
W-16-M-21	16 ⁵ / ₈ "	Core: clay or shale structural tile; see Notes 4, 8, 13 18; Facings: side 1, see Note 17; side 2, none.	80 psi	9 hrs.		1		1, 20	9
W-16-M-22	16 ⁵ / ₈ "	Core: clay or shale structural tile; see Notes 4, 8, 13, 19; Facings: fire side only; see Note 17.	80 psi	6 hrs.		1		1, 20	6
W-16-M-23	16 ⁵ / ₈ "	Core: clay or shale structural tile; see Notes 4, 8, 15, 18; Facings: side 1, see Note 17; side 2, none.	80 psi	10 hrs.		1		1, 20	10
W-16-M-24	16 ⁵ / ₈ "	Core: clay or shale structural tile; see Notes 4, 8, 15, 19; Facings: fire side only; see Note 17.	80 psi	7 hrs.		1		1, 20	7
W-16-M-25	16 ⁵ / ₈ "	Core: clay or shale structural tile; see Notes 4, 6, 16, 18; Facings: side 1, see Note 17; side 2, none.	80 psi	11 hrs.		1		1, 20	11
W-16-M-26	16 ⁵ / ₈ "	Core: clay or shale structural tile; see Notes 4, 6, 16, 19; Facings: fire side only; see Note 17.	80 psi	8 hrs.		1		1, 20	8

(continued)

**TABLE 1.1.7—continued
MASONRY WALLS
14" OR MORE THICK**

ITEM CODE	THICKNESS	CONSTRUCTION DETAILS	PERFORMANCE		REFERENCE NUMBER			NOTES	REC. HOURS
			LOAD	TIME	PRE-BMS-92	BMS-92	POST-BMS-92		
W-17-M-27	17 ¹ / ₄ "	Core: clay or shale structural tile; see Notes 4, 7, 9, 18; Facings: sides 1 and 2; see Note 17.	80 psi	8 hrs.		1		1, 20	8
W-17-M-28	17 ¹ / ₄ "	Core: clay or shale structural tile; see Notes 4, 7, 10, 18; Facings: sides 1 and 2; see Note 17.	80 psi	9 hrs.		1		1, 20	9
W-17-M-29	17 ¹ / ₄ "	Core: clay or shale structural tile; see Notes 4, 7, 11, 18; Facings: sides 1 and 2; see Note 17.	80 psi	10 hrs.		1		1, 20	10
W-17-M-30	17 ¹ / ₄ "	Core: clay or shale structural tile; see Notes 4, 8, 15, 18; Facings: sides 1 and 2; see Note 17.	80 psi	12 hrs.		1		1, 20	12
W-17-M-31	17 ¹ / ₄ "	Core: clay or shale structural tile; see Notes 4, 6, 16, 18; Facings: sides 1 and 2; see Note 17.	80 psi	13 hrs.		1		1, 20	13

For SI: 1 inch = 25.4 mm, 1 pound per square inch = 0.00689 MPa.

Notes:

1. Tested at NBS - ASA Spec. No. A2-1934.
2. One unit in wall thickness.
3. Two units in wall thickness.
4. Two or three units in wall thickness.
5. Two cells in wall thickness.
6. Three or four cells in wall thickness.
7. Four or five cells in wall thickness.
8. Five or six cells in wall thickness.
9. Minimum percent of solid materials in units = 40%.
10. Minimum percent of solid materials in units = 43%.
11. Minimum percent of solid materials in units = 46%.
12. Minimum percent of solid materials in units = 48%.
13. Minimum percent of solid materials in units = 49%.
14. Minimum percent of solid materials in units = 45%.
15. Minimum percent of solid materials in units = 51%.
16. Minimum percent of solid materials in units = 53%.
17. Not less than 5/8 inch thickness of 1:3 sanded gypsum plaster.
18. Noncombustible or no members framed into wall.
19. Combustible members framed into wall.
20. Load: 80 psi for gross area.
21. Portland cement-lime mortar.
22. Failure mode—thermal.
23. British test.
24. Passed all criteria.
25. Failed by sudden collapse with no preceding signs of impending failure.
26. One cell in wall thickness.
27. Two cells in wall thickness.
28. Three cells in wall thickness.
29. Minimum percent of solid material in concrete units = 52%.
30. Minimum percent of solid material in concrete units = 54%.
31. Minimum percent of solid material in concrete units = 55%.
32. Minimum percent of solid material in concrete units = 57%.
33. Minimum percent of solid material in concrete units = 60%.
34. Minimum percent of solid material in concrete units = 62%.
35. Minimum percent of solid material in concrete units = 65%.
36. Minimum percent of solid material in concrete units = 70%.
37. Minimum percent of solid material in concrete units = 76%.
38. Not less than 1/2 inch of 1:3 sanded gypsum plaster.
39. Three units in wall thickness.
40. Concrete units made with expanded slag or pumice aggregates.
41. Concrete units made with expanded burned clay or shale, crushed limestone, air cooled slag or cinders.
42. Concrete units made with calcareous sand and gravel. Coarse aggregate, 60 percent or more calcite and dolomite.
43. Concrete units made with siliceous sand and gravel. Ninety percent or more quartz, chert or flint.

**FIGURE 1.2.1
METAL FRAME WALLS
0" TO LESS THAN 4" THICK**

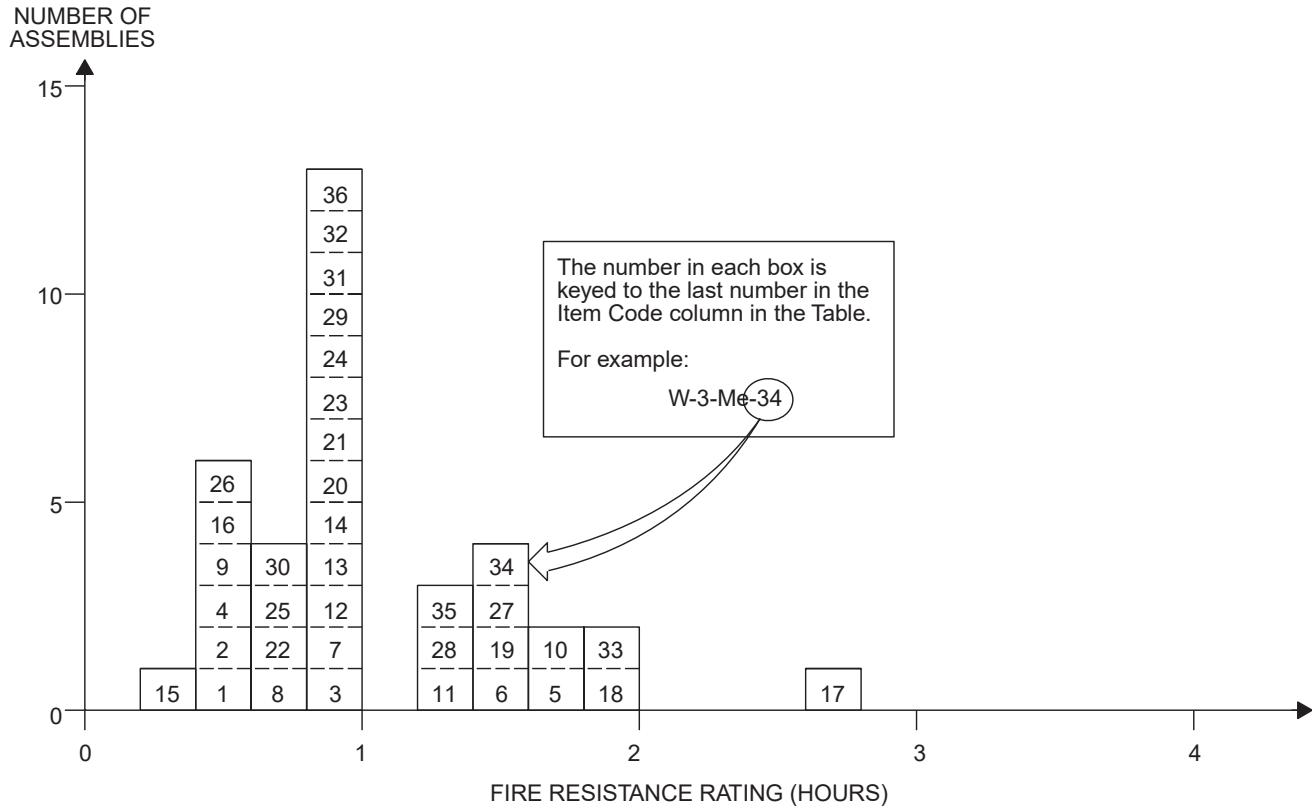

**TABLE 1.2.1
METAL FRAME WALLS
0" TO LESS THAN 4" THICK**

ITEM CODE	THICKNESS	CONSTRUCTION DETAILS	PERFORMANCE		REFERENCE NUMBER			NOTES	REC. HOURS
			LOAD	TIME	PRE-BMS-92	BMS-92	POST-BMS-92		
W-3-Me-1	3"	Core: steel channels having three rows of 4" x 1/8" staggered slots in web; core filled with heat expanded vermiculite weighing 1.5 lbs./ft. ² of wall area; Facings: sides 1 and 2, 18 gage steel, spot welded to core.	N/A	25 min.		1			1/3
W-3-Me-2	3"	Core: steel channels having three rows of 4" x 1/8" staggered slots in web; core filled with heat expanded vermiculite weighing 2 lbs./ft. ² of wall area; Facings: sides 1 and 2, 18 gage steel, spot welded to core.	N/A	30 min.		1			1/2
W-3-Me-3	2 1/2"	Solid partition: 3/8" tension rods (vertical) 3' o.c. with metal lath; Scratch coat: cement/sand/lime plaster; Float coats: cement/sand/lime plaster; Finish coats: neat gypsum plaster.	N/A	1 hr.			7	1	1
W-2-Me-4	2"	Solid wall: steel channel per Note 1; 2" thickness of 1:2; 1:3 portland cement on metal lath.	N/A	30 min.		1			1/2

(continued)

**TABLE 1.2.1—continued
METAL FRAME WALLS
0" TO LESS THAN 4" THICK**

ITEM CODE	THICKNESS	CONSTRUCTION DETAILS	PERFORMANCE		REFERENCE NUMBER			NOTES	REC. HOURS
			LOAD	TIME	PRE-BMS-92	BMS-92	POST-BMS-92		
W-2-Me-5	2"	Solid wall: steel channel per Note 1; 2" thickness of neat gypsum plaster on metal lath.	N/A	1 hr. 45 min.		1			1 ³ / ₄
W-2-Me-6	2"	Solid wall: steel channel per Note 1; 2" thickness of 1:1 ¹ / ₂ ; 1:1 ¹ / ₂ gypsum plaster on metal lath.	N/A	1 hr. 30 min.		1			1 ¹ / ₂
W-2-Me-7	2"	Solid wall: steel channel per Note 2; 2" thickness of 1:1; 1:1 gypsum plaster on metal lath.	N/A	1 hr.		1			1
W-2-Me-8	2"	Solid wall: steel channel per Note 1; 2" thickness of 1:2; 1:2 gypsum plaster on metal lath.	N/A	45 min.		1			³ / ₄
W-2-Me-9	2 ¹ / ₄ "	Solid wall: steel channel per Note 2; 2 ¹ / ₄ " thickness of 1:2; 1:3 portland cement on metal lath.	N/A	30 min.		1			¹ / ₂
W-2-Me-10	2 ¹ / ₄ "	Solid wall: steel channel per Note 2; 2 ¹ / ₄ " thickness of neat gypsum plaster on metal lath.	N/A	2 hrs.		1			2
W-2-Me-11	2 ¹ / ₄ "	Solid wall: steel channel per Note 2; 2 ¹ / ₄ " thickness of 1:1 ¹ / ₂ ; 1:1 ¹ / ₂ gypsum plaster on metal lath.	N/A	1 hr. 45 min.		1			1 ³ / ₄
W-2-Me-12	2 ¹ / ₄ "	Solid wall: steel channel per Note 2; 2 ¹ / ₄ " thickness of 1:1; 1:1 gypsum plaster on metal lath.	N/A	1 hr. 15 min.		1			1 ¹ / ₄
W-2-Me-13	2 ¹ / ₄ "	Solid wall: steel channel per Note 2; 2 ¹ / ₄ " thickness of 1:2; 1:2 gypsum plaster on metal lath.	N/A	1 hr.		1			1
W-2-Me-14	2 ¹ / ₂ "	Solid wall: steel channel per Note 1; 2 ¹ / ₂ " thickness of 4.5:1:7; 4.5:1:7 portland cement, sawdust and sand sprayed on wire mesh; see Note 3.	N/A	1 hr.		1			1
W-2-Me-15	2 ¹ / ₂ "	Solid wall: steel channel per Note 2; 2 ¹ / ₂ " thickness of 1:4; 1:4 portland cement sprayed on wire mesh; see Note 3.	N/A	20 min.		1			¹ / ₃
W-2-Me-16	2 ¹ / ₂ "	Solid wall: steel channel per Note 2; 2 ¹ / ₂ " thickness of 1:2; 1:3 portland cement on metal lath.	N/A	30 min.		1			¹ / ₂
W-2-Me-17	2 ¹ / ₂ "	Solid wall: steel channel per Note 2; 2 ¹ / ₂ " thickness of neat gypsum plaster on metal lath.	N/A	2 hrs. 30 min.		1			2 ¹ / ₂
W-2-Me-18	2 ¹ / ₂ "	Solid wall: steel channel per Note 2; 2 ¹ / ₂ " thickness of 1:1 ¹ / ₂ ; 1:1 ¹ / ₂ gypsum plaster on metal lath.	N/A	2 hrs.		1			2
W-2-Me-19	2 ¹ / ₂ "	Solid wall: steel channel per Note 2; 2 ¹ / ₂ " thickness of 1:1; 1:1 gypsum plaster on metal lath.	N/A	1 hr. 30 min.		1			1 ¹ / ₂

(continued)

**TABLE 1.2.1—continued
METAL FRAME WALLS
0" TO LESS THAN 4" THICK**

ITEM CODE	THICKNESS	CONSTRUCTION DETAILS	PERFORMANCE		REFERENCE NUMBER			NOTES	REC. HOURS
			LOAD	TIME	PRE-BMS-92	BMS-92	POST-BMS-92		
W-2-Me-20	2 1/2"	Solid wall: steel channel per Note 2; 2 1/2" thickness of 1:2; 1:2 gypsum plaster on metal lath.	N/A	1 hr.		1			1
W-2-Me-21	2 1/2"	Solid wall: steel channel per Note 2; 2 1/2" thickness of 1:2; 1:3 gypsum plaster on metal lath.	N/A	1 hr.		1			1
W-3-Me-22	3"	Core: steel channel per Note 2; 1:2; 1:2 gypsum plaster on 3/4" soft asbestos lath; plaster thickness 2".	N/A	45 min.		1			3/4
W-3-Me-23	3 1/2"	Solid wall: steel channel per Note 2; 2 1/2" thickness of 1:2; 1:2 gypsum plaster on 3/4" asbestos lath.	N/A	1 hr.		1			1
W-3-Me-24	3 1/2"	Solid wall: steel channel per Note 2; lath over and 1:2 1/2; 1:2 1/2 gypsum plaster on 1" magnesium oxysulfate wood fiberboard; plaster thickness 2 1/2".	N/A	1 hr.		1			1
W-3-Me-25	3 1/2"	Core: steel studs; see Note 4; Facings: 3/4" thickness of 1:1/30; 2; 1:1/30; 3 portland cement and asbestos fiber plaster.	N/A	45 min.		1			3/4
W-3-Me-26	3 1/2"	Core: steel studs; see Note 4; Facings: both sides 3/4" thickness of 1:2; 1:3 portland cement.	N/A	30 min.		1			1/2
W-3-Me-27	3 1/2"	Core: steel studs; see Note 4; Facings: both sides 3/4" thickness of neat gypsum plaster.	N/A	1 hr. 30 min.		1			1 1/2
W-3-Me-28	3 1/2"	Core: steel studs; see Note 4; Facings: both sides 3/4" thickness of 1:1/2; 1:1/2 gypsum plaster.	N/A	1 hr. 15 min.		1			1 1/4
W-3-Me-29	3 1/2"	Core: steel studs; see Note 4; Facings: both sides 3/4" thickness of 1:2; 1:2 gypsum plaster.	N/A	1 hr.		1			1
W-3-Me-30	3 1/2"	Core: steel studs; see Note 4; Facings: both sides 3/4" thickness of 1:2; 1:3 gypsum plaster.	N/A	45 min.		1			3/4
W-3-Me-31	3 3/4"	Core: steel studs; see Note 4; Facings: both sides 7/8" thickness of 1:1/30; 2; 1:1/30; 3 portland cement and asbestos fiber plaster.	N/A	1 hr.		1			1
W-3-Me-32	3 3/4"	Core: steel studs; see Note 4; Facings: both sides 7/8" thickness of 1:2; 1:3 portland cement.	N/A	45 min.		1			3/4
W-3-Me-33	3 3/4"	Core: steel studs; see Note 4; Facings: both sides 7/8" thickness of neat gypsum plaster.	N/A	2 hrs.		1			2
W-3-Me-34	3 3/4"	Core: steel studs; see Note 4; Facings: both sides 7/8" thickness of 1:1/2; 1:1/2 gypsum plaster.	N/A	1 hr. 30 min.		1			1 1/2

(continued)

**TABLE 1.2.1—continued
METAL FRAME WALLS
0" TO LESS THAN 4" THICK**

ITEM CODE	THICKNESS	CONSTRUCTION DETAILS	PERFORMANCE		REFERENCE NUMBER			NOTES	REC. HOURS
			LOAD	TIME	PRE-BMS-92	BMS-92	POST-BMS-92		
W-3-Me-35	3 ³ / ₄ "	Core: steel studs; see Note 4; Facings: both sides ⁷ / ₈ " thickness of 1:2; 1:2 gypsum plaster.	N/A	1 hr. 15 min.		1			1 ¹ / ₄
W-3-Me-36	3 ³ / ₄ "	Core: steel; see Note 4; Facings: ⁷ / ₈ " thickness of 1:2; 1:3 gypsum plaster on both sides.	N/A	1 hr.		1			1

For SI: 1 inch = 25.4 mm.

Notes:

1. Failure mode—local temperature rise—back face.
2. Three-fourths inch or 1 inch channel framing—hot-rolled or strip-steel channels.
3. Reinforcement is 4-inch square mesh of No. 6 wire welded at intersections (no channels).
4. Ratings are for any usual type of nonload-bearing metal framing providing 2 inches (or more) air space.

General Note:

The construction details of the wall assemblies are as complete as the source documentation will permit. Data on the method of attachment of facings and the gauge of steel studs was provided when known. The cross-sectional area of the steel stud can be computed, thereby permitting a reasoned estimate of actual loading conditions. For load-bearing assemblies, the maximum allowable stress for the steel studs has been provided in the table "Notes." More often, it is the thermal properties of the facing materials, rather than the specific gauge of the steel, that will determine the degree of fire resistance. This is particularly true for nonbearing wall assemblies.

**FIGURE 1.2.2
METAL FRAME WALLS
4" TO LESS THAN 6" THICK**

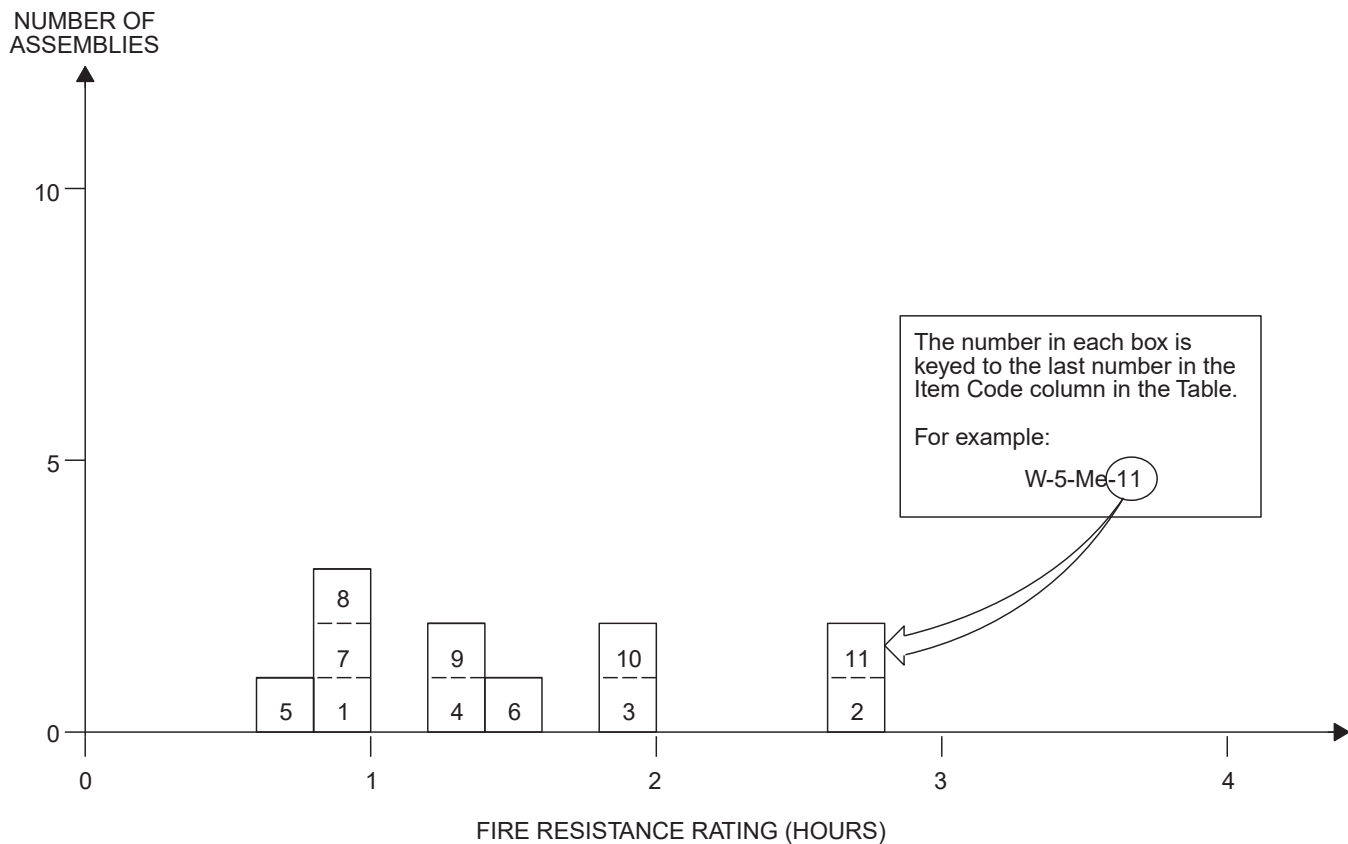

**TABLE 1.2.2
METAL FRAME WALLS
4" TO LESS THAN 6" THICK**

ITEM CODE	THICKNESS	CONSTRUCTION DETAILS	PERFORMANCE		REFERENCE NUMBER			NOTES	REC. HOURS
			LOAD	TIME	PRE-BMS-92	BMS-92	POST-BMS-92		
W-5-Me-1	5 1/2"	3" cavity with 16 ga. channel studs (3 1/2" o.c.) of 1/2" x 1/2" channel and 3" spacer; Metal lath on ribs with plaster (three coats) 3/4" over face of lath; Plaster (each side): scratch coat, cement/lime/sand with hair; float coat, cement/lime/sand; finish coat, neat gypsum.	N/A	1 hr. 11 min.			7	1	1
W-4-Me-2	4"	Core: steel studs; see Note 2; Facings: both sides 1" thickness of neat gypsum plaster.	N/A	2 hrs. 30 min.		1			2 1/2
W-4-Me-3	4"	Core: steel studs; see Note 2; Facings: both sides 1" thickness of 1:1/2; 1:1/2 gypsum plaster.	N/A	2 hrs.		1			2
W-4-Me-4	4"	Core: steel; see Note 2; Facings: both sides 1" thickness of 1:2; 1:3 gypsum plaster.	N/A	1 hr. 15 min.		1			1 1/4
W-4-Me-5	4 1/2"	Core: lightweight steel studs 3" in depth; Facings: both sides 3/4" thick sanded gypsum plaster, 1:2 scratch coat, 1:3 brown coat applied on metal lath.	See Note 4	45 min.		1		5	3/4

(continued)

**TABLE 1.2.2—continued
METAL FRAME WALLS
4" TO LESS THAN 6" THICK**

ITEM CODE	THICKNESS	CONSTRUCTION DETAILS	PERFORMANCE		REFERENCE NUMBER			NOTES	REC. HOURS
			LOAD	TIME	PRE-BMS-92	BMS-92	POST-BMS-92		
W-4-Me-6	4 ¹ / ₂ "	Core: lightweight steel studs 3" in depth; Facings: both sides 3/4" thick neat gypsum plaster on metal lath.	See Note 4	1 hr. 30 min.		1		5	1 ¹ / ₂
W-4-Me-7	4 ¹ / ₂ "	Core: lightweight steel studs 3" in depth; Facings: both sides 3/4" thick sanded gypsum plaster, 1:2 scratch and brown coats applied on metal lath.	See Note 4	1 hr.		1		5	1
W-4-Me-8	4 ³ / ₄ "	Core: lightweight steel studs 3" in depth; Facings: both sides 7/8" thick sanded gypsum plaster, 1:2 scratch coat, 1:3 brown coat, applied on metal lath.	See Note 4	1 hr.		1		5	1
W-4-Me-9	4 ³ / ₄ "	Core: lightweight steel studs 3" in depth; Facings: both sides 7/8" thick sanded gypsum plaster, 1:2 scratch and 1:3 brown coats applied on metal lath.	See Note 4	1 hr. 15 min.		1		5	1 ¹ / ₄
W-5-Me-10	5"	Core: lightweight steel studs 3" in depth; Facings: both sides 1" thick neat gypsum plaster on metal lath.	See Note 4	2 hrs.		1		5	2
W-5-Me-11	5"	Core: lightweight steel studs 3" in depth; Facings: both sides 1" thick neat gypsum plaster on metal lath.	See Note 4	2 hrs. 30 min.		1		5, 6	2 ¹ / ₂

For SI: 1 inch = 25.4 mm, 1 pound per square inch = 0.00689 MPa.

Notes:

1. Failure mode—local back face temperature rise.
2. Ratings are for any usual type of nonbearing metal framing providing a minimum 2 inches air space.
3. Facing materials secured to lightweight steel studs not less than 3 inches deep.
4. Rating based on loading to develop a maximum stress of 7270 psi for net area of each stud.
5. Spacing of steel studs must be sufficient to develop adequate rigidity in the metal-lath or gypsum-plaster base.
6. As per Note 4 but load/stud not to exceed 5120 psi.

General Note:

The construction details of the wall assemblies are as complete as the source documentation will permit. Data on the method of attachment of facings and the gauge of steel studs was provided when known. The cross sectional area of the steel stud can be computed, thereby permitting a reasoned estimate of actual loading conditions. For load-bearing assemblies, the maximum allowable stress for the steel studs has been provided in the table "Notes." More often, it is the thermal properties of the facing materials, rather than the specific gauge of the steel, that will determine the degree of fire resistance. This is particularly true for nonbearing wall assemblies.

**TABLE 1.2.3
METAL FRAME WALLS
6" TO LESS THAN 8" THICK**

ITEM CODE	THICKNESS	CONSTRUCTION DETAILS	PERFORMANCE		REFERENCE NUMBER			NOTES	REC HOURS
			LOAD	TIME	PRE-BMS-92	BMS-92	POST-BMS-92		
W-6-Me-1	6 ⁵ / ₈ "	On one side of 1" magnesium oxysulfate wood fiberboard sheathing attached to steel studs (see Notes 1 and 2), 1" air space, 3 ³ / ₄ " brick secured with metal ties to steel frame every fifth course; Inside facing of 7 ⁷ / ₈ " 1:2 sanded gypsum plaster on metal lath secured directly to studs; Plaster side exposed to fire.	See Note 2	1 hr. 45 min.		1		1	1 ³ / ₄
W-6-Me-2	6 ⁵ / ₈ "	On one side of 1" magnesium oxysulfate wood fiberboard sheathing attached to steel studs (see Notes 1 and 2), 1" air space, 3 ³ / ₄ " brick secured with metal ties to steel frame every fifth course; Inside facing of 7 ⁷ / ₈ " 1:2 sanded gypsum plaster on metal lath secured directly to studs; Brick face exposed to fire.	See Note 2	4 hrs.		1		1	4
W-6-Me-3	6 ⁵ / ₈ "	On one side of 1" magnesium oxysulfate wood fiberboard sheathing attached to steel studs (see Notes 1 and 2), 1" air space, 3 ³ / ₄ " brick secured with metal ties to steel frame every fifth course; Inside facing of 7 ⁷ / ₈ " vermiculite plaster on metal lath secured directly to studs; Plaster side exposed to fire.	See Note 2	2 hrs.		1		1	2

For SI: 1 inch = 25.4 mm, 1 pound per square inch = 0.00689 MPa.

Notes:

1. Lightweight steel studs (minimum 3 inches deep) used. Stud spacing dependent on loading, but in each case, spacing is to be such that adequate rigidity is provided to the metal lath plaster base.
2. Load is such that stress developed in studs is not greater than 5120 psi calculated from net stud area.

General Note:

The construction details of the wall assemblies are as complete as the source documentation will permit. Data on the method of attachment of facings and the gauge of steel studs was provided when known. The cross sectional area of the steel stud can be computed, thereby permitting a reasoned estimate of actual loading conditions. For load-bearing assemblies, the maximum allowable stress for the steel studs has been provided in the table "Notes." More often, it is the thermal properties of the facing materials, rather than the specific gauge of the steel, that will determine the degree of fire resistance. This is particularly true for nonbearing wall assemblies.

**TABLE 1.2.4
METAL FRAME WALLS
8" TO LESS THAN 10" THICK**

ITEM CODE	THICKNESS	CONSTRUCTION DETAILS	PERFORMANCE		REFERENCE NUMBER			NOTES	REC. HOURS
			LOAD	TIME	PRE-BMS-92	BMS-92	POST-BMS-92		
W-9-Me-1	9 ¹ / ₁₆ "	On one side of 1/2" wood fiberboard sheathing next to studs, 3/4" air space formed with 3/4" x 1 5/8" wood strips placed over the fiberboard and secured to the studs, paper backed wire lath nailed to strips 3 3/4" brick veneer held in place by filling a 3/4" space between the brick and paper backed lath with mortar; Inside facing of 3/4" neat gypsum plaster on metal lath attached to 5/16" plywood strips secured to edges of steel studs; Rated as combustible because of the sheathing; See Notes 1 and 2; Plaster exposed.	See Note 2	1 hr. 45 min.		1		1	1 3/4
W-9-Me-2	9 ¹ / ₁₆ "	Same as above with brick exposed.	See Note 2	4 hrs.		1		1	4
W-8-Me-3	8 1/2"	On one side of paper backed wire lath attached to studs and 3 3/4" brick veneer held in place by filling a 1" space between the brick and lath with mortar; Inside facing of 1" paper-enclosed mineral wool blanket weighing 0.6 lb./ft. ² attached to studs, metal lath or paper backed wire lath laid over the blanket and attached to the studs, 3/4" sanded gypsum plaster 1:2 for the scratch coat and 1:3 for the brown coat; See Notes 1 and 2; Plaster face exposed.	See Note 2	4 hrs.		1		1	4
W-8-Me-4	8 1/2"	Same as above with brick exposed.	See Note 2	5 hrs.		1		1	5

For SI: 1 inch = 25.4 mm, 1 pound per square inch = 0.00689 MPa.

Notes:

1. Lightweight steel studs ≥ 3 inches in depth. Stud spacing dependent on loading, but in any case, the spacing is to be such that adequate rigidity is provided to the metal-lath plaster base.
2. Load is such that stress developed in studs is ≤ 5120 psi calculated from the net area of the stud.

General Note:

The construction details of the wall assemblies are as complete as the source documentation will permit. Data on the method of attachment of facings and the gauge of steel studs was provided when known. The cross sectional area of the steel stud can be computed, thereby permitting a reasoned estimate of actual loading conditions. For load-bearing assemblies, the maximum allowable stress for the steel studs has been provided in the table "Notes." More often, it is the thermal properties of the facing materials, rather than the specific gauge of the steel, that will determine the degree of fire resistance. This is particularly true for nonbearing wall assemblies.

RESOURCE A

**TABLE 1.3.1
WOOD FRAME WALLS
0" TO LESS THAN 4" THICK**

ITEM CODE	THICKNESS	CONSTRUCTION DETAILS	PERFORMANCE		REFERENCE NUMBER			NOTES	REC. HOURS
			LOAD	TIME	PRE-BMS-92	BMS-92	POST-BMS-92		
W-3-W-1	3 ³ / ₄ "	Solid wall: 2 ¹ / ₄ " wood-wool slab core; 3 ³ / ₄ " gypsum plaster each side.	N/A	2 hrs.			7	1, 6	2
W-3-W-2	3 ⁷ / ₈ "	2 × 4 stud wall; 3 ¹ / ₁₆ " thick cement asbestos board on both sides of wall.	360 psi net area	10 min.		1		2-5	1/6
W-3-W-3	3 ⁷ / ₈ "	Same as W-3-W-2 but stud cavities filled with 1 lb./ft. ² mineral wool batts.	360 psi net area	40 min.		1		2-5	2/3

For SI: 1 inch = 25.4 mm, 1 pound per square inch = 0.00689 MPa.

Notes:

1. Achieved "Grade C" fire resistance (British).
2. Nominal 2 × 4 wood studs of No. 1 common or better lumber set edgewise, 2 × 4 plates at top and bottom and blocking at mid height of wall.
3. All horizontal joints in facing material backed by 2 × 4 blocking in wall.
4. Load: 360 psi of net stud cross sectional area.
5. Facings secured with 6d casing nails. Nail holes predrilled and 0.02 inch to 0.03 inch smaller than nail diameter.
6. The wood-wool core is a pressed excelsior slab which possesses insulating properties similar to cellulosic insulation.

**FIGURE 1.3.2
WOOD FRAME WALLS
4" TO LESS THAN 6" THICK**

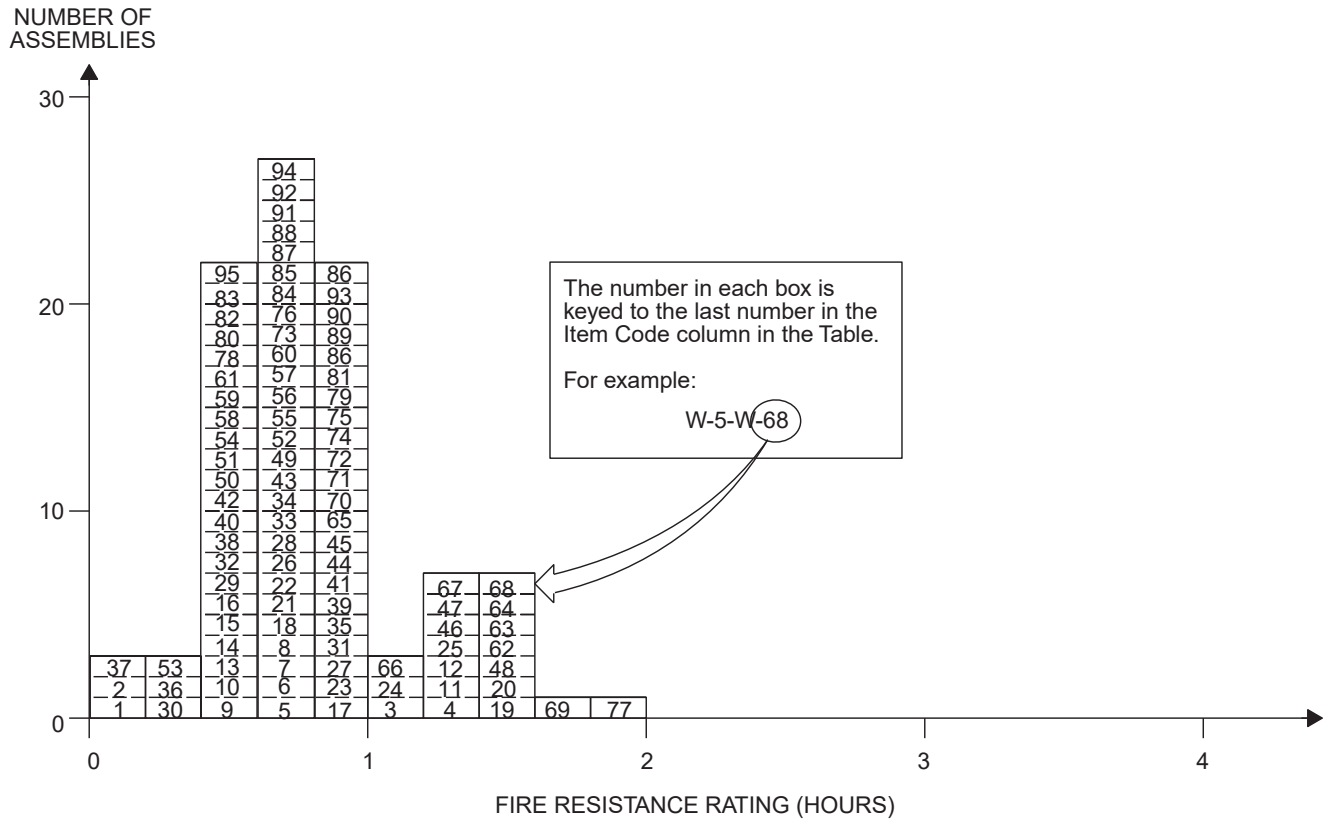

**TABLE 1.3.2
WOOD FRAME WALLS
4" TO LESS THAN 6" THICK**

ITEM CODE	THICKNESS	CONSTRUCTION DETAILS	PERFORMANCE		REFERENCE NUMBER			NOTES	REC. HOURS
			LOAD	TIME	PRE-BMS-92	BMS-92	POST-BMS-92		
W-4-W-1	4"	2" × 4" stud wall; 3/16" CAB; no insulation; Design A.	35 min.	10 min.			4	1-10	1/6
W-4-W-2	4 1/8"	2" × 4" stud wall; 3/16" CAB; no insulation; Design A.	38 min.	9 min.			4	1-10	1/6
W-4-W-3	4 3/4"	2" × 4" stud wall; 3/16" CAB and 3/8" gypsum board face (both sides); Design B.	62 min.	64 min.			4	1-10	1
W-5-W-4	5"	2" × 4" stud wall; 3/16" CAB and 1/2" gypsum board (both sides); Design B.	79 min.	Greater than 90 min.			4	1-10	1
W-4-W-5	4 3/4"	2" × 4" stud wall; 3/16" CAB and 3/8" gypsum board (both sides); Design B.	45 min.	45 min.			4	1-12	—
W-5-W-6	5"	2" × 4" stud wall; 3/16" CAB and 1/2" gypsum board face (both sides); Design B.	45 min.	45 min.			4	1-10, 12, 13	—
W-4-W-7	4"	2" × 4" stud wall; 3/16" CAB face; 3 1/2" mineral wool insulation; Design C.	40 min.	42 min.			4	1-10	2/3
W-4-W-8	4"	2" × 4" stud wall; 3/16" CAB face; 3 1/2" mineral wool insulation; Design C.	46 min.	46 min.			4	1-10, 43	2/3
W-4-W-9	4"	2" × 4" stud wall; 3/16" CAB face; 3 1/2" mineral wool insulation; Design C.	30 min.	30 min.			4	1-10, 12, 14	—

(continued)

**TABLE 1.3.2—continued
WOOD FRAME WALLS
4" TO LESS THAN 6" THICK**

ITEM CODE	THICKNESS	CONSTRUCTION DETAILS	PERFORMANCE		REFERENCE NUMBER			NOTES	REC. HOURS
			LOAD	TIME	PRE-BMS-92	BMS-92	POST-BMS-92		
W-4-W-10	4 ¹ / ₈ "	2" × 4" stud wall; 3/16" CAB face; 3 ¹ / ₂ " mineral wool insulation; Design C.	—	30 min.			4	1-8, 12, 14	—
W-4-W-11	4 ³ / ₄ "	2" × 4" stud wall; 3/16" CAB face; 3/8" gypsum strips over studs; 5 ¹ / ₂ " mineral wool insulation; Design D.	79 min.	79 min.			4	1-10	1
W-4-W-12	4 ³ / ₄ "	2" × 4" stud wall; 3/16" CAB face; 3/8" gypsum strips at stud edges; 7 ¹ / ₂ " mineral wool insulation; Design D.	82 min.	82 min.			4	1-10	1
W-4-W-13	4 ³ / ₄ "	2" × 4" stud wall; 3/16" CAB face; 3/8" gypsum board strips over studs; 5 ¹ / ₂ " mineral wool insulation; Design D.	30 min.	30 min.			4	1-12	—
W-4-W-14	4 ³ / ₄ "	2" × 4" stud wall; 3/16" CAB face; 3/8" gypsum board strips over studs; 7" mineral wool insulation; Design D.	30 min.	30 min.			4	1-12	—
W-5-W-15	5 ¹ / ₂ "	2" × 4" stud wall; Exposed face: CAB shingles over 1" × 6"; Unexposed face: 1/8" CAB sheet; 7/16" fiberboard (wood); Design E.	34 min.	—			4	1-10	1/2
W-5-W-16	5 ¹ / ₂ "	2" × 4" stud wall; Exposed face: 1/8" CAB sheet; 7/16" fiberboard; Unexposed face: CAB shingles over 1" × 6"; Design E.	32 min.	33 min.			4	1-10	1/2
W-5-W-17	5 ¹ / ₂ "	2" × 4" stud wall; Exposed face: CAB shingles over 1" × 6"; Unexposed face: 1/8" CAB sheet; gypsum at stud edges; 3 ¹ / ₂ " mineral wool insulation; Design F.	51 min.	—			4	1-10	3/4
W-5-W-18	5 ¹ / ₂ "	2" × 4" stud wall; Exposed face: 1/8" CAB sheet; gypsum board at stud edges; Unexposed face: CAB shingles over 1" × 6"; 3 ¹ / ₂ " mineral wool insulation; Design F.	42 min.	—			4	1-10	2/3
W-5-W-19	5 ⁵ / ₈ "	2" × 4" stud wall; Exposed face: CAB shingles over 1" × 6"; Unexposed face: 1/8" CAB sheet; gypsum board at stud edges; 5 ¹ / ₂ " mineral wool insulation; Design G.	74 min.	85 min.			4	1-10	1
W-5-W-20	5 ⁵ / ₈ "	2" × 4" stud wall; Exposed face: 1/8" CAB sheet; gypsum board at 3/16" stud edges; 7/16" fiberboard; Unexposed face: CAB shingles over 1" × 6"; 5 ¹ / ₂ " mineral wool insulation; Design G.	79 min.	85 min.			4	1-10	1 ¹ / ₄
W-5-W-21	5 ⁵ / ₈ "	2" × 4" stud wall; Exposed face: CAB shingles 1" × 6" sheathing; Unexposed face: CAB sheet; gypsum board at stud edges; 5 ¹ / ₂ " mineral wool insulation; Design G.	38 min.	38 min.			4	1-10, 12, 14	—
W-5-W-22	5 ⁵ / ₈ "	2" × 4" stud wall; Exposed face: CAB sheet; gypsum board at stud edges; Unexposed face: CAB shingles 1" × 6" sheathing; 5 ¹ / ₂ " mineral wool insulation; Design G.	38 min.	38 min.			4	1-12	—
W-6-W-23	6"	2" × 4" stud wall; 16" o.c.; 1/2" gypsum board each side; 1/2" gypsum plaster each side.	N/A	60 min.			7	15	1

(continued)

**TABLE 1.3.2—continued
WOOD FRAME WALLS
4" TO LESS THAN 6" THICK.**

ITEM CODE	THICKNESS	CONSTRUCTION DETAILS	PERFORMANCE		REFERENCE NUMBER			NOTES	REC. HOURS
			LOAD	TIME	PRE-BMS-92	BMS-92	POST-BMS-92		
W-6-W-24	6"	2" × 4" stud wall; 16" o.c.; 1/2" gypsum board each side; 1/2" gypsum plaster each side.	N/A	68 min.			7	16	1
W-6-W-25	6 7/8"	2" × 4" stud wall; 18" o.c.; 3/4" gypsum plank each side; 3/16" gypsum plaster each side.	N/A	80 min.			7	15	1 1/3
W-5-W-26	5 1/8"	2" × 4" stud wall; 16" o.c.; 3/8" gypsum board each side; 3/16" gypsum plaster each side.	N/A	37 min.			7	15	1/2
W-5-W-27	5 3/4"	2" × 4" stud wall; 16" o.c.; 3/8" gypsum lath each side; 1/2" gypsum plaster each side.	N/A	52 min.			7	15	3/4
W-5-W-28	5"	2" × 4" stud wall; 16" o.c.; 1/2" gypsum board each side.	N/A	37 min.			7	16	1/2
W-5-W-29	5"	2" × 4" stud wall; 1/2" fiberboard both sides 14% M.C. with F.R. paint at 35 gm./ft. ² .	N/A	28 min.			7	15	1/3
W-4-W-30	4 3/4"	2" × 4" stud wall; Fire side: 1/2" (wood) fiberboard; Back side: 1/4" CAB; 16" o.c.	N/A	17 min.			7	15, 16	1/4
W-5-W-31	5 1/8"	2" × 4" stud wall; 16" o.c.; 1/2" fiberboard insulation with 1/32" asbestos (both sides of each board).	N/A	50 min.			7	16	3/4
W-4-W-32	4 1/4"	2" × 4" stud wall; 3/8" thick gypsum wallboard on both faces; insulated cavities.	See Note 23	25 min.		1		17, 18, 23	1/3
W-4-W-33	4 1/2"	2" × 4" stud wall; 1/2" thick gypsum wallboard on both faces.	See Note 17	40 min.		1		17, 23	1/3
W-4-W-34	4 1/2"	2" × 4" stud wall; 1/2" thick gypsum wallboard on both faces; insulated cavities.	See Note 17	45 min.		1		17, 18, 23	3/4
W-4-W-35	4 1/2"	2" × 4" stud wall; 1/2" thick gypsum wallboard on both faces; insulated cavities.	N/A	1 hr.		1		17, 18, 24	1
W-4-W-36	4 1/2"	2" × 4" stud wall; 1/2" thick, 1.1 lbs./ft. ² wood fiberboard sheathing on both faces.	See Note 23	15 min.		1		17, 23	1/4
W-4-W-37	4 1/2"	2" × 4" stud wall; 1/2" thick, 0.7 lb./ft. ² wood fiberboard sheathing on both faces.	See Note 23	10 min.		1		17, 23	1/6
W-4-W-38	4 1/2"	2" × 4" stud wall; 1/2" thick, flameproofed 1.6 lbs./ft. ² wood fiberboard sheathing on both faces.	See Note 23	30 min.		1		17, 23	1/2
W-4-W-39	4 1/2"	2" × 4" stud wall; 1/2" thick gypsum wallboard on both faces; insulated cavities.	See Note 23	1 hr.		1		17, 18, 23	1
W-4-W-40	4 1/2"	2" × 4" stud wall; 1/2" thick, 1:2; 1:3 gypsum plaster on wood lath on both faces.	See Note 23	30 min.		1		17, 21, 23	1/2
W-4-W-41	4 1/2"	2" × 4" stud wall; 1/2", 1:2; 1:3 gypsum plaster on wood lath on both faces; insulated cavities.	See Note 23	1 hr.		1		17, 18, 21, 24	1

(continued)

**TABLE 1.3.2—continued
WOOD FRAME WALLS
4" TO LESS THAN 6" THICK**

ITEM CODE	THICKNESS	CONSTRUCTION DETAILS	PERFORMANCE		REFERENCE NUMBER			NOTES	REC. HOURS
			LOAD	TIME	PRE-BMS-92	BMS-92	POST-BMS-92		
W-4-W-42	4 ^{1/2} "	2" × 4" stud wall; 1/2", 1:5; 1:7.5 lime plaster on wood lath on both wall faces.	See Note 23	30 min.		1		17, 21, 23	1/2
W-4-W-43	4 ^{1/2} "	2" × 4" stud wall; 1/2" thick 1:5; 1:7.5 lime plaster on wood lath on both faces; insulated cavities.	See Note 23	45 min.		1		17, 18, 21, 23	3/4
W-4-W-44	4 ^{5/8} "	2" × 4" stud wall; 3/16" thick cement-asbestos over 3/8" thick gypsum board on both faces.	See Note 23	1 hr.		1		23, 25, 26, 27	1
W-4-W-45	4 ^{5/8} "	2" × 4" stud wall; studs faced with 4" wide strips of 3/8" thick gypsum board; 3/16" thick gypsum cement-asbestos board on both faces; insulated cavities.	See Note 23	1 hr.		1		23, 25, 27, 28	1
W-4-W-46	4 ^{5/8} "	Same as W-4-W-45 but nonload bearing.	N/A	1 hr. 15 min.		1		24, 28	1 1/4
W-4-W-47	4 ^{7/8} "	2" × 4" stud wall; 3/16" thick cement-asbestos board over 1/2" thick gypsum sheathing on both faces.	See Note 23	1 hr. 15 min.		1		23, 25, 26, 27	1 1/4
W-4-W-48	4 ^{7/8} "	Same as W-4-W-47 but nonload bearing.	N/A	1 hr. 30 min.		1		24, 27	1 1/2
W-5-W-49	5"	2" × 4" stud wall; Exterior face: 3/4" wood sheathing; asbestos felt 14 lbs./100 ft. ² and 5/32" cement-asbestos shingles; Interior face: 4" wide strips of 3/8" gypsum board over studs; wall faced with 3/16" thick cement-asbestos board.	See Note 23	40 min.		1		18, 23, 25, 26, 29	2/3
W-5-W-50	5"	2" × 4" stud wall; Exterior face: as per W-5-W-49; Interior face: 9/16" composite board consisting of 7/16" thick wood fiber-board faced with 1/8" thick cement-asbestos board; Exterior side exposed to fire.	See Note 23	30 min.		1		23, 25, 26, 30	1/2
W-5-W-51	5"	Same as W-5-W-50 but interior side exposed to fire.	See Note 23	30 min.		1		23, 25, 26	1/2
W-5-W-52	5"	Same as W-5-W-49 but exterior side exposed to fire.	See Note 23	45 min.		1		18, 23, 25, 26	3/4
W-5-W-53	5"	2" × 4" stud wall; 3/4" thick T&G wood boards on both sides.	See Note 23	20 min.		1		17, 23	1/3
W-5-W-54	5"	Same as W-5-W-53 but with insulated cavities.	See Note 23	35 min.		1		17, 18, 23	1/2
W-5-W-55	5"	2" × 4" stud wall; 3/4" thick T&G wood boards on both sides with 30 lbs./100 ft. ² asbestos; paper, between studs and boards.	See Note 23	45 min.		1		17, 23	3/4
W-5-W-56	5"	2" × 4" stud wall; 1/2" thick, 1:2; 1:3 gypsum plaster on metal lath on both sides of wall.	See Note 23	45 min.		1		17, 21, 34	3/4

(continued)

**TABLE 1.3.2—continued
WOOD FRAME WALLS
4" TO LESS THAN 6" THICK**

ITEM CODE	THICKNESS	CONSTRUCTION DETAILS	PERFORMANCE		REFERENCE NUMBER			NOTES	REC. HOURS
			LOAD	TIME	PRE-BMS-92	BMS-92	POST-BMS-92		
W-5-W-57	5"	2" × 4" stud wall; 3/4" thick 2:1:8; 2:1:12 lime and Keene's cement plaster over metal lath on both sides of wall.	See Note 23	45 min.		1		17, 21, 23	1/2
W-5-W-58	5"	2" × 4" stud wall; 3/4" thick 2:1:8; 2:1:10 lime portland cement plaster over metal lath on both sides of wall.	See Note 23	30 min.		1		17, 21, 23	1/2
W-5-W-59	5"	2" × 4" stud wall; 3/4" thick 1:5; 1:7.5 lime plaster on metal lath on both sides of wall.	See Note 23	30 min.		1		17, 21, 23	1/2
W-5-W-60	5"	2" × 4" stud wall; 3/4" thick 1:1/30; 2; 1:1/30; 3 portland cement, asbestos fiber plaster on metal lath on both sides of wall.	See Note 23	45 min.		1		17, 21, 23	3/4
W-5-W-61	5"	2" × 4" stud wall; 3/4" thick 1:2; 1:3 portland cement plaster on metal lath on both sides of wall.	See Note 23	30 min.		1		17, 21, 23	1/2
W-5-W-62	5"	2" × 4" stud wall; 3/4" thick neat gypsum plaster on metal lath on both sides of wall.	N/A	1 hr. 30 min.		1		17, 22, 24	1 1/2
W-5-W-63	5"	2" × 4" stud wall; 3/4" thick neat gypsum plaster on metal lath on both sides of wall.	See Note 23	1 hr. 30 min.		1		17, 21, 23	1 1/2
W-5-W-64	5"	2" × 4" stud wall; 3/4" thick 1:2; 1:2 gypsum plaster on metal lath on both sides of wall; insulated cavities.	See Note 23	1 hr. 30 min.		1		17, 18, 21, 23	1 1/2
W-5-W-65	5"	2" × 4" stud wall; same as W-5-W-64 but cavities not insulated.	See Note 23	1 hr.		1		17, 21, 23	1
W-5-W-66	5"	2" × 4" stud wall; 3/4" thick 1:2; 1:3 gypsum plaster on metal lath on both sides of wall; insulated cavities.	See Note 23	1 hr. 15 min.		1		17, 18, 21, 23	1 1/4
W-5-W-67	5 1/16"	Same as W-5-W-49 except cavity insulation of 1.75 lbs./ft. ² mineral wool bats; rating applies when either wall side exposed to fire.	See Note 23	1 hr. 15 min.		1		23, 26, 25	1 1/4
W-5-W-68	5 1/4"	2" × 4" stud wall, 7/8" thick 1:2; 1:3 gypsum plaster on metal lath on both sides of wall; insulated cavities.	See Note 23	1 hr. 30 min.		1		17, 18, 21, 23	1 1/2
W-5-W-69	5 1/4"	2" × 4" stud wall; 7/8" thick neat gypsum plaster applied on metal lath on both sides of wall.	N/A	1 hr. 45 min.		1		17, 22, 24	1 3/4
W-5-W-70	5 1/4"	2" × 4" stud wall; 1/2" thick neat gypsum plaster on 3/8" plain gypsum lath on both sides of wall.	See Note 23	1 hr.		1		17, 22, 23	1
W-5-W-71	5 1/4"	2" × 4" stud wall; 1/2" thick of 1:2; 1:2 gypsum plaster on 3/8" thick plain gypsum lath with 1 3/4" × 1 3/4" metal lath pads nailed 8" o.c. vertically and 16" o.c. horizontally on both sides of wall.	See Note 23	1 hr.		1		17, 21, 23	1
W-5-W-72	5 1/4"	2" × 4" stud wall; 1/2" thick of 1:2; 1:2 gypsum plaster on 3/8" perforated gypsum lath, one 3/4" diameter hole or larger per 16" square of lath surface, on both sides of wall.	See Note 23	1 hr.		1		17, 21, 23	1

(continued)

**TABLE 1.3.2—continued
WOOD FRAME WALLS
4" TO LESS THAN 6" THICK**

ITEM CODE	THICKNESS	CONSTRUCTION DETAILS	PERFORMANCE		REFERENCE NUMBER			NOTES	REC. HOURS
			LOAD	TIME	PRE-BMS-92	BMS-92	POST-BMS-92		
W-5-W-73	5 1/4"	2" × 4" stud wall; 1/2" thick of 1:2; 1:2 gypsum plaster on 3/8" gypsum lath (plain, indented or perforated) on both sides of wall.	See Note 23	45 min.		1		17, 21, 23	3/4
W-5-W-74	5 1/4"	2" × 4" stud wall; 7/8" thick of 1:2; 1:3 gypsum plaster over metal lath on both sides of wall.	See Note 23	1 hr.		1		17, 21, 23	1
W-5-W-75	5 1/4"	2" × 4" stud wall; 7/8" thick of 1:1/30; 2; 1:1/30; 3 portland cement, asbestos plaster applied over metal lath on both sides of wall.	See Note 23	1 hr.		1		17, 21, 23	1
W-5-W-76	5 1/4"	2" × 4" stud wall; 7/8" thick of 1:2; 1:3 portland cement plaster over metal lath on both sides of wall.	See Note 23	45 min.		1		17, 21, 23	3/4
W-5-W-77	5 1/2"	2" × 4" stud wall; 1" thick neat gypsum plaster over metal lath on both sides of wall; nonload bearing.	N/A	2 hrs.		1		17, 22, 24	2
W-5-W-78	5 1/2"	2" × 4" stud wall; 1/2" thick of 1:2; 1:2 gypsum plaster on 1/2" thick, 0.7 lb./ft. ² wood fiberboard on both sides of wall.	See Note 23	35 min.		1		17, 21, 23	1/2
W-4-W-79	4 3/4"	2" × 4" wood stud wall; 1/2" thick of 1:2; 1:2 gypsum plaster over wood lath on both sides of wall; mineral wool insulation.	N/A	1 hr.			43	21, 31, 35, 38	1
W-4-W-80	4 3/4"	Same as W-4-W-79 but uninsulated.	N/A	35 min.			43	21, 31, 35	1/2
W-4-W-81	4 3/4"	2" × 4" wood stud wall; 1/2" thick of 3:1:8; 3:1:12 lime, Keene's cement, sand plaster over wood lath on both sides of wall; mineral wool insulation.	N/A	1 hr.			43	21, 31, 35, 40	1
W-4-W-82	4 3/4"	2" × 4" wood stud wall; 1/2" thick of 1:6 1/4; 1:6 1/4 lime Keene's cement plaster over wood lath on both sides of wall; mineral wool insulation.	N/A	30 min.			43	21, 31, 35, 40	1/2
W-4-W-83	4 3/4"	2" × 4" wood stud wall; 1/2" thick of 1:5; 1:7.5 lime plaster over wood lath on both sides of wall.	N/A	30 min.			43	21, 31, 35	1/2
W-5-W-84	5 1/8"	2" × 4" wood stud wall; 1 1/16" thick of 1:5; 1:7.5 lime plaster over wood lath on both sides of wall; mineral wool insulation.	N/A	45 min.			43	21, 31, 35, 39	3/4
W-5-W-85	5 1/4"	2" × 4" wood stud wall; 3/4" thick of 1:5; 1:7 lime plaster over wood lath on both sides of wall; mineral wool insulation.	N/A	40 min.			43	21, 31, 35, 40	2/3
W-5-W-86	5 1/4"	2" × 4" wood stud wall; 1/2" thick of 2:1:12 lime, Keene's cement and sand scratch coat; 1/2" thick 2:1:18 lime, Keene's cement and sand brown coat over wood lath on both sides of wall; mineral wool insulation.	N/A	1 hr.			43	21, 31, 35, 40	1
W-5-W-87	5 1/4"	2" × 4" wood stud wall; 1/2" thick of 1:2; 1:2 gypsum plaster over 3/8" plaster board on both sides of wall.	N/A	45 min.			43	21, 31	3/4

(continued)

**TABLE 1.3.2—continued
WOOD FRAME WALLS
4" TO LESS THAN 6" THICK**

ITEM CODE	THICKNESS	CONSTRUCTION DETAILS	PERFORMANCE		REFERENCE NUMBER			NOTES	REC. HOURS
			LOAD	TIME	PRE-BMS-92	BMS-92	POST-BMS-92		
W-5-W-88	5 1/4"	2" × 4" wood stud wall; 1/2" thick of 1:2; 1:2 gypsum plaster over 3/8" gypsum lath on both sides of wall.	N/A	45 min.			43	21, 31	3/4
W-5-W-89	5 1/4"	2" × 4" wood stud wall; 1/2" thick of 1:2; 1:2 gypsum plaster over 3/8" gypsum lath on both sides of wall.	N/A	1 hr.			43	21, 31, 33	1
W-5-W-90	5 1/4"	2" × 4" wood stud wall; 1/2" thick neat plaster over 3/8" thick gypsum lath on both sides of wall.	N/A	1 hr.			43	21, 22, 31	1
W-5-W-91	5 1/4"	2" × 4" wood stud wall; 1/2" thick of 1:2; 1:2 gypsum plaster over 3/8" thick indented gypsum lath on both sides of wall.	N/A	45 min.			43	21, 31	3/4
W-5-W-92	5 1/4"	2" × 4" wood stud wall; 1/2" thick of 1:2; 1:2 gypsum plaster over 3/8" thick perforated gypsum lath on both sides of wall.	N/A	45 min.			43	21, 31, 34	3/4
W-5-W-93	5 1/4"	2" × 4" wood stud wall; 1/2" thick of 1:2; 1:2 gypsum plaster over 3/8" perforated gypsum lath on both sides of wall.	N/A	1 hr.			43	21, 31	1
W-5-W-94	5 1/4"	2" × 4" wood stud wall; 1/2" thick of 1:2; 1:2 gypsum plaster over 3/8" thick perforated gypsum lath on both sides of wall.	N/A	45 min.			43	21, 31, 34	3/4
W-5-W-95	5 1/2"	2" × 4" wood stud wall; 1/2" thick of 1:2; 1:2 gypsum plaster over 1/2" thick wood fiberboard plaster base on both sides of wall.	N/A	35 min.			43	21, 31, 36	1/2
W-5-W-96	5 3/4"	2" × 4" wood stud wall; 1/2" thick of 1:2; 1:2 gypsum plaster over 7/8" thick flameproofed wood fiberboard on both sides of wall.	N/A	1 hr.			43	21, 31, 37	1

For SI: 1 inch = 25.4 mm, 1 foot = 305 mm, 1 pound = 0.004448 kN, 1 pound per square inch = 0.00689 MPa, 1 pound per square foot = 47.9 N/m².

Notes:

1. All specimens 8 feet or 8 feet 8 inches by 10 feet 4 inches, i.e. one-half of furnace size. See Note 42 for design cross section.
2. Specimens tested in tandem (two per exposure).
3. Test per ASA No. A2-1934 except where unloaded. Also, panels were of "half" size of furnace opening. Time value signifies a thermal failure time.
4. Two-inch by 4-inch studs: 16 inches on center.; where 10 feet 4 inches, blocking at 2-foot 4-inch height.
5. Facing 4 feet by 8 feet, cement-asbestos board sheets, 3/16 inch thick.
6. Sheathing (diagonal): 25/22 inch by 5 1/2 inch, 1 inch by 6 inches pine.
7. Facing shingles: 24 inches by 12 inches by 5/32 inch where used.
8. Asbestos felt: asphalt sat between sheathing and shingles.
9. Load: 30,500 pounds or 360 psi/stud where load was tested.
10. Walls were tested beyond achievement of first test end point. A load-bearing time in excess of performance time indicates that although thermal criteria were exceeded, load-bearing ability continued.
11. Wall was rated for one hour combustible use in original source.
12. Hose steam test specimen. See table entry of similar design above for recommended rating.
13. Rated one and one-fourth hour load bearing. Rated one and one-half hour nonload bearing.
14. Failed hose stream.
15. Test terminated due to flame penetration.
16. Test terminated—local back face temperature rise.
17. Nominal 2-inch by 4-inch wood studs of No. 1 common or better lumber set edgewise. Two-inch by four-inch plates at top and bottom and blocking at mid height of wall.
18. Cavity insulation consists of rock wool bats 1.0 lb./ft.² of filled cavity area.
19. Cavity insulation consists of glass wool bats 0.6 lb./ft.² of filled cavity area.
20. Cavity insulation consists of blown-in forck wool 2.0 lbs./ft.² of filled cavity area
21. Mix proportions for plastered walls as follows: first ratio indicates scratch coat mix, weight of dry plaster: dry sand; second ratio indicates brown coat mix.
22. "Neat" plaster is taken to mean unsanded wood-fiber gypsum plaster.
23. Load: 360 psi of net stud cross sectional area.
24. Rated as nonload bearing.

(continued)

RESOURCE A

**TABLE 1.3.2—continued
WOOD FRAME WALLS
4" TO LESS THAN 6" THICK**

25. Nominal 2-inch by 4-inch studs per Note 17, spaced at 16 inches on center.
26. Horizontal joints in facing material supported by 2-inch by 4-inch blocking within wall.
27. Facings secured with 6d casing nails. Nail holes predrilled and were 0.02 to 0.03 inch smaller than nail diameter.
28. Cavity insulation consists of mineral wool bats weighing 2 lbs./ft.² of filled cavity area.
29. Interior wall face exposed to fire.
30. Exterior wall faced exposed to fire.
31. Nominal 2-inch by 4-inch studs of yellow pine or Douglas-fir spaced 16 inches on center in a single row.
32. Studs as in Note 31 except double row, with studs in rows staggered.
33. Six roofing nails with metal-lath pads around heads to each 16-inch by 48-inch lath.
34. Areas of holes less than 2³/₄ percent of area of lath.
35. Wood laths were nailed with either 3d or 4d nails, one nail to each bearing, and the end joining broken every seventh course.
36. One-half-inch thick fiberboard plaster base nailed with 3d or 4d common wire nails spaced 4 to 6 inches on center.
37. Seven-eighths-inch thick fiberboard plaster base nailed with 5d common wire nails spaced 4 to 6 inches on center.
38. Mineral wood bats 1.05 to 1.25 lbs./ft.² with waterproofed-paper backing.
39. Blown-in mineral wool insulation, 2.2 lbs./ft.².
40. Mineral wool bats, 1.4 lbs./ft.² with waterproofed-paper backing.
41. Mineral wood bats, 0.9 lb./ft.².
42. See wall design diagram, below.

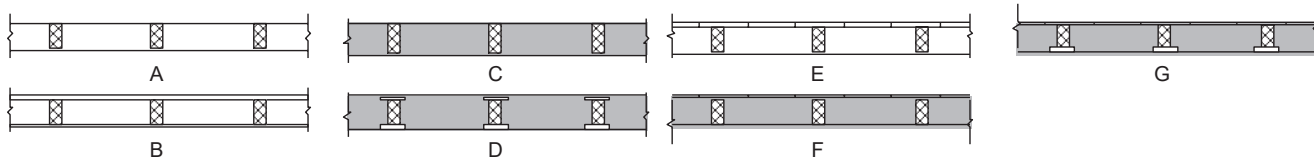

43. Duplicate specimen of W-4-W-7, tested simultaneously with W-4-W-7 in 18-foot test furnace.

**TABLE 1.3.3
WOOD FRAME WALLS
6" TO LESS THAN 8" THICK**

ITEM CODE	THICKNESS	CONSTRUCTION DETAILS	PERFORMANCE		REFERENCE NUMBER			NOTES	REC. HOURS
			LOAD	TIME	PRE-BMS-92	BMS-92	POST-BMS-92		
W-6-W-1	6 ¹ / ₄ "	2 × 4 stud wall; 1/2" thick, 1:2; 1:2 gypsum plaster on 7/8" flameproofed wood fiberboard weighing 2.8 lbs./ft. ² on both sides of wall.	See Note 3	1 hr.		1		1-3	1
W-6-W-2	6 ¹ / ₂ "	2 × 4 stud wall; 1/2" thick, 1:3; 1:3 gypsum plaster on 1" thick magnesium oxysulfate wood fiberboard on both sides of wall.	See Note 3	45 min.		1		1-3	3/4
W-7-W-3	7 ¹ / ₄ "	Double row of 2 × 4 studs, 1/2" thick of 1:2; 1:2 gypsum plaster applied over 3/8" thick perforated gypsum lath on both sides of wall; mineral wool insulation.	N/A	1 hr.			43	2, 4, 5	1
W-7-W-4	7 ¹ / ₂ "	Double row of 2 × 4 studs, 5/8" thick of 1:2; 1:2 gypsum plaster applied over 3/8" thick perforated gypsum lath over laid with 2" × 2", 16 gage wire fabric, on both sides of wall.	N/A	1 hr. 15 min.			43	2, 4	1 ¹ / ₄

For SI: 1 inch = 25.4 mm, 1 pound = 0.004448 kN, 1 pound per square inch = 0.00689 MPa, 1 pound per square foot = 47.9 N/m².

Notes:

- Nominal 2-inch by 4-inch wood studs of No. 1 common or better lumber set edgewise. Two-inch by 4-inch plates at top and bottom and blocking at mid height of wall.
- Mix proportions for plastered walls as follows: first ratio indicates scratch coat mix, weight of dry plaster: dry sand; second ratio indicates brown coat mix.
- Load: 360 psi of net stud cross sectional area.
- Nominal 2-inch by 4-inch studs of yellow pine or Douglas-fir spaced 16 inches in a double row, with studs in rows staggered.
- Mineral wool bats, 0.19 lb./ft.²

**TABLE 1.4.1
MISCELLANEOUS MATERIALS WALLS
0" TO LESS THAN 4" THICK**

ITEM CODE	THICKNESS	CONSTRUCTION DETAILS	PERFORMANCE		REFERENCE NUMBER			NOTES	REC. HOURS
			LOAD	TIME	PRE-BMS-92	BMS-92	POST-BMS-92		
W-3-Mi-1	3 ⁷ / ₈ "	Glass brick wall: (bricks 5 ³ / ₄ " × 5 ³ / ₄ " × 3 ⁷ / ₈ ") 1/4" mortar bed, cement/lime/sand; mounted in brick (9") wall with mastic and 1/2" asbestos rope.	N/A	1 hr.			7	1, 2	1
W-3-Mi-2	3"	Core: 2" magnesium oxysulfate wood-fiber blocks; laid in portland cement-lime mortar; Facings: on both sides; see Note 3.	N/A	1 hr.		1		3	1
W-3-Mi-3	3 ⁷ / ₈ "	Core: 8" × 4 ⁷ / ₈ " glass blocks 3 ⁷ / ₈ " thick weighing 4 lbs. each; laid in portland cement-lime mortar; horizontal mortar joints reinforced with metal lath.	N/A	15 min.		1			1/4

For SI: 1 inch = 25.4 mm, 1 pound = 0.004448 kN.

Notes:

- No failure reached at 1 hour.
- These glass blocks are assumed to be solid based on other test data available for similar but hollow units which show significantly reduced fire endurance.
- Minimum of 1/2 inch of 1:3 sanded gypsum plaster required to develop this rating.

**TABLE 1.4.2
MISCELLANEOUS MATERIALS WALLS
4" TO LESS THAN 6" THICK**

ITEM CODE	THICKNESS	CONSTRUCTION DETAILS	PERFORMANCE		REFERENCE NUMBER			NOTES	REC. HOURS
			LOAD	TIME	PRE-BMS-92	BMS-92	POST-BMS-92		
W-4-Mi-1	4"	Core: 3" magnesium oxysulfate wood-fiber blocks; laid in portland cement mortar; Facings: both sides; see Note 1.	N/A	2 hrs.		1			2

For SI: 1 inch = 25.4 mm.

Notes:

1. One-half inch sanded gypsum plaster. Voids in hollow blocks to be not more than 30 percent.

**FIGURE 1.5.1
FINISH RATINGS—INORGANIC MATERIALS**

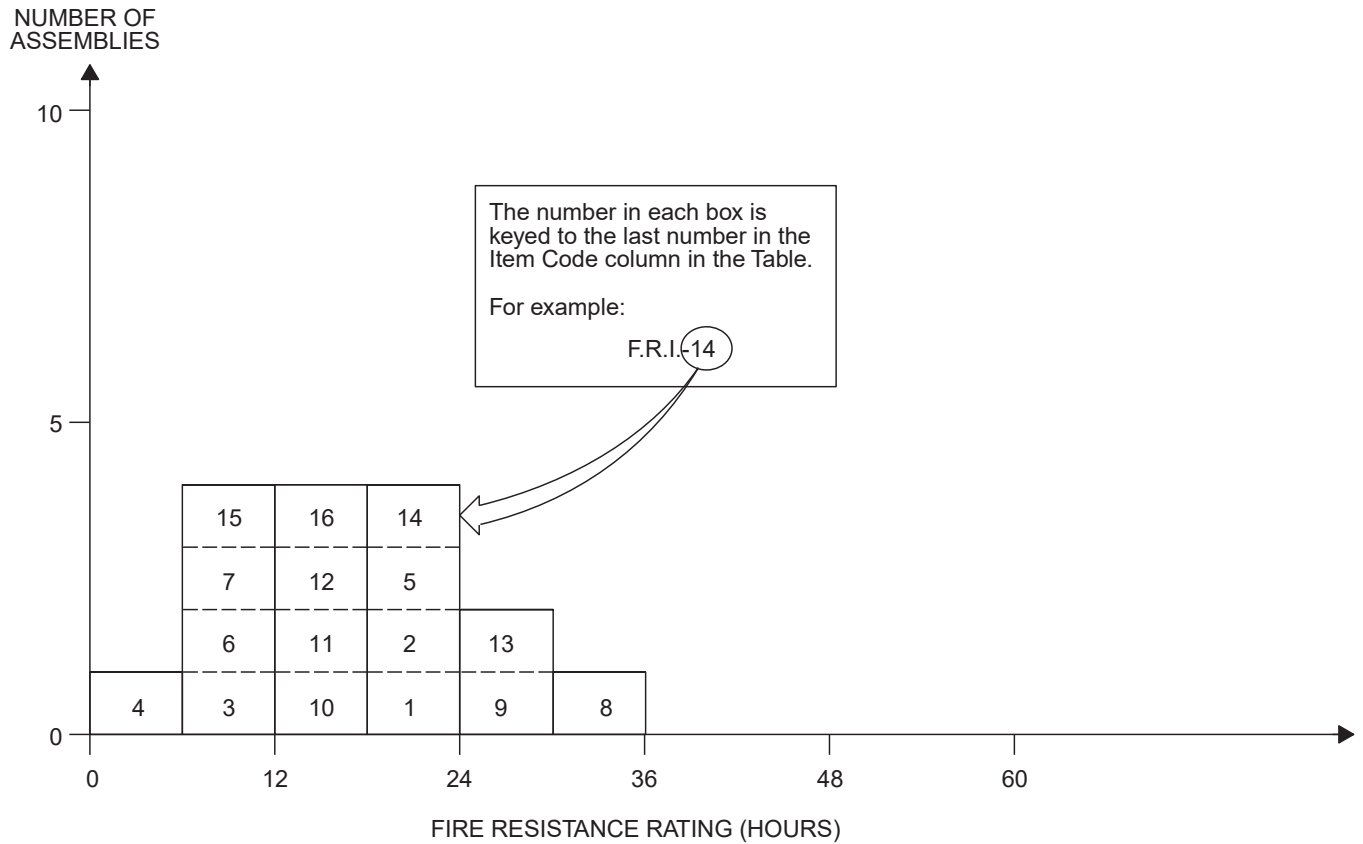

**TABLE 1.5.1
FINISH RATINGS—INORGANIC MATERIALS**

ITEM CODE	THICKNESS	CONSTRUCTION DETAILS	PERFORMANCE	REFERENCE NUMBER			NOTES	REC. F.R. (MIN.)
			FINISH RATING	PRE-BMS-92	BMS-92	POST-BMS-92		
F.R.-I-1	9/16"	3/8" gypsum wallboard faced with 3/16" cement-asbestos board.	20 minutes		1		1, 2	15
F.R.-I-2	11/16"	1/2" gypsum sheathing faced with 3/16" cement-asbestos board.	20 minutes		1		1, 2	20
F.R.-I-3	3/16"	3/16" cement-asbestos board over uninsulated cavity.	10 minutes		1		1, 2	5
F.R.-I-4	3/16"	3/16" cement-asbestos board over insulated cavities.	5 minutes		1		1, 2	5
F.R.-I-5	3/4"	3/4" thick 1:2; 1:3 gypsum plaster over paper backed metal lath.	20 minutes		1		1, 2, 3	20
F.R.-I-6	3/4"	3/4" thick portland cement plaster on metal lath.	10 minutes		1		1, 2	10
F.R.-I-7	3/4"	3/4" thick 1:5; 1:7.5 lime plaster on metal lath.	10 minutes		1		1, 2	10
F.R.-I-8	1"	1" thick neat gypsum plaster on metal lath.	35 minutes		1		1, 2, 4	35
F.R.-I-9	3/4"	3/4" thick neat gypsum plaster on metal lath.	30 minutes		1		1, 2, 4	30

(continued)

RESOURCE A

**TABLE 1.5.1—continued
FINISH RATINGS—INORGANIC MATERIALS**

ITEM CODE	THICKNESS	CONSTRUCTION DETAILS	PERFORMANCE	REFERENCE NUMBER			NOTES	REC. F.R. (MIN.)
			FINISH RATING	PRE-BMS-92	BMS-92	POST-BMS-92		
F.R.-I-10	3/4"	3/4" thick 1:2; 1:2 gypsum plaster on metal lath.	15 minutes		1		1, 2, 3	15
F.R.-I-11	1/2"	Same as F.R.-1-7, except 1/2" thick on wood lath.	15 minutes		1		1, 2, 3	15
F.R.-I-12	1/2"	1/2" thick 1:2; 1:3 gypsum plaster on wood lath.	15 minutes		1		1, 2, 3	15
F.R.-I-13	7/8"	1/2" thick 1:2; 1:2 gypsum plaster on 3/8" perforated gypsum lath.	30 minutes		1		1, 2, 3	30
F.R.-I-14	7/8"	1/2" thick 1:2; 1:2 gypsum plaster on 3/8" thick plain or indented gypsum plaster.	20 minutes		1		1, 2, 3	20
F.R.-I-15	3/8"	3/8" gypsum wallboard.	10 minutes		1		1, 2	10
F.R.-I-16	1/2"	1/2" gypsum wallboard.	15 minutes		1		1, 2	15

For SI: 1 inch = 25.4 mm, °C = [(°F) - 32]/1.8.

Notes:

1. The finish rating is the time required to obtain an average temperature rise of 250°F, or a single point rise of 325°F, at the interface between the material being rated and the substrate being protected.
2. Tested in accordance with the Standard Specifications for Fire Tests of Building Construction and Materials, ASA No. A2-1932.
3. Mix proportions for plasters as follows: first ratio, dry weight of plaster: dry weight of sand for scratch coat; second ratio, plaster: sand for brown coat.
4. Neat plaster means unsanded wood-fiber gypsum plaster.

General Note:

The finish rating of modern building materials can be found in the current literature.

**TABLE 1.5.2
FINISH RATINGS—ORGANIC MATERIALS**

ITEM CODE	THICKNESS	CONSTRUCTION DETAILS	PERFORMANCE	REFERENCE NUMBER			NOTES	REC. F.R. (MIN.)
			FINISH RATING	PRE-BMS-92	BMS-92	POST-BMS-92		
F.R.-O-1	9/16"	7/16" wood fiberboard faced with 1/8" cement-asbestos board.	15 minutes		1		1, 2	15
F.R.-O-2	29/32"	3/4" wood sheathing, asbestos felt weighing 14 lbs./100 ft. ² and 5/32" cement-asbestos shingles.	20 minutes		1		1, 2	20
F.R.-O-3	1 1/2"	1" thick magnesium oxysulfate wood fiberboard faced with 1:3; 1:3 gypsum plaster, 1/2" thick.	20 minutes		1		1, 2, 3	20
F.R.-O-4	1/2"	1/2" thick wood fiberboard.	5 minutes		1		1, 2	5
F.R.-O-5	1/2"	1/2" thick flameproofed wood fiberboard.	10 minutes		1		1, 2	10
F.R.-O-6	1"	1/2" thick wood fiberboard faced with 1/2" thick 1:2; 1:2 gypsum plaster.	15 minutes		1		1, 2, 3	30
F.R.-O-7	1 3/8"	7/8" thick flameproofed wood fiberboard faced with 1/2" thick 1:2; 1:2 gypsum plaster.	30 minutes		1		1, 2, 3	30
F.R.-O-8	1 1/4"	1 1/4" thick plywood.	30 minutes			35		30

For SI: 1 inch = 25.4 mm, 1 pound = 0.004448 kN, 1 pound per square foot = 47.9 N/m², °C = [(°F) - 32]/1.8.

Notes:

1. The finish rating is the time required to obtain an average temperature rise of 250°F, or a single point rise of 325°F, at the interface between the material being rated and the substrate being protected.
2. Tested in accordance with the Standard Specifications for Fire Tests of Building Construction and Materials, ASA No. A2-1932.
3. Plaster ratios as follows: first ratio is for scratch coat, weight of dry plaster: weight of dry sand; second ratio is for the brown coat.

General Note:

The finish rating of thinner materials, particularly thinner woods, have not been listed because the possible effects of shrinkage, warpage and aging cannot be predicted.

**SECTION II
COLUMNS**

**TABLE 2.1.1
REINFORCED CONCRETE COLUMNS
MINIMUM DIMENSION 0" TO LESS THAN 6"**

ITEM CODE	MINIMUM DIMENSION	CONSTRUCTION DETAILS	PERFORMANCE		REFERENCE NUMBER			NOTES	REC. HOURS
			LOAD	TIME	PRE-BMS-92	BMS-92	POST-BMS-92		
C-6-RC-1	6"	6" × 6" square columns; gravel aggregate concrete (4030 psi); Reinforcement: vertical, four 7/8" rebars; horizontal, 5/16" ties at 6" pitch; Cover: 1".	34.7 tons	62 min.			7	1, 2	1
C-6-RC-2	6"	6" × 6" square columns; gravel aggregate concrete (4200 psi); Reinforcement: vertical, four 1/2" rebars; horizontal, 5/16" ties at 6" pitch; Cover: 1".	21 tons	69 min.			7	1, 2	1

Notes:

1. Collapse.
2. British Test

**FIGURE 2.1.2
REINFORCED CONCRETE COLUMNS
MINIMUM DIMENSION 10" TO LESS THAN 12"**

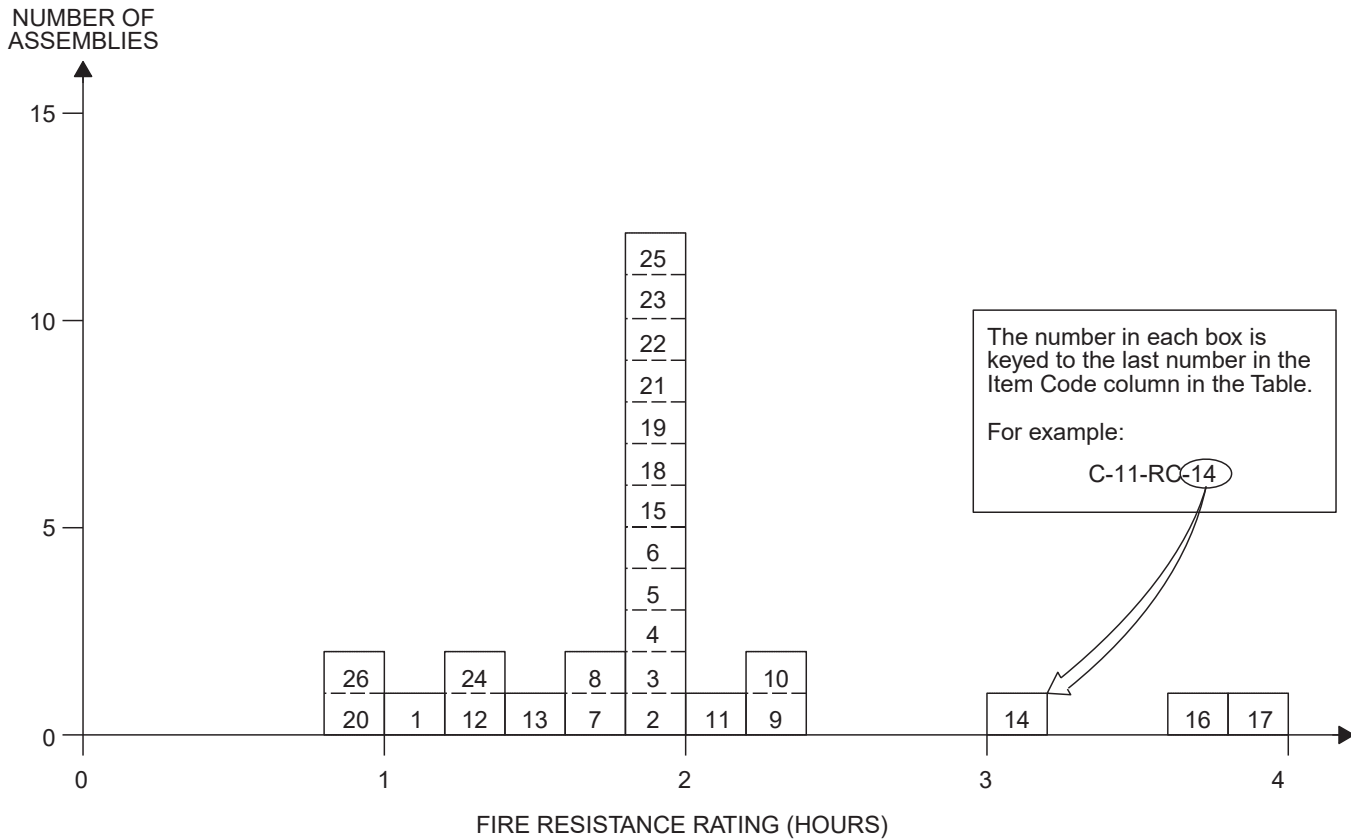

**TABLE 2.1.2
REINFORCED CONCRETE COLUMNS
MINIMUM DIMENSION 10" TO LESS THAN 12"**

ITEM CODE	MINIMUM DIMENSION	CONSTRUCTION DETAILS	PERFORMANCE		REFERENCE NUMBER			NOTES	REC. HOURS
			LOAD	TIME	PRE-BMS-92	BMS-92	POST-BMS-92		
C-10-RC-1	10"	10" square columns; aggregate concrete (4260 psi); Reinforcement: vertical, four 1 1/4" rebars; horizontal, 3/8" ties at 6" pitch; Cover: 1 1/4".	92.2 tons	1 hr. 2 min.			7	1	1
C-10-RC-2	10"	10" square columns; aggregate concrete (2325 psi); Reinforcement: vertical, four 1/2" rebars; horizontal, 5/16" ties at 6" pitch; Cover: 1".	46.7 tons	1 hr. 52 min.			7	1	1 3/4
C-10-RC-3	10"	10" square columns; aggregate concrete (5370 psi); Reinforcement: vertical, four 1/2" rebars; horizontal, 5/16" ties at 6" pitch; Cover: 1".	46.5 tons	2 hrs.			7	2, 3, 11	2
C-10-RC-4	10"	10" square columns; aggregate concrete (5206 psi); Reinforcement: vertical, four 1/2" rebars; horizontal, 5/16" ties at 6" pitch; Cover: 1".	46.5 tons	2 hrs.			7	2, 7	2
C-10-RC-5	10"	10" square columns; aggregate concrete (5674 psi); Reinforcement: vertical, four 1/2" rebars; horizontal, 5/16" ties at 6" pitch; Cover: 1".	46.7 tons	2 hrs.			7	1	2

(continued)

**TABLE 2.1.2—continued
REINFORCED CONCRETE COLUMNS
MINIMUM DIMENSION 10" TO LESS THAN 12"**

ITEM CODE	MINIMUM DIMENSION	CONSTRUCTION DETAILS	PERFORMANCE		REFERENCE NUMBER			NOTES	REC. HOURS
			LOAD	TIME	PRE-BMS-92	BMS-92	POST-BMS-92		
C-10-RC-6	10"	10" square columns; aggregate concrete (5150 psi); Reinforcement: vertical, four 1½" rebars; horizontal, 5/16" ties at 6" pitch; Cover: 1".	66 tons	1 hr. 43 min.			7	1	1¾
C-10-RC-7	10"	10" square columns; aggregate concrete (5580 psi); Reinforcement: vertical, four 1½" rebars; horizontal, 5/16" ties at 6" pitch; Cover: 1⅛".	62.5 tons	1 hr. 38 min.			7	1	1½
C-10-RC-8	10"	10" square columns; aggregate concrete (4080 psi); Reinforcement: vertical, four 1⅛" rebars; horizontal, 5/16" ties at 6" pitch; Cover: 1⅛".	72.8 tons	1 hr. 48 min.			7	1	1¾
C-10-RC-9	10"	10" square columns; aggregate concrete (2510 psi); Reinforcement: vertical, four 1½" rebars; horizontal, 5/16" ties at 6" pitch; Cover: 1".	51 tons	2 hrs. 16 min.			7	1	2¼
C-10-RC-10	10"	10" square columns; aggregate concrete (2170 psi); Reinforcement: vertical, four 1½" rebars; horizontal, 5/16" ties at 6" pitch; Cover: 1".	45 tons	2 hrs. 14 min.			7	12	2¼
C-10-RC-11	10"	10" square columns; gravel aggregate concrete (4015 psi); Reinforcement: vertical, four 1½" rebars; horizontal, 5/16" ties at 6" pitch; Cover: 1⅛".	46.5 tons	2 hrs. 6 min.			7	1	2
C-11-RC-12	11"	11" square columns; gravel aggregate concrete (4150 psi); Reinforcement: vertical, four 1¼" rebars; horizontal, 3/8" ties at 7½" pitch; Cover: 1½".	61 tons	1 hr. 23 min.			7	1	1¼
C-11-RC-13	11"	11" square columns; gravel aggregate concrete (4380 psi); Reinforcement: vertical, four 1¼" rebars; horizontal, 3/8" ties at 7½" pitch; Cover: 1½".	61 tons	1 hr. 26 min.			7	1	1¼
C-11-RC-14	11"	11" square columns; gravel aggregate concrete (4140 psi); Reinforcement: vertical, four 1¼" rebars; horizontal, 3/8" ties at 7½" pitch; steel mesh around reinforcement; Cover: 1½".	61 tons	3 hrs. 9 min.			7	1	3
C-11-RC-15	11"	11" square columns; slag aggregate concrete (3690 psi); Reinforcement: vertical, four 1¼" rebars; horizontal, 3/8" ties at 7½" pitch; Cover: 1½".	91 tons	2 hrs.			7	2, 3, 4, 5	2
C-11-RC-16	11"	11" square columns; limestone aggregate concrete (5230 psi); Reinforcement: vertical, four 1¼" rebars; horizontal, 3/8" ties at 7½" pitch; Cover: 1½".	91.5 tons	3 hrs. 41 min.			7	1	3½
C-11-RC-17	11"	11" square columns; limestone aggregate concrete (5530 psi); Reinforcement: vertical, four 1¼" rebars; horizontal, 3/8" ties at 7½" pitch; Cover: 1½".	91.5 tons	3 hrs. 47 min.			7	1	3½

(continued)

**TABLE 2.1.2—continued
REINFORCED CONCRETE COLUMNS
MINIMUM DIMENSION 10" TO LESS THAN 12"**

ITEM CODE	MINIMUM DIMENSION	CONSTRUCTION DETAILS	PERFORMANCE		REFERENCE NUMBER			NOTES	REC. HOURS
			LOAD	TIME	PRE-BMS-92	BMS-92	POST-BMS-92		
C-11-RC-18	11"	11" square columns; limestone aggregate concrete (5280 psi); Reinforcement: vertical, four 1 ¹ / ₄ " rebars; horizontal, 3 ³ / ₈ " ties at 7 ¹ / ₂ " pitch; Cover: 1 ¹ / ₂ ".	91.5 tons	2 hrs.			7	2, 3, 4, 6	2
C-11-RC-19	11"	11" square columns; limestone aggregate concrete (4180 psi); Reinforcement: vertical, four 5 ⁵ / ₈ " rebars; horizontal, 3 ³ / ₈ " ties at 7" pitch; Cover: 1 ¹ / ₂ ".	71.4 tons	2 hrs.			7	2, 7	2
C-11-RC-20	11"	11" square columns; gravel concrete (4530 psi); Reinforcement: vertical, four 5 ⁵ / ₈ " rebars; horizontal, 3 ³ / ₈ " ties at 7" pitch; Cover: 1 ¹ / ₂ " with 1 ¹ / ₂ " plaster.	58.8 tons	2 hrs.			7	2, 3, 9	1 ¹ / ₄
C-11-RC-21	11"	11" square columns; gravel concrete (3520 psi); Reinforcement: vertical, four 5 ⁵ / ₈ " rebars; horizontal, 3 ³ / ₈ " ties at 7" pitch; Cover: 1 ¹ / ₂ ".	Variable	1 hr. 24 min.			7	1, 8	2
C-11-RC-22	11"	11" square columns; aggregate concrete (3710 psi); Reinforcement: vertical, four 5 ⁵ / ₈ " rebars; horizontal, 3 ³ / ₈ " ties at 7" pitch; Cover: 1 ¹ / ₂ ".	58.8 tons	2 hrs.			7	2, 3, 10	2
C-11-RC-23	11"	11" square columns; aggregate concrete (3190 psi); Reinforcement: vertical, four 5 ⁵ / ₈ " rebars; horizontal, 3 ³ / ₈ " ties at 7" pitch; Cover: 1 ¹ / ₂ ".	58.8 tons	2 hrs.			7	2, 3, 10	2
C-11-RC-24	11"	11" square columns; aggregate concrete (4860 psi); Reinforcement: vertical, four 5 ⁵ / ₈ " rebars; horizontal, 3 ³ / ₈ " ties at 7" pitch; Cover: 1 ¹ / ₂ ".	86.1 tons	1 hr. 20 min.			7	1	1 ¹ / ₃
C-11-RC-25	11"	11" square columns; aggregate concrete (4850 psi); Reinforcement: vertical, four 5 ⁵ / ₈ " rebars; horizontal, 3 ³ / ₈ " ties at 7" pitch; Cover: 1 ¹ / ₂ ".	58.8 tons	1 hr. 59 min.			7	1	1 ³ / ₄
C-11-RC-26	11"	11" square columns; aggregate concrete (3834 psi); Reinforcement: vertical, four 5 ⁵ / ₈ " rebars; horizontal, 5 ⁵ / ₁₆ " ties at 4 ¹ / ₂ " pitch; Cover: 1 ¹ / ₂ ".	71.4 tons	53 min.			7	1	3 ³ / ₄

For SI: 1 inch = 25.4 mm, 1 pound per square inch = 0.00689 MPa, 1 ton = 8.896 kN.

Notes:

1. Failure mode—collapse.
2. Passed 2 hour fire exposure.
3. Passed hose stream test.
4. Reloaded effectively after 48 hours but collapsed at load in excess of original test load.
5. Failing load was 150 tons.
6. Failing load was 112 tons.
7. Failed during hose stream test.
8. Range of load 58.8 tons (initial) to 92 tons (92 minutes) to 60 tons (80 minutes).
9. Collapsed at 44 tons in reload after 96 hours.
10. Withstood reload after 72 hours.
11. Collapsed on reload after 48 hours.

**TABLE 2.1.3
REINFORCED CONCRETE COLUMNS
MINIMUM DIMENSION 12" TO LESS THAN 14"**

ITEM CODE	MINIMUM DIMENSION	CONSTRUCTION DETAILS	PERFORMANCE		REFERENCE NUMBER			NOTES	REC. HOURS
			LOAD	TIME	PRE-BMS-92	BMS-92	POST-BMS-92		
C-12-RC-1	12"	12" square columns; gravel aggregate concrete (2647 psi); Reinforcement: vertical, four 5/8" rebars; horizontal, 5/16" ties at 4 1/2" pitch; Cover: 2".	78.2 tons	38 min.		1	7	1	1/2
C-12-RC-2	12"	Reinforced columns with 1 1/2" concrete outside of reinforced steel; Gross diameter or side of column: 12"; Group I, Column A.	—	6 hrs.		1		2, 3	6
C-12-RC-3	12"	Description as per C-12-RC-2; Group I, Column B.	—	4 hrs.		1		2, 3	4
C-12-RC-4	12"	Description as per C-12-RC-2; Group II, Column A.	—	4 hrs.		1		2, 3	4
C-12-RC-5	12"	Description as per C-12-RC-2; Group II, Column B.	—	2 hrs. 30 min.		1		2, 3	2 1/2
C-12-RC-6	12"	Description as per C-12-RC-2; Group III, Column A.	—	3 hrs.		1		2, 3	3
C-12-RC-7	12"	Description as per C-12-RC-2; Group III, Column B.	—	2 hrs.		1		2, 3	2
C-12-RC-8	12"	Description as per C-12-RC-2; Group IV, Column A.	—	2 hrs.		1		2, 3	2
C-12-RC-9	12"	Description as per C-12-RC-2; Group IV, Column B.	—	1 hr. 30 min.		1		2, 3	1 1/2

For SI: 1 inch = 25.4 mm, 1 pound per square inch = 0.00689 MPa, 1 pound per square yard = 5.3 N/m².

Notes:

1. Failure mode—unspecified structural.
2. Group I: includes concrete having calcareous aggregate containing a combined total of not more than 10 percent of quartz, chert and flint for the coarse aggregate.
Group II: includes concrete having trap-rock aggregate applied without metal ties and also concrete having cinder, sandstone or granite aggregate, if held in place with wire mesh or expanded metal having not larger than 4-inch mesh, weighing not less than 1.7 lbs./yd.², placed not more than 1 inch from the surface of the concrete.
Group III: includes concrete having cinder, sandstone or granite aggregate tied with No. 5 gage steel wire, wound spirally over the column section on a pitch of 8 inches, or equivalent ties, and concrete having siliceous aggregates containing a combined total of 60 percent or more of quartz, chert and flint, if held in place with wire mesh or expanded metal having not larger than 4-inch mesh, weighing not less than 1.7 lbs./yd.², placed not more than 1 inch from the surface of the concrete.
Group IV: includes concrete having siliceous aggregates containing a combined total of 60 percent or more of quartz, chert and flint, and tied with No. 5 gage steel wire wound spirally over the column section on a pitch of 8 inches, or equivalent ties.
3. Groupings of aggregates and ties are the same as for structural steel columns protected solidly with concrete, the ties to be placed over the vertical reinforcing bars and the mesh where required, to be placed within 1 inch from the surface of the column.
Column A: working loads are assumed as carried by the area of the column inside of the lines circumscribing the reinforcing steel.
Column B: working loads are assumed as carried by the gross area of the column.

**TABLE 2.1.4
REINFORCED CONCRETE COLUMNS
MINIMUM DIMENSION 14" TO LESS THAN 16"**

ITEM CODE	MINIMUM DIMENSION	CONSTRUCTION DETAILS	PERFORMANCE		REFERENCE NUMBER			NOTES	REC. HOURS
			LOAD	TIME	PRE- BMS-92	BMS-92	POST- BMS-92		
C-14-RC-1	14"	14" square columns; gravel aggregate concrete (4295 psi); Reinforcement: vertical four 3/4" rebars; horizontal: 1/4" ties at 9" pitch; Cover: 1 1/2"	86 tons	1 hr. 22 min.			7	1	1 1/4
C-14-RC-2	14"	Reinforced concrete columns with 1 1/2" concrete outside reinforcing steel; Gross diameter or side of column: 12" ; Group I, Column A.	—	7 hrs.		1		2, 3	7
C-14-RC-3	14"	Description as per C-14-RC-2; Group II, Column B.	—	5 hrs.		1		2, 3	5
C-14-RC-4	14"	Description as per C-14-RC-2; Group III, Column A.	—	5 hrs.		1		2, 3	5
C-14-RC-5	14"	Description as per C-14-RC-2; Group IV, Column B.	—	3 hrs. 30 min.		1		2, 3	3 1/2
C-14-RC-6	14"	Description as per C-14-RC-2; Group III, Column A.	—	4 hrs.		1		2, 3	4
C-14-RC-7	14"	Description as per C-14-RC-2; Group III, Column B.	—	2 hrs. 30 min.		1		2, 3	2 1/2
C-14-RC-8	14"	Description as per C-14-RC-2; Group IV, Column A.	—	2 hrs. 30 min.		1		2, 3	2 1/2
C-14-RC-9	14"	Description as per C-14-RC-2; Group IV, Column B.	—	1 hr. 30 min.		1		2, 3	1 1/2

For SI: 1 inch = 25.4 mm, 1 pound per square inch = 0.00689 MPa, 1 pound per square yard = 5.3 N/m².

Notes:

1. Failure mode—main rebars buckled between links at various points.
2. Group I: includes concrete having calcareous aggregate containing a combined total of not more than 10 percent of quartz, chert and flint for the coarse aggregate.
Group II: includes concrete having trap-rock aggregate applied without metal ties and also concrete having cinder, sandstone or granite aggregate, if held in place with wire mesh or expanded metal having not larger than 4-inch mesh, weighing not less than 1.7 lbs./yd.², placed not more than 1 inch from the surface of the concrete.
Group III: includes concrete having cinder, sandstone or granite aggregate tied with No. 5 gage steel wire, wound spirally over the column section on a pitch of 8 inches, or equivalent ties, and concrete having siliceous aggregates containing a combined total of 60 percent or more of quartz, chert and flint, if held in place with wire mesh or expanded metal having not larger than 4-inch mesh, weighing not less than 1.7 lbs./yd.², placed not more than 1 inch from the surface of the concrete.
Group IV: includes concrete having siliceous aggregates containing a combined total of 60 percent or more of quartz, chert and flint, and tied with No. 5 gage steel wire wound spirally over the column section on a pitch of 8 inches, or equivalent ties.
3. Groupings of aggregates and ties are the same as for structural steel columns protected solidly with concrete, the ties to be placed over the vertical reinforcing bars and the mesh where required, to be placed within 1 inch from the surface of the column.
Column A: working loads are assumed as carried by the area of the column inside of the lines circumscribing the reinforcing steel.
Column B: working loads are assumed as carried by the gross area of the column.

**FIGURE 2.1.5
REINFORCED CONCRETE COLUMNS
MINIMUM DIMENSION 16" TO LESS THAN 18"**

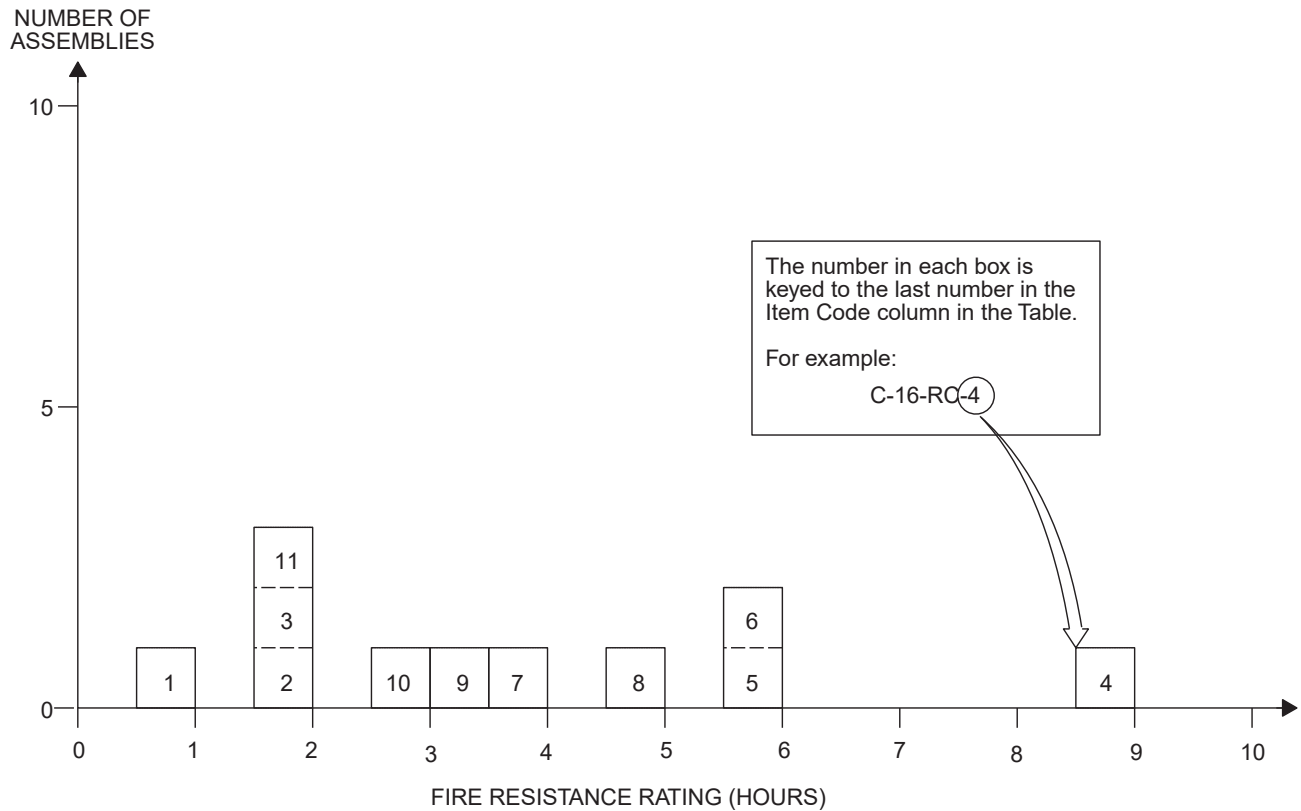

**TABLE 2.1.5
REINFORCED CONCRETE COLUMNS
MINIMUM DIMENSION 16" TO LESS THAN 18"**

ITEM CODE	MINIMUM DIMENSION	CONSTRUCTION DETAILS	PERFORMANCE		REFERENCE NUMBER			NOTES	REC. HOURS
			LOAD	TIME	PRE-BMS-92	BMS-92	POST-BMS-92		
C-16-RC-1	16"	16" square columns; gravel aggregate concrete (4550 psi); Reinforcement: vertical, eight 1 ³ / ₈ " rebar; horizontal, 5/16" ties at 6" pitch 1 ³ / ₈ " below column surface and 5/16" ties at 6" pitch linking center rebar of each face forming a smaller square in column cross section.	237 tons	1 hr			7	1, 2, 3	1
C-16-RC-2	16"	16" square columns; gravel aggregate concrete (3360 psi); Reinforcement: vertical, eight 1 ³ / ₈ " rebar; horizontal, 5/16" ties at 6" pitch; Cover: 1 ³ / ₈ ".	210 tons	2 hrs.			7	2, 4, 5, 6	2
C-16-RC-3	16"	16" square columns; gravel aggregate concrete (3980 psi); Reinforcement: vertical, four 7/8" rebar; horizontal, 3/8" ties at 6" pitch; Cover: 1".	123.5 tons	2 hrs.			7	2, 4, 7	2
C-16-RC-4	16"	Reinforced concrete columns with 1 ¹ / ₂ " concrete outside reinforcing steel; Gross diameter or side of column: 16"; Group I, Column A.	—	9 hrs.		1		8, 9	9
C-16-RC-5	16"	Description as per C-16-RC-4; Group I, Column B.	—	6 hrs.		1		8, 9	6
C-16-RC-6	16"	Description as per C-16-RC-4; Group II, Column A.	—	6 hrs.		1		8, 9	6

(continued)

**TABLE 2.1.5—continued
REINFORCED CONCRETE COLUMNS
MINIMUM DIMENSION 16" TO LESS THAN 18**

ITEM CODE	MINIMUM DIMENSION	CONSTRUCTION DETAILS	PERFORMANCE		REFERENCE NUMBER			NOTES	REC. HOURS
			LOAD	TIME	PRE-BMS-92	BMS-92	POST-BMS-92		
C-16-RC-7	16"	Description as per C-16-RC-4; Group II, Column B.	—	4 hrs.		1		8, 9	4
C-16-RC-8	16"	Description as per C-16-RC-4; Group III, Column A.	—	5 hrs.		1		8, 9	5
C-16-RC-9	16"	Description as per C-16-RC-4; Group III, Column B.	—	3 hrs. 30 min.		1		8, 9	3½
C-16-RC-10	16"	Description as per C-16-RC-4; Group IV, Column A.	—	3 hrs.		1		8, 9	3
C-16-RC-11	16"	Description as per C-16-RC-4; Group IV, Column B.	—	2 hrs.		1		8, 9	2

For SI: 1 inch = 25.4 mm, 1 pound per square inch = 0.00689 MPa, 1 pound per square yard = 5.3 N/m².

Notes:

1. Column passed 1-hour fire test.
2. Column passed hose stream test.
3. No reload specified.
4. Column passed 2-hour fire test.
5. Column reloaded successfully after 24 hours.
6. Reinforcing details same as C-16-RC-1.
7. Column passed reload after 72 hours.
8. Group I: includes concrete having calcareous aggregate containing a combined total of not more than 10 percent of quartz, chert and flint for the coarse aggregate.
Group II: includes concrete having trap-rock aggregate applied without metal ties and also concrete having cinder, sandstone or granite aggregate, if held in place with wire mesh or expanded metal having not larger than 4-inch mesh, weighing not less than 1.7 lbs./yd.², placed not more than 1 inch from the surface of the concrete.
Group III: includes concrete having cinder, sandstone or granite aggregate tied with No. 5 gage steel wire, wound spirally over the column section on a pitch of 8 inches, or equivalent ties, and concrete having siliceous aggregates containing a combined total of 60 percent or more of quartz, chert and flint, if held in place with wire mesh or expanded metal having not larger than 4-inch mesh, weighing not less than 1.7 lbs./yd.², placed not more than 1 inch from the surface of the concrete.
Group IV: includes concrete having siliceous aggregates containing a combined total of 60 percent or more of quartz, chert and flint, and tied with No. 5 gage steel wire wound spirally over the column section on a pitch of 8 inches, or equivalent ties.
9. Groupings of aggregates and ties are the same as for structural steel columns protected solidly with concrete, the ties to be placed over the vertical reinforcing bars and the mesh where required, to be placed within 1 inch from the surface of the column.
Column A: working loads are assumed as carried by the area of the column inside of the lines circumscribing the reinforcing steel.
Column B: working loads are assumed as carried by the gross area of the column.

**TABLE 2.1.6
REINFORCED CONCRETE COLUMNS
MINIMUM DIMENSION 18" TO LESS THAN 20"**

ITEM CODE	MINIMUM DIMENSION	CONSTRUCTION DETAILS	PERFORMANCE		REFERENCE NUMBER			NOTES	REC. HOURS
			LOAD	TIME	PRE- BMS-92	BMS-92	POST- BMS-92		
C-18-RC-1	18"	Reinforced concrete columns with 1½" concrete outside reinforced steel; Gross diameter or side of column: 18" ; Group I, Column A.	—	11 hrs.		1		1, 2	11
C-18-RC-2	18"	Description as per C-18-RC-1; Group I, Column B.	—	8 hrs.		1		1, 2	8
C-18-RC-3	18"	Description as per C-18-RC-1; Group II, Column A.	—	7 hrs.		1		1, 2	7
C-18-RC-4	18"	Description as per C-18-RC-1; Group II, Column B.	—	5 hrs.		1		1, 2	5
C-18-RC-5	18"	Description as per C-18-RC-1; Group III, Column A.	—	6 hrs.		1		1, 2	6
C-18-RC-6	18"	Description as per C-18-RC-1; Group III, Column B.	—	4 hrs.		1		1, 2	4
C-18-RC-7	18"	Description as per C-18-RC-1; Group IV, Column A.	—	3 hrs. 30 min.		1		1, 2	3½
C-18-RC-8	18"	Description as per C-18-RC-1; Group IV, Column B.	—	2 hrs. 30 min.		1		1, 2	2½

For SI: 1 inch = 25.4 mm, 1 pound per square yard = 5.3 N/m².

Notes:

- Group I: includes concrete having calcareous aggregate containing a combined total of not more than 10 percent of quartz, chert and flint for the coarse aggregate.
Group II: includes concrete having trap-rock aggregate applied without metal ties and also concrete having cinder, sandstone or granite aggregate, if held in place with wire mesh or expanded metal having not larger than 4-inch mesh, weighing not less than 1.7 lbs./yd.², placed not more than 1 inch from the surface of the concrete.
Group III: includes concrete having cinder, sandstone or granite aggregate tied with No. 5 gage steel wire, wound spirally over the column section on a pitch of 8 inches, or equivalent ties, and concrete having siliceous aggregates containing a combined total of 60 percent or more of quartz, chert and flint, if held in place with wire mesh or expanded metal having not larger than 4-inch mesh, weighing not less than 1.7 lbs./yd.², placed not more than 1 inch from the surface of the concrete.
Group IV: includes concrete having siliceous aggregates containing a combined total of 60 percent or more of quartz, chert and flint and, tied with No. 5 gage steel wire wound spirally over the column section on a pitch of 8 inches, or equivalent ties.
- Groupings of aggregates and ties are the same as for structural steel columns protected solidly with concrete, the ties to be placed over the vertical reinforcing bars and the mesh where required, to be placed within 1 inch from the surface of the column.
Column A: working loads are assumed as carried by the area of the column inside of the lines circumscribing the reinforcing steel.
Column B: working loads are assumed as carried by the gross area of the column.

**FIGURE 2.1.7
REINFORCED CONCRETE COLUMNS
MINIMUM DIMENSION 20" TO LESS THAN 22"**

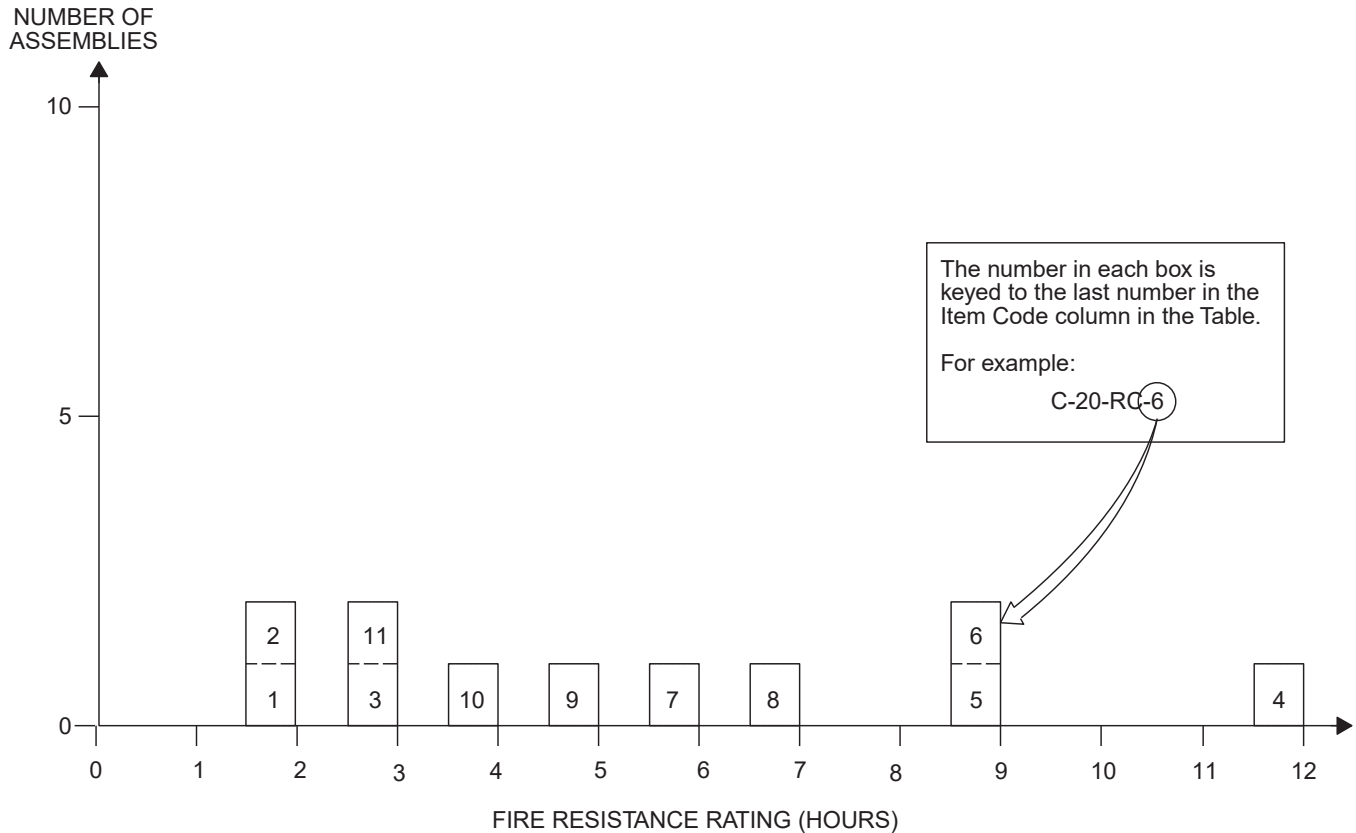

**TABLE 2.1.7
REINFORCED CONCRETE COLUMNS
MINIMUM DIMENSION 20" TO LESS THAN 22"**

ITEM CODE	MINIMUM DIMENSION	CONSTRUCTION DETAILS	PERFORMANCE		REFERENCE NUMBER			NOTES	REC. HOURS
			LOAD	TIME	PRE-BMS-92	BMS-92	POST-BMS-92		
C-20-RC-1	20"	20" square columns; gravel aggregate concrete (6690 psi); Reinforcement: vertical, four 1 ³ / ₄ " rebar; horizontal, 3 ³ / ₈ " wire at 6" pitch; Cover 1 ³ / ₄ ".	367 tons	2 hrs.			7	1, 2, 3	2
C-20-RC-2	20"	20" square columns; gravel aggregate concrete (4330 psi); Reinforcement: vertical, four 1 ³ / ₄ " rebar; horizontal, 3 ³ / ₈ " ties at 6" pitch; Cover 1 ³ / ₄ ".	327 tons	2 hrs.			7	1, 2, 4	2
C-20-RC-3	20 ¹ / ₄ "	20" square columns; gravel aggregate concrete (4230 psi); Reinforcement: vertical, four 1 ¹ / ₈ " rebar; horizontal, 3 ³ / ₈ " wire at 5" pitch; Cover 1 ¹ / ₈ ".	199 tons	2 hrs. 56 min.			7	5	2 ³ / ₄
C-20-RC-4	20"	Reinforced concrete columns with 1 ¹ / ₂ " concrete outside of reinforcing steel; Gross diameter or side of column: 20" ; Group I, Column A.	—	12 hrs.		1		6, 7	12
C-20-RC-5	20"	Description as per C-20-RC-4; Group I, Column B.	—	9 hrs.		1		6, 7	9

(continued)

**TABLE 2.1.7—continued
REINFORCED CONCRETE COLUMNS
MINIMUM DIMENSION 20" TO LESS THAN 22"**

ITEM CODE	MINIMUM DIMENSION	CONSTRUCTION DETAILS	PERFORMANCE		REFERENCE NUMBER			NOTES	REC. HOURS
			LOAD	TIME	PRE-BMS-92	BMS-92	POST-BMS-92		
C-20-RC-6	20"	Description as per C-20-RC-4; Group II, Column A.	—	9 hrs.		1		6, 7	9
C-20-RC-7	20"	Description as per C-20-RC-4; Group II, Column B.	—	6 hrs		1		6, 7	6
C-20-RC-8	20"	Description as per C-20-RC-4; Group III, Column A.	—	7 hrs.		1		6, 7	7
C-20-RC-9	20"	Description as per C-20-RC-4; Group III, Column B.	—	5 hrs.		1		6, 7	5
C-20-RC-10	20"	Description as per C-20-RC-4; Group IV, Column A.	—	4 hrs.		1		6, 7	4
C-20-RC-11	20"	Description as per C-20-RC-4; Group IV, Column B.	—	3 hrs.		1		6, 7	3

For SI: 1 inch = 25.4 mm, 1 pound per square yard = 5.3 N/m², 1 ton = 8.896 kN.

Notes:

1. Passed 2-hour fire test.
2. Passed hose stream test.
3. Failed during reload at 300 tons.
4. Passed reload after 72 hours.
5. Failure mode—collapse.
6. Group I: includes concrete having calcareous aggregate containing a combined total of not more than 10 percent of quartz, chert and flint for the coarse aggregate.
Group II: includes concrete having trap-rock aggregate applied without metal ties and also concrete having cinder, sandstone or granite aggregate, if held in place with wire mesh or expanded metal having not larger than 4-inch mesh, weighing not less than 1.7 lbs./yd.², placed not more than 1 inch from the surface of the concrete.
Group III: includes concrete having cinder, sandstone or granite aggregate tied with No. 5 gage steel wire, wound spirally over the column section on a pitch of 8 inches, or equivalent ties, and concrete having siliceous aggregates containing a combined total of 60 percent or more of quartz, chert and flint, if held in place with wire mesh or expanded metal having not larger than 4-inch mesh, weighing not less than 1.7 lbs./yd.², placed not more than 1 inch from the surface of the concrete.
Group IV: includes concrete having siliceous aggregates containing a combined total of 60 percent or more of quartz, chert and flint, and tied with No. 5 gage steel wire wound spirally over the column section on a pitch of 8 inches, or equivalent ties.
7. Groupings of aggregates and ties are the same as for structural steel columns protected solidly with concrete, the ties to be placed over the vertical reinforcing bars and the mesh where required, to be placed within 1 inch from the surface of the column.
Column A: working loads are assumed as carried by the area of the column inside of the lines circumscribing the reinforcing steel.
Column B: working loads are assumed as carried by the gross area of the column.

**TABLE 2.1.8
HEXAGONAL REINFORCED CONCRETE COLUMNS
MINIMUM DIMENSION 12" TO LESS THAN 14"**

ITEM CODE	MINIMUM DIMENSION	CONSTRUCTION DETAILS	PERFORMANCE		REFERENCE NUMBER			NOTES	REC. HOURS
			LOAD	TIME	PRE-BMS-92	BMS-92	POST-BMS-92		
C-12-HRC-1	12"	12" hexagonal columns; gravel aggregate concrete (4420 psi); Reinforcement: vertical, eight 1/2" rebars; horizontal, 5/16" helical winding at 1 1/2" pitch; Cover: 1/2".	88 tons	58 min.			7	1	3/4
C-12-HRC-2	12"	12" hexagonal columns; gravel aggregate concrete (3460 psi); Reinforcement: vertical, eight 1/2" rebars; horizontal, 5/16" helical winding at 1 1/2" pitch; Cover: 1/2".	78.7 tons	1 hr.			7	2	1

For SI: 1 inch = 25.4 mm, 1 pound per square inch = 0.00689 MPa, 1 ton = 8.896 kN.

Notes:

1. Failure mode—collapse.
2. Test stopped at 1 hour.

RESOURCE A

**TABLE 2.1.9
HEXAGONAL REINFORCED CONCRETE COLUMNS
MINIMUM DIMENSION 14" TO LESS THAN 16"**

ITEM CODE	MINIMUM DIMENSION	CONSTRUCTION DETAILS	PERFORMANCE		REFERENCE NUMBER			NOTES	REC. HOURS
			LOAD	TIME	PRE-BMS-92	BMS-92	POST-BMS-92		
C-14-HRC-1	14"	14" hexagonal columns; gravel aggregate concrete (4970 psi); Reinforcement: vertical, eight 1/2" rebars; horizontal, 5/16" helical winding on 2" pitch; Cover: 1/2".	90 tons	2 hrs.			7	1, 2, 3	2

For SI: 1 inch = 25.4 mm, 1 pound per square inch = 0.00689 MPa, 1 ton = 8.896 kN.

Notes:

1. Withstood 2-hour fire test.
2. Withstood hose stream test.
3. Withstood reload after 48 hours.

**TABLE 2.1.10
HEXAGONAL REINFORCED CONCRETE COLUMNS
DIAMETER—16" TO LESS THAN 18"**

ITEM CODE	MINIMUM DIMENSION	CONSTRUCTION DETAILS	PERFORMANCE		REFERENCE NUMBER			NOTES	REC. HOURS
			LOAD	TIME	PRE-BMS-92	BMS-92	POST-BMS-92		
C-16-HRC-1	16"	16" hexagonal columns; gravel concrete (6320 psi); Reinforcement: vertical, eight 5/8" rebars; horizontal, 5/16" helical winding on 3/4" pitch; Cover: 1/2".	140 tons	1 hr. 55 min.			7	1	1 3/4
C-16-HRC-2	16"	16" hexagonal columns; gravel aggregate concrete (5580 psi); Reinforcement: vertical, eight 5/8" rebars; horizontal, 5/16" helical winding on 1 3/4" pitch; Cover: 1/2".	124 tons	2 hrs.			7	2	2

For SI: 1 inch = 25.4 mm, 1 pound per square inch = 0.00689 MPa, 1 ton = 8.896 kN.

Notes:

1. Failure mode—collapse.
2. Failed on furnace removal.

**TABLE 2.1.11
HEXAGONAL REINFORCED CONCRETE COLUMNS
DIAMETER—20" TO LESS THAN 22"**

ITEM CODE	MINIMUM DIMENSION	CONSTRUCTION DETAILS	PERFORMANCE		REFERENCE NUMBER			NOTES	REC. HOURS
			LOAD	TIME	PRE-BMS-92	BMS-92	POST-BMS-92		
C-20-HRC-1	20"	20" hexagonal columns; gravel concrete (6080 psi); Reinforcement: vertical, 3/4" rebars; horizontal, 5/6" helical winding on 1 3/4" pitch; Cover: 1/2".	211 tons	2 hrs.			7	1	2
C-20-HRC-2	20"	20" hexagonal columns; gravel concrete (5080 psi); Reinforcement: vertical, 3/4" rebars; horizontal, 5/16" wire on 1 3/4" pitch; Cover: 1/2".	184 tons	2 hrs. 15 min.			7	2, 3, 4	2 1/4

For SI: 1 inch = 25.4 mm, 1 pound per square inch = 0.00689 MPa, 1 ton = 8.896 kN.

Notes:

1. Column collapsed on furnace removal.
2. Passed 2 1/4-hour fire test.
3. Passed hose stream test.
4. Withstood reload after 48 hours.

**TABLE 2.2
ROUND CAST IRON COLUMNS**

ITEM CODE	MINIMUM DIMENSION	CONSTRUCTION DETAILS	PERFORMANCE		REFERENCE NUMBER			NOTES	REC. HOURS
			LOAD	TIME	PRE-BMS-92	BMS-92	POST-BMS-92		
C-7-CI-1	7" O.D.	Column: 0.6" minimum metal thickness; unprotected.	—	30 min.		1			1/2
C-7-CI-2	7" O.D.	Column: 0.6" minimum metal thickness concrete filled, outside unprotected.	—	45 min.		1			3/4
C-11-CI-3	11" O.D.	Column: 0.6" minimum metal thickness; Protection: 1 1/2" portland cement plaster on high ribbed metal lath, 1/2" broken air space.	—	3 hrs.		1			3
C-11-CI-4	11" O.D.	Column: 0.6" minimum metal thickness; Protection: 2" concrete other than siliceous aggregate.	—	2 hrs. 30 min.		1			2 1/2
C-12-CI-5	12.5" O.D.	Column: 7" O.D. 0.6" minimum metal thickness; Protection: 2" porous hollow tile, 3/4" mortar between tile and column, outside wire ties.	—	3 hrs.		1			3
C-7-CI-6	7.6" O.D.	Column: 7" I.D., 3/10" minimum metal thickness, concrete filled unprotected.	—	30 min.		1			1/2
C-8-CI-7	8.6" O.D.	Column: 8" I.D., 3/10" minimum metal thickness; concrete filled reinforced with four 3 1/2" x 3/8" angles, in fill; unprotected outside.	—	1 hr.		1			1

For SI: 1 inch = 25.4 mm.

**FIGURE 2.3
STEEL COLUMNS-GYPSUM ENCASEMENTS**

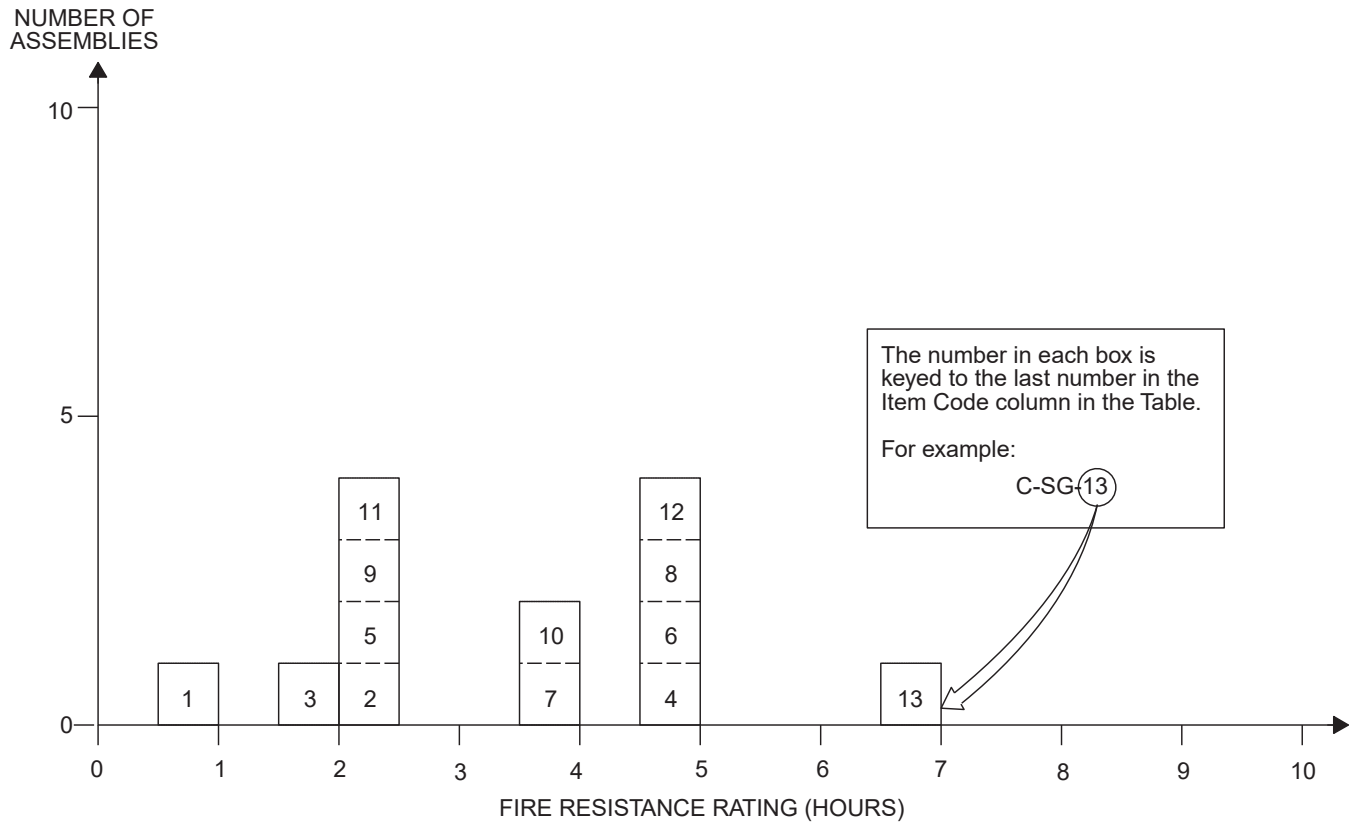

**TABLE 2.3
STEEL COLUMNS—GYPSUM ENCASEMENTS**

ITEM CODE	MINIMUM AREA OF SOLID MATERIAL	CONSTRUCTION DETAILS	PERFORMANCE		REFERENCE NUMBER			NOTES	REC. HOURS
			LOAD	TIME	PRE-BMS-92	BMS-92	POST-BMS-92		
C-SG-1	—	Steel protected with 3/4" 1:3 sanded gypsum or 1" 1:2 1/2 portland cement plaster on wire or lath; one layer.	—	1 hr.		1			1
C-SG-2	—	Same as C-SG-1; two layers.	—	2 hrs. 30 min.		1			2 1/2
C-SG-3	130 in. ²	2" solid blocks with wire mesh in horizontal joints; 1" mortar on flange; reentrant space filled with block and mortar.	—	2 hrs.		1			2
C-SG-4	150 in. ²	Same as C-130-SG-3 with 1/2" sanded gypsum plaster.	—	5 hrs.		1			5
C-SG-5	130 in. ²	2" solid blocks with wire mesh in horizontal joints; 1" mortar on flange; reentrant space filled with gypsum concrete.	—	2 hrs. 30 min.		1			2 1/2
C-SG-6	150 in. ²	Same as C-130-SG-5 with 1/2" sanded gypsum plaster.	—	5 hrs.		1			5
C-SG-7	300 in. ²	4" solid blocks with wire mesh in horizontal joints; 1" mortar on flange; reentrant space filled with block and mortar.	—	4 hrs.		1			4

(continued)

**TABLE 2.3—continued
STEEL COLUMNS—GYPSUM ENCASEMENTS**

ITEM CODE	MINIMUM AREA OF SOLID MATERIAL	CONSTRUCTION DETAILS	PERFORMANCE		REFERENCE NUMBER			NOTES	REC. HOURS
			LOAD	TIME	PRE-BMS-92	BMS-92	POST-BMS-92		
C-SG-8	300 in. ²	Same as C-300-SG-7 with reentrant space filled with gypsum concrete.	—	5 hrs.		1			5
C-SG-9	85 in. ²	2" solid blocks with cramps at horizontal joints; mortar on flange only at horizontal joints; reentrant space not filled.	—	2 hrs. 30 min.		1			2½
C-SG-10	105 in. ²	Same as C-85-SG-9 with ½" sanded gypsum plaster.	—	4 hrs.		1			4
C-SG-11	95 in. ²	3" hollow blocks with cramps at horizontal joints; mortar on flange only at horizontal joints; reentrant space not filled.	—	2 hrs. 30 min.		1			2½
C-SG-12	120 in. ²	Same as C-95-SG-11 with ½" sanded gypsum plaster.	—	5 hrs.		1			5
C-SG-13	130 in. ²	2" neat fibered gypsum reentrant space filled poured solid and reinforced with 4" × 4" wire mesh ½" sanded gypsum plaster.	—	7 hrs.		1			7

For SI: 1 inch = 25.4 mm, 1 square inch = 645 mm².

**TABLE 2.4
TIMBER COLUMNS MINIMUM DIMENSION**

ITEM CODE	MINIMUM DIMENSION	CONSTRUCTION DETAILS	PERFORMANCE		REFERENCE NUMBER			NOTES	REC. HOURS
			LOAD	TIME	PRE-BMS-92	BMS-92	POST-BMS-92		
C-11-TC-1	11"	With unprotected steel plate cap.	—	30 min.		1		1, 2	½
C-11-TC-2	11"	With unprotected cast iron cap and pintle.	—	45 min.		1		1, 2	¾
C-11-TC-3	11"	With concrete or protected steel or cast iron cap.	—	1 hr. 15 min.		1		1, 2	¼
C-11-TC-4	11"	With ⅜" gypsum wallboard over column and over cast iron or steel cap.	—	1 hr. 15 min.		1		1, 2	¼
C-11-TC-5	11"	With 1" portland cement plaster on wire lath over column and over cast iron or steel cap; ¾" air space.	—	2 hrs.		1		1, 2	2

For SI: 1 inch = 25.4 mm, 1 square inch = 645 mm².

Notes:

1. Minimum area: 120 square inches.
2. Type of wood: long leaf pine or Douglas fir.

**TABLE 2.5.1.1
STEEL COLUMNS—CONCRETE ENCASEMENTS
MINIMUM DIMENSION LESS THAN 6"**

ITEM CODE	MINIMUM DIMENSION	CONSTRUCTION DETAILS	PERFORMANCE		REFERENCE NUMBER			NOTES	REC. HOURS
			LOAD	TIME	PRE-BMS-92	BMS-92	POST-BMS-92		
C-5-SC-1	5"	5" × 6" outer dimensions; 4" × 3" × 10 lbs. "H" beam; Protection: gravel concrete (4900 psi) 6" × 4" - 13 SWG mesh.	12 tons	1 hr. 29 min.			7	1	¼

For SI: 1 inch = 25.4 mm, 1 pound per square inch = 0.00689 MPa, 1 ton = 8.896 kN.

Notes:

1. Failure mode—collapse.

RESOURCE A

**TABLE 2.5.1.2
STEEL COLUMNS—CONCRETE ENCASEMENTS
6" TO LESS THAN 8" THICK**

ITEM CODE	MINIMUM DIMENSION	CONSTRUCTION DETAILS	PERFORMANCE		REFERENCE NUMBER			NOTES	REC. HOURS
			LOAD	TIME	PRE-BMS-92	BMS-92	POST-BMS-92		
C-7-SC-1	7"	7" × 8" column; 4" × 3" × 10 lbs. "H" beam; Protection: brick filled concrete (6220 psi); 6" × 4" mesh - 13 SWG; 1" below column surface.	12 tons	2 hrs. 46 min.			7	1	2 ³ / ₄
C-7-SC-2	7"	7" × 8" column; 4" × 3" × 10 lbs. "H" beam; Protection: gravel concrete (5140 psi); 6" × 4" 13 SWG mesh 1" below surface.	12 tons	3 hrs. 1 min.			7	1	3
C-7-SC-3	7"	7" × 8" column; 4" × 3" × 10 lbs. "H" beam; Protection: concrete (4540 psi); 6" × 4" - 13 SWG mesh; 1" below column surface.	12 tons	3 hrs. 9 min.			7	1	3
C-7-SC-4	7"	7" × 8" column; 4" × 3" × 10 lbs. "H" beam; Protection: gravel concrete (5520 psi); 4" × 4" mesh; 16 SWG.	12 tons	2 hrs. 50 min.			7	1	2 ³ / ₄

For SI: 1 inch = 25.4 mm, 1 pound per square inch = 0.00689 MPa, 1 ton = 8.896 kN.

Notes:

1. Failure mode—collapse.

**FIGURE 2.5.1.3
STEEL COLUMNS—CONCRETE ENCASEMENTS
MINIMUM DIMENSION 8" TO LESS THAN 10"**

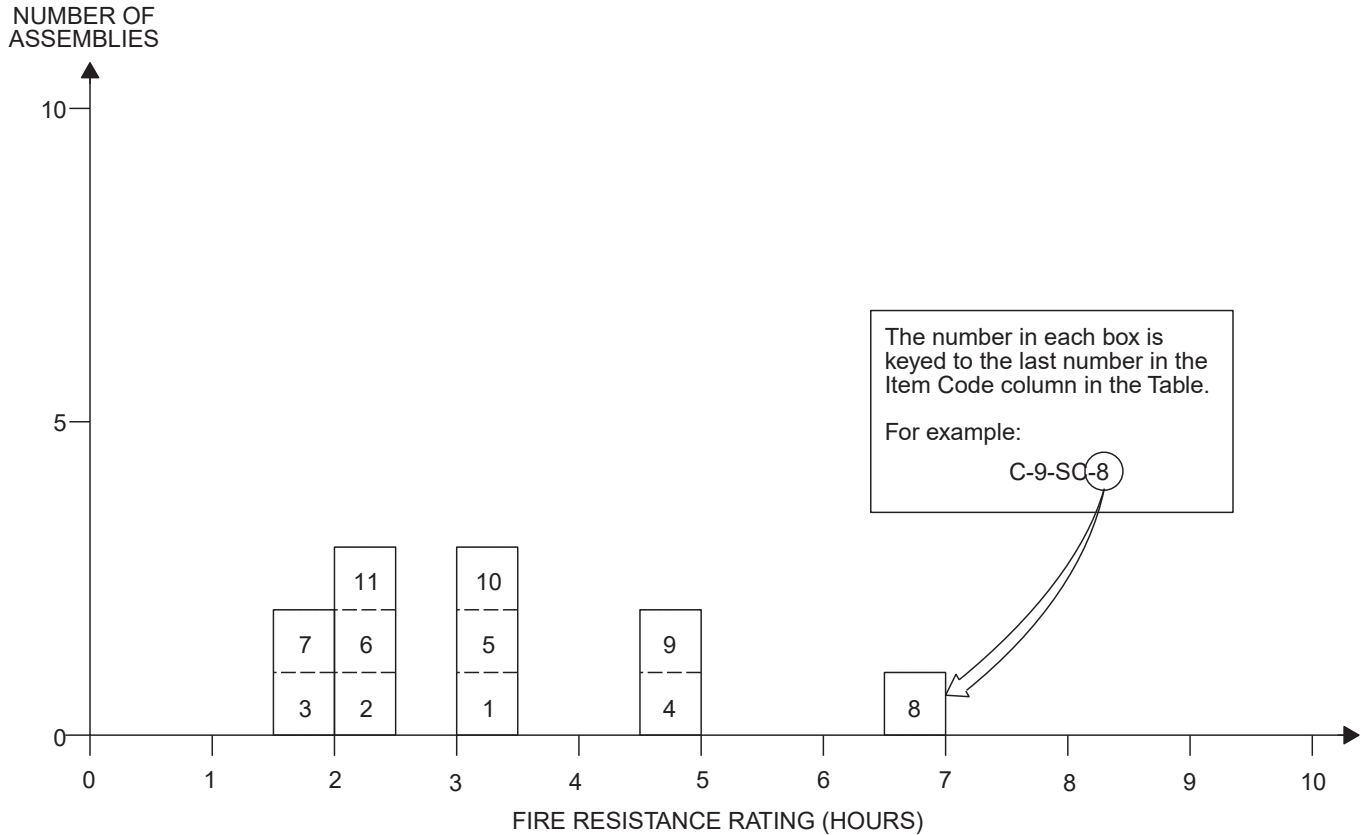

**TABLE 2.5.1.3
STEEL COLUMNS—CONCRETE ENCASEMENTS
MINIMUM DIMENSION 8" TO LESS THAN 10"**

ITEM CODE	MINIMUM DIMENSION	CONSTRUCTION DETAILS	PERFORMANCE		REFERENCE NUMBER			NOTES	REC. HOURS
			LOAD	TIME	PRE-BMS-92	BMS-92	POST-BMS-92		
C-8-SC-1	8½"	8½" × 10" column; 6" × 4½" × 20 lbs. "H" beam; Protection: gravel concrete (5140 psi); 6" × 4" - 13 SWG mesh.	39 tons	3 hrs. 8 min.			7	1	3
C-8-SC-2	8"	8" × 10" column; 8" × 6" × 35 lbs. "I" beam; Protection: gravel concrete (4240 psi); 6" × 4" - 13 SWG mesh; ½" cover.	90 tons	2 hrs. 1 min.			7	1	2
C-8-SC-3	8"	8" × 10" concrete encased column; 8" × 6" × 35 lbs. "H" beam; protection: aggregate concrete (3750 psi); 4" mesh - 16 SWG reinforcing ½" below column surface.	90 tons	1 hr. 58 min.			7	1	1¾
C-8-SC-4	8"	6" × 6" steel column; 2" outside protection; Group I.	—	5 hrs.		1		2	5
C-8-SC-5	8"	6" × 6" steel column; 2" outside protection; Group II.	—	3 hrs. 30 min.		1		2	3½
C-8-SC-6	8"	6" × 6" steel column; 2" outside protection; Group III.	—	2 hrs. 30 min.		1		2	2½

(continued)

TABLE 2.5.1.3—continued
STEEL COLUMNS—CONCRETE ENCASEMENTS
MINIMUM DIMENSION 8" TO LESS THAN 10"

ITEM CODE	MINIMUM DIMENSION	CONSTRUCTION DETAILS	PERFORMANCE		REFERENCE NUMBER			NOTES	REC. HOURS
			LOAD	TIME	PRE-BMS-92	BMS-92	POST-BMS-92		
C-8-SC-7	8"	6" × 6" steel column; 2" outside protection; Group IV.	—	1 hr. 45 min.		1		2	1 ³ / ₄
C-9-SC-8	9"	6" × 6" steel column; 3" outside protection; Group I.	—	7 hrs.		1		2	7
C-9-SC-9	9"	6" × 6" steel column; 3" outside protection; Group II.	—	5 hrs.		1		2	5
C-9-SC-10	9"	6" × 6" steel column; 3" outside protection; Group III.	—	3 hrs. 30 min.		1		2	3 ¹ / ₂
C-9-SC-11	9"	6" × 6" steel column; 3" outside protection; Group IV.	—	2 hrs. 30 min.		1		2	2 ¹ / ₂

For SI: 1 inch = 25.4 mm, 1 pound = 0.004448 kN, 1 pound per square inch = 0.00689 MPa, 1 pound per square yard = 5.3 N/m², 1 ton = 8.896 kN.

Notes:

1. Failure mode—collapse.
2. Group I: includes concrete having calcareous aggregate containing a combined total of not more than 10 percent of quartz, chert and flint for the coarse aggregate.
 Group II: includes concrete having trap-rock aggregate applied without metal ties and also concrete having cinder, sandstone or granite aggregate, if held in place with wire mesh or expanded metal having not larger than 4-inch mesh, weighing not less than 1.7 lbs./yd.², placed not more than 1 inch from the surface of the concrete.
 Group III: includes concrete having cinder, sandstone or granite aggregate tied with No. 5 gage steel wire, wound spirally over the column section on a pitch of 8 inches, or equivalent ties, and concrete having siliceous aggregates containing a combined total of 60 percent or more of quartz, chert and flint, if held in place with wire mesh or expanded metal having not larger than 4-inch mesh, weighing not less than 1.7 lbs./yd.², placed not more than 1 inch from the surface of the concrete.
 Group IV: includes concrete having siliceous aggregates containing a combined total of 60 percent or more of quartz, chert and flint, and tied with No. 5 gage steel wire wound spirally over the column section on a pitch of 8 inches, or equivalent ties.

FIGURE 2.5.1.4
STEEL COLUMNS—CONCRETE ENCASEMENTS
MINIMUM DIMENSION 10" TO LESS THAN 12"

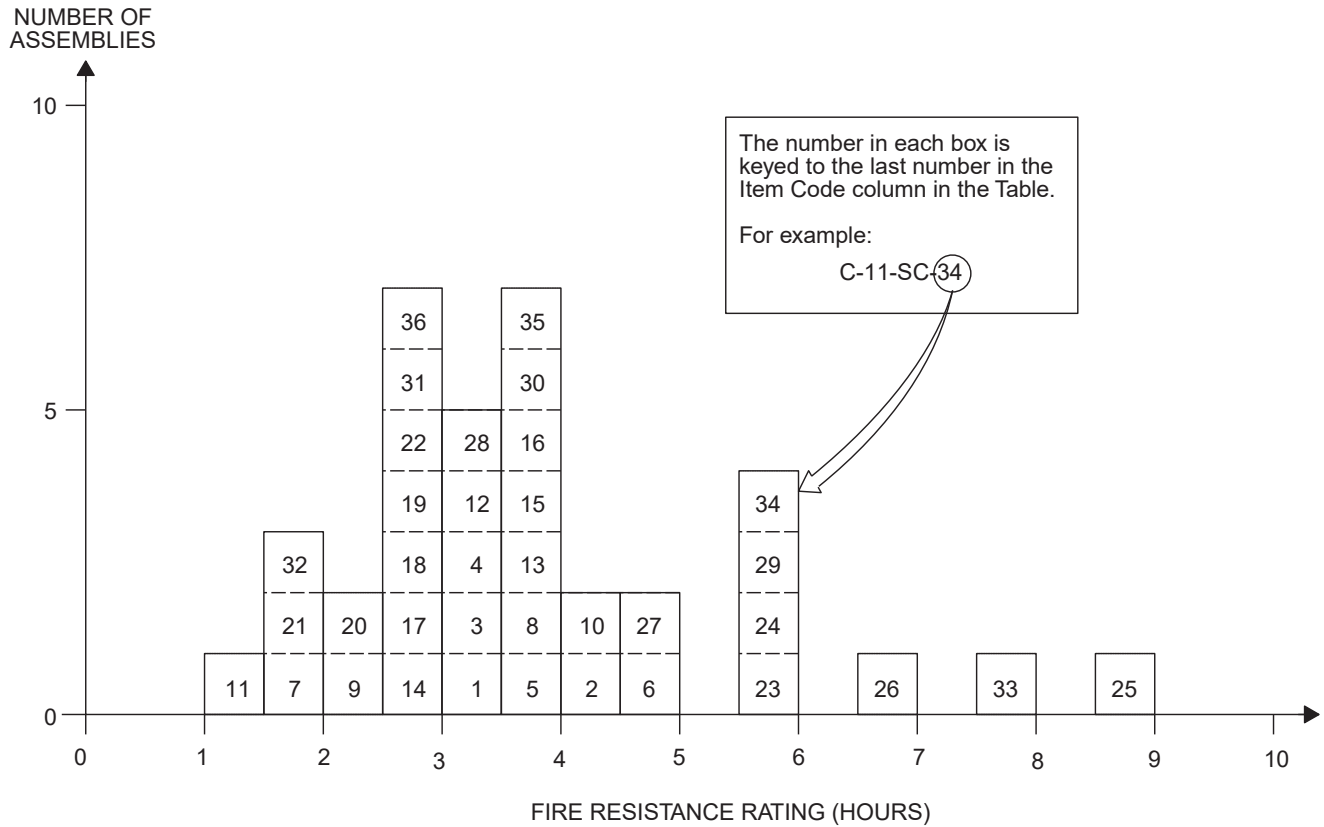

TABLE 2.5.1.4
STEEL COLUMNS—CONCRETE ENCASEMENTS
MINIMUM DIMENSION 10" TO LESS THAN 12"

ITEM CODE	MINIMUM DIMENSION	CONSTRUCTION DETAILS	PERFORMANCE		REFERENCE NUMBER			NOTES	REC. HOURS
			LOAD	TIME	PRE-BMS-92	BMS-92	POST-BMS-92		
C-10-SC-1	10"	10" × 12" concrete encased steel column; 8" × 6" × 35 lbs. "H" beam; Protection: gravel aggregate concrete (3640 psi); Mesh 6" × 4" 13 SWG, 1" below column surface.	90 tons	3 hrs. 7 min.			7	1,2	3
C-10-SC-2	10"	10" × 16" column; 8" × 6" × 35 lbs. "H" beam; Protection: clay brick concrete (3630 psi); 6" × 4" mesh; 13 SWG, 1" below column surface.	90 tons	4 hrs. 6 min.			7	2	4
C-10-SC-3	10"	10" × 12" column; 8" × 6" × 35 lbs. "H" beam; Protection: crushed stone and sand concrete (3930 psi); 6" × 4" - 13 SWG mesh; 1" below column surface.	90 tons	3 hrs. 17 min.			7	2	3 ¹ / ₄
C-10-SC-4	10"	10" × 12" column; 8" × 6" × 35 lbs. "H" beam; Protection: crushed basalt and sand concrete (4350 psi); 6" × 4" - 13 SWG mesh; 1" below column surface.	90 tons	3 hrs. 22 min.			7	2	3 ¹ / ₃
C-10-SC-5	10"	10" × 12" column; 8" × 6" × 35 lbs. "H" beam; Protection: gravel aggregate concrete (5570 psi); 6" × 4" mesh; 13 SWG.	90 tons	3 hrs. 39 min.			7	2	3 ¹ / ₂
C-10-SC-6	10"	10" × 16" column; 8" × 6" × 35 lbs. "I" beam; Protection: gravel concrete (4950 psi); mesh; 6" × 4" 13 SWG 1" below column surface.	90 tons	4 hrs. 32 min.			7	2	4 ¹ / ₂

(continued)

TABLE 2.5.1.4—continued
STEEL COLUMNS—CONCRETE ENCASEMENTS
MINIMUM DIMENSION 10" TO LESS THAN 12"

ITEM CODE	MINIMUM DIMENSION	CONSTRUCTION DETAILS	PERFORMANCE		REFERENCE NUMBER			NOTES	REC. HOURS
			LOAD	TIME	PRE-BMS-92	BMS-92	POST-BMS-92		
C-10-SC-7	10"	10" × 12" concrete encased steel column; 8" × 6" × 35 lbs. "H" beam; Protection: aggregate concrete (1370 psi); 6" × 4" mesh; 13 SWG reinforcing 1" below column surface.	90 tons	2 hrs.			7	3, 4	2
C-10-SC-8	10"	10" × 12" concrete encased steel column; 8" × 6" × 35 lbs. "H" column; Protection: aggregate concrete (4000 psi); 13 SWG iron wire loosely around column at 6" pitch about 2" beneath column surface.	86 tons	3 hrs. 36 min.			7	2	3½
C-10-SC-9	10"	10" × 12" concrete encased steel column; 8" × 6" × 35 lbs. "H" beam; Protection: aggregate concrete (3290 psi); 2" cover minimum.	86 tons	2 hrs. 8 min.			7	2	2
C-10-SC-10	10"	10" × 14" concrete encased steel column; 8" × 6" × 35 lbs. "H" column; Protection: crushed brick filled concrete (5310 psi); 6" × 4" mesh; 13 SWG reinforcement 1" below column surface.	90 tons	4 hrs. 28 min.			7	2	4⅓
C-10-SC-11	10"	10" × 14" concrete encased column; 8" × 6" × 35 lbs. "H" beam; Protection: aggregate concrete (342 psi); 6" × 4" mesh; 13 SWG reinforcement 1" below surface.	90 tons	1 hr. 2 min.			7	2	1
C-10-SC-12	10"	10" × 12" concrete encased steel column; 8" × 6" × 35 lbs. "H" beam; Protection: aggregate concrete (4480 psi); four 3/8" vertical bars at "H" beam edges with 3/16" spacers at beam surface at 3' pitch and 3/16" binders at 10" pitch; 2" concrete cover.	90 tons	3 hrs. 2 min.			7	2	3
C-10-SC-13	10"	10" × 12" concrete encased steel column; 8" × 6" × 35 lbs. "H" beam; Protection: aggregate concrete (5070 psi); 6" × 4" mesh; 13 SWG reinforcing at 6" beam sides wrapped and held by wire ties across (open) 8" beam face; reinforcements wrapped in 6" × 4" mesh; 13 SWG throughout; ½" cover to column surface.	90 tons	3 hrs. 59 min.			7	2	3¾
C-10-SC-14	10"	10" × 12" concrete encased steel column; 8" × 6" × 35 lbs. "H" beam; Protection: aggregate concrete (4410 psi); 6" × 4" mesh; 13 SWG reinforcement 1¼" below column surface; ½" limestone cement plaster with 3/8" gypsum plaster finish.	90 tons	2 hrs. 50 min.			7	2	2¾
C-10-SC-15	10"	10" × 12" concrete encased steel column; 8" × 6" × 35 lbs. "H" beam; Protection: crushed clay brick filled concrete (4260 psi); 6" × 4" mesh; 13 SWG reinforcing 1" below column surface.	90 tons	3 hrs. 54 min.			7	2	3¾
C-10-SC-16	10"	10" × 12" concrete encased steel column; 8" × 6" × 35 lbs. "H" beam; Protection: limestone aggregate concrete (4350 psi); 6" × 4" mesh; 13 SWG reinforcing 1" below column surface.	90 tons	3 hrs. 54 min.			7	2	3¾

(continued)

TABLE 2.5.1.4—continued
STEEL COLUMNS—CONCRETE ENCASEMENTS
MINIMUM DIMENSION 10" TO LESS THAN 12"

ITEM CODE	MINIMUM DIMENSION	CONSTRUCTION DETAILS	PERFORMANCE		REFERENCE NUMBER			NOTES	REC. HOURS
			LOAD	TIME	PRE-BMS-92	BMS-92	POST-BMS-92		
C-10-SC-17	10"	10" × 12" concrete encased steel column; 8" × 6" × 35 lbs. "H" beam; Protection: limestone aggregate concrete (5300 psi); 6" × 4"; 13 SWG wire mesh 1" below column surface.	90 tons	3 hrs.			7	4, 5	3
C-10-SC-18	10"	10" × 12" concrete encased steel column; 8" × 6" × 35 lbs. "H" beam; Protection: limestone aggregate concrete (4800 psi) with 6" × 4"; 13 SWG mesh reinforcement 1" below surface.	90 tons	3 hrs.			7	4, 5	3
C-10-SC-19	10"	10" × 14" concrete encased steel column; 12" × 8" × 65 lbs. "H" beam; Protection: aggregate concrete (3900 psi); 4" mesh; 16 SWG reinforcing 1/2" below column surface.	118 tons	2 hrs. 42 min.			7	2	2
C-10-SC-20	10"	10" × 14" concrete encased steel column; 12" × 8" × 65 lbs. "H" beam; Protection: aggregate concrete (4930 psi); 4" mesh; 16 SWG reinforcing 1/2" below column surface.	177 tons	2 hrs. 8 min.			7	2	2
C-10-SC-21	10 ^{3/8} "	10 ^{3/8} " × 12 ^{3/8} " concrete encased steel column; 8" × 6" × 35 lbs. "H" beam; Protection: aggregate concrete (835 psi) with 6" × 4" mesh; 13 SWG reinforcing 1 ^{3/16} " below column surface; 3/16" gypsum plaster finish.	90 tons	2 hrs.			7	3, 4	2
C-11-SC-22	11"	11" × 13" concrete encased steel column; 8" × 6" × 35 lbs. "H" beam; Protection: "open texture" brick filled concrete (890 psi) with 6" × 4" mesh; 13 SWG reinforcing 1 1/2" below column surface; 3/8" lime cement plaster; 1/8" gypsum plaster finish.	90 tons	3 hrs.			7	6, 7	3
C-11-SC-23	11"	11" × 12" column; 4" × 3" × 10 lbs. "H" beam; gravel concrete (4550 psi); 6" × 4" - 13 SWG mesh reinforcing; 1" below column surface.	12 tons	6 hrs.			7	7, 8	6
C-11-SC-24	11"	11" × 12" column; 4" × 3" × 10 lbs. "H" beam; Protection: gravel aggregate concrete (3830 psi); with 4" × 4" mesh; 16 SWG, 1" below column surface.	16 tons	5 hrs. 32 min.			7	2	5 1/2
C-10-SC-25	10"	6" × 6" steel column with 4" outside protection; Group I.	—	9 hrs.			1	9	9
C-10-SC-26	10"	Description as per C-SC-25; Group II.	—	7 hrs.			1	9	7
C-10-SC-27	10"	Description as per C-10-SC-25; Group III.	—	5 hrs.			1	9	5
C-10-SC-28	10"	Description as per C-10-SC-25; Group IV.	—	3 hrs. 30 min.			1	9	3 1/2
C-10-SC-29	10"	8" × 8" steel column with 2" outside protection; Group I.	—	6 hrs.			1	9	6
C-10-SC-30	10"	Description as per C-10-SC-29; Group II.	—	4 hrs.			1	9	4
C-10-SC-31	10"	Description as per C-10-SC-29; Group III.	—	3 hrs.			1	9	3
C-10-SC-32	10"	Description as per C-10-SC-29; Group IV.	—	2 hrs.			1	9	2

(continued)

RESOURCE A

**TABLE 2.5.1.4—continued
STEEL COLUMNS—CONCRETE ENCASEMENTS
MINIMUM DIMENSION 10" TO LESS THAN 12"**

ITEM CODE	MINIMUM DIMENSION	CONSTRUCTION DETAILS	PERFORMANCE		REFERENCE NUMBER			NOTES	REC. HOURS
			LOAD	TIME	PRE-BMS-92	BMS-92	POST-BMS-92		
C-11-SC-33	11"	8" × 8" steel column with 3" outside protection; Group I.	—	8 hrs.		1		9	8
C-11-SC-34	11"	Description as per C-10-SC-33; Group II.	—	6 hrs.		1		9	6
C-11-SC-35	11"	Description as per C-10-SC-33; Group III.	—	4 hrs.		1		9	4
C-11-SC-36	11"	Description as per C-10-SC-33; Group IV.	—	3 hrs.		1		9	3

For SI: 1 inch = 25.4 mm, 1 pound = 0.004448 kN, 1 pound per square inch = 0.00689 MPa, 1 pound per square yard = 5.3 N/m², 1 ton = 8.896 kN.

Notes:

1. Tested under total restraint load to prevent expansion—minimum load 90 tons.
2. Failure mode—collapse.
3. Passed 2-hour fire test (Grade "C," British).
4. Passed hose stream test.
5. Column tested and passed 3-hour grade fire resistance (British).
6. Column passed 3-hour fire test.
7. Column collapsed during hose stream testing.
8. Column passed 6-hour fire test.
9. Group I: includes concrete having calcareous aggregate containing a combined total of not more than 10 percent of quartz, chert and flint for the coarse aggregate.
Group II: includes concrete having trap-rock aggregate applied without metal ties and also concrete having cinder, sandstone or granite aggregate, if held in place with wire mesh or expanded metal having not larger than 4-inch mesh, weighing not less than 1.7 lbs./yd.², placed not more than 1 inch from the surface of the concrete.
Group III: includes concrete having cinder, sandstone or granite aggregate tied with No. 5 gage steel wire, wound spirally over the column section on a pitch of 8 inches, or equivalent ties, and concrete having siliceous aggregates containing a combined total of 60 percent or more of quartz, chert and flint, if held in place with wire mesh or expanded metal having not larger than 4-inch mesh, weighing not less than 1.7 lbs./yd.², placed not more than 1 inch from the surface of the concrete.
Group IV: includes concrete having siliceous aggregates containing a combined total of 60 percent or more of quartz, chert and flint, and tied with No. 5 gage steel wire wound spirally over the column section on a pitch of 8 inches, or equivalent ties.

FIGURE 2.5.1.5
STEEL COLUMNS—CONCRETE ENCASEMENTS
MINIMUM DIMENSION 12" TO LESS THAN 14"

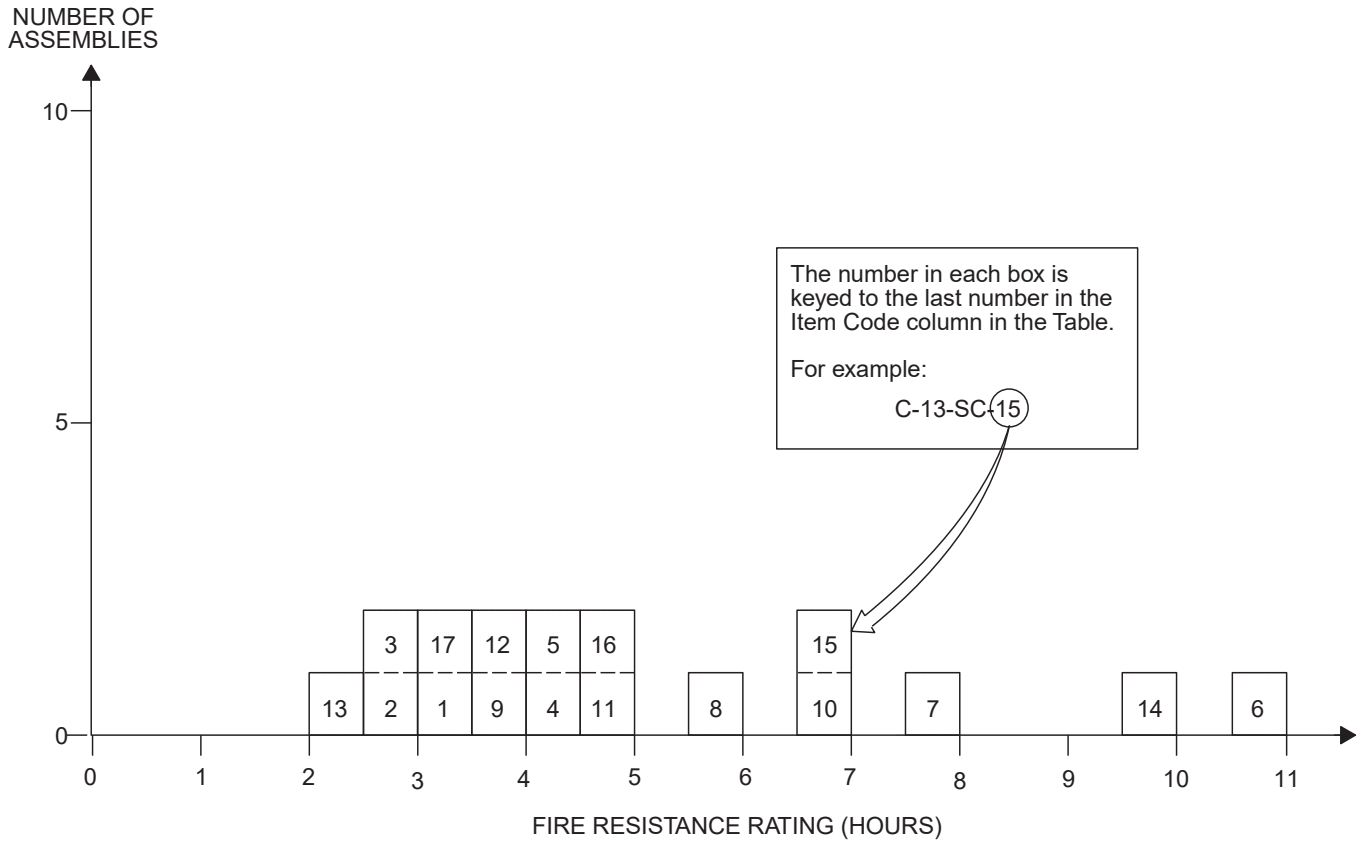

TABLE 2.5.1.5
STEEL COLUMNS—CONCRETE ENCASEMENTS
MINIMUM DIMENSION 12" TO LESS THAN 14"

ITEM CODE	MINIMUM DIMENSION	CONSTRUCTION DETAILS	PERFORMANCE		REFERENCE NUMBER			NOTES	REC. HOURS
			LOAD	TIME	PRE-BMS-92	BMS-92	POST-BMS-92		
C-12-SC-1	12"	12" × 14" concrete encased steel column; 8" × 6" × 35 lbs. "H" beam; Protection: aggregate concrete (4150 psi) with 4" mesh; 16 SWG reinforcing 1" below column surface.	120 tons	3 hrs. 24 min.			7	1	3 ¹ / ₃
C-12-SC-2	12"	12" × 16" concrete encased column; 8" × 6" × 35 lbs. "H" beam; Protection: aggregate concrete (4300 psi) with 4" mesh; 16 SWG reinforcing 1" below column surface.	90 tons	2 hrs. 52 min.			7	1	2 ³ / ₄
C-12-SC-3	12"	12" × 16" concrete encased steel column; 12" × 8" × 65 lbs. "H" column; Protection: gravel aggregate concrete (3550 psi) with 4" mesh; 16 SWG reinforcement 1" below column surface.	177 tons	2 hrs. 31 min.			7	1	2 ¹ / ₂
C-12-SC-4	12"	12" × 16" concrete encased column; 12" × 8" × 65 lbs. "H" beam; Protection: aggregate concrete (3450 psi) with 4" mesh; 16 SWG reinforcement 1" below column surface.	118 tons	4 hrs. 4 min.			7	1	4

(continued)

**TABLE 2.5.1.5—continued
STEEL COLUMNS—CONCRETE ENCASEMENTS
MINIMUM DIMENSION 12" TO LESS THAN 14"**

ITEM CODE	MINIMUM DIMENSION	CONSTRUCTION DETAILS	PERFORMANCE		REFERENCE NUMBER			NOTES	REC. HOURS
			LOAD	TIME	PRE-BMS-92	BMS-92	POST-BMS-92		
C-12-SC-5	12 ¹ / ₂ "	12 ¹ / ₂ " × 14" column; 6" × 4 ¹ / ₂ " × 20 lbs. "H" beam; Protection: gravel aggregate concrete (3750 psi) with 4" × 4" mesh; 16 SWG reinforcing 1" below column surface.	52 tons	4 hrs. 29 min.			7	1	4 ¹ / ₃
C-12-SC-6	12"	8" × 8" steel column; 2" outside protection; Group I.	—	11 hrs.			1	2	11
C-12-SC-7	12"	Description as per C-12-SC-6; Group II.	—	8 hrs.		1		2	8
C-12-SC-8	12"	Description as per C-12-SC-6; Group III.	—	6 hrs.		1		2	6
C-12-SC-9	12"	Description as per C-12-SC-6; Group IV.	—	4 hrs.		1		2	4
C-12-SC-10	12"	10" × 10" steel column; 2" outside protection; Group I.	—	7 hrs.		1		2	7
C-12-SC-11	12"	Description as per C-12-SC-10; Group II.	—	5 hrs.		1		2	5
C-12-SC-12	12"	Description as per C-12-SC-10; Group III.	—	4 hrs.		1		2	4
C-12-SC-13	12"	Description as per C-12-SC-10; Group IV.	—	2 hrs. 30 min.		1		2	2 ¹ / ₂
C-13-SC-14	13"	10" × 10" steel column; 3" outside protection; Group I.	—	10 hrs.		1		2	10
C-13-SC-15	13"	Description as per C-12-SC-14; Group II.	—	7 hrs.		1		2	7
C-13-SC-16	13"	Description as per C-12-SC-14; Group III.	—	5 hrs.		1		2	5
C-13-SC-17	13"	Description as per C-12-SC-14; Group IV.	—	3 hrs. 30 min.		1		2	3 ¹ / ₂

For SI: 1 inch = 25.4 mm, 1 pound = 0.004448 kN, 1 pound per square inch = 0.00689 MPa, 1 pound per square yard = 5.3 N/m², 1 ton = 8.896 kN.

Notes:

1. Failure mode—collapse.
2. Group I: includes concrete having calcareous aggregate containing a combined total of not more than 10 percent of quartz, chert and flint for the coarse aggregate.
Group II: includes concrete having trap-rock aggregate applied without metal ties and also concrete having cinder, sandstone or granite aggregate, if held in place with wire mesh or expanded metal having not larger than 4-inch mesh, weighing not less than 1.7 lbs./yd.², placed not more than 1 inch from the surface of the concrete.
Group III: includes concrete having cinder, sandstone or granite aggregate tied with No. 5 gage steel wire, wound spirally over the column section on a pitch of 8 inches, or equivalent ties, and concrete having siliceous aggregates containing a combined total of 60 percent or more of quartz, chert and flint, if held in place with wire mesh or expanded metal having not larger than 4-inch mesh, weighing not less than 1.7 lbs./yd.², placed not more than 1 inch from the surface of the concrete.
Group IV: includes concrete having siliceous aggregates containing a combined total of 60 percent or more of quartz, chert and flint, and tied with No. 5 gage steel wire wound spirally over the column section on a pitch of 8 inches, or equivalent ties.

FIGURE 2.5.1.6
STEEL COLUMNS—CONCRETE ENCASEMENTS
MINIMUM DIMENSION 14" TO LESS THAN 16"

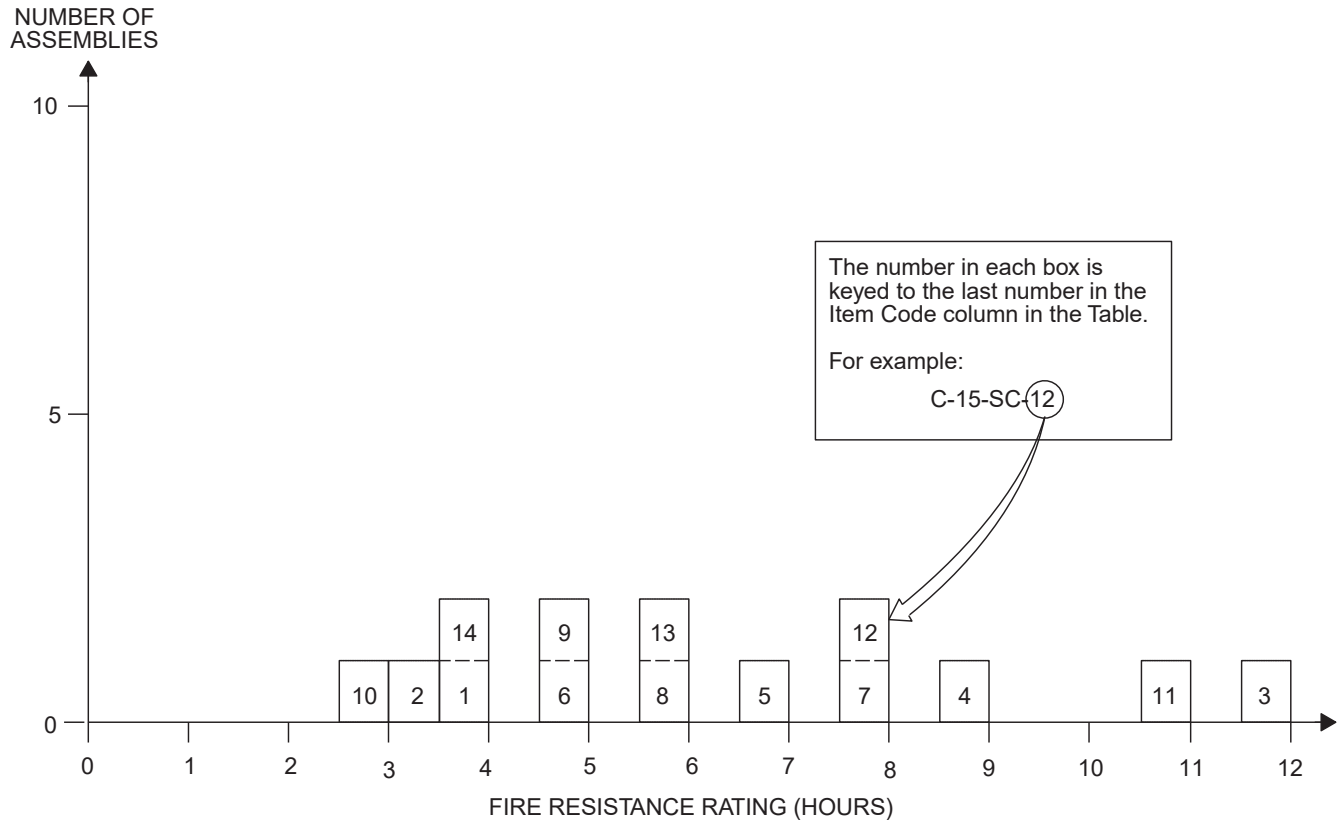

TABLE 2.5.1.6
STEEL COLUMNS—CONCRETE ENCASEMENTS
MINIMUM DIMENSION 14" TO LESS THAN 16"

ITEM CODE	MINIMUM DIMENSION	CONSTRUCTION DETAILS	PERFORMANCE		REFERENCE NUMBER			NOTES	REC. HOURS
			LOAD	TIME	PRE-BMS-92	BMS-92	POST-BMS-92		
C-14-SC-1	14"	24" × 16" concrete encased steel column; 8" × 6" × 35 lbs. "H" column; Protection: aggregate concrete (4240 psi); 4" mesh - 16 SWG reinforcing 1" below column surface.	90 tons	3 hrs. 40 min.			7	1	3
C-14-SC-2	14"	14" × 18" concrete encased steel column; 12" × 8" × 65 lbs. "H" beam; Protection: gravel aggregate concrete (4000 psi) with 4" - 16 SWG wire mesh reinforcement 1" below column surface.	177 tons	3 hrs. 20 min.			7	1	3
C-14-SC-3	14"	10" × 10" steel column; 4" outside protection; Group I.	—	12 hrs.		1		2	12
C-14-SC-4	14"	Description as per C-14-SC-3; Group II.	—	9 hrs.		1		2	9
C-14-SC-1	14"	24" × 16" concrete encased steel column; 8" × 6" × 35 lbs. "H" column; Protection: aggregate concrete (4240 psi); 4" mesh - 16 SWG reinforcing 1" below column surface.	90 tons	3 hrs. 40 min.			7	1	3

(continued)

**TABLE 2.5.1.6—continued
STEEL COLUMNS—CONCRETE ENCASEMENTS
MINIMUM DIMENSION 14" TO LESS THAN 16"**

ITEM CODE	MINIMUM DIMENSION	CONSTRUCTION DETAILS	PERFORMANCE		REFERENCE NUMBER			NOTES	REC. HOURS
			LOAD	TIME	PRE-BMS-92	BMS-92	POST-BMS-92		
C-14-SC-2	14"	14" × 18" concrete encased steel column; 12" × 8" × 65 lbs. "H" beam; Protection: gravel aggregate concrete (4000 psi) with 4"-16 SWG wire mesh reinforcement 1" below column surface.	177 tons	3 hrs. 20 min.			7	1	3
C-14-SC-3	14"	10" × 10" steel column; 4" outside protection; Group I.	—	12 hrs.		1		2	12
C-14-SC-4	14"	Description as per C-14-SC-3; Group II.	—	9 hrs.		1		2	9
C-14-SC-5	14"	Description as per C-14-SC-3; Group III.	—	7 hrs.		1		2	7
C-14-SC-6	14"	Description as per C-14-SC-3; Group IV.	—	5 hrs.		1		2	5
C-14-SC-7	14"	12" × 12" steel column; 2" outside protection; Group I.	—	8 hrs.		1		2	8
C-14-SC-8	14"	Description as per C-14-SC-7; Group II.	—	6 hrs.		1		2	6
C-14-SC-9	14"	Description as per C-14-SC-7; Group III.	—	5 hrs.		1		2	5
C-14-SC-10	14"	Description as per C-14-SC-7; Group IV	—	3 hrs.		1		2	3
C-15-SC-11	15"	12" × 12" steel column; 3" outside protection; Group I.	—	11 hrs.		1		2	11
C-15-SC-12	15"	Description as per C-15-SC-11; Group II.	—	8 hrs.		1		2	8
C-15-SC-13	15"	Description as per C-15-SC-11; Group III.	—	6 hrs.		1		2	6
C-15-SC-14	15"	Description as per C-15-SC-11; Group IV.	—	4 hrs.		1		2	4

For SI: 1 inch = 25.4 mm, 1 pound = 0.004448 kN, 1 pound per square inch = 0.00689 MPa, 1 pound per square yard = 5.3 N/m², 1 ton = 8.896 kN.

Notes:

1. Collapse.
2. Group I: includes concrete having calcareous aggregate containing a combined total of not more than 10 percent of quartz, chert and flint for the coarse aggregate.
Group II: includes concrete having trap-rock aggregate applied without metal ties and also concrete having cinder, sandstone or granite aggregate, if held in place with wire mesh or expanded metal having not larger than 4-inch mesh, weighing not less than 1.7 lbs./yd.², placed not more than 1 inch from the surface of the concrete.
Group III: includes concrete having cinder, sandstone or granite aggregate tied with No. 5 gage steel wire, wound spirally over the column section on a pitch of 8 inches, or equivalent ties, and concrete having siliceous aggregates containing a combined total of 60 percent or more of quartz, chert and flint, if held in place with wire mesh or expanded metal having not larger than 4-inch mesh, weighing not less than 1.7 lbs./yd.², placed not more than 1 inch from the surface of the concrete.
Group IV: includes concrete having siliceous aggregates containing a combined total of 60 percent or more of quartz, chert and flint, and tied with No. 5 gage steel wire wound spirally over the column section on a pitch of 8 inches, or equivalent ties.

**TABLE 2.5.1.7
STEEL COLUMNS—CONCRETE ENCASEMENTS
MINIMUM DIMENSION 16" TO LESS THAN 18"**

ITEM CODE	MINIMUM DIMENSION	CONSTRUCTION DETAILS	PERFORMANCE		REFERENCE NUMBER			NOTES	REC. HOURS
			LOAD	TIME	PRE-BMS-92	BMS-92	POST-BMS-92		
C-16-SC-13	16"	12" × 12" steel column; 4" outside protection; Group I.	—	14 hrs.		1		1	14
C-16-SC-2	16"	Description as per C-16-SC-1; Group II.	—	10 hrs.		1		1	10
C-16-SC-3	16"	Description as per C-16-SC-1; Group III.	—	8 hrs.		1		1	8
C-16-SC-4	16"	Description as per C-16-SC-1; Group IV.	—	5 hrs.		1		1	5

For SI: 1 inch = 25.4 mm.

Notes:

- Group I: includes concrete having calcareous aggregate containing a combined total of not more than 10 percent of quartz, chert and flint for the coarse aggregate.
Group II: includes concrete having trap-rock aggregate applied without metal ties and also concrete having cinder, sandstone or granite aggregate, if held in place with wire mesh or expanded metal having not larger than 4-inch mesh, weighing not less than 1.7 lbs./yd.², placed not more than 1 inch from the surface of the concrete.
Group III: includes concrete having cinder, sandstone or granite aggregate tied with No. 5 gage steel wire, wound spirally over the column section on a pitch of 8 inches, or equivalent ties, and concrete having siliceous aggregates containing a combined total of 60 percent or more of quartz, chert and flint, if held in place with wire mesh or expanded metal having not larger than 4-inch mesh, weighing not less than 1.7 lbs./yd.², placed not more than 1 inch from the surface of the concrete.
Group IV: includes concrete having siliceous aggregates containing a combined total of 60 percent or more of quartz, chert and flint, and tied with No. 5 gage steel wire wound spirally over the column section on a pitch of 8 inches, or equivalent ties.

**TABLE 2.5.2.1
STEEL COLUMNS—BRICK AND BLOCK ENCASEMENTS
MINIMUM DIMENSION 10" TO LESS THAN 12"**

ITEM CODE	MINIMUM DIMENSION	CONSTRUCTION DETAILS	PERFORMANCE		REFERENCE NUMBER			NOTES	REC. HOURS
			LOAD	TIME	PRE-BMS-92	BMS-92	POST-BMS-92		
C-10-SB-1	10½"	10½" × 13" brick encased steel columns; 8" × 6" × 35 lbs. "H" beam; Protection. Fill of broken brick and mortar; 2" brick on edge; joints broken in alternate courses; cement-sand grout; 13 SWG wire reinforcement in every third horizontal joint.	90 tons	3 hrs. 6 min.			7	1	3
C-10-SB-2	10½"	10½" × 13" brick encased steel columns; 8" × 6" × 35 lbs. "H" beam; Protection: 2" brick; joints broken in alternate courses; cement-sand grout; 13 SWG iron wire reinforcement in alternate horizontal joints.	90 tons	2 hrs.			7	2, 3, 4	2
C-10-SB-3	10"	10" × 12" block encased columns; 8" × 6" × 35 lbs. "H" beam; Protection: 2" foamed slag concrete blocks; 13 SWG wire at each horizontal joint; mortar at each joint.	90 tons	2 hrs.			7	5	2
C-10-SB-4	10½"	10½" × 12" block encased steel columns; 8" × 6" × 35 lbs. "H" beam; Protection: gravel aggregate concrete fill (unconsolidated) 2" thick hollow clay tiles with mortar at edges.	86 tons	56 min.			7	1	¾
C-10-SB-5	10½"	10½" × 12" block encased steel columns; 8" × 6" × 35 lbs. "H" beam; Protection: 2" hollow clay tiles with mortar at edges.	86 tons	22 min.			7	1	¼

For SI: 1 inch = 25.4 mm, 1 pound = 0.004448 kN, 1 ton = 8.896 kN.

Notes:

- Failure mode—collapse.
- Passed 2-hour fire test (Grade "C" - British).
- Passed hose stream test.
- Passed reload test.
- Passed 2-hour fire exposure but collapsed immediately following hose stream test.

RESOURCE A

**TABLE 2.5.2.2
STEEL COLUMNS—BRICK AND BLOCK ENCASEMENTS
MINIMUM DIMENSION 12" TO LESS THAN 14"**

ITEM CODE	MINIMUM DIMENSION	CONSTRUCTION DETAILS	PERFORMANCE		REFERENCE NUMBER			NOTES	REC. HOURS
			LOAD	TIME	PRE-BMS-92	BMS-92	POST-BMS-92		
C-12-SB-1	12"	12" × 15" brick encased steel columns; 8" × 6" × 35 lbs. "H" beam; Protection: 2 ⁵ / ₈ " thick brick; joints broken in alternate courses; cement-sand grout; fill of broken brick and mortar.	90 tons	1 hr. 49 min.			7	1	1 ³ / ₄

For SI: 1 inch = 25.4 mm, 1 pound = 0.004448 kN, 1 ton = 8.896 kN.

Notes:

1. Failure mode—collapse.

**TABLE 2.5.2.3
STEEL COLUMNS—BRICK AND BLOCK ENCASEMENTS
MINIMUM DIMENSION 14" TO LESS THAN 16"**

ITEM CODE	MINIMUM DIMENSION	CONSTRUCTION DETAILS	PERFORMANCE		REFERENCE NUMBER			NOTES	REC. HOURS
			LOAD	TIME	PRE-BMS-92	BMS-92	POST-BMS-92		
C-15-SB-1	15"	15" × 17" brick encased steel columns; 8" × 6" × 35 lbs. "H" beam; Protection: 4 ¹ / ₂ " thick brick; joints broken in alternate courses; cement-sand grout; fill of broken brick and mortar.	45 tons	6 hrs.			7	1	6
C-15-SB-2	15"	15" × 17" brick encased steel columns; 8" × 6" × 35 lbs. "H" beam; Protection. Fill of broken brick and mortar; 4 ¹ / ₂ " brick; joints broken in alternate courses; cement-sand grout.	86 tons	6 hrs.			7	2, 3, 4	6
C-15-SB-3	15"	15" × 18" brick encased steel columns; 8" × 6" × 35 lbs. "H" beam; Protection: 4 ¹ / ₂ " brick work; joints alternating; cement-sand grout.	90 tons	4 hrs.			7	5, 6	4
C-15-SB-4	14"	14" × 16" block encased steel columns; 8" × 6" × 35 lbs. "H" beam; Protection: 4" thick foam slag concrete blocks; 13 SWG wire reinforcement in each horizontal joint; mortar in joints.	90 tons	5 hrs. 52 min.			7	7	4 ³ / ₄

For SI: 1 inch = 25.4 mm, 1 pound = 0.004448 kN, 1 ton = 8.896 kN.

Notes:

1. Only a nominal load was applied to specimen.
2. Passed 6-hour fire test (Grade "A" - British).
3. Passed (6 minute) hose stream test.
4. Reload not specified.
5. Passed 4-hour fire exposure.
6. Failed by collapse between first and second minute of hose stream exposure.
7. Mode of failure-collapse.

**TABLE 2.5.3.1
STEEL COLUMNS—PLASTER ENCASEMENTS
MINIMUM DIMENSION 6" TO LESS THAN 8"**

ITEM CODE	MINIMUM DIMENSION	CONSTRUCTION DETAILS	PERFORMANCE		REFERENCE NUMBER			NOTES	REC. HOURS
			LOAD	TIME	PRE-BMS-92	BMS-92	POST-BMS-92		
C-7-SP-1	7 ¹ / ₂ "	7 ¹ / ₂ " × 9 ¹ / ₂ " plaster protected steel columns; 8" × 6" × 35 lbs. "H" beam; Protection: 24 SWG wire metal lath; 1 ¹ / ₄ " lime plaster.	90 tons	57 min.			7	1	3/4
C-7-SP-2	7 ⁷ / ₈ "	7 ⁷ / ₈ " × 10" plaster protected steel columns; 8" × 6" × 35 lbs. "H" beam; Protection: 3/8" gypsum bal wire wound with 16 SWG wire helically wound at 4" pitch; 1/2" gypsum plaster.	90 tons	1 hr. 13 min.			7	1	1
C-7-SP-3	7 ¹ / ₄ "	7 ¹ / ₄ " × 9 ³ / ₈ " plaster protected steel columns; 8" × 6" × 35 lbs. "H" beam; Protection: 3/8" gypsum board; wire helically wound 16 SWG at 4" pitch; 1/4" gypsum plaster finish.	90 tons	1 hr. 14 min.			7	1	1

Notes:

1. Failure mode—collapse.

**TABLE 2.5.3.2
STEEL COLUMNS—PLASTER ENCASEMENTS
MINIMUM DIMENSION 8" TO LESS THAN 10"**

ITEM CODE	MINIMUM DIMENSION	CONSTRUCTION DETAILS	PERFORMANCE		REFERENCE NUMBER			NOTES	REC. HOURS
			LOAD	TIME	PRE-BMS-92	BMS-92	POST-BMS-92		
C-8-SP-1	8"	8" × 10" plaster protected steel columns; 8" × 6" × 35 lbs. "H" beam; Protection: 24 SWG wire lath; 1" gypsum plaster.	86 tons	1 hr. 23 min.			7	1	1 ¹ / ₄
C-8-SP-2	8 ¹ / ₂ "	8 ¹ / ₂ " × 10 ¹ / ₂ " plaster protected steel columns; 8" × 6" × 35 lbs. "H" beam; Protection: 24 SWG metal lath wrap; 1 ¹ / ₄ " gypsum plaster.	90 tons	1 hr. 36 min.			7	1	1 ¹ / ₂
C-9-SP-3	9"	9" × 11" plaster protected steel columns; 8" × 6" × 35 lbs. "H" beam; Protection: 24 SWG metal lath wrap; 1/8" M.S. ties at 12" pitch wire netting 1 ¹ / ₂ " × 22 SWG between first and second plaster coats; 1 ¹ / ₂ " gypsum plaster.	90 tons	1 hr. 33 min.			7	1	1 ¹ / ₂
C-8-SP-4	8 ³ / ₄ "	8 ³ / ₄ " × 10 ³ / ₄ " plaster protected steel columns; 8" × 6" × 35 lbs. "H" beam; Protection: 3/4" gypsum board; wire wound spirally (#16 SWG) at 1 ¹ / ₂ " pitch; 1/2" gypsum plaster.	90 tons	2 hrs.			7	2, 3, 4	2

For SI: 1 inch = 25.4 mm, 1 pound = 0.004448 kN, 1 ton = 8.896 kN.

Notes:

1. Failure mode—collapse.
2. Passed 2 hour fire exposure test (Grade "C" - British).
3. Passed hose stream test.

**TABLE 2.5.4.1
STEEL COLUMNS—MISCELLANEOUS ENCASEMENTS
MINIMUM DIMENSION 6" TO LESS THAN 8"**

ITEM CODE	MINIMUM DIMENSION	CONSTRUCTION DETAILS	PERFORMANCE		REFERENCE NUMBER			NOTES	REC. HOURS
			LOAD	TIME	PRE-BMS-92	BMS-92	POST-BMS-92		
C-7-SM-1	7 ⁵ / ₈ "	7 ⁵ / ₈ " × 9 ¹ / ₂ " (asbestos plaster) protected steel columns; 8" × 6" × 35 lbs. "H" beam; Protection: 20 gage 1/2" metal lath; 9/16" asbestos plaster (minimum).	90 tons	1 hr. 52 min.			7	1	1 ³ / ₄

For SI: 1 inch = 25.4 mm, 1 pound = 0.004448 kN, 1 ton = 8.896 kN.

Notes:

1. Failure mode—collapse.

**TABLE 2.5.4.2
STEEL COLUMNS—MISCELLANEOUS ENCASEMENTS
MINIMUM DIMENSION 8" TO LESS THAN 10"**

ITEM CODE	MINIMUM DIMENSION	CONSTRUCTION DETAILS	PERFORMANCE		REFERENCE NUMBER			NOTES	REC. HOURS
			LOAD	TIME	PRE-BMS-92	BMS-92	POST-BMS-92		
C-9-SM-1	9 ⁵ / ₈ "	9 ⁵ / ₈ " × 11 ³ / ₈ " asbestos slab and cement plaster protected columns; 8" × 6" × 35 lbs. "H" beam; Protection: 1" asbestos slab; wire wound; ⁵ / ₈ " plaster.	90 tons	2 hrs.			7	1, 2	2

For SI: 1 inch = 25.4 mm, 1 pound = 0.004448 kN, 1 ton = 8.896 kN.

Notes:

1. Passed 2 hour fire exposure test.
2. Collapsed during hose stream test.

**TABLE 2.5.4.3
STEEL COLUMNS—MISCELLANEOUS ENCASEMENTS
MINIMUM DIMENSION 10" TO LESS THAN 12"**

ITEM CODE	MINIMUM DIMENSION	CONSTRUCTION DETAILS	PERFORMANCE		REFERENCE NUMBER			NOTES	REC. HOURS
			LOAD	TIME	PRE-BMS-92	BMS-92	POST-BMS-92		
C-11-SM-1	11 ¹ / ₂ "	11 ¹ / ₂ " × 13 ¹ / ₂ " wood wool and plaster protected steel columns; 8" × 6" × 35 lbs. "H" beam; Protection: wood-wool-cement paste as fill and to 2" cover over beam; ³ / ₄ " gypsum plaster finish.	90 tons	2 hrs.			7	1, 2, 3	2
C-10-SM-1	10"	10" × 12" asbestos protected steel columns; 8" × 6" × 35 lbs. "H" beam; Protection: sprayed on asbestos paste to 2" cover over column.	90 tons	4 hrs.			7	2, 3, 4	4

For SI: 1 inch = 25.4 mm, 1 pound = 0.004448 kN, 1 ton = 8.896 kN.

Notes:

1. Passed 2 hour fire exposure (Grade "C" - British).
2. Passed hose stream test.
3. Passed reload test.
4. Passed 4 hour fire exposure test.

**TABLE 2.5.4.4
STEEL COLUMNS—MISCELLANEOUS ENCASEMENTS
MINIMUM DIMENSION 12" TO LESS THAN 14"**

ITEM CODE	MINIMUM DIMENSION	CONSTRUCTION DETAILS	PERFORMANCE		REFERENCE NUMBER			NOTES	REC. HOURS
			LOAD	TIME	PRE-BMS-92	BMS-92	POST-BMS-92		
C-12-SM-1	12"	12" × 14 ¹ / ₄ " cement and asbestos protected columns; 8" × 6" × 35 lbs. "H" beam; Protection: fill of asbestos packing pieces 1" thick 1'3" o.c.; cover of 2" molded asbestos inner layer; 1" molded asbestos outer layer; held in position by 16 SWG nichrome wire ties; wash of refractory cement on outer surface.	86 tons	4 hrs. 43 min.			7	1, 2, 3	4 ² / ₃

For SI: 1 inch = 25.4 mm, 1 pound = 0.004448 kN, 1 ton = 8.896 kN.

Notes:

1. Passed 4 hour fire exposure (Grade "B" - British).
2. Passed hose stream test.
3. Passed reload test.

**SECTION III
FLOOR/CEILING ASSEMBLIES**

**FIGURE 3.1
FLOOR/CEILING ASSEMBLIES—REINFORCED CONCRETE**

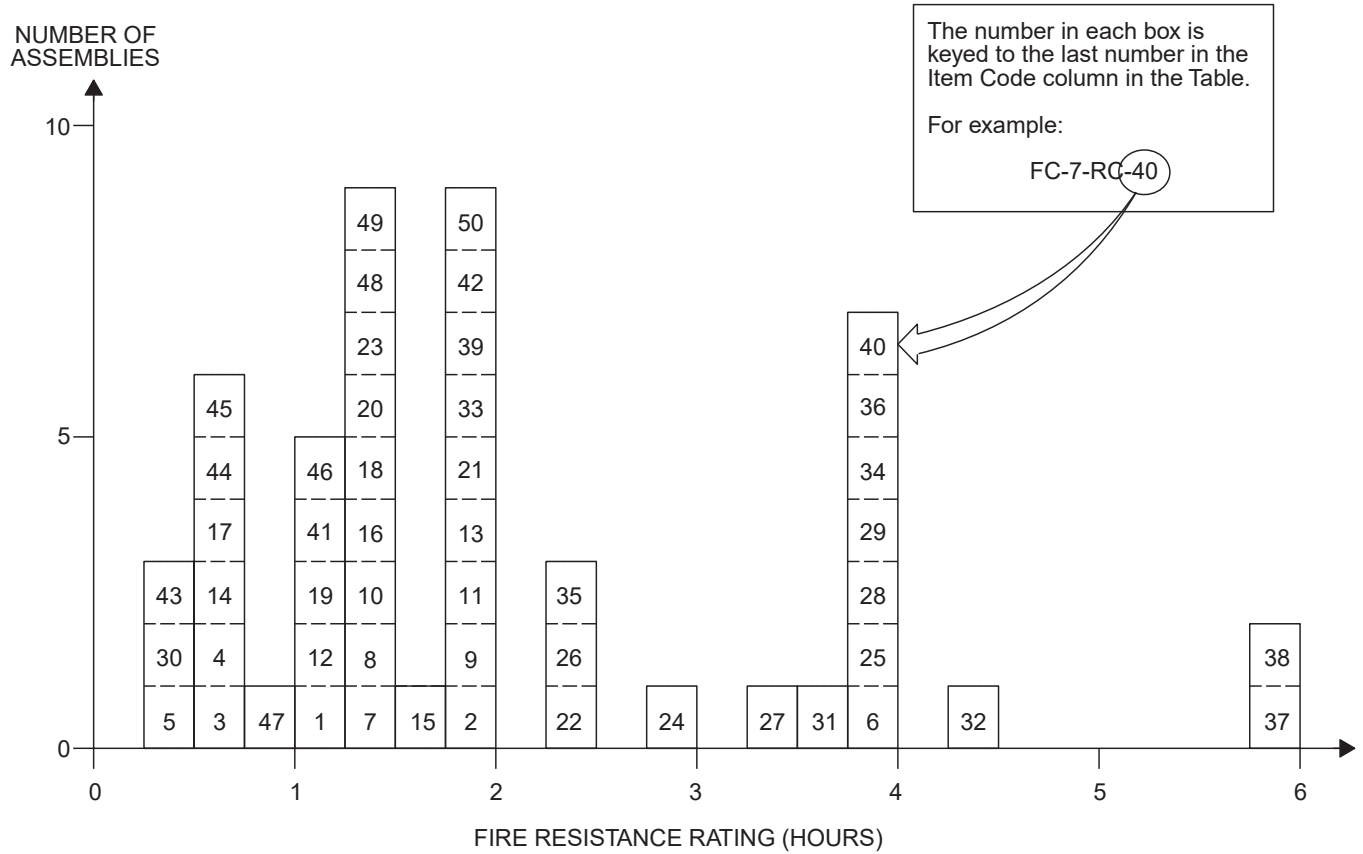

**TABLE 3.1
FLOOR/CEILING ASSEMBLIES—REINFORCED CONCRETE**

ITEM CODE	ASSEMBLY THICKNESS	CONSTRUCTION DETAILS	PERFORMANCE		REFERENCE NUMBER			NOTES	REC. HOURS
			LOAD	TIME	PRE-BMS-92	BMS-92	POST-BMS-92		
F/C-3-RC-1	3 ³ / ₄ "	3 ³ / ₄ " thick floor; 3 ¹ / ₄ " (5475 psi) concrete deck; 1/2" plaster under deck; 3/8" main reinforcement bars at 5 1/2" pitch with 7/8" concrete cover; 3/8" main reinforcement bars at 4 1/2" pitch perpendicular with 1/2" concrete cover; 13'1" span restrained.	195 psf	24 min.			7	1, 2	1/3
F/C-3-RC-2	3 1/4"	3 1/4" deep (3540 psi) concrete deck; 3/8" main reinforcement bars at 5 1/2" pitch with 7/8" cover; 3/8" main reinforcement bars at 4 1/2" pitch perpendicular with 1/2" cover; 13'1" span restrained.	195 psf	2 hrs.			7	1, 3, 4	2

(continued)

**TABLE 3.1—continued
FLOOR/CEILING ASSEMBLIES—REINFORCED CONCRETE**

ITEM CODE	ASSEMBLY THICKNESS	CONSTRUCTION DETAILS	PERFORMANCE		REFERENCE NUMBER			NOTES	REC. HOURS
			LOAD	TIME	PRE-BMS-92	BMS-92	POST-BMS-92		
F/C-3-RC-3	3 ¹ / ₄ "	3 ¹ / ₄ " deep (4175 psi) concrete deck; 3 ³ / ₈ " main reinforcement bars at 5 ¹ / ₂ " pitch with 7 ⁷ / ₈ " cover; 3 ³ / ₈ " main reinforcement bars at 4 ¹ / ₂ " pitch perpendicular with 1 ¹ / ₂ " cover; 13'1" span restrained.	195 psf	31 min.			7	1, 5	1/2
F/C-3-RC-4	3 ¹ / ₄ "	3 ¹ / ₄ " deep (4355 psi) concrete deck; 3 ³ / ₈ " main reinforcement bars at 5 ¹ / ₂ " pitch with 7 ⁷ / ₈ " cover; 3 ³ / ₈ " main reinforcement bars at 4 ¹ / ₂ " pitch perpendicular with 1 ¹ / ₂ " cover; 13'1" span restrained.	195 psf	41 min.			7	1, 5, 6	1/2
F/C-3-RC-5	3 ¹ / ₄ "	3 ¹ / ₄ " thick (3800 psi) concrete deck; 3 ³ / ₈ " main reinforcement bars at 5 ¹ / ₂ " pitch with 7 ⁷ / ₈ " cover; 3 ³ / ₈ " main reinforcement bars at 4 ¹ / ₂ " pitch perpendicular with 1 ¹ / ₂ " cover; 13'1" span restrained.	195 psf	1 hr. 5 min.			7	1, 5	1
F/C-4-RC-6	4 ¹ / ₄ "	4 ¹ / ₄ " thick; 3 ¹ / ₄ " (4000 psi) concrete deck; 1" sprayed asbestos lower surface; 3 ³ / ₈ " main reinforcement bars at 5 ⁷ / ₈ " pitch with 7 ⁷ / ₈ " concrete cover; 3 ³ / ₈ " main reinforcement bars at 4 ¹ / ₂ " pitch perpendicular with 1 ¹ / ₂ " concrete cover; 13'1" span restrained.	195 psf	4 hrs.			7	1, 7	4
F/C-4-RC-7	4"	4" (5025 psi) concrete deck; 1 ¹ / ₄ " reinforcement bars at 7 ¹ / ₂ " pitch with 3 ³ / ₄ " cover; 3 ³ / ₈ " main reinforcement bars at 3 ³ / ₄ " pitch perpendicular with 1 ¹ / ₂ " cover; 13'1" span restrained.	140 psf	1 hr. 16 min.			7	1, 2	1 ¹ / ₄
F/C-4-RC-8	4"	4" thick (4905 psi) deck; 1 ¹ / ₄ " reinforcement bars at 7 ¹ / ₂ " pitch with 7 ⁷ / ₈ " cover; 3 ³ / ₈ " main reinforcement bars at 3 ³ / ₄ " pitch perpendicular with 1 ¹ / ₂ " cover; 13'1" span restrained.	100 psf	1 hr. 23 min.			7	1, 2	1 ¹ / ₃
F/C-4-RC-9	4"	4" deep (4370 psi); 1 ¹ / ₄ " reinforcement bars at 6" pitch with 3 ³ / ₄ " cover; 1 ¹ / ₄ " main reinforcement bars at 4" pitch perpendicular with 1 ¹ / ₂ " cover; 13'1" span restrained.	150 psf	2 hrs.			7	1, 3	2
F/C-4-RC-10	4"	4" thick (5140 psi) deck; 1 ¹ / ₄ " reinforcement bars at 7 ¹ / ₂ " pitch with 7 ⁷ / ₈ " cover; 3 ³ / ₈ " main reinforcement bars at 3 ³ / ₄ " pitch perpendicular with 1 ¹ / ₂ " cover; 13'1" span restrained.	140 psf	1 hr. 16 min.			7	1, 5	1 ¹ / ₄
F/C-4-RC-11	4"	4" thick (4000 psi) concrete deck; 3" x 1 ¹ / ₂ " x 4 lbs. R.S.J.; 2'6" C.R.S.; flush with top surface; 4" x 6" x 13 SWG mesh reinforcement 1" from bottom of slab; 6'6" span restrained.	150 psf	2 hrs.			7	1, 3	2

(continued)

**TABLE 3.1—continued
FLOOR/CEILING ASSEMBLIES—REINFORCED CONCRETE**

ITEM CODE	ASSEMBLY THICKNESS	CONSTRUCTION DETAILS	PERFORMANCE		REFERENCE NUMBER			NOTES	REC. HOURS
			LOAD	TIME	PRE-BMS-92	BMS-92	POST-BMS-92		
F/C-4-RC-12	4"	4" deep (2380 psi) concrete deck; 3" × 1½" × 4 lbs. R.S.J.; 2'6" C.R.S.; flush with top surface; 4" × 6" x 13 SWG mesh reinforcement 1" from bottom surface; 6'6" span restrained.	150 psf	1 hr. 3 min.			7	1, 2	1
F/C-4-RC-13	4½"	4½" thick (5200 psi) deck; ¼" reinforcement bars at 7¼" pitch with ⅞" cover; ⅜" main reinforcement bars at 3¾" pitch perpendicular with ½" cover; 13'1" span restrained.	140 psf	2 hrs.			7	1, 3	2
F/C-4-RC-14	4½"	4½" deep (2525 psi) concrete deck; ¼" reinforcement bars at 7½" pitch with ⅞" cover; ⅜" main reinforcement bars at 3¾" pitch perpendicular with ½" cover; 13'1" span restrained.	150 psf	42 min.			7	1, 5	⅔
F/C-4-RC-15	4½"	4½" deep (4830 psi) concrete deck; 1½" × No. 15 gauge wire mesh; ⅜" reinforcement bars at 15" pitch with 1" cover; ½" main reinforcement bars at 6" pitch perpendicular with ½" cover; 12' span simply supported.	75 psf	1 hr. 32 min.			7	1, 8	1½
F/C-4-RC-16	4½"	4½" deep (4595 psi) concrete deck; ¼" reinforcement bars at 7½" pitch with ⅞" cover; ⅜" main reinforcement bars at 3½" pitch perpendicular with ½" cover; 12' span simply supported.	75 psf	1 hr. 20 min.			7	1, 8	1⅓
F/C-4-RC-17	4½"	4½" deep (3625 psi) concrete deck; ¼" reinforcement bars at 7½" pitch with ⅞" cover; ⅜" main reinforcement bars at 3½" pitch perpendicular with ½" cover; 12' span simply supported.	75 psf	35 min.			7	1, 8	½
F/C-4-RC-18	4½"	4½" deep (4410 psi) concrete deck; ¼" reinforcement bars at 7½" pitch with ⅞" cover; ⅜" main reinforcement bars at 3½" pitch perpendicular with ½" cover; 12' span simply supported.	85 psf	1 hr. 27 min.			7	1, 8	1⅓
F/C-4-RC-19	4½"	4½" deep (4850 psi) deck; ⅜" reinforcement bars at 15" pitch with 1" cover; ½" main reinforcement bars at 6" pitch perpendicular with ½" cover; 12' span simply supported.	75 psf	2 hrs. 15 min.			7	1, 9	1¼
F/C-4-RC-20	4½"	4½" deep (3610 psi) deck; ¼" reinforcement bars at 7½" pitch with ⅞" cover; ⅜" main reinforcement bars at 3½" pitch perpendicular with ½" cover; 12' span simply supported.	75 psf	1 hr. 22 min.			7	1, 8	1⅓

(continued)

**TABLE 3.1—continued
FLOOR/CEILING ASSEMBLIES—REINFORCED CONCRETE**

ITEM CODE	ASSEMBLY THICKNESS	CONSTRUCTION DETAILS	PERFORMANCE		REFERENCE NUMBER			NOTES	REC. HOURS
			LOAD	TIME	PRE-BMS-92	BMS-92	POST-BMS-92		
F/C-5-RC-21	5"	5" deep; 4½" (5830 psi) concrete deck; ½" plaster finish bottom of slab; ¼" reinforcement bars at 7½" pitch with ⅞" cover; ⅜" main reinforcement bars at 3½" pitch perpendicular with ½" cover; 12' span simply supported.	69 psf	2 hrs.			7	1, 3	2
F/C-5-RC-22	5"	4½" (5290 psi) concrete deck; ½" plaster finish bottom of slab; ¼" reinforcement bars at 7½" pitch with ⅞" cover; ⅜" main reinforcement bars at 3½" pitch perpendicular with ½" cover; 12' span simply supported.	No load	2 hrs. 28 min.			7	1, 10, 11	2¼
F/C-5-RC-23	5"	5" (3020 psi) concrete deck; 3" × 1½" × 4 lbs. R.S.J.; 2' C.R.S. with 1" cover on bottom and top flanges; 8' span restrained.	172 psf	1 hr. 24 min.			7	1, 2, 12	1½
F/C-5-RC-24	5½"	5" (5180 psi) concrete deck; ½" retarded plaster underneath slab; ¼" reinforcement bars at 7½" pitch with 1⅜" cover; ⅜" main reinforcement bars at 3½" pitch perpendicular with 1" cover; 12' span simply supported.	60 psf	2 hrs. 48 min.			7	1, 10	2¾
F/C-6-RC-25	6"	6" deep (4800 psi) concrete deck; ¼" reinforcement bars at 7½" pitch with ⅞" cover; ⅜" main reinforcement bars at 3½" pitch perpendicular with ⅞" cover; 13'1" span restrained.	195 psf	4 hrs.			7	1, 7	4
F/C-6-RC-26	6"	6" (4650 psi) concrete deck; ¼" reinforcement bars at 7½" pitch with ⅞" cover; ⅜" main reinforcement bars at 3½" pitch perpendicular with ½" cover; 13'1" span restrained.	195 psf	2 hrs. 23 min.			7	1, 2	2¼
F/C-6-RC-27	6"	6" deep (6050 psi) concrete deck; ¼" reinforcement bars at 7½" pitch ⅞" cover; ⅜" reinforcement bars at 3½" pitch perpendicular with ½" cover; 13'1" span restrained.	195 psf	3 hrs. 30 min.			7	1, 10	3½
F/C-6-RC-28	6"	6" deep (5180 psi) concrete deck; ¼" reinforcement bars at 8" pitch ¾" cover; ¼" reinforcement bars at 5½" pitch perpendicular with ½" cover; 13'1" span restrained.	150 psf	4 hrs.			7	1, 7	4
F/C-6-RC-29	6"	6" thick (4180 psi) concrete deck; 4" × 3" × 10 lbs. R.S.J.; 2' 6" C.R.S. with 1" cover on both top and bottom flanges; 13'1" span restrained.	160 psf	3 hrs. 48 min.			7	1, 10	3¾
F/C-6-RC-30	6"	6" thick (3720 psi) concrete deck; 4" × 3" × 10 lbs. R.S.J.; 2' 6" C.R.S. with 1" cover on both top and bottom flanges; 12' span simply supported.	115 psf	29 min.			7	1, 5, 13	¼

(continued)

**TABLE 3.1—continued
FLOOR/CEILING ASSEMBLIES—REINFORCED CONCRETE**

ITEM CODE	ASSEMBLY THICKNESS	CONSTRUCTION DETAILS	PERFORMANCE		REFERENCE NUMBER			NOTES	REC. HOURS
			LOAD	TIME	PRE-BMS-92	BMS-92	POST-BMS-92		
F/C-6-RC-31	6"	6" deep (3450 psi) concrete deck; 4" × 1 ³ / ₄ " × 5 lbs. R.S.J.; 2' 6" C.R.S. with 1" cover on both top and bottom flanges; 12' span simply supported.	25 psf	3 hrs. 35 min.			7	1, 2	3 ¹ / ₂
F/C-6-RC-32	6"	6" deep (4460 psi) concrete deck; 4" × 1 ³ / ₄ " × 5 lbs. R.S.J.; 2' C.R.S.; with 1" cover on both top and bottom flanges; 12' span simply supported.	60 psf	4 hrs. 30 min.			7	1, 10	4 ¹ / ₂
F/C-6-RC-33	6"	6" deep (4360 psi) concrete deck; 4" × 1 ³ / ₄ " × 5 lbs. R.S.J.; 2' C.R.S.; with 1" cover on both top and bottom flanges; 13'1" span restrained.	60 psf	2 hrs.			7	1, 3	2
F/C-6-RC-34	6 ¹ / ₄ "	6 ¹ / ₄ " thick; 4 ³ / ₄ " (5120 psi) concrete core; 1" T&G board flooring; 1/2" plaster undercoat; 4" × 3" × 10 lbs. R.S.J.; 3' C.R.S. flush with top surface concrete; 12' span simply supported; 2" × 1'3" clinker concrete insert.	100 psf	4 hrs.			7	1, 7	4
F/C-6-RC-35	6 ¹ / ₄ "	4 ³ / ₄ " (3600 psi) concrete core; 1" T&G board flooring; 1/2" plaster undercoat; 4" × 3" × 10 lbs. R.S.J.; 3' C.R.S.; flush with top surface concrete; 12' span simply supported; 2" × 1'3" clinker concrete insert.	100 psf	2 hrs. 30 min.			7	1, 5	2 ¹ / ₂
F/C-6-RC-36	6 ¹ / ₄ "	4 ³ / ₄ " (2800 psi) concrete core; 1" T&G board flooring; 1/2" plaster undercoat; 4" × 3" × 10 lbs. R.S.J.; 3' C.R.S.; flush with top surface concrete; 12" span simply supported; 2" × 1'3" clinker concrete insert.	80 psf	4 hrs.			7	1, 7	4
F/C-7-RC-37	7"	(3640 psi) concrete deck; 1/4" reinforcement bars at 6" pitch with 1 1/2" cover; 1/4" reinforcement bars at 5" pitch perpendicular with 1 1/2" cover; 13'1" span restrained.	169 psf	6 hrs.			7	1, 14	6
F/C-7-RC-38	7"	(4060 psi) concrete deck; 4" × 3" × 10 lbs. R.S.J.; 2' 6" C.R.S. with 1 1/2" cover on both top and bottom flanges; 4" × 6" × 13 SWG mesh reinforcement 1 1/2" from bottom of slab; 13'1" span restrained.	175 psf	6 hrs.			7	1, 14	6
F/C-7-RC-39	7 ¹ / ₄ "	5 ³ / ₄ " (4010 psi) concrete core; 1" T&G board flooring; 1/2" plaster undercoat; 4" × 3" × 10 lbs. R.S.J.; 2' 6" C.R.S.; 1" down from top surface of concrete; 12' simply supported span; 2" × 1' 3" clinker concrete insert.	95 psf	2 hrs.			7	1, 3	2
F/C-7-RC-40	7 ¹ / ₄ "	5 ³ / ₄ " (3220 psi) concrete core; 1" T&G flooring; 1/2" plaster undercoat; 4" × 3" × 10 lbs. R.S.J.; 2'6" C.R.S.; 1" down from top surface of concrete; 12' simply supported span; 2" × 1'3" clinker concrete insert.	95 psf	4 hrs.			7	1, 7	4

(continued)

TABLE 3.1—continued
FLOOR/CEILING ASSEMBLIES—REINFORCED CONCRETE

ITEM CODE	ASSEMBLY THICKNESS	CONSTRUCTION DETAILS	PERFORMANCE		REFERENCE NUMBER			NOTES	REC. HOURS
			LOAD	TIME	PRE-BMS-92	BMS-92	POST-BMS-92		
F/C-7-RC-41	10" (2 1/4" Slab)	Ribbed floor, see Note 15 for details; slab 2 1/2" deep (3020 psi); 1/4" reinforcement bars at 6" pitch with 3/4" cover; beams 7 1/2" deep x 5" wide; 24" C.R.S.; 5/8" reinforcement bars two rows 1/2" vertically apart with 1" cover; 13'1" span restricted.	195 psf	1 hr. 4 min.			7	1, 2, 15	1
F/C-5-RC-42	5 1/2"	Composite ribbed concrete slab assembly; see Note 17 for details.	See Note 16	2 hrs.			43	16, 17	2
F/C-3-RC-43	3"	2500 psi concrete; 5/8" cover; fully restrained at test.	See Note 16	30 min.			43	16	1/2
F/C-3-RC-44	3"	2000 psi concrete; 5/8" cover; free or partial restraint at test.	See Note 16	45 min.			43	16	3/4
F/C-4-RC-45	4"	2500 psi concrete; 5/8" cover; fully restrained at test.	See Note 16	40 min.			43	16	2/3
F/C-4-RC-46	4"	2000 psi concrete; 3/4" cover; free or partial restraint at test.	See Note 16	1 hr. 15 min.			43	16	1 1/4
F/C-5-RC-47	5"	2500 psi concrete; 3/4" cover; fully restrained at test.	See Note 16	1 hr.			43	16	1
F/C-5-RC-48	5"	2000 psi concrete; 3/4" cover; free or partial restraint at test.	See Note 16	1 hr. 30 min.			43	16	1 1/2
F/C-6-RC-49	6"	2500 psi concrete; 1" cover; fully restrained at test.	See Note 16	1 hr. 30 min.			43	16	1 1/2
F/C-6-RC-50	6"	2000 psi concrete; 1" cover; free or partial restraint at test.	See Note 16	2 hrs.			43	16	2

For SI: 1 inch = 25.4 mm, 1 foot = 305 mm, 1 pound per square inch = 0.00689 MPa, 1 pound per square foot = 47.9 N/m².

Notes :

1. British test.
2. Failure mode—local back face temperature rise.
3. Tested for Grade "C" (2 hour) fire resistance
4. Collapse imminent following hose stream.
5. Failure mode—flame thru.
6. Void formed with explosive force and report.
7. Achieved Grade "B" (4 hour) fire resistance (British).
8. Failure mode—collapse.
9. Test was run to 2 hours, but specimen was partially supported by the furnace at 1 1/4 hours.
10. Failure mode—average back face temperature.
11. Recommended endurance for nonload bearing performance only.
12. Floor maintained load bearing ability to 2 hours at which point test was terminated.
13. Test was run to 3 hours at which time failure mode 2 (above) was reached in spite of crack formation at 29 minutes.
14. Tested for Grade "A" (6 hour) fire resistance.
- 15.

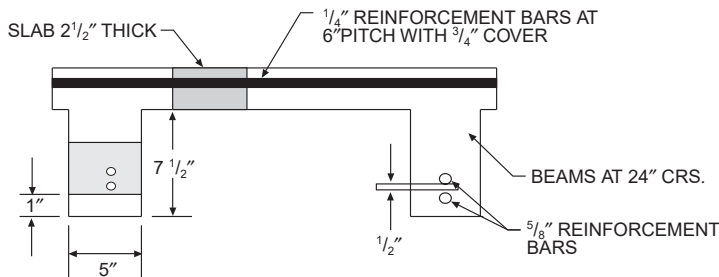

16. Load unspecified.
17. Total assembly thickness 5 1/2 inches. Three-inch thick blocks of molded excelsior bonded with portland cement used as inserts with 2 1/2-inch cover (concrete) above blocks and 3/4-inch gypsum plaster below. Nine-inch wide ribs containing reinforcing steel of unspecified size interrupted 20-inch wide segments of slab composite (i.e., plaster, excelsior blocks, concrete cover).

**FIGURE 3.2
FLOOR/CEILING ASSEMBLIES—STEEL STRUCTURAL ELEMENTS**

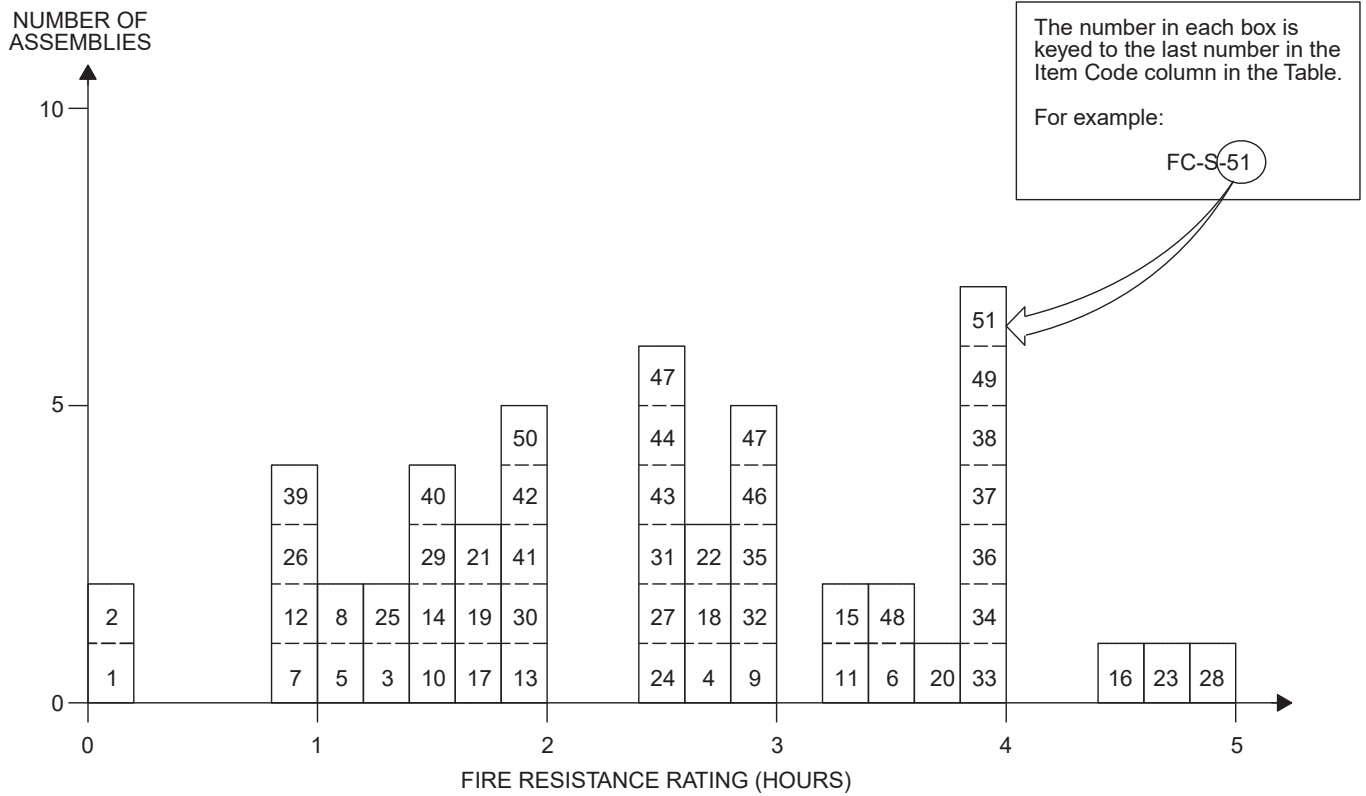

**TABLE 3.2
FLOOR/CEILING ASSEMBLIES—STEEL STRUCTURAL ELEMENTS**

ITEM CODE	MEMBRANE THICKNESS	CONSTRUCTION DETAILS	PERFORMANCE		REFERENCE NUMBER			NOTES	REC. HOURS
			LOAD	TIME	PRE-BMS-92	BMS-92	POST-BMS-92		
F/C-S-1	0"	10' × 13'6" ; S.J. 103 - 24" o.c.; Deck: 2" concrete; Membrane: none.	145 psf	7 min.			3	1, 2, 3, 8	0
F/C-S-2	0"	10' × 13'6" ; S.J. 103 - 24" o.c.; Deck: 2" concrete; Membrane: none	145 psf	7 min.			3	1, 2, 3, 8	0
F/C-S-3	1/2"	10' × 13' 6" ; S.J. 103 - 24" o.c.; Deck: 2" concrete 1:2:4; Membrane: furring 12" o.c.; Clips A, B, G; No extra reinforcement; 1/2" plaster - 1.5:2.5.	145 psf	1 hr. 15 min.			3	2, 3, 8	1 1/4
F/C-S-4	1/2"	10' × 13' 6" ; S.J. 103 - 24" o.c.; Deck: 2" concrete 1:2:4; Membrane: furring 16" o.c.; Clips D, E, F, G; Diagonal wire reinforcement; 1/2" plaster - 1.5:2.5.	145 psf	2 hrs. 46 min.			3	3, 8	2 3/4
F/C-S-5	1/2"	10' × 13'6" ; S.J. 103 - 24" o.c.; Deck: 2" concrete 1:2:4; Membrane: furring 16" o.c.; Clips A, B, G; No extra reinforcement; 1/2" plaster - 1.5:2.5.	145 psf	1 hr. 4 min.			3	2, 3, 8	1
F/C-S-6	1/2"	10' × 13'6" ; S.J. 103 - 24" o.c.; Deck: 2" concrete 1:2:4; Membrane: furring 16" o.c.; Clips D, E, F, G; Hexagonal mesh reinforcement; 1/2" plaster.	145 psf	3 hrs. 28 min.			3	2, 3, 8	2 1/3

(continued)

**TABLE 3.2—continued
FLOOR/CEILING ASSEMBLIES—STEEL STRUCTURAL ELEMENTS**

ITEM CODE	MEMBRANE THICKNESS	CONSTRUCTION DETAILS	PERFORMANCE		REFERENCE NUMBER			NOTES	REC. HOURS
			LOAD	TIME	PRE-BMS-92	BMS-92	POST-BMS-92		
F/C-S-7	1/2"	10' × 13'6" ; S.J. 103 - 24" o.c.; Deck: 4 lbs. rib lath; 6" × 6" - 10 × 10 ga. reinforcement; 2" deck gravel concrete; Membrane: furring 16" o.c.; Clips C, E; Reinforcement: none; 1/2" plaster - 1.5:2.5 mill mix.	N/A	55 min.			3	5, 8	3/4
F/C-S-8	1/2"	Spec. 9' × 4'4"; S.J. 103 bar joists - 18" o.c.; Deck: 4 lbs. rib lath base; 6" × 6" - 10 × 10 ga. reinforcement; 2" deck 1:2:4 gravel concrete; Membrane: furring, 3/4" C.R.S., 16" o.c.; Clips C, E; Reinforcement: none; 1/2" plaster - 1.5:2.5 mill mix.	300 psf	1 hr. 10 min.			3	2, 3, 8	1
F/C-S-9	5/8"	10' × 13'6"; S.J. 103 - 24" o.c.; Deck: 2" concrete 1:2:4; Membrane: furring 12" o.c.; Clips A, B, G; Extra "A" clips reinforcement; 5/8" plaster - 1.5:2; 1.5:3.	145 psf	3 hrs.			3	6, 8	3
F/C-S-10	5/8"	18' × 13'6" ; Joists, S.J. 103 - 24" o.c.; Deck: 4 lbs. rib lath; 6" × 6" - 10 × 10 ga. reinforcement; 2" deck 1:2:3.5 gravel concrete; Membrane: furring, spacing 16" o.c.; Clips C, E; Reinforcement: none; 3/8" plaster - 1.5:2.5 mill mix.	145 psf	1 hr. 25 min.			3	2, 3, 8	1 1/3
F/C-S-11	5/8"	10' × 13'6"; S.J. 103 - 24" o.c.; Deck: 2" concrete 1:2:4; Membrane: furring 12" o.c.; Clips D, E, F, G; Diagonal wire reinforcement; 5/8" plaster - 1.5:2; 0.5:3.	145 psf	3 hrs. 15 min.			3	2, 4, 8	3 1/4
F/C-S-12	5/8"	10' × 13'6"; Joists, S.J. 103 - 24" o.c.; Deck: 3.4 lbs. rib lath; 6" × 6" - 10 × 10 ga. reinforcement; 2" deck 1:2:4 gravel concrete; Membrane: furring 16" o.c.; Clips D, E, F, G; Reinforcement: none; 3/8" plaster - 1.5:2.5.	145 psf	1 hr.			3	7, 8	1
F/C-S-13	3/4"	Spec. 9' × 4'4"; S.J. 103 - 18" o.c.; Deck: 4 lbs. rib lath; 6" × 6" - 10 × 10 ga. reinforcement; 2" deck 1:2:4 gravel concrete; Membrane: furring, 3/4" C.R.S., 16" o.c.; Clips C, E; Reinforcement: none; 3/4" plaster - 1.5:2.5 mill mix.	300 psf	1 hr. 56 min.			3	3, 8	1 3/4
F/C-S-14	7/8"	Floor finish: 1" concrete; plate cont. weld; 4" - 7.7 lbs. "I" beams; Ceiling: 1/4" rods 12" o.c.; 7/8" gypsum sand plaster.	105 psf	1 hr. 35 min.			6	2, 4, 9, 10	1 1/2
F/C-S-15	1"	Floor finish: 1 1/2" L.W. concrete; 1/2" limestone cement; plate cont. weld; 5" - 10 lbs. "I" beams; Ceiling: 1/4" rods 12" o.c. tack welded to beams metal lath; 1" P. C. plaster.	165 psf	3 hrs. 20 min.			6	4, 9, 11	3 1/3
F/C-S-16	1"	10' × 13'6" ; S.J. 103 - 24" o.c.; Deck: 2" concrete 1:2:4; Membrane: furring 12" o.c.; Clips D, E, F, G; Hexagonal mesh reinforcement; 1" thick plaster - 1.5:2; 1.5:3.	145 psf	4 hrs. 26 min.			3	2, 4, 8	4 1/3
F/C-S-17	1"	10' × 13'6" ; Joists - S.J. 103 - 24" o.c.; Deck: 3.4 lbs. rib lath; 6" × 6" - 10 × 10 ga. reinforcement; 2" deck 1:2:4 gravel concrete; Membrane: furring 16" o.c.; Clips D, E, F, G; 1" plaster.	145 psf	1 hr. 42 min.			3	2, 4, 8	1 2/3

(continued)

**TABLE 3.2—continued
FLOOR/CEILING ASSEMBLIES—STEEL STRUCTURAL ELEMENTS**

ITEM CODE	MEMBRANE THICKNESS	CONSTRUCTION DETAILS	PERFORMANCE		REFERENCE NUMBER			NOTES	REC. HOURS
			LOAD	TIME	PRE-BMS-92	BMS-92	POST-BMS-92		
F/C-S-18	1 1/8"	10' x 13'6"; S. J. 103 - 24" o.c.; Deck: 2" concrete 1:2:4; Membrane: furring 12" o.c.; Clips C, E, F, G; Diagonal wire reinforcement; 1 1/8" plaster.	145 psf	2 hrs. 44 min.			3	2, 4, 8	2 2/3
F/C-S-19	1 1/8"	10' x 13'6"; Joists - S.J. 103 - 24" o.c.; Deck: 1 1/2" gypsum concrete over; 1/2" gypsum board; Membrane: furring 12" o.c.; Clips D, E, F, G; 1 1/8" plaster - 1.5:2; 1.5:3.	145 psf	1 hr. 40 min.			3	2, 3, 8	1 2/3
F/C-S-20	1 1/8"	2 1/2" cinder concrete; 1/2" topping; plate 6" welds 12" o.c.; 5" - 18.9 lbs. "H" center; 5" - 10 lbs. "I" ends; 1" channels 18" o.c.; 1 1/8" gypsum sand plaster.	150 psf	3 hrs. 43 min.			6	2, 4, 9, 11	3 2/3
F/C-S-21	1 1/4"	10' x 13'6"; Joists - S.J. 103 - 24" o.c.; Deck: 1 1/2" gypsum concrete over; 1/2" gypsum board base; Membrane: furring 12" o.c.; Clips D, E, F, G; 1 1/4" plaster - 1.5:2; 1.5:3.	145 psf	1 hr. 48 min.			3	2, 3, 8	1 2/3
F/C-S-22	1 1/4"	Floor finish: 1 1/2" limestone concrete; 1/2" sand cement topping; plate to beams 3 1/2"; 12" o.c. welded; 5" - 10 lbs. "I" beams; 1" channels 18" o.c.; 1 1/4" wood fiber gypsum sand plaster on metal lath.	292 psf	2 hrs. 45 min.			6	2, 4, 9, 10	2 3/4
F/C-S-23	1 1/2"	2 1/2" L.W. (gas exp.) concrete; Deck: 1/2" topping; plate 6 1/4" welds 12" o.c.; Beams: 5" - 18.9 lbs. "H" center; 5" - 10 lbs. "I" ends; Membrane: 1" channels 18" o.c.; 1 1/2" gypsum sand plaster.	150 psf	4 hrs. 42 min.			6	2, 4, 9	4 2/3
F/C-S-24	1 1/2"	Floor finish: 1 1/2" limestone concrete; 1/2" cement topping; plate 3 1/2" - 12" o.c. welded; 5" - 10 lbs. "I" beams; Ceiling: 1" channels 18" o.c.; 1 1/2" gypsum plaster.	292 psf	2 hrs. 34 min.			6	2, 4, 9, 10	2 1/2
F/C-S-25	1 1/2"	Floor finish: 1 1/2" gravel concrete on exp. metal; plate cont. weld; 4" - 7.7 lbs. "I" beams; Ceiling: 1/4" rods 12" o.c. welded to beams; 1 1/2" fiber gypsum sand plaster.	70 psf	1 hr. 24 min.			6	2, 4, 9, 10	1 1/3
F/C-S-26	2 1/2"	Floor finish: bare plate; 6 1/4" welding - 12" o.c.; 5" - 18.9 lbs. "H" girders (inner); 5" - 10 lbs "I" girders (two outer); 1" channels 18" o.c.; 2" reinforced gypsum tile; 1/2" gypsum sand plaster.	122 psf	1 hr.			6	7, 9, 11	1
F/C-S-27	2 1/2"	Floor finish: 2" gravel concrete; plate to beams 3 1/2" - 12" o.c. welded; 4" - 7.7 lbs. "I" beams; 2" gypsum ceiling tiles; 1/2" 1:3 gypsum sand plaster.	105 psf	2 hrs. 31 min.			6	2, 4, 9, 10	2 1/2
F/C-S-28	2 1/2"	Floor finish: 1 1/2" gravel concrete; 1/2" gypsum asphalt; plate continuous weld; 4" - 7.7 lbs. "I" beams; 12" - 31.8 lbs. "I" beams - girder at 5' from one end; 1" channels 18" o.c.; 2" reinforcement gypsum tile; 1/2" 1:3 gypsum sand plaster.	200 psf	4 hrs. 55 min.			6	2, 4, 9, 11	4 2/3

(continued)

TABLE 3.2—continued
FLOOR/CEILING ASSEMBLIES—STEEL STRUCTURAL ELEMENTS

ITEM CODE	MEMBRANE THICKNESS	CONSTRUCTION DETAILS	PERFORMANCE		REFERENCE NUMBER			NOTES	REC. HOURS
			LOAD	TIME	PRE-BMS-92	BMS-92	POST-BMS-92		
F/C-S-29	3/4"	Floor: 2" reinforced concrete or 2" precast reinforced gypsum tile; Ceiling: 3/4" portland cement-sand plaster 1:2 for scratch coat and 1:3 for brown coat with 15 lbs. hydrated lime and 3 lbs. of short asbestos fiber bag per cement or 3/4" sanded gypsum plaster 1:2 for scratch coat and 1:3 for brown coat.	See Note 12	1 hr. 30 min.		1		12, 13, 14	1 1/2
F/C-S-30	3/4"	Floor: 2 1/4" reinforced concrete or 2" reinforced gypsum tile; the latter with 1/4" mortar finish; Ceiling: 3/4" sanded gypsum plaster; 1:2 for scratch coat and 1:3 for brown coat.	See Note 12	2 hrs.		1		12, 13, 14	2
F/C-S-31	3/4"	Floor: 2 1/2" reinforced concrete or 2" reinforced gypsum tile; the latter with 1/4" mortar finish; Ceiling: 1" neat gypsum plaster or 3/4" gypsum-vermiculite plaster, ratio of gypsum to fine vermiculite 2:1 to 3:1.	See Note 12	2 hrs. 30 min.		1		12, 13, 14	2 1/2
F/C-S-32	3/4"	Floor: 2 1/2" reinforced concrete or 2" reinforced gypsum tile; the latter with 1/2" mortar finish; Ceiling: 1" neat gypsum plaster or 3/4" gypsum-vermiculite plaster, ratio of gypsum to fine vermiculite 2:1 to 3:1.	See Note 12	3 hrs.		1		12, 13, 14	3
F/C-S-33	1"	Floor: 2 1/2" reinforced concrete or 2" reinforced gypsum slabs; the latter with 1/2" mortar finish; Ceiling: 1" gypsum-vermiculite plaster applied on metal lath and ratio 2:1 to 3:1 gypsum to vermiculite by weight.	See Note 12	4 hrs.		1		12, 13, 14	4
F/C-S-34	2 1/2"	Floor: 2" reinforced concrete or 2" precast reinforced portland cement concrete or gypsum slabs; precast slabs to be finished with 1/4" mortar top coat; Ceiling: 2" precast reinforced gypsum tile, anchored into beams with metal ties or clips and covered with 1/2" 1:3 sanded gypsum plaster.	See Note 12	4 hrs.		1		12, 13, 14	4
F/C-S-35	1"	Floor: 1:3:6 portland cement, sand and gravel concrete applied directly to the top of steel units and 1 1/2" thick at top of cells, plus 1/2" 1:2 1/2" cement-sand finish, total thickness at top of cells, 2"; Ceiling: 1" neat gypsum plaster, back of lath 2" or more from underside of cellular steel.	See Note 15	3 hrs.		1		15, 16, 17, 18	3
F/C-S-36	1"	Floor: same as F/C-S-35; Ceiling: 1" gypsum-vermiculite plaster (ratio of gypsum to vermiculite 2:1 to 3:1), the back of lath 2" or more from under-side of cellular steel.	See Note 15	4 hrs.		1		15, 16, 17, 18	4
F/C-S-37	1"	Floor: same as F/C-S-35; Ceiling: 1" neat gypsum plaster; back of lath 9" or more from underside of cellular steel.	See Note 15	4 hrs.		1		15, 16, 17, 18	4
F/C-S-38	1"	Floor: same as F/C-S-35; Ceiling: 1" gypsum-vermiculite plaster (ratio of gypsum to vermiculite 2:1 to 3:1), the back of lath being 9" or more from underside of cellular steel.	See Note 15	5 hrs.		1		15, 16, 17, 18	5

(continued)

TABLE 3.2—continued
FLOOR/CEILING ASSEMBLIES—STEEL STRUCTURAL ELEMENTS

ITEM CODE	MEMBRANE THICKNESS	CONSTRUCTION DETAILS	PERFORMANCE		REFERENCE NUMBER			NOTES	REC. HOURS
			LOAD	TIME	PRE-BMS-92	BMS-92	POST-BMS-92		
F/C-S-39	3/4"	Floor: asbestos paper 14 lbs./100 ft. ² cemented to steel deck with waterproof linoleum cement, wood screeds and 7/8" wood floor; Ceiling: 3/4" sanded gypsum plaster 1:2 for scratch coat and 1:3 for brown coat.	See Note 19	1 hr.		1		19, 20, 21, 22	1
F/C-S-40	3/4"	Floor: 1 1/2", 1:2:4 portland cement concrete; Ceiling: 3/4" sanded gypsum plaster 1:2 for scratch coat and 1:3 for brown coat.	See Note 19	1 hr. 30 min.		1		19, 20, 21, 22	1 1/2
F/C-S-41	3/4"	Floor: 2", 1:2:4 portland cement concrete; Ceiling: 3/4" sanded gypsum plaster, 1:2 for scratch coat and 1:3 for brown coat.	See Note 19	2 hrs.		1		19, 20, 21, 22	2
F/C-S-42	1"	Floor: 2", 1:2:4 portland cement concrete; Ceiling: 1" portland cement-sand plaster with 10 lbs. of hydrated lime for @ bag of cement 1:2 for scratch coat and 1:2 1/2" for brown coat.	See Note 19	2 hrs.		1		19, 20, 21, 22	2
F/C-S-43	1 1/2"	Floor: 2", 1:2:4 portland cement concrete; Ceiling: 1 1/2", 1:2 sanded gypsum plaster on ribbed metal lath.	See Note 19	2 hrs. 30 min.		1		19, 20, 21, 22	2 1/2
F/C-S-44	1 1/8"	Floor: 2", 1:2:4 portland cement concrete; Ceiling: 1 1/8", 1:1 sanded gypsum plaster.	See Note 19	2 hrs. 30 min.		1		19, 20, 21, 22	2 1/2
F/C-S-45	1"	Floor: 2 1/2", 1:2:4 portland cement concrete; Ceiling: 1", 1:2 sanded gypsum plaster.	See Note 19	2 hrs. 30 min.		1		19, 20, 21, 22	2 1/2
F/C-S-46	3/4"	Floor: 2 1/2", 1:2:4 portland cement concrete; Ceiling: 1" neat gypsum plaster or 3/4" gypsum-vermiculite plaster, ratio of gypsum to vermiculite 2:1 to 3:1.	See Note 19	3 hrs.		1		19, 20, 21, 22	3
F/C-S-47	1 1/8"	Floor: 2 1/2", 1:2:4 portland cement, sand and cinder concrete plus 1/2", 1:2 1/2" cement-sand finish; total thickness 3"; Ceiling: 1 1/8", 1:1 sanded gypsum plaster.	See Note 19	3 hrs.		1		19, 20, 21, 22	3
F/C-S-48	1 1/8"	Floor: 2 1/2", gas expanded portland cement-sand concrete plus 1/2", 1:2.5 cement-sand finish; total thickness 3"; Ceiling: 1 1/8", 1:1 sanded gypsum plaster.	See Note 19	3 hrs. 30 min.		1		19, 20, 21, 22	3 1/2
F/C-S-49	1"	Floor: 2 1/2", 1:2:4 portland cement concrete; Ceiling: 1" gypsum- vermiculite plaster; ratio of gypsum to vermiculite 2:1 to 3:1.	See Note 19	4 hrs.		1		19, 20, 21, 22	4
F/C-S-50	2 1/2"	Floor: 2", 1:2:4 portland cement concrete; Ceiling: 2" interlocking gypsum tile supported on upper face of lower flanges of beams, 1/2" 1:3 sanded gypsum plaster.	See Note 19	2 hrs.		1		19, 20, 21, 22	2
F/C-S-51	2 1/2"	Floor: 2", 1:2:4 portland cement concrete; Ceiling: 2" precast metal reinforced gypsum tile, 1/2" 1:3 sanded gypsum plaster (tile clipped to channels which are clipped to lower flanges of beams).	See Note 19	4 hrs.		1		19, 20, 21, 22	4

For SI: 1 inch = 25.4 mm, 1 foot = 305 mm, 1 pound per square inch = 0.00689 MPa, 1 pound per square foot = 47.9 N/m².

Notes:

1. No protective membrane over structural steel.
2. Performance time indicates first endpoint reached only several tests were continued to points where other failures occurred.
3. Load failure.

(continued)

TABLE 3.2—continued
FLOOR/CEILING ASSEMBLIES—STEEL STRUCTURAL ELEMENTS

4. Thermal failure.
5. This is an estimated time to load bearing failure. The same joist and deck specimen was used for a later test with different membrane protection.
6. Test stopped at 3 hours to reuse specimen; no endpoint reached.
7. Test stopped at 1 hour to reuse specimen; no endpoint reached.
8. All plaster used = gypsum.
9. Specimen size - 18 feet by 13 $\frac{1}{2}$ inches. Floor deck - base material - $\frac{1}{4}$ -inch by 18-foot steel plate welded to "I" beams.
10. "I" beams - 24 inches o.c.
11. "I" beams - 48 inches o.c.
12. Apply to open web joists, pressed steel joists or rolled steel beams, which are not stressed beyond 18,000 lbs./in.² in flexure for open-web pressed or light rolled joists, and 20,000 lbs./in.² for American standard or heavier rolled beams.
13. Ratio of weight of portland cement to fine and coarse aggregates combined for floor slabs shall not be less than 1:6 $\frac{1}{2}$.
14. Plaster for ceiling shall be applied on metal lath which shall be tied to supports to give the equivalent of single No. 18 gage steel wires 5 inches o.c.
15. Load: maximum fiber stress in steel not to exceed 16,000 psi.
16. Prefabricated units 2 feet wide with length equal to the span, composed of two pieces of No. 18 gage formed steel welded together to give four longitudinal cells.
17. Depth not less than 3 inches and distance between cells no less than 2 inches.
18. Ceiling: metal lath tied to furring channels secured to runner channels hung from cellular steel.
19. Load: rolled steel supporting beams and steel plate base shall not be stressed beyond 20,000 psi in flexure. Formed steel (with wide upper flange) construction shall not be stressed beyond 16,000 psi.
20. Some type of expanded metal or woven wire shall be embedded to prevent cracking in concrete flooring.
21. Ceiling plaster shall be metal lath wired to rods or channels which are clipped or welded to steel construction. Lath shall be no smaller than 18 gage steel wire and not more than 7 inches o.c.
22. The securing rods or channels shall be at least as effective as single $\frac{3}{16}$ -inch rods with 1-inch of their length bent over the lower flanges of beams with the rods or channels tied to this clip with 14 gage iron wire.

**FIGURE 3.3
FLOOR/CEILING ASSEMBLIES—WOOD JOIST**

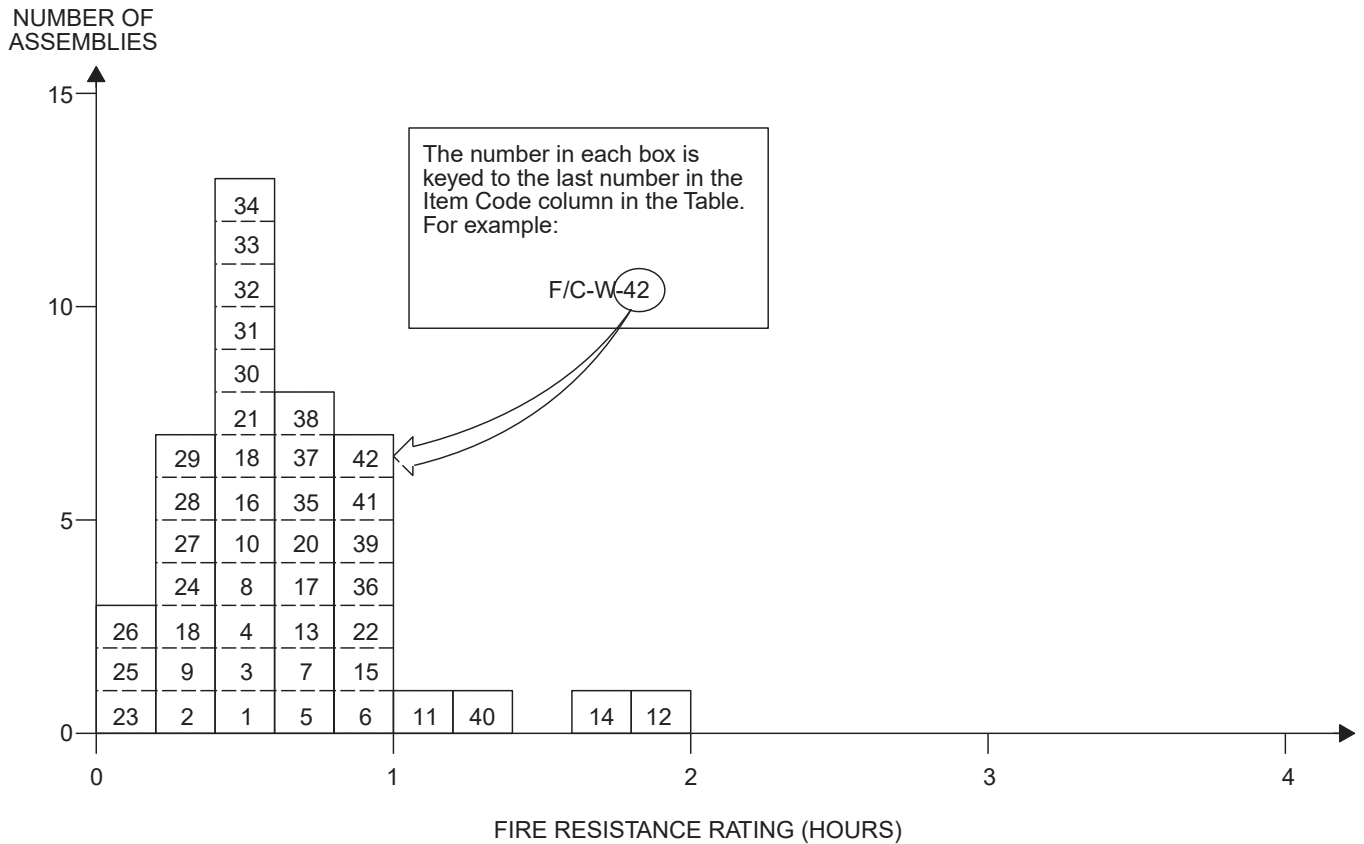

**TABLE 3.3
FLOOR/CEILING ASSEMBLIES—WOOD JOIST**

ITEM CODE	MEMBRANE THICKNESS	CONSTRUCTION DETAILS	PERFORMANCE		REFERENCE NUMBER			NOTES	REC. HOURS
			LOAD	TIME	PRE-BMS-92	BMS-92	POST-BMS-92		
F/C-W-1	3/8"	12' clear span - 2" x 9" wood joists; 18" o.c.; Deck: 1" T&G; Filler: 3" of ashes on 1/2" boards nailed to joist sides 2" from bottom; 2" air space; Membrane: 3/8" gypsum board.	60 psf	36 min.			7	1, 2	1/2
F/C-W-2	1/2"	12' clear span - 2" x 7" joists; 15" o.c.; Deck: 1" nominal lumber; Membrane: 1/2" fiber board.	60 psf	22 min.			7	1, 2, 3	1/4
F/C-W-3	1/2"	12' clear span - 2" x 7" wood joists; 16" o.c.; 2" x 1 1/2" bridging at center; Deck: 1" T&G; Membrane: 1/2" fiber board; 2 coats "distemper" paint.	30 psf	28 min.			7	1, 3, 15	1/3
F/C-W-4	3/16"	12' clear span - 2" x 7" wood joists; 16" o.c.; 2" x 1 1/2" bridging at center span; Deck: 1" nominal lumber; Membrane: 1/2" fiber board under 3/16" gypsum plaster.	30 psf	32 min.			7	1, 2	1/2
F/C-W-5	5/8"	As per previous F/C-W-4 except membrane is 5/8" lime plaster.	70 psf	48 min.			7	1, 2	3/4
F/C-W-6	5/8"	As per previous F/C-W-5 except membrane is 5/8" gypsum plaster on 22 gage 3/8" metal lath.	70 psf	49 min.			7	1, 2	3/4

(continued)

**TABLE 3.3—continued
FLOOR/CEILING ASSEMBLIES—WOOD JOIST**

ITEM CODE	MEMBRANE THICKNESS	CONSTRUCTION DETAILS	PERFORMANCE		REFERENCE NUMBER			NOTES	REC. HOURS
			LOAD	TIME	PRE-BMS-92	BMS-92	POST-BMS-92		
F/C-W-7	1/2"	As per previous F/C-W-6 except membrane is 1/2" fiber board under 1/2" gypsum plaster.	60 psf	43 min.			7	1, 2, 3	2/3
F/C-W-8	1/2"	As per previous F/C-W-7 except membrane is 1/2" gypsum board.	60 psf	33 min.			7	1, 2, 3	1/2
F/C-W-9	9/16"	12' clear span - 2" x 7" wood joists; 15" o.c.; 2" x 1 1/2" bridging at center; Deck: 1" nominal lumber; Membrane: 3/8" gypsum board; 3/16" gypsum plaster.	60 psf	24 min.			7	1, 2, 3	1/3
F/C-W-10	5/8"	As per F/C-W-9 except membrane is 5/8" gypsum plaster on wood lath.	60 psf	27 min.			7	1, 2, 3	1/3
F/C-W-11	7/8"	12' clear span - 2" x 9" wood joists; 15" o.c.; 2" x 1 1/2" bridging at center span; Deck: 1" T&G; Membrane: original ceiling joists have 3/8" plaster on wood lath; 4" metal hangers attached below joists creating 15" chases filled with mineral wool and closed with 7/8" plaster (gypsum) on 3/8" S.W.M. metal lath to form new ceiling surface.	75 psf	1 hr. 10 min.			7	1, 2	1
F/C-W-12	7/8"	12' clear span - 2" x 9" wood joists; 15" o.c.; 2" x 1 1/2" bridging at center; Deck: 1" T&G; Membrane: 3" mineral wood below joists; 3" hangers to channel below joists; 7/8" gypsum plaster on metal lath attached to channels.	75 psf	2 hrs.			7	1, 4	2
F/C-W-13	7/8"	12' clear span - 2" x 9" wood joists; 16" o.c.; 2" x 1 1/2" bridging at center span; Deck: 1" T&G on 1" bottoms on 3/4" glass wool strips on 3/4" gypsum board nailed to joists; Membrane: 3/4" glass wool strips on joists; 3/8" perforated gypsum lath; 1/2" gypsum plaster.	60 psf	41 min.			7	1, 3	2/3
F/C-W-14	7/8"	12' clear span - 2" x 9" wood joists; 15" o.c.; Deck: 1" T&G; Membrane: 3" foam concrete in cavity on 1/2" boards nailed to joists; wood lath nailed to 1" x 1 1/4" straps 14 o.c. across joists; 7/8" gypsum plaster.	60 psf	1 hr. 40 min.			7	1, 5	1 2/3
F/C-W-15	7/8"	12' clear span - 2" x 9" wood joists; 18" o.c.; Deck: 1" T&G; Membrane: 2" foam concrete on 1/2" boards nailed to joist sides 2" from joist bottom; 2" air space; 1" x 1 1/4" wood straps 14" o.c. across joists; 7/8" lime plaster on wood lath.	60 psf	53 min.			7	1, 2	3/4
F/C-W-16	7/8"	12' clear span - 2" x 9" wood joists; Deck: 1" T&G; Membrane: 3" ashes on 1/2" boards nailed to joist sides 2" from joist bottom; 2" air space; 1" x 1 1/4" wood straps 14" o.c. ; 7/8" gypsum plaster on wood lath.	60 psf	28 min.			7	1, 2	1/3
F/C-W-17	7/8"	As per previous F/C-W-16 but with lime plaster mix.	60 psf	41 min.			7	1, 2	2/3
F/C-W-18	7/8"	12' clear span - 2" x 9" wood joists; 18" o.c.; 2" x 1 1/2" bridging at center; Deck: 1" T&G; Membrane: 7/8" gypsum plaster on wood lath.	60 psf	36 min.			7	1, 2	1/2
F/C-W-19	7/8"	As per previous F/C-W-18 except with lime plaster membrane and deck is 1" nominal boards (plain edge).	60 psf	19 min.			7	1, 2	1/4

(continued)

**TABLE 3.3—continued
FLOOR/CEILING ASSEMBLIES—WOOD JOIST**

ITEM CODE	MEMBRANE THICKNESS	CONSTRUCTION DETAILS	PERFORMANCE		REFERENCE NUMBER			NOTES	REC. HOURS
			LOAD	TIME	PRE-BMS-92	BMS-92	POST-BMS-92		
F/C-W-20	7/8"	As per F/C-W-19, except deck is 1" T&G boards.	60 psf	43 min.			7	1, 2	2/3
F/C-W-21	1"	12' clear span - 2" × 9" wood joists; 16" o.c.; 2" × 1 1/2" bridging at center; Deck: 1" T&G; Membrane: 3/8" gypsum base board; 5/8" gypsum plaster.	70 psf	29 min.			7	1, 2	1/3
F/C-W-22	1 1/8"	12' clear span - 2" × 9" wood joists; 16" o.c.; 2" × 2" wood bridging at center; Deck: 1" T&G; Membrane: hangers, channel with 3/8" gypsum baseboard affixed under 3/4" gypsum plaster.	60 psf	1 hr.			7	1, 2, 3	1
F/C-W-23	3/8"	Deck: 1" nominal lumber; Joists: 2" × 7"; 15" o.c.; Membrane: 3/8" plasterboard with plaster skim coat.	60 psf	11 1/2 min.			12	2, 6	1/6
F/C-W-24	1/2"	Deck: 1" T&G lumber; Joists: 2" × 9"; 16" o.c.; Membrane: 1/2" plasterboard.	60 psf	18 min.			12	2, 7	1/4
F/C-W-25	1/2"	Deck: 1" T&G lumber; Joists: 2" × 7"; 16" o.c.; Membrane: 1/2" fiber insulation board.	30 psf	8 min.			12	2, 8	2/15
F/C-W-26	1/2"	Deck: 1" nominal lumber; Joists: 2" × 7"; 15" o.c.; Membrane: 1/2" fiber insulation board.	60 psf	8 min.			12	2, 9	2/15
F/C-W-27	5/8"	Deck: 1" nominal lumber; Joists: 2" × 7"; 15" o.c.; Membrane: 5/8" gypsum plaster on wood lath.	60 psf	17 min.			12	2, 10	1/4
F/C-W-28	5/8"	Deck: 1" T&G lumber; Joists: 2" × 9"; 16" o.c.; Membrane: 1/2" fiber insulation board; 1/2" plaster.	60 psf	20 min.			12	2, 11	1/3
F/C-W-29	No Membrane	Exposed wood joists.	See Note 13	15 min.		1		1, 12, 13, 14	1/4
F/C-W-30	3/8"	Gypsum wallboard: 3/8" or 1/2" with 1 1/2" No. 15 gage nails with 3/16" heads spaced 6" centers with asbestos paper applied with paperhangers' paste and finished with casein paint.	See Note 13	25 min.		1		1, 12, 13, 14	1/2
F/C-W-31	1/2"	Gypsum wallboard: 1/2" with 1 3/4" No. 12 gage nails with 1/2" heads, 6" o.c., and finished with casein paint.	See Note 13	25 min.		1		1, 12, 13, 14	1/2
F/C-W-32	1/2"	Gypsum wallboard: 1/2" with 1 1/2" No. 12 gage nails with 1/2" heads, 18" o.c., with asbestos paper applied with paperhangers' paste and secured with 1 1/2" No. 15 gage nails with 3/16" heads and finished with casein paint; combined nail spacing 6" o.c.	See Note 13	30 min.		1		1, 12, 13, 14	1/2
F/C-W-33	3/8"	Gypsum wallboard: two layers 3/8" secured with 1 1/2" No. 15 gage nails with 3/8" heads, 6" o.c.	See Note 13	30 min.		1		1, 12, 13, 14	1/2
F/C-W-34	1/2"	Perforated gypsum lath: 3/8", plastered with 1 1/8" No. 13 gage nails with 5/16" heads, 4" o.c.; 1/2" sanded gypsum plaster.	See Note 13	30 min.		1		1, 12, 13, 14	1/2
F/C-W-35	1/2"	Same as F/C-W-34, except with 1 1/8" No. 13 gage nails with 3/8" heads, 4" o.c.	See Note 13	45 min.		1		1, 12, 13, 14	3/4

(continued)

**TABLE 3.3—continued
FLOOR/CEILING ASSEMBLIES—WOOD JOIST**

ITEM CODE	MEMBRANE THICKNESS	CONSTRUCTION DETAILS	PERFORMANCE		REFERENCE NUMBER			NOTES	REC. HOURS
			LOAD	TIME	PRE-BMS-92	BMS-92	POST-BMS-92		
F/C-W-36	1/2"	Perforated gypsum lath: 3/8", nailed with 1 1/8" No. 13 gage nails with 3/8" heads, 4" o.c.; joints covered with 3" strips of metal lath with 1 3/4" No. 12 nails with 1/2" heads, 5" o.c.; 1/2" sanded gypsum plaster.	See Note 13	1 hr.		1		1, 12, 13, 14	1
F/C-W-37	1/2"	Gypsum lath: 3/8" and lower layer of 3/8" perforated gypsum lath nailed with 1 3/4" No. 13 nails with 5/16" heads, 4" o.c.; 1/2" sanded gypsum plaster or 1/2" portland cement plaster.	See Note 13	45 min.		1		1, 12, 13, 14	3/4
F/C-W-38	3/4"	Metal lath: nailed with 1 1/4" No. 11 nails with 3/8" heads or 6d common driven 1" and bent over, 6" o.c.; 3/4" sanded gypsum plaster.	See Note 13	45 min.		1		1, 12, 13, 14	3/4
F/C-W-39	3/4"	Same as F/C-W-38, except nailed with 1 1/2" No. 11 barbed roof nails with 7/16" heads, 6" o.c.	See Note 13	1 hr.		1		1, 12, 13, 14	1
F/C-W-40	3/4"	Same as F/C-W-38, except with lath nailed to joists with additional supports for lath 27" o.c.; attached to alternate joists and consisting of two nails driven 1 1/4", 2" above bottom on opposite sides of the joists, one loop of No. 18 wire slipped over each nail; the ends twisted together below lath.	See Note 13	1 hr. 15 min.		1		1, 12, 13, 14	1 1/4
F/C-W-41	3/4"	Metal lath: nailed with 1 1/2" No. 11 barbed roof nails with 7/16" heads, 6 o.c., with 3/4" portland cement plaster for scratch coat and 1:3 for brown coat, 3 lbs. of asbestos fiber and 15 lbs. of hydrated lime/94 lbs. bag of cement.	See Note 13	1 hr.		1		1, 12, 13, 14	1
F/C-W-42	3/4"	Metal lath: nailed with 8d, No. 11 1/2 gage barbed box nails, 2 1/2" driven, 1 1/4" on slant and bent over, 6" o.c.; 3/4" sanded gypsum plaster, 1:2 for scratch coat and 1:3 for below coat.	See Note 13	1 hr.		1		1, 12, 13, 14	1

For SI: 1 inch = 25.4 mm, 1 foot = 305 mm, 1 pound per square inch = 0.00689 MPa, 1 pound per square foot = 47.9 N/m².

Notes:

1. Thickness indicates thickness of first membrane protection on ceiling surface.
2. Failure mode—flame thru.
3. Failure mode—collapse.
4. No endpoint reached at termination of test.
5. Failure imminent—test terminated.
6. Joist failure—11.5 minutes; flame thru—13 minutes; collapse—24 minutes.
7. Joist failure—17 minutes; flame thru—18 minutes; collapse—33 minutes.
8. Joist failure—18 minutes; flame thru—8 minutes; collapse—30 minutes.
9. Joist failure—12 minutes; flame thru—8 minutes; collapse—22 minutes.
10. Joist failure—11 minutes; flame thru—17 minutes; collapse—27 minutes.
11. Joist failure—17 minutes; flame thru—20 minutes; collapse—43 minutes.
12. Joists: 2-inch by 10-inch southern pine or Douglas fir; No. 1 common or better. Subfloor: 3/4-inch wood sheathing diaphragm of asbestos paper, and finish of tongue-and-groove wood flooring.
13. Loadings: not more than 1,000 psi maximum fiber stress in joists.
14. Perforations in gypsum lath are to be not less than 3/4-inch diameter with one perforation for not more than 16/in.² diameter.
15. "Distemper" is a British term for a water-based paint such as white wash or calcimine.

FIGURE 3.4
FLOOR/CEILING ASSEMBLIES—HOLLOW CLAY TILE WITH REINFORCED CONCRETE

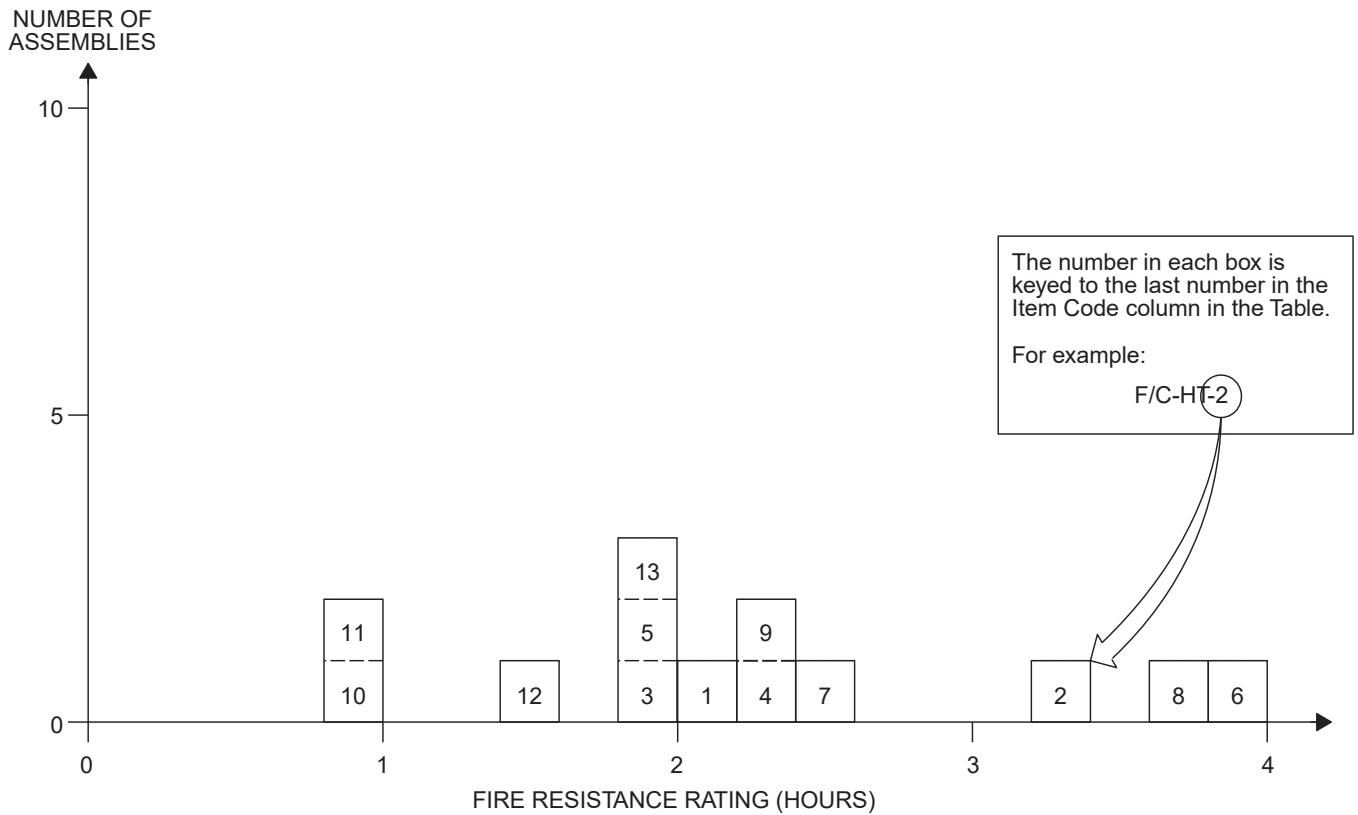

TABLE 3.4
FLOOR/CEILING ASSEMBLIES—HOLLOW CLAY TILE WITH REINFORCED CONCRETE

ITEM CODE	ASSEMBLY THICKNESS	CONSTRUCTION DETAILS	PERFORMANCE		REFERENCE NUMBER			NOTES	REC. HOURS
			LOAD	TIME	PRE-BMS-92	BMS-92	POST-BMS-92		
F/C-HT-1	6"	Cover: 1½" concrete (6080 psi); three cell hollow clay tiles, 12" × 12" × 4"; 3¼" concrete between tiles including two ½" rebars with ¾" concrete cover; ½" plaster cover, lower.	75 psf	2 hrs. 7 min.			7	1, 2, 3	2
F/C-HT-2	6"	Cover: 1½" concrete (5840 psi); three cell hollow clay tiles, 12" × 12" × 4"; 3¼" concrete between tiles including two ½" rebars each with ½" concrete cover and ⅝" filler tiles between hollow tiles; ½" plaster cover, lower.	61 psf	3 hrs. 23 min.			7	3, 4, 6	3⅓
F/C-HT-3	6"	Cover: 1½" concrete (6280 psi); three cell hollow clay tiles, 12" × 12" × 4"; 3¼" concrete between tiles including two ½" rebars with ½" cover; ½" plaster cover, lower.	122 psf	2 hrs.			7	1, 3, 5, 8	2
F/C-HT-4	6"	Cover: 1½" concrete (6280 psi); three cell hollow clay tiles, 12" × 12" × 4"; 3¼" concrete between tiles including two ½" rebars with ¾" cover; ½" plaster cover, lower.	115 psf	2 hrs. 23 min.			7	1, 3, 7	2⅓
F/C-HT-5	6"	Cover: 1½" concrete (6470 psi); three cell hollow clay tiles, 12" × 12" × 4"; 3¼" concrete between tiles including two ½" rebars with ½" cover; ½" plaster cover, lower.	122 psf	2 hrs.			7	1, 3, 5, 8	2

(continued)

TABLE 3.4—continued
FLOOR/CEILING ASSEMBLIES—HOLLOW CLAY TILE WITH REINFORCED CONCRETE

ITEM CODE	ASSEMBLY THICKNESS	CONSTRUCTION DETAILS	PERFORMANCE		REFERENCE NUMBER			NOTES	REC. HOURS
			LOAD	TIME	PRE-BMS-92	BMS-92	POST-BMS-92		
F/C-HT-6	8"	Floor cover: 1 1/2" gravel cement (4300 psi); three cell, 12" x 12" x 6"; 3 1/2" space between tiles including two 1/2" rebars with 1" cover from concrete bottom; 1/2" plaster cover, lower.	165 psf	4 hrs.			7	1, 3, 9, 10	4
F/C-HT-7	9" (nom.)	Deck: 7/8" T&G on 2" x 1 1/2" bottoms (18" o.c.) 1 1/2" concrete cover (4600 psi); three cell hollow clay tiles, 12" x 12" x 4"; 3" concrete between tiles including one 3/4" rebar 3/4" from tile bottom; 3/4" plaster cover.	95 psf	2 hrs. 26 min.			7	4, 11, 12, 13	2 1/3
F/C-HT-8	9" (nom.)	Deck: 7/8" T&G on 2" x 1 1/2" bottoms (18" o.c.) 1 1/2" concrete cover (3850 psi); three cell hollow clay tiles, 12" x 12" x 4"; 3" concrete between tiles including one 3/4" rebar 3/4" from tile bottoms; 1/2" plaster cover.	95 psf	3 hrs. 28 min.			7	4, 11, 12, 13	
F/C-HT-9	9" (nom.)	Deck: 7/8" T&G on 2" x 1 1/2" bottoms (18" o.c.) 1 1/2" concrete cover (4200 psi); three cell hollow clay tiles, 12" x 12" x 4"; 3" concrete between tiles including one 3/4" rebar 3/4" from tile bottoms; 1/2" plaster cover.	95 psf	2 hrs. 14 min.			7	3, 5, 8, 11	
F/C-HT-10	5 1/2"	Fire clay tile (4" thick); 1 1/2" concrete cover; for general details, see Note 15.	See Note 14	1 hr.			43	15	1
F/C-HT-11	8"	Fire clay tile (6" thick); 2" cover.	See Note 14	1 hr.			43	15	1
F/C-HT-12	5 1/2"	Fire clay tile (4" thick); 1 1/2" cover; 5/8" gypsum plaster, lower.	See Note 14	1 hr. 30 min.			43	15	1 1/2
F/C-HT-13	8"	Fire clay tile (6" thick); 2" cover; 5/8" gypsum plaster, lower.	See Note 14	2 hrs.			43	15	1 1/2

For SI: 1 inch = 25.4 mm, 1 foot = 305 mm, 1 pound per square inch = 0.00689 MPa, 1 pound per square foot = 47.9 N/m².

Notes:

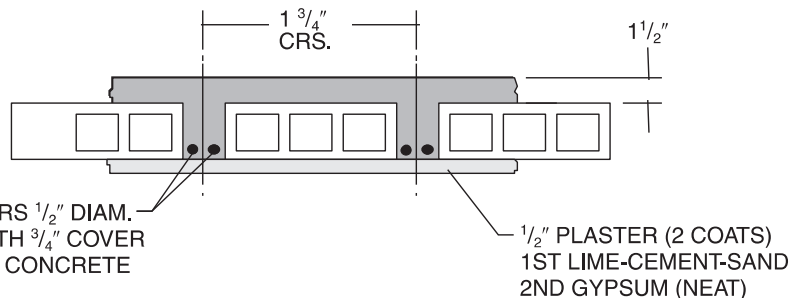

1. A generalized cross section of this floor type follows:
2. Failure mode - structural.
3. Plaster: base coat—lime-cement-sand; top coat—gypsum (neat).

(continued)

TABLE 3.4—continued
FLOOR/CEILING ASSEMBLIES—HOLLOW CLAY TILE WITH REINFORCED CONCRETE

4. Failure mode—collapse.
5. Test stopped before any endpoints were reached.
6. A generalized cross section of this floor type follows:

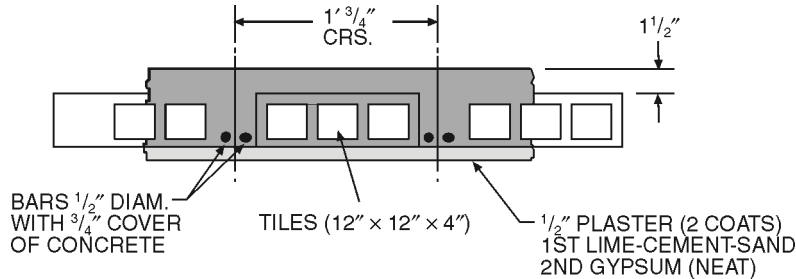

7. Failure mode—thermal—back face temperature rise.
8. Passed hose stream test.
9. Failed hose stream test.

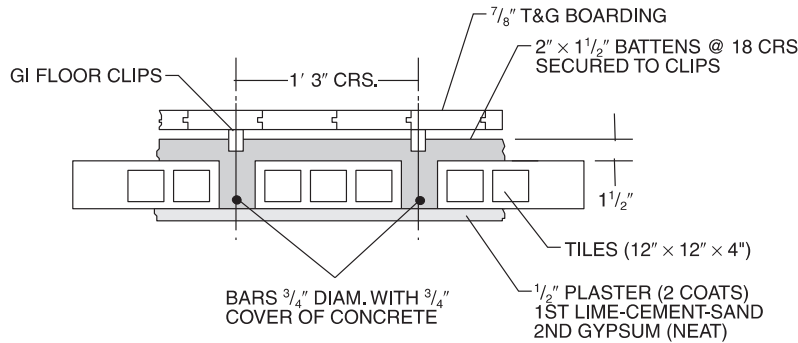

10. Test stopped at 4 hours before any endpoints were reached.
11. A generalized cross section of this floor type follows:
12. Plaster: base coat—retarded hemihydrate gypsum-sand; second coat—neat gypsum.
13. Concrete in Item 7 is P.C. based but with crushed brick aggregates while in Item 8 river sand and river gravels are used with the P.C.
14. Load - unspecified.
15. The 12-inch by 12-inch fire-clay tiles were laid end to end in rows spaced 2 1/2 inches or 4 inches apart. The reinforcing steel was placed between these rows and the concrete cast around them and over the tile to form the structural floor.

**SECTION IV
BEAMS**

**TABLE 4.1.1
REINFORCED CONCRETE BEAMS
DEPTH 10" TO LESS THAN 12"**

ITEM CODE	DEPTH	CONSTRUCTION DETAILS	PERFORMANCE		REFERENCE NUMBER			NOTES	REC. HOURS
			LOAD	TIME	PRE-BMS-92	BMS-92	POST-BMS-92		
B-11-RC-1	11"	24" wide × 11" deep reinforced concrete "T" beam (3290 psi); Details: see Note 5 figure.	8.8 tons	4 hrs. 2 min.			7	1, 2, 14	4
B-10-RC-2	10"	24" wide × 10" deep reinforced concrete "T" beam (4370 psi); Details: see Note 6 figure.	8.8 tons	1 hr. 53 min.			7	1, 3	1 ³ / ₄
B-10-RC-3	10 ¹ / ₂ "	24" wide × 10 ¹ / ₂ " deep reinforced concrete "T" beam (4450 psi); Details: see Note 7 figure.	8.8 tons	2 hrs. 40 min.			7	1, 3	2 ² / ₃
B-11-RC-4	11"	24" wide × 11" deep reinforced concrete "T" beam (2400 psi); Details: see Note 8 figure.	8.8 tons	3 hrs. 32 min.			7	1, 3, 14	3 ¹ / ₂
B-11-RC-5	11"	24" wide × 11" deep reinforced concrete "T" beam (4250 psi); Details: see Note 9 figure.	8.8 tons	3 hrs. 3 min.			7	1, 3, 14	3
B-11-RC-6	11"	Concrete flange: 4" deep × 2' wide (4895 psi) concrete; Concrete beam: 7" deep × 6 ¹ / ₂ " wide beam; "I" beam reinforcement; 10" × 4 ¹ / ₂ " × 25 lbs. R.S.J.; 1" cover on flanges; Flange reinforcement: 3/8" diameter bars at 6" pitch parallel to "T"; 1/4" diameter bars perpendicular to "T"; Beam reinforcement: 4" × 6" wire mesh No. 13 SWG; Span: 11' restrained; Details: see Note 10 figure.	10 tons	6 hrs.			7	1, 4	6
B-11-RC-7	11"	Concrete flange: 6" deep × 1' 6 ¹ / ₂ " wide (3525 psi) concrete; Concrete beam: 5" deep × 8" wide precast concrete blocks 8 ³ / ₄ " long; "I" beam reinforcement; 7" × 4" × 16 lbs. R.S.J.; 2" cover on bottom; 1 ¹ / ₂ " cover on top; Flange reinforcement: two rows 1/2" diameter rods parallel to "T"; Beam reinforcement: 1/8" wire mesh perpendicular to 1" ; Span: 1' 3" simply supported; Details: see Note 11 figure.	3.9 tons	4 hrs.			7	1, 2	4
B-11-RC-8	11"	Concrete flange: 4" deep × 2' wide (3525 psi) concrete; Concrete beam 7" deep × 4 ¹ / ₂ " wide; (scaled from drawing); "I" beam reinforcement; 10" × 4 ¹ / ₂ " × 25 lbs. R.S.J.; no concrete cover on bottom; Flange reinforcement: 3/8" diameter bars at 6 pitch parallel to "T"; 1/4" diameter bars perpendicular to "T"; Span: 11' restricted.	10 tons	4 hrs.			7	1, 2, 12	4
B-11-RC-9	11 ¹ / ₂ "	24" wide × 11 ¹ / ₂ " deep reinforced concrete "T" beam (4390 psi); Details: see Note 12 figure.	8.8 tons	3 hrs. 24 min.			7	1, 3	3 ¹ / ₃

For SI: 1 inch = 25.4 mm, 1 foot = 305 mm, 1 pound = 0.004448 kN, 1 pound per square inch = 0.00689 MPa, 1 ton = 8.896 kN.

Notes:

1. Load concentrated at mid span.
2. Achieved 4 hour performance (Class "B," British).
3. Failure mode—collapse.
4. Achieved 6 hour performance (Class "A," British).

(continued)

**TABLE 4.1.1—continued
REINFORCED CONCRETE BEAMS
DEPTH 10" TO LESS THAN 12"**

5.

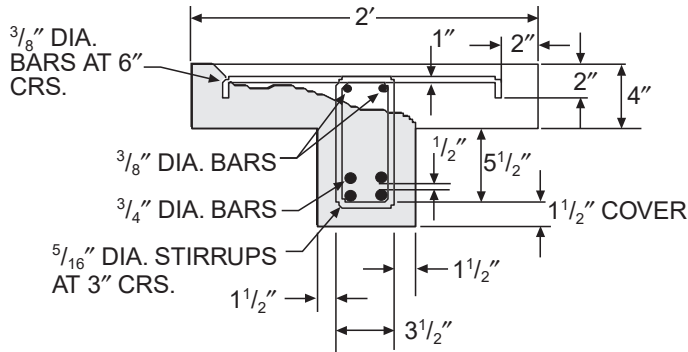

6.

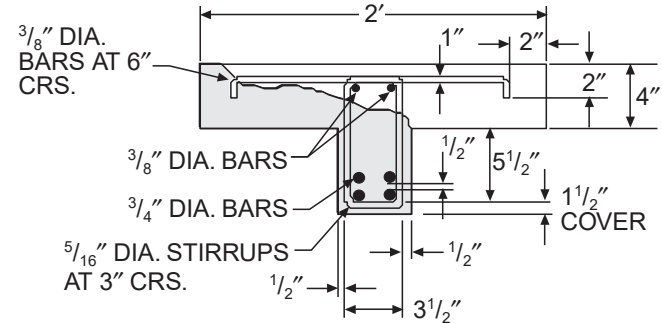

7.

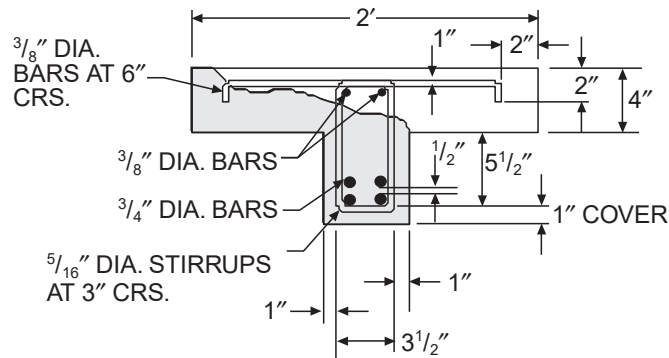

8.

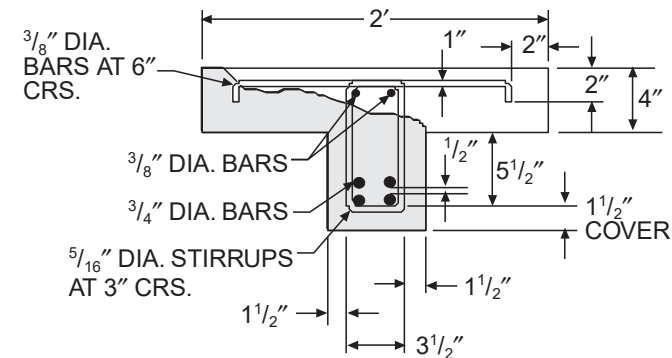

9.

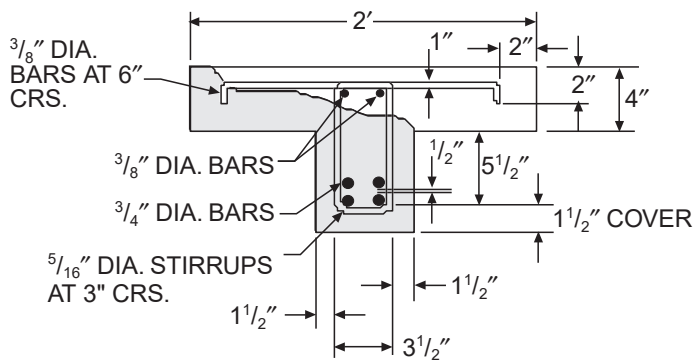

10.

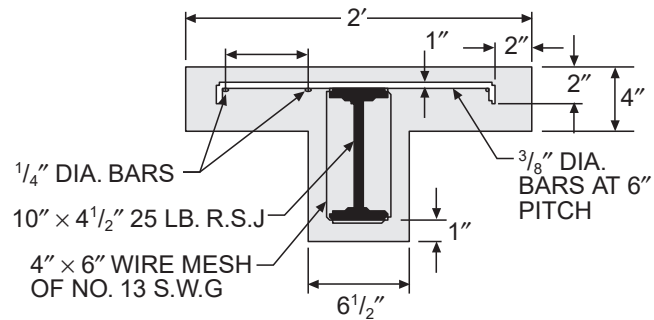

(continued)

**TABLE 4.1.1—continued
REINFORCED CONCRETE BEAMS
DEPTH 10" TO LESS THAN 12"**

11.

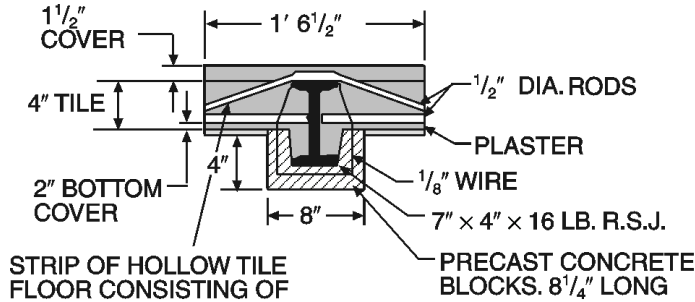

STRIP OF HOLLOW TILE FLOOR CONSISTING OF REINFORCED CONCRETE RIBS, 3/4" WIDE WITH 12" x 6" x 4" HOLLOW CLAY TILES.

SPAN AND END CONDITIONS:-10'-3" (CLEAR). SIMPLY SUPPORTED.

12.

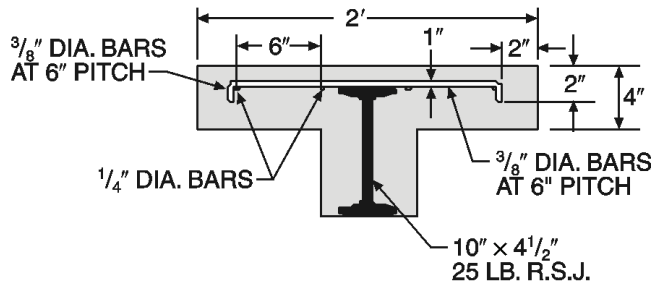

13.

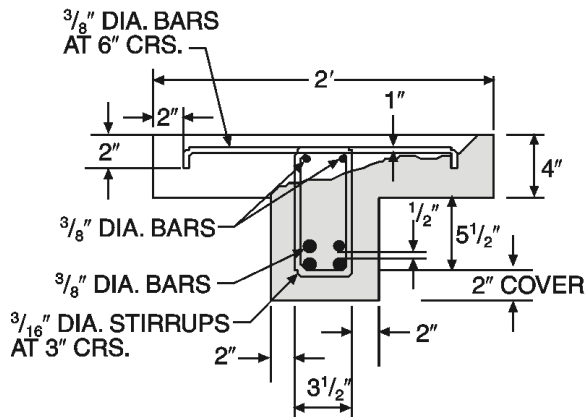

14. The different performances achieved by B-11-RC-1, B-11-RC-4 and B-11-RC-5 are attributable to differences in concrete aggregate compositions reported in the source document but unreported in this table. This demonstrates the significance of material composition in addition to other details.

**TABLE 4.1.2
REINFORCED CONCRETE BEAMS
DEPTH 12" TO LESS THAN 14"**

ITEM CODE	DEPTH	CONSTRUCTION DETAILS	PERFORMANCE		REFERENCE NUMBER			NOTES	REC. HOURS
			LOAD	TIME	PRE-BMS-92	BMS-92	POST-BMS-92		
B-12-RC-1	12"	12" × 8" section; 4160 psi aggregate concrete; Reinforcement: 4- ⁷ / ₈ " rebars at corners; 1" below each surface; ¹ / ₄ " stirrups 10" o.c.	5.5 tons	2 hrs.			7	1	2
B-12-RC-2	12"	Concrete flange: 4" deep × 2' wide (3045 psi) concrete at 35 days; Concrete beam: 8" deep; "I" beam reinforcement: 10" × 4 ¹ / ₂ " × 25 lbs. R.S.J.; 1" cover on flanges; Flange reinforcement: ³ / ₈ " diameter bars at 6" pitch parallel to "T"; ¹ / ₄ " diameter bars perpendicular to "T"; Beam reinforcement: 4" × 6" wire mesh No. 13 SWG; Span: 10' 3" simply supported.	10 tons	4 hrs.			7	2, 3, 5	4
B-13-RC-3	13"	Concrete flange: 4" deep × 2' wide (3825 psi) concrete at 46 days; Concrete beam: 9" deep × 8 ¹ / ₂ " wide; (scaled from drawing); "I" beam reinforcement: 10" × 4 ¹ / ₂ " × 25 lbs. R.S.J.; 3" cover on bottom flange; 1" cover on top flange; Flange reinforcement: ³ / ₈ " diameter bars at 6" pitch parallel to "T"; ¹ / ₄ " diameter bars perpendicular to "T"; Beam reinforcement: 4" × 6" wire mesh No. 13 SWG; Span: 11' restrained.	10 tons	6 hrs.			7	2, 3, 6, 8, 9	4
B-12-RC-4	12"	Concrete flange: 4" deep × 2' wide (3720 psi) concrete at 42 days; Concrete beam: 8" deep × 8 ¹ / ₂ " wide; (scaled from drawing); "I" beam reinforcement: 10" × 4 ¹ / ₂ " × 25 lbs. R.S.J.; 2" cover bottom flange; 1" cover top flange; Flange reinforcement: ³ / ₈ " diameter bars at 6" pitch parallel to "T"; ¹ / ₄ " diameter bars perpendicular to "T"; Beam reinforcement: 4" × 6" wire mesh No. 13 SWG; Span: 11' restrained.	10 tons	6 hrs.			7	1, 3, 4, 7, 8, 9	4

For SI: 1 inch = 25.4 mm, 1 foot = 305 mm, 1 pound = 0.004448 kN, 1 pound per square inch = 0.00689 MPa, 1 ton = 8.896 kN.

Notes:

1. Qualified for 2 hour use. (Grade "C," British) Test included hose stream and reload at 48 hours.
2. Load concentrated at mid span.
3. British test.
4. British test—qualified for 6 hour use (Grade "A").

(continued)

**TABLE 4.1.2—continued
REINFORCED CONCRETE BEAMS
DEPTH 12" TO LESS THAN 14"**

5.

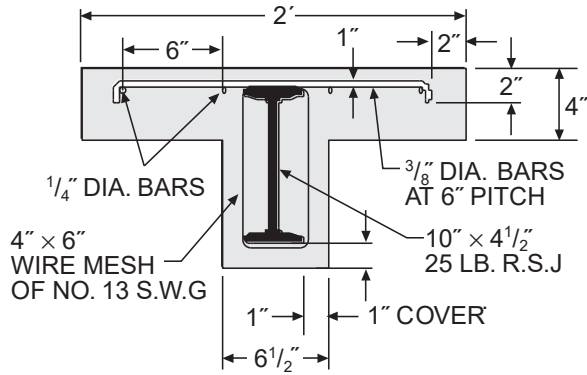

6.

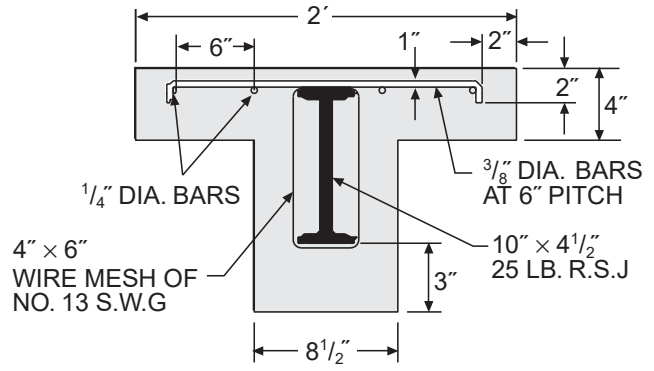

7.

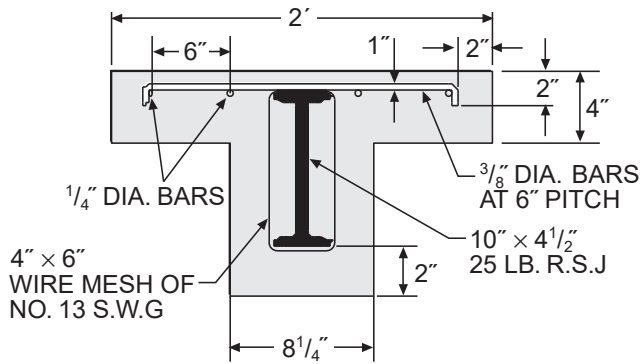

8. See Table 4.1.3, Note 5.

9. Hourly rating based upon B-12-RC-2 above.

**TABLE 4.1.3
REINFORCED CONCRETE BEAMS
DEPTH 14" TO LESS THAN 16"**

ITEM CODE	DEPTH	CONSTRUCTION DETAILS	PERFORMANCE		REFERENCE NUMBER			NOTES	REC. HOURS
			LOAD	TIME	PRE-BMS-92	BMS-92	POST-BMS-92		
B-15-RC-1	15"	Concrete flange: 4" deep × 2' wide (3290 psi) concrete; Concrete beam: 10" deep × 8½" wide; "I" beam reinforcement: 10" × 4½" × 25 lbs. R.S.J.; 4" cover on bottom flange; 1" cover on top flange; Flange reinforcement: 3/8" diameter bars at 6" pitch parallel to "T"; 1/4" diameter bars perpendicular to "T"; Beam reinforcement: 4" × 6" wire mesh No. 13 SWG; Span: 11' restrained.	10 tons	6 hrs.			7	1, 2, 3 5, 6	4
B-15-RC-2	15"	Concrete flange: 4" deep × 2' wide (4820 psi) concrete; Concrete beam: 10" deep × 8½" wide; "I" beam reinforcement: 10" × 4½" × 25 lbs. R.S.J.; 1" cover over wire mesh on bottom flange; 1" cover on top flange; Flange reinforcement: 3/8" diameter bars at 6" pitch parallel to "T"; 1/4" diameter bars perpendicular to "T"; Beam reinforcement: 4" × 6" wire mesh No. 13 SWG; Span: 11' restrained.	10 tons	6 hrs.			7	1, 2, 4, 5, 6	4

For SI: 1 inch = 25.4 mm, 1 foot = 305 mm, 1 pound = 0.004448 kN, 1 pound per square inch = 0.00689 MPa, 1 ton = 8.896 kN.

Notes:

1. Load concentrated at mid span.
2. Achieved 6 hour fire rating (Grade "A," British).
- 3.

4.

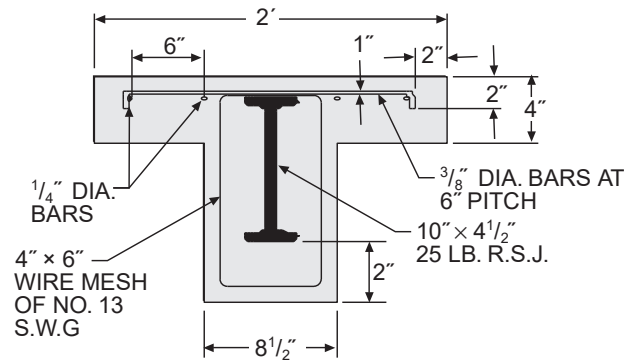
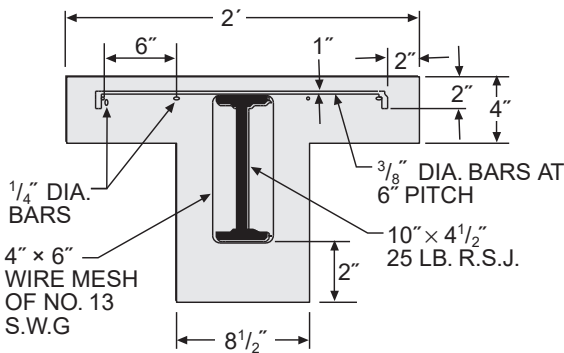

5. Section 43.147 of the 1979 edition of the *Uniform Building Code Standards* provides:

"A restrained condition in fire tests, as used in this standard, is one in which expansion at the supports of a load-carrying element resulting from the effects of the fire is resisted by forces external to the element. An unrestrained condition is one in which the load-carrying element is free to expand and rotate at its support."

"Restraint in buildings is defined as follows: Floor and roof assemblies and individual beams in buildings shall be considered restrained when the surrounding or supporting structure is capable of resisting the thermal expansion throughout the range of anticipated elevated temperatures. Construction not complying . . . is assumed to be free to rotate and expand and shall be considered as unrestrained."

"Restraint may be provided by the lateral stiffness of supports for floor and roof assemblies and intermediate beams forming part of the assembly. In order to develop restraint, connections must adequately transfer thermal thrusts to such supports. The rigidity of adjoining panels or structures shall be considered in assessing the capability of a structure to resist therm expansion."

Because it is difficult to determine whether an existing building's structural system is capable of providing the required restraint, the lower hourly ratings of a similar but unrestrained assembly have been recommended.

6. Hourly rating based upon Table 4.2.1, Item B-12-RC-2.

RESOURCE A

**TABLE 4.2.1
REINFORCED CONCRETE BEAMS—UNPROTECTED DEPTH
10" TO LESS THAN 12"**

ITEM CODE	DEPTH	CONSTRUCTION DETAILS	PERFORMANCE		REFERENCE NUMBER			NOTES	REC. HOURS
			LOAD	TIME	PRE- BMS-92	BMS-92	POST-BMS-92		
B-SU-1	10"	10" × 4½" × 25 lbs. "I" beam.	10 tons	39 min.			7	1	1/3

For SI: 1 inch = 25.4 mm, 1 pound = 0.004448 kN, 1 ton = 8.896 kN.

Notes:

1. Concentrated at mid span.

**TABLE 4.2.2
STEEL BEAMS—CONCRETE PROTECTION DEPTH
10" TO LESS THAN 12"**

ITEM CODE	DEPTH	CONSTRUCTION DETAILS	PERFORMANCE		REFERENCE NUMBER			NOTES	REC. HOURS
			LOAD	TIME	PRE- BMS-92	BMS-92	POST- BMS-92		
B-SC-1	10"	10" × 8" rectangle; aggregate concrete (4170 psi) with 1" top cover and 2" bottom cover; No. 13 SWG iron wire loosely wrapped at approximately 6" pitch about 7" × 4" × 16 lbs. "I" beam.	3.9 tons	3 hrs. 46 min.			7	1, 2, 3	3¾
B-SC-1	10"	10" × 8" rectangle; aggregate concrete (3630 psi) with 1" top cover and 2" bottom cover; No. 13 SWG iron wire loosely wrapped at approximately 6" pitch about 7" × 4" × 16 lbs. "I" beam.	5.5 tons	5 hrs. 26 min.			7	1, 4, 5, 6, 7	3¾

For SI: 1 inch = 25.4 mm, 1 pound = 0.004448 kN, 1 pound per square inch = 0.00689 MPa, 1 ton = 8.896 kN.

Notes:

1. Load concentrated at mid span.
2. Specimen 10-foot 3-inch clear span simply supported.
3. Passed Grade "C" fire resistance (British) including hose stream and reload.
4. Specimen 11-foot clear span—restrained.
5. Passed Grade "B" fire resistance (British) including hose stream and reload.
6. See Table 4.1.3, Note 5.
7. Hourly rating based upon B-SC-1 above.

**SECTION V
DOORS**

**FIGURE 5.1
RESISTANCE OF DOORS TO FIRE EXPOSURE**

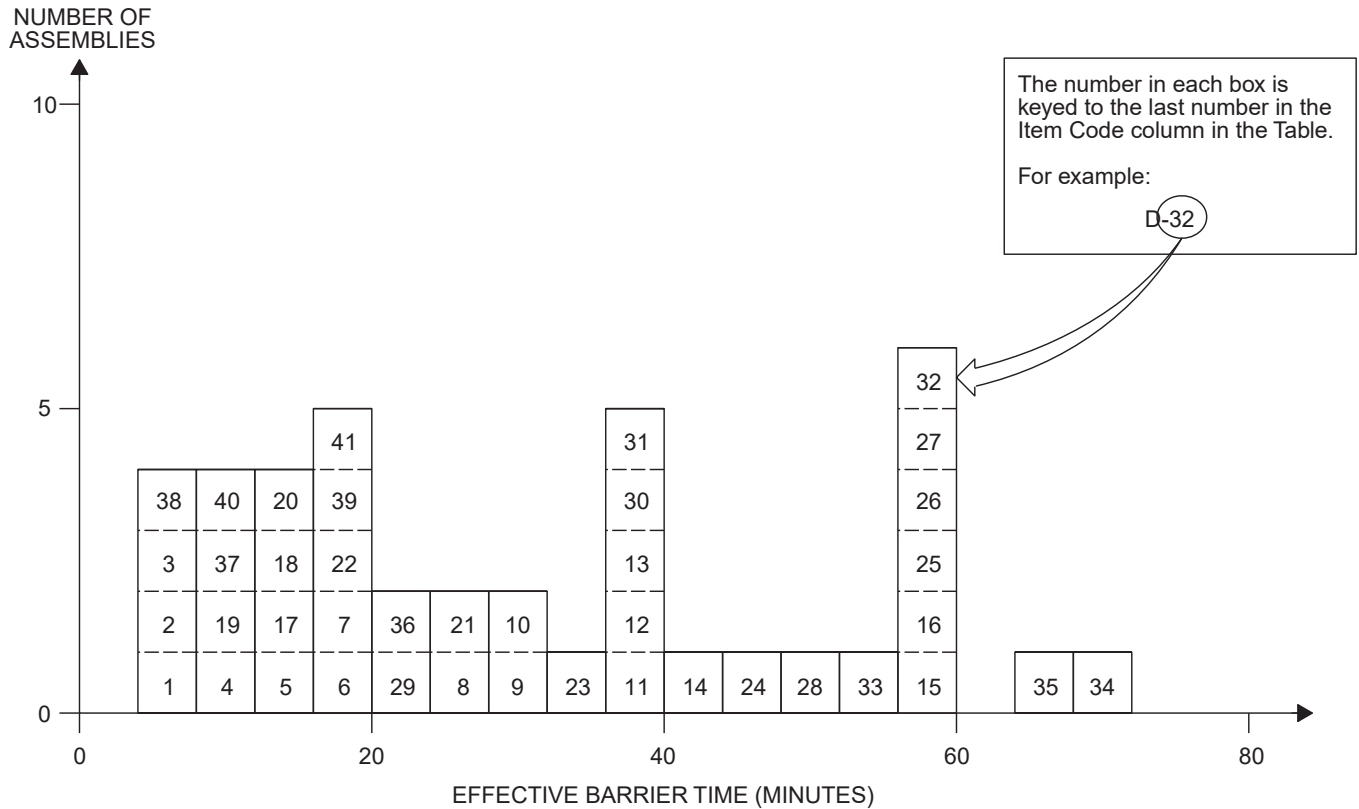

**TABLE 5.1
RESISTANCE OF DOORS TO FIRE EXPOSURE**

ITEM CODE	DOOR MINIMUM THICKNESS	CONSTRUCTION DETAILS	PERFORMANCE		REFERENCE NUMBER			NOTES	REC. (MIN.)
			EFFECTIVE BARRIER	EDGE FLAMING	PRE- BMS-92	BMS-92	POST- BMS-92		
D-1	3/8"	Panel door; pine perimeter (1 3/8"); painted (enamel).	5 min. 10 sec.	N/A			90	1, 2	5
D-2	3/8"	As above, with two coats U.L. listed intumescent coating.	5 min. 30 sec.	5 min.			90	1, 2, 7	5
D-3	3/8"	As D-1, with standard primer and flat interior paint.	5 min. 55 sec.	N/A			90	1, 3, 4	5
D-4	2 5/8"	As D-1, with panels covered each side with 1/2" plywood; edge grouted with sawdust filled plaster; door faced with 1/8" hard-board each side; paint see (5).	11 min. 15 sec.	3 min. 45 sec.			90	1, 2, 5, 7	10

(continued)

**TABLE 5.1—continued
RESISTANCE OF DOORS TO FIRE EXPOSURE**

ITEM CODE	DOOR MINIMUM THICKNESS	CONSTRUCTION DETAILS	PERFORMANCE		REFERENCE NUMBER			NOTES	REC. (MIN.)
			EFFECTIVE BARRIER	EDGE FLAMING	PRE- BMS-92	BMS-92	POST- BMS-92		
D-5	3/8"	As D-1, except surface protected with glass fiber reinforced intumescent fire retardant coating.	16 min.	N/A			90	1, 3, 4, 7	15
D-6	1 5/8"	Door detail: As D-4, except with 1/8" cement asbestos board facings with aluminum foil; door edges protected by sheet metal.	17 min.	10 min. 15 sec.			90	1, 3, 4	15
D-7	1 5/8"	Door detail with 1/8" hard-board cover each side as facings; glass fiber reinforced intumescent coating applied.	20 min.	N/A			90	1, 3, 4, 7	20
D-8	1 5/8"	Door detail same as D-4; paint was glass reinforced epoxy intumescent.	26 min.	24 min. 45 sec.			90	1, 3, 4, 6, 7	25
D-9	1 5/8"	Door detail same as D-4 with facings of 1/8" cement asbestos board.	29 min.	3 min. 15 sec.			90	1, 2	5
D-10	1 5/8"	As per D-9.	31 min. 30 sec.	7 min. 20 sec.			90	1, 3, 4	6
D-11	1 5/8"	As per D-7; painted with epoxy intumescent coating including glass fiber roving.	36 min. 25 sec.	N/A			90	1, 3, 4	35
D-12	1 5/8"	As per D-4 with intumescent fire retardant paint.	37 min. 30 sec.	24 min. 40 sec.			90	1, 3, 4	30
D-13	1 1/2" (nom.)	As per D-4, except with 24 ga. galvanized sheet metal facings.	39 min.	39 min.			90	1, 3, 4	39
D-14	1 5/8"	As per D-9.	41 min. 30 sec.	17 min. 20 sec.			90	1, 3, 4, 6	20
D-15	—	Class C steel fire door.	60 min.	58 min.			90	7, 8	60
D-16	—	Class B steel fire door.	60 min.	57 min.			90	7, 8	60
D-17	1 3/4"	Solid core flush door; core staves laminated to facings but not each other; Birch plywood facings 1/2" rebate in door frame for door; 3/32" clearance between door and wood frame.	15 min.	13 min.			37	11	13

(continued)

**TABLE 5.1—continued
RESISTANCE OF DOORS TO FIRE EXPOSURE**

ITEM CODE	DOOR MINIMUM THICKNESS	CONSTRUCTION DETAILS	PERFORMANCE		REFERENCE NUMBER			NOTES	REC. (MIN.)
			EFFECTIVE BARRIER	EDGE FLAMING	PRE- BMS-92	BMS-92	POST- BMS-92		
D-18	1 3/4"	As per D-17.	14 min.	13 min.			37	11	13
D-19	1 3/4"	Door same as D-17, except with 16 ga. steel; 3/32" door frame clearance.	12 min.	—			37	9, 11	10
D-20	1 3/4"	As per D-19.	16 min.	—			37	10, 11	10
D-21	1 3/4"	Doors as per D-17; intumescent paint applied to top and side edges.	26 min.	—			37	11	25
D-22	1 3/4"	Door as per D-17, except with 1/2" x 1/8" steel strip set into edges of door at top and side facing stops; matching strip on stop.	18 min.	6 min.			37	11	18
D-23	1 3/4"	Solid oak door.	36 min.	22 min.			15	13	25
D-24	1 7/8"	Solid oak door.	45 min.	35 min.			15	13	35
D-25	1 7/8"	Solid teak door.	58 min.	34 min.			15	13	35
D-26	1 7/8"	Solid (pitch) pine door.	57 min.	36 min.			15	13	35
D-27	1 7/8"	Solid deal (pine) door.	57 min.	30 min.			15	13	30
D-28	1 7/8"	Solid mahogany door.	49 min.	40 min.			15	13	45
D-29	1 7/8"	Solid poplar door.	24 min.	3 min.			15	13, 14	5
D-30	1 7/8"	Solid oak door.	40 min.	33 min.			15	13	35
D-31	1 7/8"	Solid walnut door.	40 min.	15 min.			15	13	20
D-32	2 5/8"	Solid Quebec pine.	60 min.	60 min.			15	13	60
D-33	2 5/8"	Solid pine door.	55 min.	39 min.			15	13	40
D-34	2 5/8"	Solid oak door.	69 min.	60 min.			15	13	60
D-35	2 5/8"	Solid teak door.	65 min.	17 min.			15	13	60
D-36	1 1/2"	Solid softwood door.	23 min.	8.5 min.			15	13	10
D-37	3/4"	Panel door.	8 min.	7.5 min.			15	13	5
D-38	5/16"	Panel door.	5 min.	5 min.			15	13	5
D-39	3/4"	Panel door, fire retardant treated.	17 1/2 min.	3 min.			15	13	8
D-40	3/4"	Panel door, fire retardant treated.	8 1/2 min.	8 1/2 min.			15	13	8
D-41	3/4"	Panel door, fire retardant treated.	16 3/4 min.	11 1/2 min.			15	13	8

For SI: 1 inch = 25.4 mm, 1 foot = 305 mm.

Notes:

- All door frames were of standard lumber construction.
- Wood door stop protected by asbestos millboard.
- Wood door stop protected by sheet metal.
- Door frame protected with sheet metal and weather strip.
- Surface painted with intumescent coating.
- Door edge sheet metal protected.
- Door edge intumescent paint protected.
- Formal steel frame and door stop.
- Door opened into furnace at 12 feet.
- Similar door opened into furnace at 12 feet.
- The doors reported in these tests represent the type contemporaries used as 20-minute solid-core wood doors. The test results demonstrate the necessity of having wall anchored metal frames, minimum cleaners possible between door, frame and stops. They also indicate the utility of long throw latches and the possible use of intumescent paints to seal doors to frames in event of a fire.
- Minimum working clearance and good latch closure are absolute necessities for effective containment for all such working door assemblies.
- Based on British tests.
- Failure at door-frame interface.

BIBLIOGRAPHY

1. Central Housing Committee on Research, Design, and Construction; Subcommittee on Fire Resistance Classifications, "Fire-Resistance Classifications of Building Constructions," *Building Materials and Structures*, Report BMS 92, National Bureau of Standards, Washington, Oct. 1942. (Available from NTIS No. COM-73-10974)
2. Foster, H. D., Pinkston, E. R., and Ingberg, S. H., "Fire Resistance of Structural Clay Tile Partitions," *Building Materials and Structures*, Report BMS 113, National Bureau of Standards, Washington, Oct. 1948.
3. Ryan, J. V., and Bender, E.W., "Fire Endurance of Open-Web Steel-Joist Floors with Concrete Slabs and Gypsum Ceilings," *Building Materials and Structures*, Report BMS 141, National Bureau of Standards, Washington, Aug. 1954.
4. Mitchell, N. D., "Fire Tests of Wood-Framed Walls and Partitions with Asbestos-Cement Facings," *Building Materials and Structures*, Report BMS 123, National Bureau of Standards, Washington, May 1951.
5. Robinson, H. E., Cosgrove, L. A., and Powell, F. J., "Thermal Resistance of Airspace and Fibrous Insulations Bounded by Reflective Surfaces," *Building Materials and Structures*, Report BMS 151, National Bureau of Standards, Washington, Nov. 1957.
6. Shoub, H., and Ingberg, S. H., "Fire Resistance of Steel Deck Floor Assemblies," *Building Science Series*, 11, National Bureau of Standards, Washington, Dec. 1967.
7. Davey, N., and Ashton, L. A., "Investigations on Building Fires, Part V: Fire Tests of Structural Elements," *National Building Studies*, Research Paper, No. 12, Dept. of Scientific and Industrial Research (Building Research Station), London, 1953.
8. National Board of Fire Underwriters, *Fire Resistance Ratings of Beam, Girder, and Truss Protections, Ceiling Constructions, Column Protections, Floor and Ceiling Constructions, Roof Constructions, Walls and Partitions*, New York, April 1959.
9. Mitchell, N.D., Bender, E.D., and Ryan, J.V., "Fire Resistance of Shutters for Moving-Stairway Openings," *Building Materials and Structures*, Report BMS 129, National Bureau of Standards, Washington, March 1952.
10. National Board of Fire Underwriters, *National Building Code; an Ordinance Providing for Fire Limits, and Regulations Governing the Construction, Alteration, Equipment, or Removal of Buildings or Structures*, New York, 1949.
11. Department of Scientific and Industrial Research and of the Fire Offices' Committee, Joint Committee of the Building Research Board, "Fire Gradings of Buildings, Part I: General Principles and Structural Precautions," *Post-War Building Studies*, No. 20, Ministry of Works, London, 1946.
12. Lawson, D. I., Webster, C. T., and Ashton, L. A., "Fire Endurance of Timber Beams and Floors," *National Building Studies*, Bulletin, No. 13, Dept. of Scientific and Industrial Research and Fire Offices' Committee (Joint Fire Research Organization), London, 1951.
13. Parker, T. W., Nurse, R. W., and Bessey, G. E., "Investigations on Building Fires. Part I: The Estimation of the Maximum Temperature Attained in Building Fires from Examination of the Debris, and Part II: The Visible Change in Concrete or Mortar Exposed to High Temperatures," *National Building Studies*, Technical Paper, No. 4, Dept. of Scientific and Industrial Research (Building Research Station), London, 1950.
14. Bevan, R. C., and Webster, C. T., "Investigations on Building Fires, Part III: Radiation from Building Fires," *National Building Studies*, Technical Paper, No. 5, Dept. of Scientific and Industrial Research (Building Research Station), London, 1950.
15. Webster, D. J., and Ashton, L. A., "Investigations on Building Fires, Part IV: Fire Resistance of Timber Doors," *National Building Studies*, Technical Paper, No. 6, Dept. of Scientific and Industrial Research (Building Research Station), London, 1951.
16. Kidder, F. E., *Architects' and Builders' Handbook: Data for Architects, Structural Engineers, Contractors, and Draughtsmen*, comp. by a Staff of Specialists and H. Parker, editor-in-chief, 18th ed., enl., J. Wiley, New York, 1936.
17. Parker, H., Gay, C. M., and MacGuire, J. W., *Materials and Methods of Architectural Construction*, 3rd ed., J. Wiley, New York, 1958.
18. Diets, A. G. H., *Dwelling House Construction*, The MIT Press, Cambridge, 1971.
19. Crosby, E. U., and Fiske, H. A., *Handbook of Fire Protection*, 5th ed., The Insurance Field Company, Louisville, Ky., 1914.
20. Crosby, E. U., Fiske, H. A., and Forster, H.W., *Handbook of Fire Protection*, 8th ed., R. S. Moulton, general editor, National Fire Protection Association, Boston, 1936.
21. Kidder, F. E., *Building Construction and Superintendence*, rev. and enl., by T. Nolan, W. T. Comstock, New York, 1909-1913, 2 vols.
22. National Fire Protection Association, Committee on Fire-Resistive Construction, *The Baltimore Conflagration*, 2nd ed., Chicago, 1904.
23. Przetak, L., *Standard Details for Fire-Resistive Building Construction*, McGraw-Hill Book Co., New York, 1977.

INDEX

A

ACCESSIBILITY 107.2, 301.5, 305, 801.1,
901.2, 1101.2,
1508, Appendix B

ADDITIONS 101.2, 101.3, 104.2,
115.5, 202, 301.3, 303.1, 305.5,
501.1, 502, 606, Chapter 11,
1301.1, 1301.1.1, 1301.2, 1301.2.3,
1301.3, 1301.4.1, 1301.4.3, 1505.2

ADMINISTRATION Chapter 1

ALTERATIONS 101.2, 101.3, 101.4, 101.7,
104.2, 104.10.1, 105.1.1, 105.1.2,
105.2.2, 105.2.3, 106.2.3, 106.2.6,
108.2, 108.5, 110.2, 113.2, 115.5, 202,
301.1, 301.3, 303, 305.1, 305.3,
305.4, 305.6, 305.7, 305.8, 305.9,
501.1, 501.1.1, 501.2.2, 502.4, 503,
504.1, 505.4, 508.1, 510.1, 510.1.4, 510.3,
510.4.1, 510.6, 510.7, 510.8, 510.8.1,
510.8.4, 510.8.10, 510.9, 601.1, 602,
603, 604, Chapter 7, Chapter 8,
Chapter 9, 1001.2.1, 1007.3.1, 1012.8,
1012.8.1, 1101.3, 1201.1, 1201.2, 1201.4,
1203.1, 1204, 1301.1, 1301.1.1,
1301.2, 1301.2.4, 1301.3, 1301.4.1,
1301.4.3, 1501.3, 1504.1, 1505.2,
A102.1, A105.2, A205.2, A403.2

Level 1 104.2.1, 202, 602, 603.2,
604.2, Chapter 7, 801.2

Level 2 106.2.3, 202, 603, 505.2, Chapter 8

Level 3 106.2.3, 202, 604, Chapter 9

**ALTERNATIVE MATERIALS, DESIGN,
AND METHODS OF
CONSTRUCTION** 104.11

APPEALS 112, 116.6

**ARCHAIC MATERIALS AND
ASSEMBLIES** Resource A

**ARCHITECT (see REGISTERED DESIGN
PROFESSIONAL)**

AREA (see BUILDING)

AUTOMATIC SPRINKLER SYSTEM 501.2, 504.5,
802.2.1, 802.6,
803.1.1, 803.2, 803.3, 803.4, 805.3.1.2.1,
805.3.1.2.2, 805.3.2, 805.5.1, 805.6, 902.2,
904.1, 1011.5.1, 1011.5.1.1, 1011.6.3,
1011.7.3, 1203.8, 1204.4, 1204.9, 1301.5.1,
Table 1301.6.9, 1301.6.10.1, 1301.6.17,
Table 1301.6.17, 1301.6.17.1,
1301.6.19, Table 1301.6.19, 1507

B

BOARD OF APPEALS 104.8, 112

BUILDING

Area 503.5, 503.7, 503.8, 503.9, 503.10,
1011.5, Table 1011.5, 1011.5.1.1,
1011.5.2, 1102, 1204.2,
1301.2.3, 1301.6.2

Dangerous 104.6.3, 114.1, 117.1, 202,
302.2, 405.1, 1205.2

Height 202, 502.1, 804.2.2, 805.3.1.1,
1007.3.1, 1011.5, Table 1011.5,
1011.6.1, 1011.6.3 1102.1, 1301.2.3,
1301.6.1, Table 1307.1, A301.2

Historic 202, 305.1, 305.9, 401.1, 410.1, 410.9,
501.1, 507, 507.3, 507.4, 601.1,
607, 701.1, 1001.2.1, Chapter 12,
1301.1, B101.1, B101.2, B101.3,
B101.4, B101.4.2, B101.5

Relocatable 202, 1401.1

Relocated 110.1, 301.4, 503.12,
608, 806.4, 1206, Chapter 14

Relocation of 101.2, 101.3, 101.4, 104.2, 105.2.2,
301.1, 301.3

Underground 1002.2

Unsafe 104.6, 115, 116, 117.1, 202

C

CARBON MONOXIDE 502.7, 503.15, 804, 1105

CARPETING 105.2, 702.2

CEILING 702.1, 802.2.1, 802.4,
903.2.1, 1011.3,
1011.4.1, 1203.5, 1203.7, 1204.10,
1301.6.3.2, A105.3, A113.1

**CERTIFICATE OF
OCCUPANCY** 110, 506.2, 1001.2, 1001.3

CHANGE OF OCCUPANCY 101.2, 101.3, 101.4,
104.2, 104.2.2, 106.2.6,
110.1, 115.5, 202, 301.3, 305.1, 305.4, 305.4.2,
501.1, 506, 506.1, 506.1.1, 506.4, 506.6,
605, Chapter 10, 1201.1, 1201.2, 1201.4,
1204, 1301.1, 1301.4.1,
1301.4.3, 1301.6.17, 1401.2, B101.2,
B101.3, B101.4, C101.1, C201.1,

CODE OFFICIAL Chapter 1, 202,
301.3, 302.2, 303.2, 405.2.3.1,
501.2, 506.1.1, 507.4, 802.6,
803.2.4, 805.2, 1001.2, 1011.4.1,
1106.1.1, 1201.2, 1201.3, 1201.5,

BENEFITS THAT WORK FOR YOU

No matter where you are in your building career, put the benefits of ICC Membership to work for you!

Membership in ICC connects you to exclusive I-Codes resources, continuing education opportunities and *Members-Only* benefits that include:

- Free code opinions from I-Codes experts
- Free I-Code book(s) or download to new Members*
- Discounts on I-Code resources, training and certification renewal
- Posting resumes and job search openings through the ICC Career Center
- Mentoring programs and valuable networking opportunities at ICC events
- Free benefits — Corporate and Governmental Members: Your staff can receive free ICC benefits too*
- *Savings of up to 25% on code books and training materials and more*

Put the benefits of ICC Membership to work for you and your career. Visit www.iccsafe.org/mem3 to join now or to renew your Membership. Or call 1-888-ICC-SAFE (422-7233), ext. 33804 to learn more today!



* Some restrictions apply. Speak with an ICC Member Services Representative for details.

16-12897

Specify and Approve with

CONFIDENCE



When facing new or unfamiliar materials, how do you know if they comply with building codes and standards?

ICC-ES® **Evaluation Reports** are the most widely accepted and trusted technical reports for code compliance.

ICC-ES **Building Product Listings** and **PMG Listings** show product compliance with applicable standard(s) referenced in the building and plumbing codes as well as other applicable codes.

ICC-ES provides a one-stop shop for the evaluation, listing and now testing of innovative building products through our newly formed cooperation with Innovation Research Labs, a highly respected ISO 17025 accredited testing lab with over 50 years of experience.

ICC-ES is a subsidiary of ICC®, the publisher of the codes used throughout the U.S. and many global markets, so you can be confident in their code expertise.

www.icc-es.org | 800-423-6587 x3877



Look for the ICC-ES Marks of Conformity





ICC Plan Review Services... For the most detailed and precise Plan Reviews in the industry

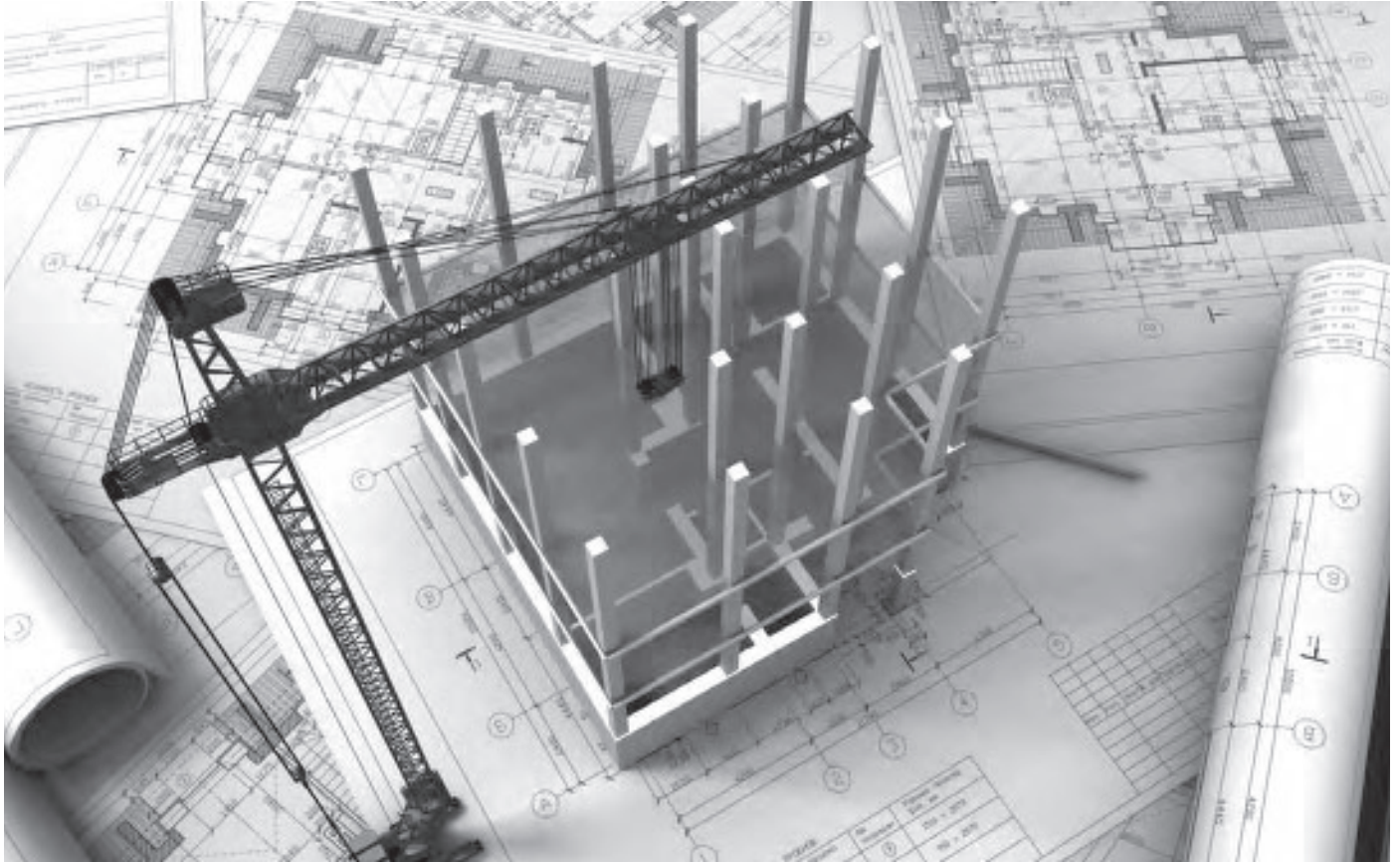

Ever wonder why code officials, architects and other building professionals value and accept ICC plan reviews?

- ***Experience*** – Our I-Code experts have expertise in **ALL** the International Codes® (I-Codes®)
- ***Detailed Report*** – identifies code deficiencies found
- ***Complimentary re-review of reissued plans****

Plus, ICC Plan Review Services has over 200 years of combined experience with applications of the codes, 6 registered design professionals on staff and 120 International Code Council Certifications, so you can be assured that ICC will deliver the most detailed and precise plan reviews in the industry.

**Applies to "Complete Plan Review Services". Contact ICC Plan Review staff for details.*

To get your plan review started now or to learn about disciplines reviewed, plan review options and more, visit www.iccsafe.org/plr4 or call **888-422-7233, x5577**.



**INTERNATIONAL
CODE
COUNCIL**

People Helping People Build a Safer World®

Valuable Guides to Changes in the 2018 I-Codes®

NEW!

FULL COLOR! HUNDREDS OF PHOTOS AND ILLUSTRATIONS!

SIGNIFICANT CHANGES TO THE 2018 INTERNATIONAL CODES®

Practical resources that offer a comprehensive analysis of the critical changes made between the 2015 and 2018 editions of the codes. Authored by ICC code experts, these useful tools are “must-have” guides to the many important changes in the 2018 International Codes.

Key changes are identified then followed by in-depth, expert discussion of how the change affects real world application. A full-color photo, table or illustration is included for each change to further clarify application.



SIGNIFICANT CHANGES TO THE IBC, 2018 EDITION

#7024S18

SIGNIFICANT CHANGES TO THE IRC, 2018 EDITION

#7101S18

SIGNIFICANT CHANGES TO THE IFC, 2018 EDITION

#7404S18

SIGNIFICANT CHANGES TO THE IPC/IMC/IFGC, 2018 EDITION

#7202S18

ORDER YOUR HELPFUL GUIDES TODAY!

1-800-786-4452 | www.iccsafe.org/books

HIRE ICC TO TEACH

Want your group to learn the Significant Changes to the I-Codes from an ICC expert instructor?
Schedule a seminar today!

email: ICCTraining@iccsafe.org | phone: **1-888-422-7233 ext. 33818**

17-14098

2 0 1 8

INTERNATIONAL CODES

IECC[®]

A Member of the International Code Family

INTERNATIONAL
ENERGY CONSERVATION CODE[®]



2 0 1 8

INTERNATIONAL CODES®

2018 I-CODE BONUS OFFER

Get a **free 45-day online subscription** to ICC's *premiumACCESS*™ 2018 I-Codes Complete Collection. Test drive many powerful, time-saving tools available to you from *premiumACCESS*. To activate your bonus, visit www.iccsafe.org/codebonus.

IECC®

A Member of the International Code Family®

INTERNATIONAL ENERGY CONSERVATION CODE®



2018 International Energy Conservation Code®

First Printing: August 2017

ISBN: 978-1-60983-749-5 (soft-cover edition)

COPYRIGHT © 2017
by
INTERNATIONAL CODE COUNCIL, INC.

Date of First Publication: August 31, 2017

ALL RIGHTS RESERVED. This 2018 *International Energy Conservation Code*® is a copyrighted work owned by the International Code Council, Inc. Without advance written permission from the copyright owner, no part of this book may be reproduced, distributed or transmitted in any form or by any means, including, without limitation, electronic, optical or mechanical means (by way of example, and not limitation, photocopying or recording by or in an information storage retrieval system). For information on use rights and permissions, please contact: Publications, 4051 Flossmoor Road, Country Club Hills, IL 60478. Phone 1-888-ICC-SAFE (422-7233).

Trademarks: “International Code Council,” the “International Code Council” logo, “ICC,” the “ICC” logo, “International Energy Conservation Code,” “IECC” and other names and trademarks appearing in this book are trademarks of the International Code Council, Inc., and/or its licensors (as applicable), and may not be used without permission.

PRINTED IN THE U.S.A.

PREFACE

Introduction

The *International Energy Conservation Code*® (IECC®) establishes minimum requirements for energy-efficient buildings using prescriptive and performance-related provisions. It is founded on broad-based principles that make possible the use of new materials and new energy-efficient designs. This 2018 edition is fully compatible with all of the *International Codes*® (I-Codes®) published by the International Code Council® (ICC®), including the *International Building Code*®, *International Existing Building Code*®, *International Fire Code*®, *International Fuel Gas Code*®, *International Green Construction Code*®, *International Mechanical Code*®, *International Plumbing Code*®, *International Private Sewage Disposal Code*®, *International Property Maintenance Code*®, *International Residential Code*®, *International Swimming Pool and Spa Code*®, *International Wildland-Urban Interface Code*®, *International Zoning Code*® and *International Code Council Performance Code*®.

This code contains separate provisions for commercial buildings and for low-rise residential buildings (3 stories or less in height above grade). Each set of provisions, IECC—Commercial Provisions and IECC—Residential Provisions, is separately applied to buildings within its respective scope. Each set of provisions is to be treated separately. Each contains a Scope and Administration chapter, a Definitions chapter, a General Requirements chapter, a chapter containing energy efficiency requirements and existing building provisions applicable to buildings within its scope.

The I-Codes, including this *International Energy Conservation Code*, are used in a variety of ways in both the public and private sectors. Most industry professionals are familiar with the I-Codes as the basis of laws and regulations in communities across the U.S. and in other countries. However, the impact of the codes extends well beyond the regulatory arena, as they are used in a variety of nonregulatory settings, including:

- Voluntary compliance programs such as those promoting sustainability, energy efficiency and disaster resistance.
- The insurance industry, to estimate and manage risk, and as a tool in underwriting and rate decisions.
- Certification and credentialing of individuals involved in the fields of building design, construction and safety.
- Certification of building and construction-related products.
- U.S. federal agencies, to guide construction in an array of government-owned properties.
- Facilities management.
- “Best practices” benchmarks for designers and builders, including those who are engaged in projects in jurisdictions that do not have a formal regulatory system or a governmental enforcement mechanism.
- College, university and professional school textbooks and curricula.
- Reference works related to building design and construction.

In addition to the codes themselves, the code development process brings together building professionals on a regular basis. It provides an international forum for discussion and deliberation about building design, construction methods, safety, performance requirements, technological advances and innovative products.

Development

This 2018 edition presents the code as originally issued, with changes reflected in the 2000 through 2015 editions and further changes approved through the ICC Code Development Process through 2017. A new edition such as this is promulgated every 3 years.

EFFECTIVE USE OF THE INTERNATIONAL ENERGY CONSERVATION CODE

The *International Energy Conservation Code* (IECC) is a model code that regulates minimum energy conservation requirements for new buildings. The IECC addresses energy conservation requirements for all aspects of energy uses in both commercial and residential construction, including heating and ventilating, lighting, water heating, and power usage for appliances and building systems.

The IECC is a design document. For example, before one constructs a building, the designer must determine the minimum insulation *R*-values and fenestration *U*-factors for the building exterior envelope. Depending on whether the building is for residential use or for commercial use, the IECC sets forth minimum requirements for exterior envelope insulation, window and door *U*-factors and SHGC ratings, duct insulation, lighting and power efficiency, and water distribution insulation.

Arrangement and Format of the 2018 IECC

The IECC contains two separate sets of provisions—one for commercial buildings and one for residential buildings. Each set of provisions is applied separately to buildings within their scope. The IECC—Commercial Provisions apply to all buildings except for residential buildings three stories or less in height. The IECC—Residential Provisions apply to detached one- and two-family dwellings and multiple single-family dwellings as well as *Group R-2*, *R-3* and *R-4* buildings three stories or less in height. These scopes are based on the definitions of “Commercial building” and “Residential building,” respectively, in Chapter 2 of each set of provisions. Note that the IECC—Commercial Provisions therefore contain provisions for residential buildings four stories or greater in height. Each set of provisions is divided into five different parts:

Chapters	Subjects
1–2	Administration and definitions
3	Climate zones and general materials requirements
4	Energy efficiency requirements
5	Existing buildings
6	Referenced standards

The following is a chapter-by-chapter synopsis of the scope and intent of the provisions of the *International Energy Conservation Code* and applies to both the commercial and residential energy provisions:

Chapter 1 Scope and Administration. This chapter contains provisions for the application, enforcement and administration of subsequent requirements of the code. In addition to establishing the scope of the code, Chapter 1 identifies which buildings and structures come under its purview. Chapter 1 is largely concerned with maintaining “due process of law” in enforcing the energy conservation criteria contained in the body of this code. Only through careful observation of the administrative provisions can the code official reasonably expect to demonstrate that “equal protection under the law” has been provided.

TABLE OF CONTENTS

<i>IECC—COMMERCIAL PROVISIONS.</i>	<i>C-1</i>	<i>IECC—RESIDENTIAL PROVISIONS.</i>	<i>R-1</i>
CHAPTER 1 SCOPE AND ADMINISTRATION	C-3	CHAPTER 1 SCOPE AND ADMINISTRATION	R-3
CHAPTER 2 DEFINITIONS	C-7	CHAPTER 2 DEFINITIONS	R-7
CHAPTER 3 GENERAL REQUIREMENTS	C-13	CHAPTER 3 GENERAL REQUIREMENTS	R-11
CHAPTER 4 COMMERCIAL ENERGY EFFICIENCY	C-31	CHAPTER 4 RESIDENTIAL ENERGY EFFICIENCY	R-29
CHAPTER 5 EXISTING BUILDINGS	C-101	CHAPTER 5 EXISTING BUILDINGS	R-45
CHAPTER 6 REFERENCED STANDARDS	C-105	CHAPTER 6 REFERENCED STANDARDS	R-49
APPENDIX CA SOLAR-READY ZONE—COMMERCIAL	C-113	APPENDIX RA SOLAR-READY PROVISIONS—DETACHED ONE- AND TWO-FAMILY DWELLINGS AND TOWNHOUSES	R-53
INDEX	C-115	INDEX	R-55

IECC—COMMERCIAL PROVISIONS

TABLE OF CONTENTS

CHAPTER 1 SCOPE AND ADMINISTRATION	C-3	CHAPTER 4 COMMERCIAL ENERGY EFFICIENCY	C-31
PART 1—SCOPE AND APPLICATION.	C-3	Section	
Section		C401 General.	C-31
C101 Scope and General Requirements.	C-3	C402 Building Envelope Requirements	C-31
C102 Alternative Materials, Design and Methods of Construction and Equipment	C-3	C403 Building Mechanical Systems	C-41
PART 2—ADMINISTRATION AND ENFORCEMENT	C-3	C404 Service Water Heating (Mandatory)	C-70
C103 Construction Documents	C-3	C405 Electrical Power and Lighting Systems.	C-74
C104 Fees.	C-5	C406 Additional Efficiency Package Options.	C-85
C105 Inspections	C-5	C407 Total Building Performance.	C-89
C106 Validity.	C-5	C408 Maintenance Information and System Commissioning	C-95
C107 Referenced Standards.	C-6	CHAPTER 5 EXISTING BUILDINGS.	C-101
C108 Stop Work Order	C-6	Section	
C109 Board of Appeals	C-6	C501 General.	C-101
CHAPTER 2 DEFINITIONS	C-7	C502 Additions	C-101
Section		C503 Alterations	C-102
C201 General	C-7	C504 Repairs.	C-103
C202 General Definitions	C-7	C505 Change of Occupancy or Use	C-103
CHAPTER 3 GENERAL REQUIREMENTS.	C-13	CHAPTER 6 REFERENCED STANDARDS.	C-105
Section		APPENDIX CA SOLAR-READY ZONE—COMMERCIAL.	C-113
C301 Climate Zones.	C-13	Section	
C302 Design Conditions	C-28	CA101 Scope.	C-113
C303 Materials, Systems and Equipment	C-28	CA102 General Definition	C-113
		CA103 Solar-ready Zone.	C-113
		INDEX.	C-115

CHAPTER 1 [CE]

SCOPE AND ADMINISTRATION

User note:

About this chapter: Chapter 1 establishes the limits of applicability of the code and describes how the code is to be applied and enforced. Chapter 1 is in two parts: Part 1—Scope and Application and Part 2—Administration and Enforcement. Section 101 identifies what buildings, systems, appliances and equipment fall under its purview and references other I-Codes as applicable. Standards and codes are scoped to the extent referenced.

The code is intended to be adopted as a legally enforceable document and it cannot be effective without adequate provisions for its administration and enforcement. The provisions of Chapter 1 establish the authority and duties of the code official appointed by the authority having jurisdiction and also establish the rights and privileges of the design professional, contractor and property owner.

PART 1—SCOPE AND APPLICATION

SECTION C101 SCOPE AND GENERAL REQUIREMENTS

C101.1 Title. This code shall be known as the *Energy Conservation Code* of [NAME OF JURISDICTION], and shall be cited as such. It is referred to herein as “this code.”

C101.2 Scope. This code applies to *commercial buildings* and the buildings’ sites and associated systems and equipment.

C101.3 Intent. This code shall regulate the design and construction of buildings for the effective use and conservation of energy over the useful life of each building. This code is intended to provide flexibility to permit the use of innovative approaches and techniques to achieve this objective. This code is not intended to abridge safety, health or environmental requirements contained in other applicable codes or ordinances.

C101.4 Applicability. Where, in any specific case, different sections of this code specify different materials, methods of construction or other requirements, the most restrictive shall govern. Where there is a conflict between a general requirement and a specific requirement, the specific requirement shall govern.

C101.4.1 Mixed residential and commercial buildings. Where a building includes both *residential building* and *commercial building* portions, each portion shall be separately considered and meet the applicable provisions of IECC—Commercial Provisions or IECC—Residential Provisions.

C101.5 Compliance. *Residential buildings* shall meet the provisions of IECC—Residential Provisions. *Commercial buildings* shall meet the provisions of IECC—Commercial Provisions.

C101.5.1 Compliance materials. The *code official* shall be permitted to approve specific computer software, worksheets, compliance manuals and other similar materials that meet the intent of this code.

SECTION C102

ALTERNATIVE MATERIALS, DESIGN AND METHODS OF CONSTRUCTION AND EQUIPMENT

C102.1 General. The provisions of this code are not intended to prevent the installation of any material or to prohibit any design or method of construction not specifically prescribed by this code, provided that any such alternative has been *approved*. An alternative material, design or method of construction shall be *approved* where the code official finds that the proposed design is satisfactory and complies with the intent of the provisions of this code, and that the material, method or work offered is, for the purpose intended, not less than the equivalent of that prescribed in this code in quality, strength, effectiveness, *fire resistance*, durability and safety. Where the alternative material, design or method of construction is not *approved*, the code official shall respond in writing, stating the reasons why the alternative was not *approved*.

C102.1.1 Above code programs. The *code official* or other authority having jurisdiction shall be permitted to deem a national, state or local energy efficiency program to exceed the energy efficiency required by this code. Buildings *approved* in writing by such an energy efficiency program shall be considered to be in compliance with this code. The requirements identified as “mandatory” in Chapter 4 shall be met.

PART 2—ADMINISTRATION AND ENFORCEMENT

SECTION C103 CONSTRUCTION DOCUMENTS

C103.1 General. Construction documents and other supporting data shall be submitted in one or more sets with each application for a permit. The construction documents shall be prepared by a registered design professional where required by the statutes of the jurisdiction in which the project is to be constructed. Where special conditions exist, the *code official* is authorized to require necessary construction documents to be prepared by a registered design professional.

Exception: The *code official* is authorized to waive the requirements for construction documents or other supporting data if the *code official* determines they are not necessary to confirm compliance with this code.

SECTION C104 FEES

C104.1 Fees. A permit shall not be issued until the fees prescribed in Section C104.2 have been paid, nor shall an amendment to a permit be released until the additional fee, if any, has been paid.

C104.2 Schedule of permit fees. A fee for each permit shall be paid as required, in accordance with the schedule as established by the applicable governing authority.

C104.3 Work commencing before permit issuance. Any person who commences any work before obtaining the necessary permits shall be subject to an additional fee established by the *code official* that shall be in addition to the required permit fees.

C104.4 Related fees. The payment of the fee for the construction, *alteration*, removal or demolition of work done in connection to or concurrently with the work or activity authorized by a permit shall not relieve the applicant or holder of the permit from the payment of other fees that are prescribed by law.

C104.5 Refunds. The *code official* is authorized to establish a refund policy.

SECTION C105 INSPECTIONS

C105.1 General. Construction or work for which a permit is required shall be subject to inspection by the code official, his or her designated agent or an approved agency, and such construction or work shall remain visible and able to be accessed for inspection purposes until *approved*. Approval as a result of an inspection shall not be construed to be an approval of a violation of the provisions of this code or of other ordinances of the jurisdiction. Inspections presuming to give authority to violate or cancel the provisions of this code or of other ordinances of the jurisdiction shall not be valid. It shall be the duty of the permit applicant to cause the work to remain visible and able to be accessed for inspection purposes. Neither the code official nor the jurisdiction shall be liable for expense entailed in the removal or replacement of any material, product, system or building component required to allow inspection to validate compliance with this code.

C105.2 Required inspections. The *code official*, his or her designated agent or an approved agency, upon notification, shall make the inspections set forth in Sections C105.2.1 through C105.2.6.

C105.2.1 Footing and foundation insulation. Inspections shall verify the footing and foundation insulation *R*-value, location, thickness, depth of burial and protection of insulation as required by the code, *approved* plans and specifications.

C105.2.2 Thermal envelope. Inspections shall verify the correct type of insulation, *R*-values, location of insulation, fenestration, *U*-factor, SHGC and VT, and that air leakage controls are properly installed, as required by the code, *approved* plans and specifications.

C105.2.3 Plumbing system. Inspections shall verify the type of insulation, *R*-values, protection required, controls and heat traps as required by the code, *approved* plans and specifications.

C105.2.4 Mechanical system. Inspections shall verify the installed HVAC equipment for the correct type and size, controls, insulation, *R*-values, system and damper air leakage, minimum fan efficiency, energy recovery and economizer as required by the code, *approved* plans and specifications.

C105.2.5 Electrical system. Inspections shall verify lighting system controls, components, and meters as required by the code, *approved* plans and specifications.

C105.2.6 Final inspection. The final inspection shall include verification of the installation and proper operation of all required building controls, and documentation verifying activities associated with required *building commissioning* have been conducted in accordance with Section C408.

C105.3 Reinspection. A building shall be reinspected where determined necessary by the *code official*.

C105.4 Approved inspection agencies. The *code official* is authorized to accept reports of third-party inspection agencies not affiliated with the building design or construction, provided that such agencies are *approved* as to qualifications and reliability relevant to the building components and systems that they are inspecting.

C105.5 Inspection requests. It shall be the duty of the holder of the permit or their duly authorized agent to notify the *code official* when work is ready for inspection. It shall be the duty of the permit holder to provide access to and means for inspections of such work that are required by this code.

C105.6 Reinspection and testing. Where any work or installation does not pass an initial test or inspection, the necessary corrections shall be made to achieve compliance with this code. The work or installation shall then be resubmitted to the *code official* for inspection and testing.

C105.7 Approval. After the prescribed tests and inspections indicate that the work complies in all respects with this code, a notice of approval shall be issued by the *code official*.

C105.7.1 Revocation. The *code official* is authorized to suspend or revoke, in writing, a notice of approval issued under the provisions of this code wherever the certificate is issued in error, or on the basis of incorrect information supplied, or where it is determined that the *building* or structure, premise, or portion thereof is in violation of any ordinance or regulation or any of the provisions of this code.

SECTION C106 VALIDITY

C106.1 General. If a portion of this code is held to be illegal or void, such a decision shall not affect the validity of the remainder of this code.

SECTION C107 REFERENCED STANDARDS

C107.1 Referenced codes and standards. The codes and standards referenced in this code shall be those listed in Chapter 6, and such codes and standards shall be considered as part of the requirements of this code to the prescribed extent of each such reference and as further regulated in Sections C107.1.1 and C107.1.2.

C107.1.1 Conflicts. Where conflicts occur between provisions of this code and referenced codes and standards, the provisions of this code shall apply.

C107.1.2 Provisions in referenced codes and standards. Where the extent of the reference to a referenced code or standard includes subject matter that is within the scope of this code, the provisions of this code, as applicable, shall take precedence over the provisions in the referenced code or standard.

C107.2 Application of references. References to chapter or section numbers, or to provisions not specifically identified by number, shall be construed to refer to such chapter, section or provision of this code.

C107.3 Other laws. The provisions of this code shall not be deemed to nullify any provisions of local, state or federal law.

SECTION C108 STOP WORK ORDER

C108.1 Authority. Where the *code official* finds any work regulated by this code being performed in a manner either contrary to the provisions of this code or dangerous or unsafe, the *code official* is authorized to issue a stop work order.

C108.2 Issuance. The stop work order shall be in writing and shall be given to the owner of the property involved, the owner's authorized agent, or to the person doing the work. Upon issuance of a stop work order, the cited work shall immediately cease. The stop work order shall state the reason for the order and the conditions under which the cited work will be permitted to resume.

C108.3 Emergencies. Where an emergency exists, the *code official* shall not be required to give a written notice prior to stopping the work.

C108.4 Failure to comply. Any person who shall continue any work after having been served with a stop work order, except such work as that person is directed to perform to remove a violation or unsafe condition, shall be liable to a fine as set by the applicable governing authority.

SECTION C109 BOARD OF APPEALS

C109.1 General. In order to hear and decide appeals of orders, decisions or determinations made by the *code official* relative to the application and interpretation of this code, there shall be and is hereby created a board of appeals. The *code official* shall be an ex officio member of said board but shall not have a vote on any matter before the board. The board of appeals shall be appointed by the governing body

and shall hold office at its pleasure. The board shall adopt rules of procedure for conducting its business, and shall render all decisions and findings in writing to the appellant with a duplicate copy to the *code official*.

C109.2 Limitations on authority. An application for appeal shall be based on a claim that the true intent of this code or the rules legally adopted thereunder have been incorrectly interpreted, the provisions of this code do not fully apply or an equally good or better form of construction is proposed. The board shall not have authority to waive requirements of this code.

C109.3 Qualifications. The board of appeals shall consist of members who are qualified by experience and training and are not employees of the jurisdiction.

CHAPTER 2 [CE]

DEFINITIONS

User note:

About this chapter: Codes, by their very nature, are technical documents. Every word, term and punctuation mark can add to or change the meaning of a technical requirement. It is necessary to maintain a consensus on the specific meaning of each term contained in the code. Chapter 2 performs this function by stating clearly what specific terms mean for the purposes of the code.

SECTION C201 GENERAL

C201.1 Scope. Unless stated otherwise, the following words and terms in this code shall have the meanings indicated in this chapter.

C201.2 Interchangeability. Words used in the present tense include the future; words in the masculine gender include the feminine and neuter; the singular number includes the plural and the plural includes the singular.

C201.3 Terms defined in other codes. Terms that are not defined in this code but are defined in the *International Building Code*, *International Fire Code*, *International Fuel Gas Code*, *International Mechanical Code*, *International Plumbing Code* or the *International Residential Code* shall have the meanings ascribed to them in those codes.

C201.4 Terms not defined. Terms not defined by this chapter shall have ordinarily accepted meanings such as the context implies.

SECTION C202 GENERAL DEFINITIONS

ABOVE-GRADE WALL. See “Wall, above-grade.”

ACCESS (TO). That which enables a device, appliance or equipment to be reached by ready access or by a means that first requires the removal or movement of a panel, or similar obstruction.

ADDITION. An extension or increase in the *conditioned space* floor area, number of stories or height of a building or structure.

AIR BARRIER. One or more materials joined together in a continuous manner to restrict or prevent the passage of air through the building thermal envelope and its assemblies.

AIR CURTAIN. A device, installed at the building entrance, that generates and discharges a laminar air stream intended to prevent the infiltration of external, unconditioned air into the conditioned spaces, or the loss of interior, conditioned air to the outside.

ALTERATION. Any construction, retrofit or renovation to an existing structure other than repair or addition. Also, a change in a building, electrical, gas, mechanical or plumbing system that involves an extension, addition or change to the arrangement, type or purpose of the original installation.

APPROVED. Acceptable to the code official.

APPROVED AGENCY. An established and recognized agency that is regularly engaged in conducting tests or furnishing inspection services, or furnishing product certifica-

tion research reports, where such agency has been approved by the *code official*.

AUTOMATIC. Self-acting, operating by its own mechanism when actuated by some impersonal influence, as, for example, a change in current strength, pressure, temperature or mechanical configuration (see “Manual”).

BELOW-GRADE WALL. See “Wall, below-grade.”

BOILER, MODULATING. A boiler that is capable of more than a single firing rate in response to a varying temperature or heating load.

BOILER SYSTEM. One or more boilers, their piping and controls that work together to supply steam or hot water to heat output devices remote from the boiler.

BUBBLE POINT. The refrigerant liquid saturation temperature at a specified pressure.

BUILDING. Any structure used or intended for supporting or sheltering any use or occupancy, including any mechanical systems, service water heating systems and electric power and lighting systems located on the building site and supporting the building.

BUILDING COMMISSIONING. A process that verifies and documents that the selected building systems have been designed, installed, and function according to the owner’s project requirements and construction documents, and to minimum code requirements.

BUILDING ENTRANCE. Any door, set of doors, doorway, or other form of portal that is used to gain access to the building from the outside by the public.

BUILDING SITE. A contiguous area of land that is under the ownership or control of one entity.

BUILDING THERMAL ENVELOPE. The basement walls, exterior walls, floors, ceilings, roofs and any other building element assemblies that enclose conditioned space or provide a boundary between conditioned space and exempt or unconditioned space.

C-FACTOR (THERMAL CONDUCTANCE). The coefficient of heat transmission (surface to surface) through a building component or assembly, equal to the time rate of heat flow per unit area and the unit temperature difference between the warm side and cold side surfaces (Btu/h • ft² • °F) [W/(m² • K)].

CAPTIVE KEY OVERRIDE. A lighting control that will not release the key that activates the override when the lighting is on.

CAVITY INSULATION. Insulating material located between framing members.

CHAPTER 3 [CE]

GENERAL REQUIREMENTS

User note:

About this chapter: Chapter 3 addresses broadly applicable requirements that would not be at home in other chapters having more specific coverage of subject matter. This chapter establishes climate zone by U.S. counties and also contains product rating, marking and installation requirements for materials such as insulation, windows, doors and siding.

SECTION C301 CLIMATE ZONES

C301.1 General. *Climate zones* from Figure C301.1 or Table C301.1 shall be used for determining the applicable requirements from Chapter 4. Locations not indicated in Table C301.1 shall be assigned a *climate zone* in accordance with Section C301.3.

C301.2 Warm humid counties. In Table C301.1, warm humid counties are identified by an asterisk.

C301.3 International climate zones. The *climate zone* for any location outside the United States shall be determined by applying Table C301.3(1) and then Table C301.3(2).

C301.4 Tropical climate zone. The tropical *climate zone* shall be defined as:

1. Hawaii, Puerto Rico, Guam, American Samoa, U.S. Virgin Islands, Commonwealth of Northern Mariana Islands; and
2. Islands in the area between the Tropic of Cancer and the Tropic of Capricorn.

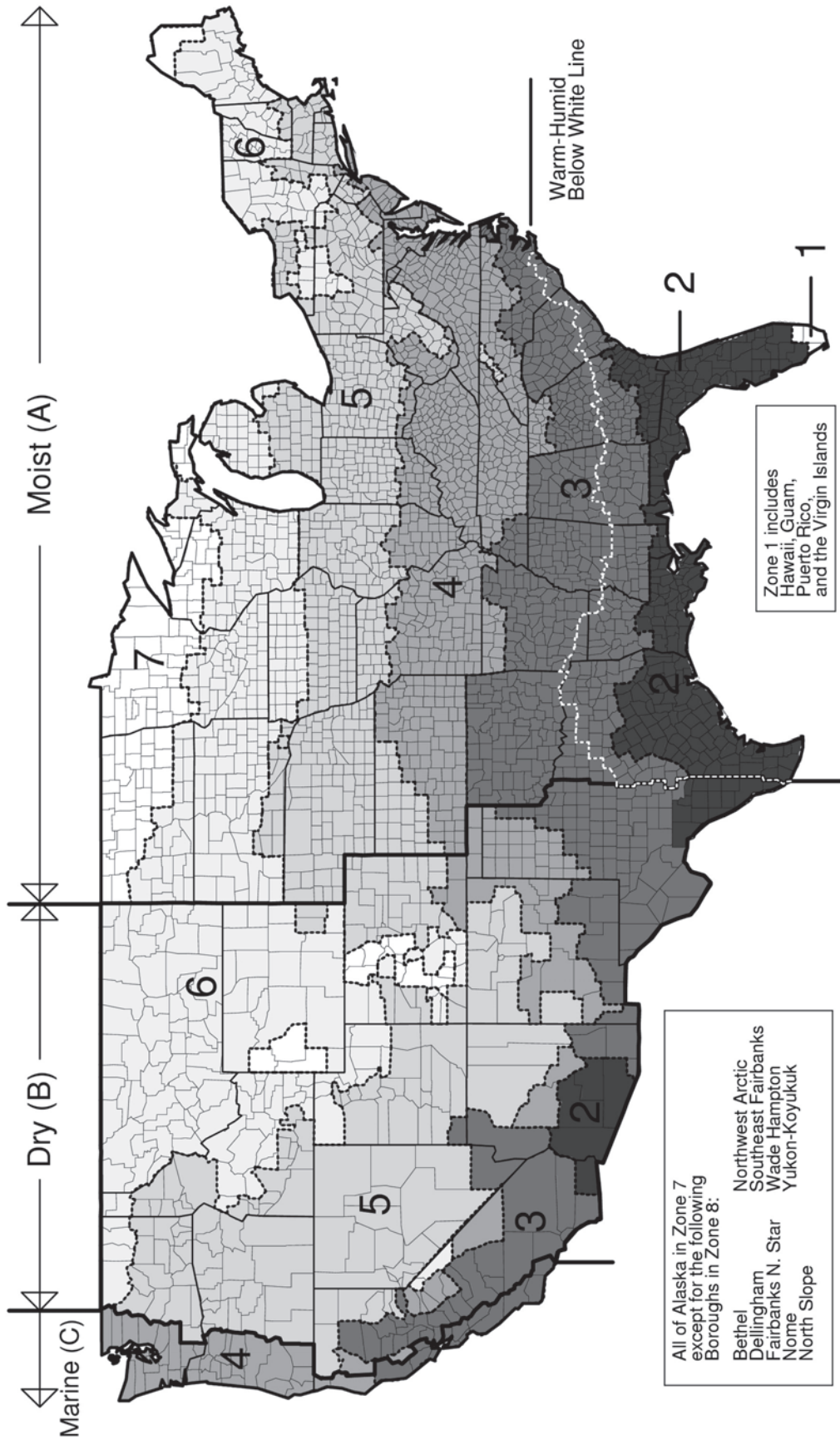

FIGURE C301.1
CLIMATE ZONES

TABLE C301.1
CLIMATE ZONES, MOISTURE REGIMES, AND WARM-HUMID
DESIGNATIONS BY STATE, COUNTY AND TERRITORY

Key: A – Moist, B – Dry, C – Marine. Absence of moisture designation indicates moisture regime is irrelevant.
Asterisk (*) indicates a warm-humid location.

US STATES

ALABAMA	3A Lee	7 Kodiak Island	3A Calhoun	3A Monroe
3A Autauga*	3A Limestone	7 Lake and Peninsula	4A Carroll	3A Montgomery
2A Baldwin*	3A Lowndes*	7 Matanuska-Susitna	3A Chicot	3A Nevada
3A Barbour*	3A Macon*	8 Nome	3A Clark	4A Newton
3A Bibb	3A Madison	8 North Slope	3A Clay	3A Ouachita
3A Blount	3A Marengo*	8 Northwest Arctic	3A Cleburne	3A Perry
3A Bullock*	3A Marion	7 Prince of Wales- Outer Ketchikan	3A Cleveland	3A Phillips
3A Butler*	3A Marshall	7 Sitka	3A Columbia*	3A Pike
3A Calhoun	2A Mobile*	7 Skagway-Hoonah- Angoon	3A Conway	3A Poinsett
3A Chambers	3A Monroe*	8 Southeast Fairbanks	3A Craighead	3A Polk
3A Cherokee	3A Montgomery*	7 Valdez-Cordova	3A Crawford	3A Pope
3A Chilton	3A Morgan	8 Wade Hampton	3A Crittenden	3A Prairie
3A Choctaw*	3A Perry*	7 Wrangell-Petersburg	3A Cross	3A Pulaski
3A Clarke*	3A Pickens	7 Yakutat	3A Dallas	3A Randolph
3A Clay	3A Pike*	8 Yukon-Koyukuk	3A Desha	3A Saline
3A Cleburne	3A Randolph		3A Drew	3A Scott
3A Coffee*	3A Russell*	ARIZONA	3A Faulkner	4A Searcy
3A Colbert	3A Shelby	5B Apache	3A Franklin	3A Sebastian
3A Conecuh*	3A St. Clair	3B Cochise	4A Fulton	3A Sevier*
3A Coosa	3A Sumter	5B Coconino	3A Garland	3A Sharp
3A Covington*	3A Talladega	4B Gila	3A Grant	3A St. Francis
3A Crenshaw*	3A Tallapoosa	3B Graham	3A Greene	4A Stone
3A Cullman	3A Tuscaloosa	3B Greenlee	3A Hempstead*	3A Union*
3A Dale*	3A Walker	2B La Paz	3A Hot Spring	3A Van Buren
3A Dallas*	3A Washington*	2B Maricopa	3A Howard	4A Washington
3A DeKalb	3A Wilcox*	3B Mohave	3A Independence	3A White
3A Elmore*	3A Winston	5B Navajo	4A Izard	3A Woodruff
3A Escambia*	ALASKA	2B Pima	3A Jackson	3A Yell
3A Etowah	7 Aleutians East	2B Pinal	3A Jefferson	CALIFORNIA
3A Fayette	7 Aleutians West	3B Santa Cruz	3A Johnson	3C Alameda
3A Franklin	7 Anchorage	4B Yavapai	3A Lafayette*	6B Alpine
3A Geneva*	8 Bethel	2B Yuma	3A Lawrence	4B Amador
3A Greene	7 Bristol Bay		3A Lee	3B Butte
3A Hale	7 Denali	ARKANSAS	3A Lincoln	4B Calaveras
3A Henry*	8 Dillingham	3A Arkansas	3A Little River*	3B Colusa
3A Houston*	8 Fairbanks North Star	3A Ashley	3A Logan	3B Contra Costa
3A Jackson	7 Haines	4A Baxter	3A Lonoke	4C Del Norte
3A Jefferson	7 Juneau	4A Benton	4A Madison	4B El Dorado
3A Lamar	7 Kenai Peninsula	4A Boone	4A Marion	3B Fresno
3A Lauderdale	7 Ketchikan Gateway	3A Bradley	3A Miller*	3B Glenn
3A Lawrence			3A Mississippi	

(continued)

GENERAL REQUIREMENTS

**TABLE C301.1—continued
CLIMATE ZONES, MOISTURE REGIMES, AND WARM-HUMID
DESIGNATIONS BY STATE, COUNTY AND TERRITORY**

4C Humboldt	3B Yuba	5B Montrose	2A Escambia*	2A Taylor*
2B Imperial	COLORADO	5B Morgan	2A Flagler*	2A Union*
4B Inyo	5B Adams	4B Otero	2A Franklin*	2A Volusia*
3B Kern	6B Alamosa	6B Ouray	2A Gadsden*	2A Wakulla*
3B Kings	5B Arapahoe	7 Park	2A Gilchrist*	2A Walton*
4B Lake	6B Archuleta	5B Phillips	2A Glades*	2A Washington*
5B Lassen	4B Baca	7 Pitkin	2A Gulf*	GEORGIA
3B Los Angeles	5B Bent	5B Prowers	2A Hamilton*	2A Appling*
3B Madera	5B Boulder	5B Pueblo	2A Hardee*	2A Atkinson*
3C Marin	5B Broomfield	6B Rio Blanco	2A Hendry*	2A Bacon*
4B Mariposa	6B Chaffee	7 Rio Grande	2A Hernando*	2A Baker*
3C Mendocino	5B Cheyenne	7 Routt	2A Highlands*	3A Baldwin
3B Merced	7 Clear Creek	6B Saguache	2A Hillsborough*	4A Banks
5B Modoc	6B Conejos	7 San Juan	2A Holmes*	3A Barrow
6B Mono	6B Costilla	6B San Miguel	2A Indian River*	3A Bartow
3C Monterey	5B Crowley	5B Sedgwick	2A Jackson*	3A Ben Hill*
3C Napa	6B Custer	7 Summit	2A Jefferson*	2A Berrien*
5B Nevada	5B Delta	5B Teller	2A Lafayette*	3A Bibb
3B Orange	5B Denver	5B Washington	2A Lake*	3A Bleckley*
3B Placer	6B Dolores	5B Weld	2A Lee*	2A Brantley*
5B Plumas	5B Douglas	5B Yuma	2A Leon*	2A Brooks*
3B Riverside	6B Eagle	CONNECTICUT	2A Levy*	2A Bryan*
3B Sacramento	5B Elbert	5A (all)	2A Liberty*	3A Bulloch*
3C San Benito	5B El Paso	DELAWARE	2A Madison*	3A Burke
3B San Bernardino	5B Fremont	4A (all)	2A Manatee*	3A Butts
3B San Diego	5B Garfield	DISTRICT OF	2A Marion*	3A Calhoun*
3C San Francisco	5B Gilpin	COLUMBIA	2A Martin*	2A Camden*
3B San Joaquin	7 Grand	4A (all)	1A Miami-Dade*	3A Candler*
3C San Luis Obispo	7 Gunnison	FLORIDA	2A Nassau*	3A Carroll
3C San Mateo	7 Hinsdale	2A Alachua*	2A Okaloosa*	4A Catoosa
3C Santa Barbara	5B Huerfano	2A Baker*	2A Okeechobee*	2A Charlton*
3C Santa Clara	7 Jackson	2A Bay*	2A Orange*	2A Chatham*
3C Santa Cruz	5B Jefferson	2A Bradford*	2A Osceola*	3A Chattahoochee*
3B Shasta	5B Kiowa	2A Brevard*	2A Palm Beach*	4A Chattooga
5B Sierra	5B Kit Carson	2A Broward*	2A Pasco*	3A Cherokee
5B Siskiyou	7 Lake	2A Calhoun*	2A Pinellas*	3A Clarke
3B Solano	5B La Plata	2A Charlotte*	2A Polk*	3A Clay*
3C Sonoma	5B Larimer	2A Citrus*	2A Putnam*	3A Clayton
3B Stanislaus	4B Las Animas	2A Clay*	2A Santa Rosa*	2A Clinch*
3B Sutter	5B Lincoln	2A Collier*	2A Sarasota*	3A Cobb
3B Tehama	5B Logan	2A Columbia*	2A Seminole*	3A Coffee*
4B Trinity	5B Mesa	2A DeSoto*	2A St. Johns*	2A Colquitt*
3B Tulare	7 Mineral	2A Dixie*	2A St. Lucie*	3A Columbia
4B Tuolumne	6B Moffat	2A Duval*	2A Sumter*	2A Cook*
3C Ventura	5B Montezuma		2A Suwannee*	3A Coweta
3B Yolo				

(continued)

TABLE C301.1—continued
CLIMATE ZONES, MOISTURE REGIMES, AND WARM-HUMID
DESIGNATIONS BY STATE, COUNTY AND TERRITORY

3A Crawford	2A Lanier*	3A Taylor*	5B Cassia	4A Crawford
3A Crisp*	3A Laurens*	3A Telfair*	6B Clark	5A Cumberland
4A Dade	3A Lee*	3A Terrell*	5B Clearwater	5A DeKalb
4A Dawson	2A Liberty*	2A Thomas*	6B Custer	5A De Witt
2A Decatur*	3A Lincoln	3A Tift*	5B Elmore	5A Douglas
3A DeKalb	2A Long*	2A Toombs*	6B Franklin	5A DuPage
3A Dodge*	2A Lowndes*	4A Towns	6B Fremont	5A Edgar
3A Dooly*	4A Lumpkin	3A Treutlen*	5B Gem	4A Edwards
3A Dougherty*	3A Macon*	3A Troup	5B Gooding	4A Effingham
3A Douglas	3A Madison	3A Turner*	5B Idaho	4A Fayette
3A Early*	3A Marion*	3A Twiggs*	6B Jefferson	5A Ford
2A Echols*	3A McDuffie	4A Union	5B Jerome	4A Franklin
2A Effingham*	2A McIntosh*	3A Upson	5B Kootenai	5A Fulton
3A Elbert	3A Meriwether	4A Walker	5B Latah	4A Gallatin
3A Emanuel*	2A Miller*	3A Walton	6B Lemhi	5A Greene
2A Evans*	2A Mitchell*	2A Ware*	5B Lewis	5A Grundy
4A Fannin	3A Monroe	3A Warren	5B Lincoln	4A Hamilton
3A Fayette	3A Montgomery*	3A Washington	6B Madison	5A Hancock
4A Floyd	3A Morgan	2A Wayne*	5B Minidoka	4A Hardin
3A Forsyth	4A Murray	3A Webster*	5B Nez Perce	5A Henderson
4A Franklin	3A Muscogee	3A Wheeler*	6B Oneida	5A Henry
3A Fulton	3A Newton	4A White	5B Owyhee	5A Iroquois
4A Gilmer	3A Oconee	4A Whitfield	5B Payette	4A Jackson
3A Glascock	3A Oglethorpe	3A Wilcox*	5B Power	4A Jasper
2A Glynn*	3A Paulding	3A Wilkes	5B Shoshone	4A Jefferson
4A Gordon	3A Peach*	3A Wilkinson	6B Teton	5A Jersey
2A Grady*	4A Pickens	3A Worth*	5B Twin Falls	5A Jo Daviess
3A Greene	2A Pierce*		6B Valley	4A Johnson
3A Gwinnett	3A Pike	HAWAII	5B Washington	5A Kane
4A Habersham	3A Polk	1A (all)*		5A Kankakee
4A Hall	3A Pulaski*	IDAHO	ILLINOIS	5A Kendall
3A Hancock	3A Putnam	5B Ada	5A Adams	5A Knox
3A Haralson	3A Quitman*	6B Adams	4A Alexander	5A Lake
3A Harris	4A Rabun	6B Bannock	4A Bond	5A La Salle
3A Hart	3A Randolph*	6B Bear Lake	5A Boone	4A Lawrence
3A Heard	3A Richmond	5B Benewah	5A Brown	5A Lee
3A Henry	3A Rockdale	6B Bingham	5A Bureau	5A Livingston
3A Houston*	3A Schley*	6B Blaine	5A Calhoun	5A Logan
3A Irwin*	3A Screven*	6B Boise	5A Carroll	5A Macon
3A Jackson	2A Seminole*	6B Bonner	5A Cass	4A Macoupin
3A Jasper	3A Spalding	6B Bonneville	5A Champaign	4A Madison
2A Jeff Davis*	4A Stephens	6B Boundary	4A Christian	4A Marion
3A Jefferson	3A Stewart*	6B Butte	5A Clark	5A Marshall
3A Jenkins*	3A Sumter*	6B Camas	4A Clay	5A Mason
3A Johnson*	3A Talbot	5B Canyon	4A Clinton	4A Massac
3A Jones	3A Taliaferro	6B Caribou	5A Coles	5A McDonough
3A Lamar	2A Tattnell*		5A Cook	5A McHenry

(continued)

GENERAL REQUIREMENTS

TABLE C301.1—continued
CLIMATE ZONES, MOISTURE REGIMES, AND WARM-HUMID
DESIGNATIONS BY STATE, COUNTY AND TERRITORY

5A McLean	5A Boone	5A Miami	5A Appanoose	5A Jasper
5A Menard	4A Brown	4A Monroe	5A Audubon	5A Jefferson
5A Mercer	5A Carroll	5A Montgomery	5A Benton	5A Johnson
4A Monroe	5A Cass	5A Morgan	6A Black Hawk	5A Jones
4A Montgomery	4A Clark	5A Newton	5A Boone	5A Keokuk
5A Morgan	5A Clay	5A Noble	6A Bremer	6A Kossuth
5A Moultrie	5A Clinton	4A Ohio	6A Buchanan	5A Lee
5A Ogle	4A Crawford	4A Orange	6A Buena Vista	5A Linn
5A Peoria	4A Daviess	5A Owen	6A Butler	5A Louisa
4A Perry	4A Dearborn	5A Parke	6A Calhoun	5A Lucas
5A Piatt	5A Decatur	4A Perry	5A Carroll	6A Lyon
5A Pike	5A De Kalb	4A Pike	5A Cass	5A Madison
4A Pope	5A Delaware	5A Porter	5A Cedar	5A Mahaska
4A Pulaski	4A Dubois	4A Posey	6A Cerro Gordo	5A Marion
5A Putnam	5A Elkhart	5A Pulaski	6A Cherokee	5A Marshall
4A Randolph	5A Fayette	5A Putnam	6A Chickasaw	5A Mills
4A Richland	4A Floyd	5A Randolph	5A Clarke	6A Mitchell
5A Rock Island	5A Fountain	4A Ripley	6A Clay	5A Monona
4A Saline	5A Franklin	5A Rush	6A Clayton	5A Monroe
5A Sangamon	5A Fulton	4A Scott	5A Clinton	5A Montgomery
5A Schuyler	4A Gibson	5A Shelby	5A Crawford	5A Muscatine
5A Scott	5A Grant	4A Spencer	5A Dallas	6A O'Brien
4A Shelby	4A Greene	5A Starke	5A Davis	6A Osceola
5A Stark	5A Hamilton	5A Steuben	5A Decatur	5A Page
4A St. Clair	5A Hancock	5A St. Joseph	6A Delaware	6A Palo Alto
5A Stephenson	4A Harrison	4A Sullivan	5A Des Moines	6A Plymouth
5A Tazewell	5A Hendricks	4A Switzerland	6A Dickinson	6A Pocahontas
4A Union	5A Henry	5A Tippecanoe	5A Dubuque	5A Polk
5A Vermilion	5A Howard	5A Tipton	6A Emmet	5A Pottawattamie
4A Wabash	5A Huntington	5A Union	6A Fayette	5A Poweshiek
5A Warren	4A Jackson	4A Vanderburgh	6A Floyd	5A Ringgold
4A Washington	5A Jasper	5A Vermillion	6A Franklin	6A Sac
4A Wayne	5A Jay	5A Vigo	5A Fremont	5A Scott
4A White	4A Jefferson	5A Wabash	5A Greene	5A Shelby
5A Whiteside	4A Jennings	5A Warren	6A Grundy	6A Sioux
5A Will	5A Johnson	4A Warrick	5A Guthrie	5A Story
4A Williamson	4A Knox	4A Washington	6A Hamilton	5A Tama
5A Winnebago	5A Kosciusko	5A Wayne	6A Hancock	5A Taylor
5A Woodford	5A LaGrange	5A Wells	6A Hardin	5A Union
INDIANA	5A Lake	5A White	5A Harrison	5A Van Buren
5A Adams	5A LaPorte	5A Whitley	5A Henry	5A Wapello
5A Allen	4A Lawrence	IOWA	6A Howard	5A Warren
5A Bartholomew	5A Madison	5A Adair	6A Humboldt	5A Washington
5A Benton	5A Marion	5A Adams	6A Ida	5A Wayne
5A Blackford	5A Marshall	6A Allamakee	5A Iowa	6A Webster
	4A Martin		5A Jackson	6A Winnebago

(continued)

TABLE C301.1—continued
CLIMATE ZONES, MOISTURE REGIMES, AND WARM-HUMID
DESIGNATIONS BY STATE, COUNTY AND TERRITORY

6A Winneshiek	4A Haskell	4A Sedgwick	2A Iberville*	6A Cumberland
5A Woodbury	4A Hodgeman	4A Seward	3A Jackson*	6A Franklin
6A Worth	4A Jackson	4A Shawnee	2A Jefferson*	6A Hancock
6A Wright	4A Jefferson	5A Sheridan	2A Jefferson Davis*	6A Kennebec
KANSAS	5A Jewell	5A Sherman	2A Lafayette*	6A Knox
4A Allen	4A Johnson	5A Smith	2A Lafourche*	6A Lincoln
4A Anderson	4A Kearny	4A Stafford	3A La Salle*	6A Oxford
4A Atchison	4A Kingman	4A Stanton	3A Lincoln*	6A Penobscot
4A Barber	4A Kiowa	4A Stevens	2A Livingston*	6A Piscataquis
4A Barton	4A Labette	4A Sumner	3A Madison*	6A Sagadahoc
4A Bourbon	5A Lane	5A Thomas	3A Morehouse	6A Somerset
4A Brown	4A Leavenworth	5A Trego	3A Natchitoches*	6A Waldo
4A Butler	4A Lincoln	4A Wabaunsee	2A Orleans*	6A Washington
4A Chase	4A Linn	5A Wallace	3A Ouachita*	6A York
4A Chautauqua	5A Logan	4A Washington	2A Plaquemines*	MARYLAND
4A Cherokee	4A Lyon	5A Wichita	2A Pointe Coupee*	4A Allegany
5A Cheyenne	4A Marion	4A Wilson	2A Rapides*	4A Anne Arundel
4A Clark	4A Marshall	4A Woodson	3A Red River*	4A Baltimore
4A Clay	4A McPherson	4A Wyandotte	3A Richland*	4A Baltimore (city)
5A Cloud	4A Meade	KENTUCKY	3A Sabine*	4A Calvert
4A Coffey	4A Miami	4A (all)	2A St. Bernard*	4A Caroline
4A Comanche	5A Mitchell	LOUISIANA	2A St. Charles*	4A Carroll
4A Cowley	4A Montgomery	2A Acadia*	2A St. Helena*	4A Cecil
4A Crawford	4A Morris	2A Allen*	2A St. James*	4A Charles
5A Decatur	4A Morton	2A Ascension*	2A St. John the Baptist*	4A Dorchester
4A Dickinson	4A Nemaha	2A Assumption*	2A St. Landry*	4A Frederick
4A Doniphan	4A Neosho	2A Avoyelles*	2A St. Martin*	5A Garrett
4A Douglas	5A Ness	2A Beauregard*	2A St. Mary*	4A Harford
4A Edwards	5A Norton	3A Bienville*	2A St. Tammany*	4A Howard
4A Elk	4A Osage	3A Bossier*	2A Tangipahoa*	4A Kent
5A Ellis	4A Osborne	3A Caddo*	3A Tensas*	4A Montgomery
4A Ellsworth	4A Ottawa	2A Calcasieu*	2A Terrebonne*	4A Prince George's
4A Finney	4A Pawnee	3A Caldwell*	3A Union*	4A Queen Anne's
4A Ford	5A Phillips	2A Cameron*	2A Vermilion*	4A Somerset
4A Franklin	4A Pottawatomie	3A Catahoula*	3A Vernon*	4A St. Mary's
4A Geary	4A Pratt	3A Claiborne*	2A Washington*	4A Talbot
5A Gove	5A Rawlins	3A Concordia*	3A Webster*	4A Washington
5A Graham	4A Reno	3A De Soto*	2A West Baton Rouge*	4A Wicomico
4A Grant	5A Republic	2A East Baton Rouge*	3A West Carroll	4A Worcester
4A Gray	4A Rice	3A East Carroll	2A West Feliciana*	MASSACHUSETTS
5A Greeley	4A Riley	2A East Feliciana*	3A Winn*	5A (all)
4A Greenwood	5A Rooks	2A Evangeline*	MAINE	MICHIGAN
5A Hamilton	4A Rush	3A Franklin*	6A Androscoggin	6A Alcona
4A Harper	4A Russell	3A Grant*	7 Aroostook	6A Alger
4A Harvey	4A Saline	2A Iberia*		
	5A Scott			

(continued)

GENERAL REQUIREMENTS

TABLE C301.1—continued
CLIMATE ZONES, MOISTURE REGIMES, AND WARM-HUMID
DESIGNATIONS BY STATE, COUNTY AND TERRITORY

5A Allegan	7 Mackinac	6A Carver	7 Otter Tail	3A Clarke
6A Alpena	5A Macomb	7 Cass	7 Pennington	3A Clay
6A Antrim	6A Manistee	6A Chippewa	7 Pine	3A Coahoma
6A Arenac	6A Marquette	6A Chisago	6A Pipestone	3A Copiah*
7 Baraga	6A Mason	7 Clay	7 Polk	3A Covington*
5A Barry	6A Mecosta	7 Clearwater	6A Pope	3A DeSoto
5A Bay	6A Menominee	7 Cook	6A Ramsey	3A Forrest*
6A Benzie	5A Midland	6A Cottonwood	7 Red Lake	3A Franklin*
5A Berrien	6A Missaukee	7 Crow Wing	6A Redwood	3A George*
5A Branch	5A Monroe	6A Dakota	6A Renville	3A Greene*
5A Calhoun	5A Montcalm	6A Dodge	6A Rice	3A Grenada
5A Cass	6A Montmorency	6A Douglas	6A Rock	2A Hancock*
6A Charlevoix	5A Muskegon	6A Faribault	7 Roseau	2A Harrison*
6A Cheboygan	6A Newaygo	6A Fillmore	6A Scott	3A Hinds*
7 Chippewa	5A Oakland	6A Freeborn	6A Sherburne	3A Holmes
6A Clare	6A Oceana	6A Goodhue	6A Sibley	3A Humphreys
5A Clinton	6A Ogemaw	7 Grant	6A Stearns	3A Issaquena
6A Crawford	7 Ontonagon	6A Hennepin	6A Steele	3A Itawamba
6A Delta	6A Osceola	6A Houston	6A Stevens	2A Jackson*
6A Dickinson	6A Oscoda	7 Hubbard	7 St. Louis	3A Jasper
5A Eaton	6A Otsego	6A Isanti	6A Swift	3A Jefferson*
6A Emmet	5A Ottawa	7 Itasca	6A Todd	3A Jefferson Davis*
5A Genesee	6A Presque Isle	6A Jackson	6A Traverse	3A Jones*
6A Gladwin	6A Roscommon	7 Kanabec	6A Wabasha	3A Kemper
7 Gogebic	5A Saginaw	6A Kandiyohi	7 Wadena	3A Lafayette
6A Grand Traverse	6A Sanilac	7 Kittson	6A Waseca	3A Lamar*
5A Gratiot	7 Schoolcraft	7 Koochiching	6A Washington	3A Lauderdale
5A Hillsdale	5A Shiawassee	6A Lac qui Parle	6A Watonwan	3A Lawrence*
7 Houghton	5A St. Clair	7 Lake	7 Wilkin	3A Leake
6A Huron	5A St. Joseph	7 Lake of the Woods	6A Winona	3A Lee
5A Ingham	5A Tuscola	6A Le Sueur	6A Wright	3A Leflore
5A Ionia	5A Van Buren	6A Lincoln	6A Yellow	3A Lincoln*
6A Iosco	5A Washtenaw	6A Lyon	Medicine	3A Lowndes
7 Iron	5A Wayne	7 Mahanomen	MISSISSIPPI	3A Madison
6A Isabella	6A Wexford	7 Marshall	3A Adams*	3A Marion*
5A Jackson	MINNESOTA	6A Martin	3A Alcorn	3A Marshall
5A Kalamazoo	7 Aitkin	6A McLeod	3A Amite*	3A Monroe
6A Kalkaska	6A Anoka	6A Meeker	3A Attala	3A Montgomery
5A Kent	7 Becker	7 Mille Lacs	3A Benton	3A Neshoba
7 Keweenaw	7 Beltrami	6A Morrison	3A Bolivar	3A Newton
6A Lake	6A Benton	6A Mower	3A Calhoun	3A Noxubee
5A Lapeer	6A Big Stone	6A Murray	3A Carroll	3A Oktibbeha
6A Leelanau	6A Blue Earth	6A Nicollet	3A Chickasaw	3A Panola
5A Lenawee	6A Brown	6A Nobles	3A Choctaw	2A Pearl River*
5A Livingston	7 Carlton	7 Norman	3A Claiborne*	3A Perry*
7 Luce		6A Olmsted		3A Pike*

(continued)

TABLE C301.1—continued
CLIMATE ZONES, MOISTURE REGIMES, AND WARM-HUMID
DESIGNATIONS BY STATE, COUNTY AND TERRITORY

3A Pontotoc	5A Chariton	4A Mississippi	4A Webster	4A Cumberland
3A Prentiss	4A Christian	4A Moniteau	5A Worth	4A Essex
3A Quitman	5A Clark	4A Monroe	4A Wright	4A Gloucester
3A Rankin*	4A Clay	4A Montgomery	MONTANA	4A Hudson
3A Scott	5A Clinton	4A Morgan	6B (all)	5A Hunterdon
3A Sharkey	4A Cole	4A New Madrid	NEBRASKA	5A Mercer
3A Simpson*	4A Cooper	4A Newton	5A (all)	4A Middlesex
3A Smith*	4A Crawford	5A Nodaway	NEVADA	4A Monmouth
2A Stone*	4A Dade	4A Oregon	5B Carson City (city)	5A Morris
3A Sunflower	4A Dallas	4A Osage	5B Churchill	4A Ocean
3A Tallahatchie	5A Daviess	4A Ozark	3B Clark	5A Passaic
3A Tate	5A DeKalb	4A Pemiscot	5B Douglas	4A Salem
3A Tippah	4A Dent	4A Perry	5B Elko	5A Somerset
3A Tishomingo	4A Douglas	4A Pettis	5B Esmeralda	5A Sussex
3A Tunica	4A Dunklin	4A Phelps	5B Eureka	4A Union
3A Union	4A Franklin	5A Pike	5B Humboldt	5A Warren
3A Walthall*	4A Gasconade	4A Platte	5B Lander	NEW MEXICO
3A Warren*	5A Gentry	4A Polk	5B Lincoln	4B Bernalillo
3A Washington	4A Greene	4A Pulaski	5B Lyon	5B Catron
3A Wayne*	5A Grundy	5A Putnam	5B Mineral	3B Chaves
3A Webster	5A Harrison	5A Ralls	5B Nye	4B Cibola
3A Wilkinson*	4A Henry	4A Randolph	5B Pershing	5B Colfax
3A Winston	4A Hickory	4A Ray	5B Storey	4B Curry
3A Yalobusha	5A Holt	4A Reynolds	5B Washoe	4B DeBaca
3A Yazoo	4A Howard	4A Ripley	5B White Pine	3B Doña Ana
MISSOURI	4A Howell	4A Saline	NEW	3B Eddy
5A Adair	4A Iron	5A Schuyler	HAMPSHIRE	4B Grant
5A Andrew	4A Jackson	5A Scotland	6A Belknap	4B Guadalupe
5A Atchison	4A Jasper	4A Scott	6A Carroll	5B Harding
4A Audrain	4A Jefferson	4A Shannon	5A Cheshire	3B Hidalgo
4A Barry	4A Johnson	5A Shelby	6A Coos	3B Lea
4A Barton	5A Knox	4A St. Charles	6A Grafton	4B Lincoln
4A Bates	4A Laclede	4A St. Clair	5A Hillsborough	5B Los Alamos
4A Benton	4A Lafayette	4A St. Francois	6A Merrimack	3B Luna
4A Bollinger	4A Lawrence	4A St. Louis	5A Rockingham	5B McKinley
4A Boone	5A Lewis	4A St. Louis (city)	5A Strafford	5B Mora
5A Buchanan	4A Lincoln	4A Ste. Genevieve	6A Sullivan	3B Otero
4A Butler	5A Linn	4A Stoddard	4A Atlantic	4B Quay
5A Caldwell	5A Livingston	4A Stone	5A Bergen	5B Rio Arriba
4A Callaway	5A Macon	5A Sullivan	4A Burlington	4B Roosevelt
4A Camden	4A Madison	4A Taney	4A Camden	5B Sandoval
4A Cape Girardeau	4A Maries	4A Texas	4A Cape May	5B San Juan
4A Carroll	5A Marion	4A Vernon		5B San Miguel
4A Carter	4A McDonald	4A Warren		5B Santa Fe
4A Cass	5A Mercer	4A Washington		4B Sierra
4A Cedar	4A Miller	4A Wayne		4B Socorro

(continued)

GENERAL REQUIREMENTS

TABLE C301.1—continued
CLIMATE ZONES, MOISTURE REGIMES, AND WARM-HUMID
DESIGNATIONS BY STATE, COUNTY AND TERRITORY

5B Taos	4A Queens	4A Clay	4A Orange	7 Divide
5B Torrance	5A Rensselaer	4A Cleveland	3A Pamlico	6A Dunn
4B Union	4A Richmond	3A Columbus*	3A Pasquotank	7 Eddy
4B Valencia	5A Rockland	3A Craven	3A Pender*	6A Emmons
NEW YORK	5A Saratoga	3A Cumberland	3A Perquimans	7 Foster
5A Albany	5A Schenectady	3A Currituck	4A Person	6A Golden Valley
6A Allegany	6A Schoharie	3A Dare	3A Pitt	7 Grand Forks
4A Bronx	6A Schuyler	3A Davidson	4A Polk	6A Grant
6A Broome	5A Seneca	4A Davie	3A Randolph	7 Griggs
6A Cattaraugus	6A Steuben	3A Duplin	3A Richmond	6A Hettinger
5A Cayuga	6A St. Lawrence	4A Durham	3A Robeson	7 Kidder
5A Chautauqua	4A Suffolk	3A Edgecombe	4A Rockingham	6A LaMoure
5A Chemung	6A Sullivan	4A Forsyth	3A Rowan	6A Logan
6A Chenango	5A Tioga	4A Franklin	4A Rutherford	7 McHenry
6A Clinton	6A Tompkins	3A Gaston	3A Sampson	6A McIntosh
5A Columbia	6A Ulster	4A Gates	3A Scotland	6A McKenzie
5A Cortland	6A Warren	4A Graham	3A Stanly	7 McLean
6A Delaware	5A Washington	4A Granville	4A Stokes	6A Mercer
5A Dutchess	5A Wayne	3A Greene	4A Surry	6A Morton
5A Erie	4A Westchester	4A Guilford	4A Swain	7 Mountrail
6A Essex	6A Wyoming	4A Halifax	4A Transylvania	7 Nelson
6A Franklin	5A Yates	4A Harnett	3A Tyrrell	6A Oliver
6A Fulton	NORTH	4A Haywood	3A Union	7 Pembina
5A Genesee	CAROLINA	4A Henderson	4A Vance	7 Pierce
5A Greene	4A Alamance	4A Hertford	4A Wake	7 Ramsey
6A Hamilton	4A Alexander	3A Hoke	4A Warren	6A Ransom
6A Herkimer	5A Alleghany	3A Hyde	3A Washington	7 Renville
6A Jefferson	3A Anson	4A Iredell	5A Watauga	6A Richland
4A Kings	5A Ashe	4A Jackson	3A Wayne	7 Rolette
6A Lewis	5A Avery	3A Johnston	4A Wilkes	6A Sargent
5A Livingston	3A Beaufort	4A Lee	3A Wilson	7 Sheridan
6A Madison	4A Bertie	3A Lenoir	4A Yadkin	6A Sioux
5A Monroe	3A Bladen	4A Lincoln	5A Yancey	6A Slope
6A Montgomery	3A Brunswick*	4A Macon	NORTH DAKOTA	6A Stark
4A Nassau	4A Buncombe	4A Madison	6A Adams	7 Steele
4A New York	4A Burke	3A Martin	7 Barnes	7 Stutsman
5A Niagara	3A Cabarrus	4A McDowell	7 Benson	7 Towner
6A Oneida	4A Caldwell	3A Mecklenburg	6A Billings	7 Traill
5A Onondaga	3A Camden	5A Mitchell	7 Bottineau	7 Walsh
5A Ontario	3A Carteret*	3A Montgomery	6A Bowman	7 Ward
5A Orange	4A Caswell	3A Moore	7 Burke	7 Wells
5A Orleans	4A Catawba	4A Nash	6A Burleigh	7 Williams
5A Oswego	4A Chatham	3A New Hanover*	7 Cass	OHIO
6A Otsego	4A Cherokee	4A Northampton	7 Cavalier	4A Adams
5A Putnam	3A Chowan	3A Onslow*	6A Dickey	5A Allen

(continued)

TABLE C301.1—continued
CLIMATE ZONES, MOISTURE REGIMES, AND WARM-HUMID
DESIGNATIONS BY STATE, COUNTY AND TERRITORY

5A Ashland	5A Mahoning	3A Bryan	3A Okfuskee	4C Linn
5A Ashtabula	5A Marion	3A Caddo	3A Oklahoma	5B Malheur
5A Athens	5A Medina	3A Canadian	3A Okmulgee	4C Marion
5A Auglaize	5A Meigs	3A Carter	3A Osage	5B Morrow
5A Belmont	5A Mercer	3A Cherokee	3A Ottawa	4C Multnomah
4A Brown	5A Miami	3A Choctaw	3A Pawnee	4C Polk
5A Butler	5A Monroe	4B Cimarron	3A Payne	5B Sherman
5A Carroll	5A Montgomery	3A Cleveland	3A Pittsburg	4C Tillamook
5A Champaign	5A Morgan	3A Coal	3A Pontotoc	5B Umatilla
5A Clark	5A Morrow	3A Comanche	3A Pottawatomie	5B Union
4A Clermont	5A Muskingum	3A Cotton	3A Pushmataha	5B Wallowa
5A Clinton	5A Noble	3A Craig	3A Roger Mills	5B Wasco
5A Columbiana	5A Ottawa	3A Creek	3A Rogers	4C Washington
5A Coshocton	5A Paulding	3A Custer	3A Seminole	5B Wheeler
5A Crawford	5A Perry	3A Delaware	3A Sequoyah	4C Yamhill
5A Cuyahoga	5A Pickaway	3A Dewey	3A Stephens	
5A Darke	4A Pike	3A Ellis	4B Texas	PENNSYLVANIA
5A Defiance	5A Portage	3A Garfield	3A Tillman	5A Adams
5A Delaware	5A Preble	3A Garvin	3A Tulsa	5A Allegheny
5A Erie	5A Putnam	3A Grady	3A Wagoner	5A Armstrong
5A Fairfield	5A Richland	3A Grant	3A Washington	5A Beaver
5A Fayette	5A Ross	3A Greer	3A Washita	5A Bedford
5A Franklin	5A Sandusky	3A Harmon	3A Woods	5A Berks
5A Fulton	4A Scioto	3A Harper	3A Woodward	5A Blair
4A Gallia	5A Seneca	3A Haskell		5A Bradford
5A Geauga	5A Shelby	3A Hughes	OREGON	4A Bucks
5A Greene	5A Stark	3A Jackson	5B Baker	5A Butler
5A Guernsey	5A Summit	3A Jefferson	4C Benton	5A Cambria
4A Hamilton	5A Trumbull	3A Johnston	4C Clackamas	6A Cameron
5A Hancock	5A Tuscarawas	3A Kay	4C Clatsop	5A Carbon
5A Hardin	5A Union	3A Kingfisher	4C Columbia	5A Centre
5A Harrison	5A Van Wert	3A Kiowa	4C Coos	4A Chester
5A Henry	5A Vinton	3A Latimer	5B Crook	5A Clarion
5A Highland	5A Warren	3A Le Flore	4C Curry	6A Clearfield
5A Hocking	4A Washington	3A Lincoln	5B Deschutes	5A Clinton
5A Holmes	5A Wayne	3A Logan	4C Douglas	5A Columbia
5A Huron	5A Williams	3A Love	5B Gilliam	5A Crawford
5A Jackson	5A Wood	3A Major	5B Grant	5A Cumberland
5A Jefferson	5A Wyandot	3A Marshall	5B Harney	5A Dauphin
5A Knox		3A Mayes	5B Hood River	4A Delaware
5A Lake	OKLAHOMA	3A McClain	4C Jackson	6A Elk
4A Lawrence	3A Adair	3A McCurtain	5B Jefferson	5A Erie
5A Licking	3A Alfalfa	3A McIntosh	4C Josephine	5A Fayette
5A Logan	3A Atoka	3A Murray	5B Klamath	5A Forest
5A Lorain	4B Beaver	3A Muskogee	5B Lake	5A Franklin
5A Lucas	3A Beckham	3A Noble	4C Lane	5A Fulton
5A Madison	3A Blaine	3A Nowata	4C Lincoln	5A Greene

(continued)

GENERAL REQUIREMENTS

**TABLE C301.1—continued
CLIMATE ZONES, MOISTURE REGIMES, AND WARM-HUMID
DESIGNATIONS BY STATE, COUNTY AND TERRITORY**

5A Huntingdon	3A Bamberg*	5A Bennett	6A Minnehaha	4A Gibson
5A Indiana	3A Barnwell*	5A Bon Homme	6A Moody	4A Giles
5A Jefferson	3A Beaufort*	6A Brookings	6A Pennington	4A Grainger
5A Juniata	3A Berkeley*	6A Brown	6A Perkins	4A Greene
5A Lackawanna	3A Calhoun	6A Brule	6A Potter	4A Grundy
5A Lancaster	3A Charleston*	6A Buffalo	6A Roberts	4A Hamblen
5A Lawrence	3A Cherokee	6A Butte	6A Sanborn	4A Hamilton
5A Lebanon	3A Chester	6A Campbell	6A Shannon	4A Hancock
5A Lehigh	3A Chesterfield	5A Charles Mix	6A Spink	3A Hardeman
5A Luzerne	3A Clarendon	6A Clark	6A Stanley	3A Hardin
5A Lycoming	3A Colleton*	5A Clay	6A Sully	4A Hawkins
6A McKean	3A Darlington	6A Codrington	5A Todd	3A Haywood
5A Mercer	3A Dillon	6A Corson	5A Tripp	3A Henderson
5A Mifflin	3A Dorchester*	6A Custer	6A Turner	4A Henry
5A Monroe	3A Edgefield	6A Davison	5A Union	4A Hickman
4A Montgomery	3A Fairfield	6A Day	6A Walworth	4A Houston
5A Montour	3A Florence	6A Deuel	5A Yankton	4A Humphreys
5A Northampton	3A Georgetown*	6A Dewey	6A Ziebach	4A Jackson
5A Northumberland	3A Greenville	5A Douglas	TENNESSEE	4A Jefferson
5A Perry	3A Greenwood	6A Edmunds	4A Anderson	4A Johnson
4A Philadelphia	3A Hampton*	6A Fall River	4A Bedford	4A Knox
5A Pike	3A Horry*	6A Faulk	4A Benton	3A Lake
6A Potter	3A Jasper*	6A Grant	4A Bledsoe	3A Lauderdale
5A Schuylkill	3A Kershaw	5A Gregory	4A Blount	4A Lawrence
5A Snyder	3A Lancaster	6A Haakon	4A Bradley	4A Lewis
5A Somerset	3A Laurens	6A Hamlin	4A Campbell	4A Lincoln
5A Sullivan	3A Lee	6A Hand	4A Cannon	4A Loudon
6A Susquehanna	3A Lexington	6A Hanson	4A Carroll	4A Macon
6A Tioga	3A Marion	6A Harding	4A Carter	3A Madison
5A Union	3A Marlboro	6A Hughes	4A Cheatham	4A Marion
5A Venango	3A McCormick	5A Hutchinson	3A Chester	4A Marshall
5A Warren	3A Newberry	6A Hyde	4A Claiborne	4A Maury
5A Washington	3A Oconee	5A Jackson	4A Clay	4A McMinn
6A Wayne	3A Orangeburg	6A Jerauld	4A Coker	3A McNairy
5A Westmoreland	3A Pickens	6A Jones	4A Coffee	4A Meigs
5A Wyoming	3A Richland	6A Kingsbury	3A Crockett	4A Monroe
4A York	3A Saluda	6A Lake	4A Cumberland	4A Montgomery
RHODE ISLAND	3A Spartanburg	6A Lawrence	4A Davidson	4A Moore
5A (all)	3A Sumter	6A Lincoln	4A Decatur	4A Morgan
SOUTH	3A Union	6A Lyman	4A DeKalb	4A Obion
CAROLINA	3A Williamsburg	6A Marshall	4A Dickson	4A Overton
3A Abbeville	3A York	6A McCook	3A Dyer	4A Perry
3A Aiken	SOUTH DAKOTA	6A McPherson	3A Fayette	4A Pickett
3A Allendale*	6A Aurora	6A Meade	4A Fentress	4A Polk
3A Anderson	6A Beadle	5A Mellette	4A Franklin	4A Putnam
		6A Miner		4A Rhea

(continued)

TABLE C301.1—continued
CLIMATE ZONES, MOISTURE REGIMES, AND WARM-HUMID
DESIGNATIONS BY STATE, COUNTY AND TERRITORY

4A Roane	3B Brewster	3B Ector	3B Howard	3B McCulloch
4A Robertson	4B Briscoe	2B Edwards	3B Hudspeth	2A McLennan*
4A Rutherford	2A Brooks*	3A Ellis*	3A Hunt*	2A McMullen*
4A Scott	3A Brown*	3B El Paso	4B Hutchinson	2B Medina
4A Sequatchie	2A Burlison*	3A Erath*	3B Irion	3B Menard
4A Sevier	3A Burnet*	2A Falls*	3A Jack	3B Midland
3A Shelby	2A Caldwell*	3A Fannin	2A Jackson*	2A Milam*
4A Smith	2A Calhoun*	2A Fayette*	2A Jasper*	3A Mills*
4A Stewart	3B Callahan	3B Fisher	3B Jeff Davis	3B Mitchell
4A Sullivan	2A Cameron*	4B Floyd	2A Jefferson*	3A Montague
4A Sumner	3A Camp*	3B Foard	2A Jim Hogg*	2A Montgomery*
3A Tipton	4B Carson	2A Fort Bend*	2A Jim Wells*	4B Moore
4A Trousdale	3A Cass*	3A Franklin*	3A Johnson*	3A Morris*
4A Unicoi	4B Castro	2A Freestone*	3B Jones	3B Motley
4A Union	2A Chambers*	2B Frio	2A Karnes*	3A Nacogdoches*
4A Van Buren	2A Cherokee*	3B Gaines	3A Kaufman*	3A Navarro*
4A Warren	3B Childress	2A Galveston*	3A Kendall*	2A Newton*
4A Washington	3A Clay	3B Garza	2A Kenedy*	3B Nolan
4A Wayne	4B Cochran	3A Gillespie*	3B Kent	2A Nueces*
4A Weakley	3B Coke	3B Glasscock	3B Kerr	4B Ochiltree
4A White	3B Coleman	2A Goliad*	3B Kimble	4B Oldham
4A Williamson	3A Collin*	2A Gonzales*	3B King	2A Orange*
4A Wilson	3B Collingsworth	4B Gray	2B Kinney	3A Palo Pinto*
TEXAS	2A Colorado*	3A Grayson	2A Kleberg*	3A Panola*
2A Anderson*	2A Comal*	3A Gregg*	3B Knox	3A Parker*
3B Andrews	3A Comanche*	2A Grimes*	3A Lamar*	4B Parmer
2A Angelina*	3B Concho	2A Guadalupe*	4B Lamb	3B Pecos
2A Aransas*	3A Cooke	4B Hale	3A Lampasas*	2A Polk*
3A Archer	2A Coryell*	3B Hall	2B La Salle	4B Potter
4B Armstrong	3B Cottle	3A Hamilton*	2A Lavaca*	3B Presidio
2A Atascosa*	3B Crane	4B Hansford	2A Lee*	3A Rains*
2A Austin*	3B Crockett	3B Hardeman	2A Leon*	4B Randall
4B Bailey	3B Crosby	2A Hardin*	2A Liberty*	3B Reagan
2B Bandera	3B Culberson	2A Harris*	2A Limestone*	2B Real
2A Bastrop*	4B Dallam	3A Harrison*	4B Lipscomb	3A Red River*
3B Baylor	3A Dallas*	4B Hartley	2A Live Oak*	3B Reeves
2A Bee*	3B Dawson	3B Haskell	3A Llano*	2A Refugio*
2A Bell*	4B Deaf Smith	2A Hays*	3B Loving	4B Roberts
2A Bexar*	3A Delta	3B Hemphill	3B Lubbock	2A Robertson*
3A Blanco*	3A Denton*	3A Henderson*	3B Lynn	3A Rockwall*
3B Borden	2A DeWitt*	2A Hidalgo*	2A Madison*	3B Runnels
2A Bosque*	3B Dickens	2A Hill*	3A Marion*	3A Rusk*
3A Bowie*	2B Dimmit	4B Hockley	3B Martin	3A Sabine*
2A Brazoria*	4B Donley	3A Hood*	3B Mason	3A San Augustine*
2A Brazos*	2A Duval*	3A Hopkins*	2A Matagorda*	2A San Jacinto*
	3A Eastland	2A Houston*	2B Maverick	2A San Patricio*

(continued)

GENERAL REQUIREMENTS

**TABLE C301.1—continued
CLIMATE ZONES, MOISTURE REGIMES, AND WARM-HUMID
DESIGNATIONS BY STATE, COUNTY AND TERRITORY**

3A San Saba*	3A Young	4C Clark	4A Gilmer	WISCONSIN
3B Schleicher	2B Zapata	5B Columbia	5A Grant	
3B Scurry	2B Zavala	4C Cowlitz	5A Greenbrier	
3B Shackelford		5B Douglas	5A Hampshire	
3A Shelby*	UTAH	6B Ferry	5A Hancock	
4B Sherman	5B Beaver	5B Franklin	5A Hardy	
3A Smith*	6B Box Elder	5B Garfield	5A Harrison	
3A Somervell*	6B Cache	5B Grant	4A Jackson	
2A Starr*	6B Carbon	4C Grays Harbor	4A Jefferson	
3A Stephens	6B Daggett	4C Island	4A Kanawha	
3B Sterling	5B Davis	4C Jefferson	5A Lewis	
3B Stonewall	6B Duchesne	4C King	4A Lincoln	
3B Sutton	5B Emery	4C Kitsap	4A Logan	
4B Swisher	5B Garfield	5B Kittitas	5A Marion	
3A Tarrant*	5B Grand	5B Klickitat	5A Marshall	
3B Taylor	5B Iron	4C Lewis	4A Mason	
3B Terrell	5B Juab	5B Lincoln	4A McDowell	
3B Terry	5B Kane	4C Mason	4A Mercer	
3B Throckmorton	5B Millard	6B Okanogan	5A Mineral	
3A Titus*	6B Morgan	4C Pacific	4A Mingo	
3B Tom Green	5B Piute	6B Pend Oreille	5A Monongalia	
2A Travis*	6B Rich	4C Pierce	4A Monroe	
2A Trinity*	5B Salt Lake	4C San Juan	4A Morgan	
2A Tyler*	5B San Juan	4C Skagit	5A Nicholas	
3A Upshur*	5B Sanpete	5B Skamania	5A Ohio	
3B Upton	5B Sevier	4C Snohomish	5A Pendleton	
2B Uvalde	6B Summit	5B Spokane	4A Pleasants	
2B Val Verde	5B Tooele	6B Stevens	5A Pocahontas	
3A Van Zandt*	6B Uintah	4C Thurston	5A Preston	
2A Victoria*	5B Utah	4C Wahkiakum	4A Putnam	
2A Walker*	6B Wasatch	5B Walla Walla	5A Raleigh	
2A Waller*	3B Washington	4C Whatcom	5A Randolph	
3B Ward	5B Wayne	5B Whitman	4A Ritchie	
2A Washington*	5B Weber	5B Yakima	4A Roane	
2B Webb	VERMONT	WEST VIRGINIA	5A Summers	
2A Wharton*	6A (all)	5A Barbour	5A Taylor	
3B Wheeler	VIRGINIA	4A Berkeley	5A Tucker	
3A Wichita	4A (all)	4A Boone	4A Tyler	
3B Wilbarger	WASHINGTON	4A Braxton	5A Upshur	
2A Willacy*	5B Adams	5A Brooke	4A Wayne	
2A Williamson*	5B Asotin	4A Cabell	5A Webster	
2A Wilson*	5B Benton	4A Calhoun	5A Wetzel	
3B Winkler	5B Benton	4A Clay	4A Wirt	
3A Wise	5B Chelan	5A Doddridge	4A Wood	
3A Wood*	4C Clallam	5A Fayette	4A Wyoming	
4B Yoakum				

(continued)

TABLE C301.1—continued
CLIMATE ZONES, MOISTURE REGIMES, AND WARM-HUMID
DESIGNATIONS BY STATE, COUNTY AND TERRITORY

6A Ozaukee	7 Taylor	6B Big Horn	6B Sheridan	NORTHERN MARIANA ISLANDS
6A Pepin	6A Trempealeau	6B Campbell	7 Sublette	
6A Pierce	6A Vernon	6B Carbon	6B Sweetwater	1A (all)*
6A Polk	7 Vilas	6B Converse	7 Teton	PUERTO RICO
6A Portage	6A Walworth	6B Crook	6B Uinta	
7 Price	7 Washburn	6B Fremont	6B Washakie	1A (all)*
6A Racine	6A Washington	5B Goshen	6B Weston	VIRGIN ISLANDS
6A Richland	6A Waukesha	6B Hot Springs		
6A Rock	6A Waupaca	6B Johnson	US TERRITORIES	1A (all)*
6A Rusk	6A Waushara	6B Laramie	AMERICAN	
6A Sauk	6A Winnebago	7 Lincoln	SAMOA	
7 Sawyer	6A Wood	6B Natrona	1A (all)*	
6A Shawano	WYOMING	6B Niobrara	GUAM	
6A Sheboygan	6B Albany	6B Park	1A (all)*	
6A St. Croix		5B Platte		

TABLE C301.3(1)
INTERNATIONAL CLIMATE ZONE DEFINITIONS

MAJOR CLIMATE TYPE DEFINITIONS
<p>Marine (C) Definition—Locations meeting all four criteria:</p> <ol style="list-style-type: none"> 1. Mean temperature of coldest month between -3°C (27°F) and 18°C (65°F). 2. Warmest month mean < 22°C (72°F). 3. At least four months with mean temperatures over 10°C (50°F). 4. Dry season in summer. The month with the heaviest precipitation in the cold season has at least three times as much precipitation as the month with the least precipitation in the rest of the year. The cold season is October through March in the Northern Hemisphere and April through September in the Southern Hemisphere.
<p>Dry (B) Definition—Locations meeting the following criteria:</p> <p>Not marine and $P_{in} < 0.44 \times (TF - 19.5)$ [$P_{cm} < 2.0 \times (TC + 7)$ in SI units]</p> <p>where:</p> <p>P_{in} = Annual precipitation in inches (cm)</p> <p>T = Annual mean temperature in °F (°C)</p>
<p>Moist (A) Definition—Locations that are not marine and not dry.</p>
<p>Warm-humid Definition—Moist (A) locations where either of the following wet-bulb temperature conditions shall occur during the warmest six consecutive months of the year:</p> <ol style="list-style-type: none"> 1. 67°F (19.4°C) or higher for 3,000 or more hours; or 2. 73°F (22.8°C) or higher for 1,500 or more hours.

For SI: °C = [(°F) - 32]/1.8, 1 inch = 2.54 cm.

GENERAL REQUIREMENTS

TABLE C301.3(2)
INTERNATIONAL CLIMATE ZONE DEFINITIONS

ZONE NUMBER	THERMAL CRITERIA	
	IP Units	SI Units
1	9000 < CDD50°F	5000 < CDD10°C
2	6300 < CDD50°F ≤ 9000	3500 < CDD10°C ≤ 5000
3A and 3B	4500 < CDD50°F ≤ 6300 AND HDD65°F ≤ 5400	2500 < CDD10°C ≤ 3500 AND HDD18°C ≤ 3000
4A and 4B	CDD50°F ≤ 4500 AND HDD65°F ≤ 5400	CDD10°C ≤ 2500 AND HDD18°C ≤ 3000
3C	HDD65°F ≤ 3600	HDD18°C ≤ 2000
4C	3600 < HDD65°F ≤ 5400	2000 < HDD18°C ≤ 3000
5	5400 < HDD65°F ≤ 7200	3000 < HDD18°C ≤ 4000
6	7200 < HDD65°F ≤ 9000	4000 < HDD18°C ≤ 5000
7	9000 < HDD65°F ≤ 12600	5000 < HDD18°C ≤ 7000
8	12600 < HDD65°F	7000 < HDD18°C

For SI: °C = [(°F) - 32]/1.8.

SECTION C302 DESIGN CONDITIONS

C302.1 Interior design conditions. The interior design temperatures used for heating and cooling load calculations shall be a maximum of 72°F (22°C) for heating and minimum of 75°F (24°C) for cooling.

SECTION C303 MATERIALS, SYSTEMS AND EQUIPMENT

C303.1 Identification. Materials, systems and equipment shall be identified in a manner that will allow a determination of compliance with the applicable provisions of this code.

C303.1.1 Building thermal envelope insulation. An *R*-value identification mark shall be applied by the manufacturer to each piece of *building thermal envelope* insulation 12 inches (305 mm) or greater in width. Alternatively, the insulation installers shall provide a certification listing the type, manufacturer and *R*-value of insulation installed in each element of the *building thermal envelope*. For blown-in or sprayed fiberglass and cellulose insulation, the initial installed thickness, settled thickness, settled *R*-value, installed density, coverage area and number of bags installed shall be *listed* on the certification. For sprayed polyurethane foam (SPF) insulation, the installed thickness of the areas covered and *R*-value of installed thickness shall be *listed* on the certification. For insulated siding, the *R*-value shall be labeled on the product's package and shall be *listed* on the certification. The insulation installer shall sign, date and post the certification in a conspicuous location on the job site.

Exception: For roof insulation installed above the deck, the *R*-value shall be labeled as required by the material standards specified in Table 1508.2 of the *International Building Code*.

C303.1.1.1 Blown-in or sprayed roof/ceiling insulation. The thickness of blown-in or sprayed fiberglass and cellulose roof/ceiling insulation shall be written in inches (mm) on markers and one or more of such markers shall be installed for every 300 square feet (28 m²) of attic area throughout the attic space. The markers shall be affixed to the trusses or joists and marked with the minimum initial installed thickness with numbers not less than 1 inch (25 mm) in height. Each marker shall face the attic *access* opening. Spray polyurethane foam thickness and installed *R*-value shall be *listed* on certification provided by the insulation installer.

C303.1.2 Insulation mark installation. Insulating materials shall be installed such that the manufacturer's *R*-value mark is readily observable upon inspection.

C303.1.3 Fenestration product rating. *U*-factors of fenestration products shall be determined as follows:

1. For windows, doors and skylights, *U*-factor ratings shall be determined in accordance with NFRC 100.
2. Where required for garage doors and rolling doors, *U*-factor ratings shall be determined in accordance with either NFRC 100 or ANSI/DASMA 105.

U-factors shall be determined by an accredited, independent laboratory, and *labeled* and certified by the manufacturer.

Products lacking such a *labeled U*-factor shall be assigned a default *U*-factor from Table C303.1.3(1) or C303.1.3(2). The solar heat gain coefficient (SHGC) and *visible transmittance* (VT) of glazed fenestration products (windows, glazed doors and skylights) shall be determined in accordance with NFRC 200 by an accredited, independent laboratory, and *labeled* and certified by the manufacturer. Products lacking such a *labeled* SHGC or VT shall be assigned a default SHGC or VT from Table C303.1.3(3).

**TABLE C303.1.3(1)
DEFAULT GLAZED WINDOW,
GLASS DOOR AND SKYLIGHT U-FACTORS**

FRAME TYPE	WINDOW AND GLASS DOOR		SKYLIGHT	
	Single	Double	Single	Double
Metal	1.20	0.80	2.00	1.30
Metal with Thermal Break	1.10	0.65	1.90	1.10
Nonmetal or Metal Clad	0.95	0.55	1.75	1.05
Glazed Block	0.60			

Section C303.2. Where the continuous insulation board manufacturer’s instructions do not address installation of two or more layers, the edge joints between each layer of continuous insulation boards shall be staggered.

**TABLE C303.1.3(2)
DEFAULT OPAQUE DOOR U-FACTORS**

DOOR TYPE	OPAQUE U-FACTOR
Uninsulated Metal	1.20
Insulated Metal (Rolling)	0.90
Insulated Metal (Other)	0.60
Wood	0.50
Insulated, nonmetal edge, max 45% glazing, any glazing double pane	0.35

**TABLE C303.1.3(3)
DEFAULT GLAZED FENESTRATION SHGC AND VT**

	SINGLE GLAZED		DOUBLE GLAZED		GLAZED BLOCK
	Clear	Tinted	Clear	Tinted	
SHGC	0.8	0.7	0.7	0.6	0.6
VT	0.6	0.3	0.6	0.3	0.6

C303.1.4 Insulation product rating. The thermal resistance (*R*-value) of insulation shall be determined in accordance with the U.S. Federal Trade Commission *R*-value rule (CFR Title 16, Part 460) in units of $h \cdot ft^2 \cdot ^\circ F/Btu$ at a mean temperature of 75°F (24°C).

C303.1.4.1 Insulated siding. The thermal resistance (*R*-value) of insulated siding shall be determined in accordance with ASTM C1363. Installation for testing shall be in accordance with the manufacturer’s instructions.

C303.2 Installation. Materials, systems and equipment shall be installed in accordance with the manufacturer’s instructions and the *International Building Code*.

C303.2.1 Protection of exposed foundation insulation. Insulation applied to the exterior of basement walls, crawl space walls and the perimeter of slab-on-grade floors shall have a rigid, opaque and weather-resistant protective covering to prevent the degradation of the insulation’s thermal performance. The protective covering shall cover the exposed exterior insulation and extend not less than 6 inches (153 mm) below grade.

C303.2.2 Multiple layers of continuous insulation board. Where two or more layers of continuous insulation board are used in a construction assembly, the continuous insulation boards shall be installed in accordance with

CHAPTER 4 [CE]

COMMERCIAL ENERGY EFFICIENCY

User note:

About this chapter: Chapter 4 presents the paths and options for compliance with the energy efficiency provisions. Chapter 4 contains energy efficiency provisions for the building envelope, fenestration, mechanical systems, appliances, freezers and coolers, kitchen exhaust, interior and exterior lighting, water heating systems, transformers and motors.

SECTION C401 GENERAL

C401.1 Scope. The provisions in this chapter are applicable to commercial *buildings* and their *building sites*.

C401.2 Application. Commercial buildings shall comply with one of the following:

1. The requirements of ANSI/ASHRAE/IESNA 90.1.
2. The requirements of Sections C402 through C405 and C408. In addition, commercial buildings shall comply with Section C406 and tenant spaces shall comply with Section C406.1.1.
3. The requirements of Sections C402.5, C403.2, C403.3 through C403.3.2, C403.4 through C403.4.2.3, C403.5.5, C403.7, C403.8.1 through C403.8.4, C403.10.1 through C403.10.3, C403.11, C403.12, C404, C405, C407 and C408. The building energy cost shall be equal to or less than 85 percent of the standard reference design building.

C401.2.1 Application to replacement fenestration products. Where some or all of an existing *fenestration* unit is replaced with a new *fenestration* product, including sash and glazing, the replacement *fenestration* unit shall meet the applicable requirements for *U*-factor and *SHGC* in Table C402.4.

Exception: An area-weighted average of the *U*-factor of replacement fenestration products being installed in the building for each fenestration product category listed in Table C402.4 shall be permitted to satisfy the *U*-factor requirements for each fenestration product category listed in Table C402.4. Individual fenestration products from different product categories listed in Table C402.4 shall not be combined in calculating the area-weighted average *U*-factor.

SECTION C402 BUILDING ENVELOPE REQUIREMENTS

C402.1 General (Prescriptive). Building thermal envelope assemblies for buildings that are intended to comply with the code on a prescriptive basis in accordance with the compliance path described in Item 2 of Section C401.2, shall comply with the following:

1. The opaque portions of the building thermal envelope shall comply with the specific insulation requirements of Section C402.2 and the thermal requirements of either the

R-value-based method of Section C402.1.3; the *U*-, *C*- and *F*-factor-based method of Section C402.1.4; or the component performance alternative of Section C402.1.5.

2. Roof solar reflectance and thermal emittance shall comply with Section C402.3.
3. Fenestration in building envelope assemblies shall comply with Section C402.4.
4. Air leakage of building envelope assemblies shall comply with Section C402.5.

Alternatively, where buildings have a vertical fenestration area or skylight area exceeding that allowed in Section C402.4, the building and building thermal envelope shall comply with Section C401.2, Item 1 or Section C401.2, Item 3.

Walk-in coolers, walk-in freezers, refrigerated warehouse coolers and refrigerated warehouse freezers shall comply with Section C403.10.1 or C403.10.2.

C402.1.1 Low-energy buildings. The following low-energy buildings, or portions thereof separated from the remainder of the building by *building thermal envelope* assemblies complying with this section, shall be exempt from the *building thermal envelope* provisions of Section C402.

1. Those with a peak design rate of energy usage less than 3.4 Btu/h • ft² (10.7 W/m²) or 1.0 watt per square foot (10.7 W/m²) of floor area for space conditioning purposes.
2. Those that do not contain *conditioned space*.
3. Greenhouses.

C402.1.2 Equipment buildings. Buildings that comply with the following shall be exempt from the *building thermal envelope* provisions of this code:

1. Are separate buildings with floor area not more than 500 square feet (50 m²).
2. Are intended to house electronic equipment with installed equipment power totaling not less than 7 watts per square foot (75 W/m²) and not intended for human occupancy.
3. Have a heating system capacity not greater than (17,000 Btu/hr) (5 kW) and a heating thermostat set-point that is restricted to not more than 50°F (10°C).
4. Have an average wall and roof *U*-factor less than 0.200 in *Climate Zones* 1 through 5 and less than 0.120 in *Climate Zones* 6 through 8.
5. Comply with the roof solar reflectance and thermal emittance provisions for *Climate Zone* 1.

C402.1.3 Insulation component R-value-based method.

Building thermal envelope opaque assemblies shall comply with the requirements of Sections C402.2 and C402.4 based on the *climate zone* specified in Chapter 3. For opaque portions of the *building thermal envelope* intended to comply on an insulation component *R-value* basis, the *R-values* for insulation shall be not less than that specified in Table C402.1.3. Commercial buildings or portions of commercial buildings enclosing *Group R* occupancies shall use the *R-values* from the “*Group R*” column of Table C402.1.3. Commercial buildings or portions of commercial buildings enclosing occupancies other than *Group R* shall use the *R-values* from the “All other” column of Table C402.1.3.

C402.1.4 Assembly U-factor, C-factor or F-factor-based method.

Building thermal envelope opaque assemblies shall meet the requirements of Sections C402.2 and C402.4 based on the *climate zone* specified in Chapter 3. Building thermal envelope opaque assemblies intended to comply on an assembly *U-, C- or F-factor* basis shall have a *U-, C- or F-factor* not greater than that specified in Table C402.1.4. Commercial buildings or portions of commercial buildings enclosing *Group R* occupancies shall use the *U-, C- or F-factor* from the “*Group R*” column of Table C402.1.4. Commercial buildings or portions of commercial buildings enclosing occupancies other than *Group R* shall use the *U-, C- or F-factor* from the “All other” column of Table C402.1.4

C402.1.4.1 Thermal resistance of cold-formed steel walls.

U-factors of walls with cold-formed steel studs shall be permitted to be determined in accordance with Equation 4-1:

$$U = 1/[R_s + (ER)] \tag{Equation 4-1}$$

where:

R_s = The cumulative *R-value* of the wall components along the path of heat transfer, excluding the *cavity insulation* and steel studs.

ER = The effective *R-value* of the *cavity insulation* with steel studs as specified in Table C402.1.4.1.

C402.1.5 Component performance alternative. Building envelope values and fenestration areas determined in accordance with Equation 4-2 shall be an alternative to compliance with the *U-, F- and C-factors* in Tables

C402.1.4 and C402.4 and the maximum allowable fenestration areas in Section C402.4.1. *Fenestration* shall meet the applicable SHGC requirements of Section C402.4.3.

$$A + B + C + D + E \leq \text{Zero} \tag{Equation 4-2}$$

where:

A = Sum of the (UA Dif) values for each distinct assembly type of the building thermal envelope, other than slabs on grade and below-grade walls.

UA Dif = UA Proposed - UA Table.

UA Proposed = Proposed *U-value* × Area.

UA Table = (*U-factor* from Table C402.1.3, C402.1.4 or C402.4 × Area.

B = Sum of the (FL Dif) values for each distinct slab-on-grade perimeter condition of the building thermal envelope.

FL Dif = FL Proposed - FL Table.

FL Proposed = Proposed *F-value* × Perimeter length.

FL Table = (*F-factor* specified in Table C402.1.4) × Perimeter length.

C = Sum of the (CA Dif) values for each distinct below-grade wall assembly type of the building thermal envelope.

CA Dif = CA Proposed - CA Table.

CA Proposed = Proposed *C-value* × Area.

CA Table = (Maximum allowable *C-factor* specified in Table C402.1.4) × Area.

Where the proposed vertical glazing area is less than or equal to the maximum vertical glazing area allowed by Section C402.4.1, the value of D (Excess Vertical Glazing Value) shall be zero. Otherwise:

D = (DA × UV) - (DA × U Wall), but not less than zero.

DA = (Proposed Vertical Glazing Area) - (Vertical Glazing Area allowed by Section C402.4.1).

UA Wall = Sum of the (UA Proposed) values for each opaque assembly of the exterior wall.

TABLE C402.1.4.1
EFFECTIVE R-VALUES FOR STEEL STUD WALL ASSEMBLIES

NOMINAL STUD DEPTH (inches)	SPACING OF FRAMING (inches)	CAVITY R-VALUE (insulation)	CORRECTION FACTOR (F _c)	EFFECTIVE R-VALUE (ER) (Cavity R-Value × F _c)
3 1/2	16	13	0.46	5.98
		15	0.43	6.45
3 1/2	24	13	0.55	7.15
		15	0.52	7.80
6	16	19	0.37	7.03
		21	0.35	7.35
6	24	19	0.45	8.55
		21	0.43	9.03
8	16	25	0.31	7.75
	24	25	0.38	9.50

TABLE C402.1.3 OPAQUE THERMAL ENVELOPE INSULATION COMPONENT MINIMUM REQUIREMENTS, R-VALUE METHOD^{a, i}

CLIMATE ZONE	1		2		3		4 EXCEPT MARINE		5 AND MARINE 4		6		7		8	
	All other	Group R	All other	Group R	All other	Group R	All other	Group R	All other	Group R	All other	Group R	All other	Group R	All other	Group R
Roofs																
Insulation entirely above roof deck	R-20ci	R-25ci	R-25ci	R-30ci	R-25ci	R-30ci	R-30ci	R-30ci	R-30ci	R-30ci	R-30ci	R-30ci	R-30ci	R-35ci	R-35ci	R-35ci
Metal buildings ^b	R-19 + R-11 LS	R-19 + R-11 LS	R-19 + R-11 LS	R-19 + R-11 LS	R-19 + R-11 LS	R-19 + R-11 LS	R-19 + R-11 LS	R-19 + R-11 LS	R-19 + R-11 LS	R-19 + R-11 LS	R-19 + R-11 LS	R-25 + R-11 LS	R-30 + R-11 LS	R-30 + R-11 LS	R-30 + R-11 LS	R-30 + R-11 LS
Attic and other	R-38	R-38	R-38	R-38	R-38	R-38	R-38	R-38	R-38	R-38	R-38	R-49	R-49	R-49	R-49	R-49
Walls, above grade																
Mass ^e	R-5.7ci ^c	R-5.7ci ^c	R-7.6ci	R-9.5ci	R-9.5ci	R-11.4ci	R-11.4ci	R-13.3ci	R-13.3ci	R-13.3ci	R-15.2ci	R-15.2ci	R-15.2ci	R-15.2ci	R-25ci	R-25ci
Metal building	R-13 + R-6.5ci	R-13 + R-6.5ci	R-13 + R-6.5ci	R-13 + R-6.5ci	R-13 + R-6.5ci	R-13 + R-6.5ci	R-13 + R-6.5ci	R-13 + R-6.5ci	R-13 + R-6.5ci	R-13 + R-6.5ci	R-13 + R-6.5ci	R-13 + R-6.5ci	R-13 + R-6.5ci	R-13 + R-6.5ci	R-13 + R-6.5ci	R-13 + R-6.5ci
Metal framed	R-13 + R-5ci	R-13 + R-5ci	R-13 + R-5ci	R-13 + R-5ci	R-13 + R-5ci	R-13 + R-5ci	R-13 + R-5ci	R-13 + R-5ci	R-13 + R-5ci	R-13 + R-5ci	R-13 + R-5ci	R-13 + R-5ci	R-13 + R-5ci	R-13 + R-5ci	R-13 + R-5ci	R-13 + R-5ci
Wood framed and other	R-13 + R-3.8ci or R-20	R-13 + R-3.8ci or R-20	R-13 + R-3.8ci or R-20	R-13 + R-3.8ci or R-20	R-13 + R-3.8ci or R-20	R-13 + R-3.8ci or R-20	R-13 + R-3.8ci or R-20	R-13 + R-3.8ci or R-20	R-13 + R-3.8ci or R-20	R-13 + R-3.8ci or R-20	R-13 + R-3.8ci or R-20	R-13 + R-3.8ci or R-20	R-13 + R-3.8ci or R-20	R-13 + R-3.8ci or R-20	R-13 + R-3.8ci or R-20	R-13 + R-3.8ci or R-20
Walls, below grade																
Below-grade wall ^d	NR	NR	NR	NR	NR	NR	NR	NR	NR	NR	NR	NR	NR	NR	NR	NR
Floors																
Mass ^e	NR	R-6.3ci	R-10ci	R-10ci	R-10ci	R-10.4ci	R-10ci	R-12.5ci	R-12.5ci	R-12.5ci	R-12.5ci	R-12.5ci	R-12.5ci	R-15ci	R-15ci	R-16.7ci
Joist/framing	NR	NR	R-30	R-30	R-30	R-30	R-30	R-30	R-30	R-30	R-30	R-30	R-30	R-30	R-30	R-30
Slab-on-grade floors																
Unheated slabs	NR	NR	NR	NR	NR	NR	NR	NR	NR	NR	NR	NR	NR	NR	NR	NR
Heated slabs ^h	R-7.5 for 12" below + R-5 full slab	R-7.5 for 12" below + R-5 full slab	R-7.5 for 12" below + R-5 full slab	R-7.5 for 12" below + R-5 full slab	R-7.5 for 12" below + R-5 full slab	R-7.5 for 12" below + R-5 full slab	R-7.5 for 12" below + R-5 full slab	R-7.5 for 12" below + R-5 full slab	R-7.5 for 12" below + R-5 full slab	R-7.5 for 12" below + R-5 full slab	R-7.5 for 12" below + R-5 full slab	R-7.5 for 12" below + R-5 full slab	R-7.5 for 12" below + R-5 full slab	R-7.5 for 12" below + R-5 full slab	R-7.5 for 12" below + R-5 full slab	R-7.5 for 12" below + R-5 full slab
Opaque doors																
Nonswinging	R-4.75	R-4.75	R-4.75	R-4.75	R-4.75	R-4.75	R-4.75	R-4.75	R-4.75	R-4.75	R-4.75	R-4.75	R-4.75	R-4.75	R-4.75	R-4.75

For SI: 1 inch = 25.4 mm, 1 pound per square foot = 4.88 kg/m², 1 pound per cubic foot = 16 kg/m³.
 ci = Continuous insulation, NR = No Requirement, LS = Liner System.
 a. Assembly descriptions can be found in ANSI/ASHRAE/IESNA Appendix A.
 b. Where using R-value compliance method, a thermal spacer block shall be provided, otherwise use the U-factor compliance method in Table C402.1.4.
 c. R-5.7ci is allowed to be substituted with concrete block walls complying with ASTM C90, ungrouted or partially grouted at 32 inches or less on center vertically and 48 inches or less on center horizontally, with ungrouted cores filled with materials having a maximum thermal conductivity of 0.44 Btu-in/h-ft²-°F.
 d. Where heated slabs are below grade, below-grade walls shall comply with the exterior insulation requirements for heated slabs.
 e. "Mass floors" shall be in accordance with Section C402.2.3.
 f. Steel floor joist systems shall be insulated to R-38.
 g. "Mass walls" shall be in accordance with Section C402.2.2.
 h. The first value is for perimeter insulation and the second value is for slab insulation. Perimeter insulation is not required to extend below the bottom of the slab.
 i. Not applicable to garage doors. See Table C402.1.4.

TABLE C402.1.4 OPAQUE THERMAL ENVELOPE ASSEMBLY MAXIMUM REQUIREMENTS, U-FACTOR METHOD^{a, b}

CLIMATE ZONE	1		2		3		4		5		6		7		8	
	All other	Group R	All other	Group R	All other	Group R	All other	Group R	All other	Group R	All other	Group R	All other	Group R	All other	Group R
Roofs																
Insulation entirely above roof deck	U-0.048	U-0.039	U-0.039	U-0.039	U-0.039	U-0.039	U-0.032	U-0.032	U-0.032	U-0.032	U-0.032	U-0.032	U-0.028	U-0.028	U-0.028	U-0.028
Metal buildings	U-0.044	U-0.035	U-0.035	U-0.035	U-0.035	U-0.035	U-0.035	U-0.035	U-0.035	U-0.035	U-0.035	U-0.031	U-0.029	U-0.029	U-0.029	U-0.029
Attic and other	U-0.027	U-0.027	U-0.027	U-0.027	U-0.027	U-0.027	U-0.027	U-0.027	U-0.027	U-0.027	U-0.021	U-0.021	U-0.021	U-0.021	U-0.021	U-0.021
Walls, above grade																
Mass ^g	U-0.151	U-0.151	U-0.123	U-0.104	U-0.104	U-0.104	U-0.090	U-0.090	U-0.080	U-0.080	U-0.071	U-0.071	U-0.071	U-0.071	U-0.061	U-0.061
Metal building	U-0.079	U-0.079	U-0.079	U-0.052	U-0.052	U-0.052	U-0.052	U-0.052	U-0.052	U-0.052	U-0.052	U-0.052	U-0.039	U-0.039	U-0.039	U-0.039
Metal framed	U-0.077	U-0.077	U-0.064	U-0.064	U-0.064	U-0.064	U-0.064	U-0.064	U-0.064	U-0.064	U-0.064	U-0.064	U-0.052	U-0.052	U-0.052	U-0.052
Wood framed and other ^h	U-0.064	U-0.064	U-0.064	U-0.064	U-0.064	U-0.064	U-0.064	U-0.064	U-0.064	U-0.064	U-0.051	U-0.051	U-0.051	U-0.051	U-0.051	U-0.051
Walls, below grade																
Below-grade wall ^c	C-1.140 ^e	C-1.140 ^e	C-1.140 ^e	C-1.140 ^e	C-1.140 ^e	C-1.140 ^e	C-0.119	C-0.119	C-0.119	C-0.119	C-0.119	C-0.119	C-0.092	C-0.092	C-0.092	C-0.092
Floors																
Mass ^d	U-0.322 ^e	U-0.107	U-0.087	U-0.076	U-0.076	U-0.076	U-0.074	U-0.074	U-0.064	U-0.064	U-0.055	U-0.055	U-0.051	U-0.051	U-0.051	U-0.051
Joist/framing	U-0.066 ^e	U-0.033	U-0.033	U-0.033	U-0.033	U-0.033	U-0.033	U-0.033	U-0.033	U-0.033	U-0.033	U-0.033	U-0.033	U-0.033	U-0.033	U-0.033
Slab-on-grade floors																
Unheated slabs	F-0.73 ^e	F-0.73 ^e	F-0.73 ^e	F-0.73 ^e	F-0.73 ^e	F-0.73 ^e	F-0.54	F-0.54	F-0.54	F-0.54	F-0.40	F-0.40	F-0.40	F-0.40	F-0.40	F-0.40
Heated slabs ^f	F-1.02	F-1.02	F-0.90	F-0.90	F-0.90	F-0.90	F-0.86	F-0.86	F-0.79	F-0.79	F-0.69	F-0.69	F-0.69	F-0.69	F-0.69	F-0.69
	0.74	0.74	0.74	0.74	0.74	0.74	0.64	0.64	0.64	0.64	0.55	0.55	0.55	0.55	0.55	0.55
Opaque doors																
Swinging door	U-0.61	U-0.61	U-0.61	U-0.61	U-0.61	U-0.61	U-0.61	U-0.61	U-0.37	U-0.37	U-0.37	U-0.37	U-0.37	U-0.37	U-0.37	U-0.37
Garage door <14% glazing	U-0.31	U-0.31	U-0.31	U-0.31	U-0.31	U-0.31	U-0.31	U-0.31	U-0.31	U-0.31	U-0.31	U-0.31	U-0.31	U-0.31	U-0.31	U-0.31

For SI: 1 pound per square foot = 4.88 kg/m², 1 pound per cubic foot = 16 kg/m³.

c1 = Continuous insulation, NR = No Requirement, LS = Liner System.

a. Where assembly U-factors, C-factors, and F-factors are established in ANSI/ASHRAE/IESNA 90.1 Appendix A, such opaque assemblies shall be a compliance alternative where those values meet the criteria of this table, and provided that the construction, excluding the cladding system on walls, complies with the appropriate construction details from ANSI/ASHRAE/IESNA 90.1 Appendix A.

b. Where U-factors have been established by testing in accordance with ASTM C1363, such opaque assemblies shall be a compliance alternative where those values meet the criteria of this table. The R-value of continuous insulation shall be permitted to be added to or subtracted from the original tested design.

c. Where heated slabs are below grade, below-grade walls shall comply with the U-factor requirements for above-grade mass walls.

d. "Mass floors" shall be in accordance with Section C402.2.3.

e. These C-, F-, and U-factors are based on assemblies that are not required to contain insulation.

f. The first value is for perimeter insulation and the second value is for full slab insulation.

g. "Mass walls" shall be in accordance with Section C402.2.2.

designed in accordance with the *R*-value method of Section C402.1.3 shall be as specified in Table C402.1.3. The perimeter insulation shall be placed on the outside of the foundation or on the inside of the foundation wall. The perimeter insulation shall extend downward from the top of the slab for the minimum distance shown in the table or to the top of the footing, whichever is less, or downward to not less than the bottom of the slab and then horizontally to the interior or exterior for the total distance shown in the table. Insulation extending away from the building shall be protected by pavement or by not less than of 10 inches (254 mm) of soil.

Exception: Where the slab-on-grade floor is greater than 24 inches (61 mm) below the finished exterior grade, perimeter insulation is not required.

C402.2.5 Below-grade walls. The *C*-factor for the below-grade exterior walls shall be in accordance with Table C402.1.4. The *R*-value of the insulating material installed continuously within or on the below-grade exterior walls of the building envelope shall be in accordance with Table C402.1.3. The *C*-factor or *R*-value required shall extend to a depth of not less than 10 feet (3048 mm) below the outside finished ground level, or to the level of the lowest floor of the conditioned space enclosed by the below-grade wall, whichever is less.

C402.2.6 Insulation of radiant heating systems. *Radiant heating system* panels, and their associated components that are installed in interior or exterior assemblies shall be insulated to an *R*-value of not less than R-3.5 on all surfaces not facing the space being heated. *Radiant heating system* panels that are installed in the *building thermal envelope* shall be separated from the exterior of the building or unconditioned or exempt spaces by not less than the *R*-value of insulation installed in the opaque assembly in which they are installed or the assembly shall comply with Section C402.1.4.

Exception: Heated slabs on grade insulated in accordance with Section C402.2.4.

C402.2.7 Airspaces. Where the thermal properties of airspaces are used to comply with this code in accordance with Section C401.2, such airspaces shall be enclosed in an unventilated cavity constructed to minimize airflow into and out of the enclosed airspace. Airflow shall be deemed minimized where the enclosed airspace is located on the interior side of the continuous air barrier and is bounded on all sides by building components.

Exception: The thermal resistance of airspaces located on the exterior side of the continuous air barrier and adjacent to and behind the exterior wall-covering material shall be determined in accordance with ASTM C1363 modified with an airflow entering the bottom and exiting the top of the airspace at an air movement rate of not less than 70 mm/second.

C402.3 Roof solar reflectance and thermal emittance. Low-sloped roofs directly above cooled conditioned spaces

in *Climate Zones* 1, 2 and 3 shall comply with one or more of the options in Table C402.3.

Exceptions: The following roofs and portions of roofs are exempt from the requirements of Table C402.3:

1. Portions of the roof that include or are covered by the following:
 - 1.1. Photovoltaic systems or components.
 - 1.2. Solar air or water-heating systems or components.
 - 1.3. Roof gardens or landscaped roofs.
 - 1.4. Above-roof decks or walkways.
 - 1.5. Skylights.
 - 1.6. HVAC systems and components, and other opaque objects mounted above the roof.
2. Portions of the roof shaded during the peak sun angle on the summer solstice by permanent features of the building or by permanent features of adjacent buildings.
3. Portions of roofs that are ballasted with a minimum stone ballast of 17 pounds per square foot [74 kg/m²] or 23 psf [117 kg/m²] pavers.
4. Roofs where not less than 75 percent of the roof area complies with one or more of the exceptions to this section.

C402.3.1 Aged roof solar reflectance. Where an aged solar reflectance required by Section C402.3 is not available, it shall be determined in accordance with Equation 4-3.

$$R_{aged} = [0.2 + 0.7(R_{initial} - 0.2)] \quad \text{(Equation 4-3)}$$

where:

R_{aged} = The aged solar reflectance.

$R_{initial}$ = The initial solar reflectance determined in accordance with CRRS-S100.

C402.4 Fenestration (Prescriptive). Fenestration shall comply with Sections C402.4.1 through C402.4.5 and Table C402.4. Daylight responsive controls shall comply with this section and Section C405.2.3.1.

C402.4.1 Maximum area. The vertical fenestration area, not including opaque doors and opaque spandrel panels, shall be not greater than 30 percent of the gross above-grade wall area. The skylight area shall be not greater than 3 percent of the gross roof area.

C402.4.1.1 Increased vertical fenestration area with daylight responsive controls. In *Climate Zones* 1 through 6, not more than 40 percent of the gross above-grade wall area shall be vertical fenestration, provided that all of the following requirements are met:

1. In buildings not greater than two stories above grade, not less than 50 percent of the net floor area is within a *daylight zone*.

**TABLE C402.3
MINIMUM ROOF REFLECTANCE AND EMITTANCE OPTIONS^a**

Three-year-aged solar reflectance index ^b of 55 and 3-year aged thermal emittance ^c of 0.75
Three-year-aged solar reflectance index ^d of 64

- a. The use of area-weighted averages to comply with these requirements shall be permitted. Materials lacking 3-year-aged tested values for either solar reflectance or thermal emittance shall be assigned both a 3-year-aged solar reflectance in accordance with Section C402.3.1 and a 3-year-aged thermal emittance of 0.90.
- b. Aged solar reflectance tested in accordance with ASTM C1549, ASTM E903 or ASTM E1918 or CRRC-S100.
- c. Aged thermal emittance tested in accordance with ASTM C1371 or ASTM E408 or CRRC-S100.
- d. Solar reflectance index (SRI) shall be determined in accordance with ASTM E1980 using a convection coefficient of 2.1 Btu/h • ft² • °F (12W/m² • K). Calculation of aged SRI shall be based on aged tested values of solar reflectance and thermal emittance.

**TABLE C402.4
BUILDING ENVELOPE FENESTRATION MAXIMUM U-FACTOR AND SHGC REQUIREMENTS**

CLIMATE ZONE	1		2		3		4 EXCEPT MARINE		5 AND MARINE 4		6		7		8		
Vertical fenestration																	
U-factor																	
Fixed fenestration	0.50		0.50		0.46		0.38		0.38		0.36		0.29		0.29		
Operable fenestration	0.65		0.65		0.60		0.45		0.45		0.43		0.37		0.37		
Entrance doors	1.10		0.83		0.77		0.77		0.77		0.77		0.77		0.77		
SHGC																	
Orientation ^a	SEW	N	SEW	N	SEW	N	SEW	N	SEW	N	SEW	N	SEW	N	SEW	N	
PF < 0.2	0.25	0.33	0.25	0.33	0.25	0.33	0.36	0.48	0.38	0.51	0.40	0.53	0.45	NR	0.45	N	
0.2 ≤ PF < 0.5	0.30	0.37	0.30	0.37	0.30	0.37	0.43	0.53	0.46	0.56	0.48	0.58	NR	NR	NR	NR	
PF ≥ 0.5	0.40	0.40	0.40	0.40	0.40	0.40	0.58	0.58	0.61	0.61	0.64	0.64	NR	NR	NR	NR	
Skylights																	
U-factor	0.75		0.65		0.55		0.50		0.50		0.50		0.50		0.50		
SHGC	0.35		0.35		0.35		0.40		0.40		0.40		NR		NR		

NR = No Requirement, PF = Projection Factor.

a. "N" indicates vertical fenestration oriented within 45 degrees of true north. "SEW" indicates orientations other than "N." For buildings in the southern hemisphere, reverse south and north. Buildings located at less than 23.5 degrees latitude shall use SEW for all orientations.

- 2. In buildings three or more stories above grade, not less than 25 percent of the net floor area is within a *daylight zone*.
- 3. *Daylight responsive controls* complying with Section C405.2.3.1 are installed in *daylight zones*.
- 4. Visible transmittance (VT) of vertical fenestration is not less than 1.1 times solar heat gain coefficient (SHGC).

Exception: Fenestration that is outside the scope of NFRC 200 is not required to comply with Item 4.

C402.4.1.2 Increased skylight area with daylight responsive controls. The skylight area shall be not more than 6 percent of the roof area provided that *daylight responsive controls* complying with Section C405.2.3.1 are installed in *toplit zones*.

C402.4.2 Minimum skylight fenestration area. In an enclosed space greater than 2,500 square feet (232 m²) in floor area, directly under a roof with not less than 75 percent of the ceiling area with a ceiling height greater than 15 feet (4572 mm), and used as an office, lobby, atrium, concourse, corridor, storage space, gymnasium/exercise center, convention center, automotive service area, space where manufacturing occurs, nonrefrigerated warehouse, retail store, distribution/sorting area, transportation depot or workshop, the total *toplit daylight zone* shall be not less

than half the floor area and shall provide one of the following:

- 1. A minimum skylight area to *toplit daylight zone* of not less than 3 percent where all skylights have a VT of not less than 0.40 as determined in accordance with Section C303.1.3.
- 2. A minimum skylight effective aperture of not less than 1 percent, determined in accordance with Equation 4-4.

$$\text{Skylight Effective Aperture} = \frac{0.85 \times \text{Skylight Area} \times \text{Skylight VT} \times \text{WF}}{\text{Toplit Zone}} \quad \text{(Equation 4-4)}$$

where:

- Skylight area = Total fenestration area of skylights.
- Skylight VT = Area weighted average visible transmittance of skylights.
- WF = Area weighted average well factor, where well factor is 0.9 if light well depth is less than 2 feet (610 mm), or 0.7 if light well depth is 2 feet (610 mm) or greater.

Light well depth = Measure vertically from the underside of the lowest point of the skylight glazing to the ceiling plane under the skylight.

Exception: Skylights above *daylight zones* of enclosed spaces are not required in:

1. Buildings in *Climate Zones* 6 through 8.
2. Spaces where the designed *general lighting* power densities are less than 0.5 W/ft² (5.4 W/m²).
3. Areas where it is documented that existing structures or natural objects block direct beam sunlight on not less than half of the roof over the enclosed area for more than 1,500 daytime hours per year between 8 a.m. and 4 p.m.
4. Spaces where the *daylight zone* under rooftop monitors is greater than 50 percent of the enclosed space floor area.
5. Spaces where the total area minus the area of sidelight *daylight zones* is less than 2,500 square feet (232 m²), and where the lighting is controlled in accordance with Section C405.2.3.

C402.4.2.1 Lighting controls in toplit daylight zones. *Daylight responsive controls* complying with Section C405.2.3.1 shall be provided to control all electric lights within *toplit zones*.

C402.4.2.2 Haze factor. Skylights in office, storage, automotive service, manufacturing, nonrefrigerated warehouse, retail store and distribution/sorting area spaces shall have a glazing material or diffuser with a haze factor greater than 90 percent when tested in accordance with ASTM D1003.

Exception: Skylights designed and installed to exclude direct sunlight entering the occupied space by the use of fixed or automated baffles or the geometry of skylight and light well.

C402.4.3 Maximum U-factor and SHGC. The maximum *U-factor* and solar heat gain coefficient (SHGC) for fenestration shall be as specified in Table C402.4.

The window projection factor shall be determined in accordance with Equation 4-5.

$$PF = A/B \quad \text{(Equation 4-5)}$$

where:

PF = Projection factor (decimal).

A = Distance measured horizontally from the farthest continuous extremity of any overhang, eave or permanently attached shading device to the vertical surface of the glazing.

B = Distance measured vertically from the bottom of the glazing to the underside of the overhang, eave or permanently attached shading device.

Where different windows or glass doors have different *PF* values, they shall each be evaluated separately.

C402.4.3.1 Increased skylight SHGC. In *Climate Zones* 1 through 6, skylights shall be permitted a maximum SHGC of 0.60 where located above *daylight zones* provided with *daylight responsive controls*.

C402.4.3.2 Increased skylight U-factor. Where skylights are installed above *daylight zones* provided with *daylight responsive controls*, a maximum *U-factor* of 0.9 shall be permitted in *Climate Zones* 1 through 3 and a maximum *U-factor* of 0.75 shall be permitted in *Climate Zones* 4 through 8.

C402.4.3.3 Dynamic glazing. Where dynamic glazing is intended to satisfy the SHGC and VT requirements of Table C402.4, the ratio of the higher to lower labeled SHGC shall be greater than or equal to 2.4, and the *dynamic glazing* shall be automatically controlled to modulate the amount of solar gain into the space in multiple steps. Dynamic glazing shall be considered separately from other fenestration, and area-weighted averaging with other fenestration that is not dynamic glazing shall not be permitted.

Exception: Dynamic glazing is not required to comply with this section where both the lower and higher labeled SHGC already comply with the requirements of Table C402.4.

C402.4.3.4 Area-weighted U-factor. An area-weighted average shall be permitted to satisfy the *U-factor* requirements for each fenestration product category listed in Table C402.4. Individual fenestration products from different fenestration product categories listed in Table C402.4 shall not be combined in calculating area-weighted average *U-factor*.

C402.4.4 Daylight zones. Daylight zones referenced in Sections C402.4.1.1 through C402.4.3.2 shall comply with Sections C405.2.3.2 and C405.2.3.3, as applicable. Daylight zones shall include *toplit zones* and sidelit zones.

C402.4.5 Doors. Opaque swinging doors shall comply with Table C402.1.4. Opaque nonswinging doors shall comply with Table C402.1.3. Opaque doors shall be considered as part of the gross area of above-grade walls that are part of the building *thermal envelope*. Other doors shall comply with the provisions of Section C402.4.3 for vertical fenestration.

C402.5 Air leakage—thermal envelope (Mandatory). The *thermal envelope* of buildings shall comply with Sections C402.5.1 through C402.5.8, or the building *thermal envelope* shall be tested in accordance with ASTM E 779 at a pressure differential of 0.3 inch water gauge (75 Pa) or an equivalent method approved by the code official and deemed to comply with the provisions of this section when the tested air leakage rate of the building thermal envelope is not greater than 0.40 cfm/ft² (2.0 L/s • m²). Where compliance is based on such testing, the building shall also comply with Sections C402.5.5, C402.5.6 and C402.5.7.

C402.5.1 Air barriers. A continuous air barrier shall be provided throughout the building thermal envelope. The air barriers shall be permitted to be located on the inside or outside of the building envelope, located within the assemblies composing the envelope, or any combination thereof. The air barrier shall comply with Sections C402.5.1.1 and C402.5.1.2.

Exception: Air barriers are not required in buildings located in *Climate Zone* 2B.

**TABLE C402.5.2
MAXIMUM AIR LEAKAGE RATE
FOR FENESTRATION ASSEMBLIES**

FENESTRATION ASSEMBLY	MAXIMUM RATE (CFM/FT ²)	TEST PROCEDURE
Windows	0.20 ^a	AAMA/WDMA/ CSA101/I.S.2/A440 or NFRC 400
Sliding doors	0.20 ^a	
Swinging doors	0.20 ^a	
Skylights – with condensation weepage openings	0.30	
Skylights – all other	0.20 ^a	
Curtain walls	0.06	NFRC 400 or ASTM E283 at 1.57 psf (75 Pa)
Storefront glazing	0.06	
Commercial glazed swinging entrance doors	1.00	
Power-operated sliding doors and power-operated folding doors	1.00	
Revolving doors	1.00	
Garage doors	0.40	
Rolling doors	1.00	
High-speed doors	1.30	

For SI: 1 cubic foot per minute = 0.47 L/s, 1 square foot = 0.093 m².

a. The maximum rate for windows, sliding and swinging doors, and skylights is permitted to be 0.3 cfm per square foot of fenestration or door area when tested in accordance with AAMA/WDMA/CSA101/I.S.2/A440 at 6.24 psf (300 Pa).

C402.5.3 Rooms containing fuel-burning appliances. In *Climate Zones* 3 through 8, where combustion air is supplied through openings in an exterior wall to a room or space containing a space-conditioning fuel-burning appliance, one of the following shall apply:

1. The room or space containing the appliance shall be located outside of the *building thermal envelope*.
2. The room or space containing the appliance shall be enclosed and isolated from conditioned spaces inside the building thermal envelope. Such rooms shall comply with all of the following:
 - 2.1. The walls, floors and ceilings that separate the enclosed room or space from conditioned spaces shall be insulated to be not less than equivalent to the insulation requirement of below-grade walls as specified in Table C402.1.3 or C402.1.4.
 - 2.2. The walls, floors and ceilings that separate the enclosed room or space from conditioned spaces shall be sealed in accordance with Section C402.5.1.1.
 - 2.3. The doors into the enclosed room or space shall be fully gasketed.
 - 2.4. Water lines and ducts in the enclosed room or space shall be insulated in accordance with Section C403.
 - 2.5. Where an air duct supplying combustion air to the enclosed room or space passes through

conditioned space, the duct shall be insulated to an *R*-value of not less than R-8.

Exception: Fireplaces and stoves complying with Sections 901 through 905 of the *International Mechanical Code*, and Section 2111.14 of the *International Building Code*.

C402.5.4 Doors and access openings to shafts, chutes, stairways and elevator lobbies. Doors and access openings from conditioned space to shafts, chutes stairways and elevator lobbies not within the scope of the fenestration assemblies covered by Section C402.5.2 shall be gasketed, weatherstripped or sealed.

Exceptions:

1. Door openings required to comply with Section 716 of the *International Building Code*.
2. Doors and door openings required to comply with UL 1784 by the *International Building Code*.

C402.5.5 Air intakes, exhaust openings, stairways and shafts. Stairway enclosures, elevator shaft vents and other outdoor air intakes and exhaust openings integral to the building envelope shall be provided with dampers in accordance with Section C403.7.7.

C402.5.6 Loading dock weatherseals. Cargo door openings and loading door openings shall be equipped with weatherseals that restrict infiltration and provide direct contact along the top and sides of vehicles that are parked in the doorway.

C402.5.7 Vestibules. Building entrances shall be protected with an enclosed vestibule, with all doors opening into and out of the vestibule equipped with self-closing devices. Vestibules shall be designed so that in passing through the vestibule it is not necessary for the interior and exterior doors to open at the same time. The installation of one or more revolving doors in the building entrance shall not eliminate the requirement that a vestibule be provided on any doors adjacent to revolving doors.

Exceptions: Vestibules are not required for the following:

1. Buildings in *Climate Zones* 1 and 2.
2. Doors not intended to be used by the public, such as doors to mechanical or electrical equipment rooms, or intended solely for employee use.
3. Doors opening directly from a *sleeping unit* or dwelling unit.
4. Doors that open directly from a space less than 3,000 square feet (298 m²) in area.
5. Revolving doors.
6. Doors used primarily to facilitate vehicular movement or material handling and adjacent personnel doors.
7. Doors that have an air curtain with a velocity of not less than 6.56 feet per second (2 m/s) at the floor that have been tested in accordance with ANSI/AMCA 220 and installed in accordance with the manufacturer’s instructions. Manual or

automatic controls shall be provided that will operate the air curtain with the opening and closing of the door. Air curtains and their controls shall comply with Section C408.2.3.

C402.5.8 Recessed lighting. Recessed luminaires installed in the *building thermal envelope* shall be all of the following:

1. IC-rated.
2. Labeled as having an air leakage rate of not more 2.0 cfm (0.944 L/s) when tested in accordance with ASTM E283 at a 1.57 psf (75 Pa) pressure differential.
3. Sealed with a gasket or caulk between the housing and interior wall or ceiling covering.

SECTION C403 BUILDING MECHANICAL SYSTEMS

C403.1 General. Mechanical systems and equipment serving the building heating, cooling, ventilating or refrigerating needs shall comply with this section.

C403.1.1 Calculation of heating and cooling loads. Design loads associated with heating, ventilating and air conditioning of the building shall be determined in accordance with ANSI/ASHRAE/ACCA Standard 183 or by an *approved* equivalent computational procedure using the design parameters specified in Chapter 3. Heating and cooling loads shall be adjusted to account for load reductions that are achieved where energy recovery systems are utilized in the HVAC system in accordance with the *ASHRAE HVAC Systems and Equipment Handbook* by an approved equivalent computational procedure.

C403.2 System design (Mandatory). Mechanical systems shall be designed to comply with Sections C403.2.1 and C403.2.2. Where elements of a building's mechanical systems are addressed in Sections C403.3 through C403.12, such elements shall comply with the applicable provisions of those sections.

C403.2.1 Zone isolation required (Mandatory). HVAC systems serving *zones* that are over 25,000 square feet (2323 m²) in floor area or that span more than one floor and are designed to operate or be occupied nonsimultaneously shall be divided into isolation areas. Each isolation area shall be equipped with *isolation devices* and controls configured to automatically shut off the supply of conditioned air and outdoor air to and exhaust air from the isolation area. Each isolation area shall be controlled independently by a device meeting the requirements of Section C403.4.2.2. Central systems and plants shall be provided with controls and devices that will allow system and equipment operation for any length of time while serving only the smallest isolation area served by the system or plant.

Exceptions:

1. Exhaust air and outdoor air connections to isolation areas where the fan system to which they connect is not greater than 5,000 cfm (2360 L/s).

2. Exhaust airflow from a single isolation area of less than 10 percent of the design airflow of the exhaust system to which it connects.
3. Isolation areas intended to operate continuously or intended to be inoperative only when all other isolation areas in a *zone* are inoperative.

C403.2.2 Ventilation (Mandatory). Ventilation, either natural or mechanical, shall be provided in accordance with Chapter 4 of the *International Mechanical Code*. Where mechanical ventilation is provided, the system shall provide the capability to reduce the outdoor air supply to the minimum required by Chapter 4 of the *International Mechanical Code*.

C403.3 Heating and cooling equipment efficiencies (Mandatory). Heating and cooling equipment installed in mechanical systems shall be sized in accordance with Section C403.3.1 and shall be not less efficient in the use of energy than as specified in Section C403.3.2.

C403.3.1 Equipment sizing (Mandatory). The output capacity of heating and cooling equipment shall be not greater than that of the smallest available equipment size that exceeds the loads calculated in accordance with Section C403.1.1. A single piece of equipment providing both heating and cooling shall satisfy this provision for one function with the capacity for the other function as small as possible, within available equipment options.

Exceptions:

1. Required standby equipment and systems provided with controls and devices that allow such systems or equipment to operate automatically only when the primary equipment is not operating.
2. Multiple units of the same equipment type with combined capacities exceeding the design load and provided with controls that are configured to sequence the operation of each unit based on load.

C403.3.2 HVAC equipment performance requirements (Mandatory). Equipment shall meet the minimum efficiency requirements of Tables C403.3.2(1) through C403.3.2(9) when tested and rated in accordance with the applicable test procedure. Plate-type liquid-to-liquid heat exchangers shall meet the minimum requirements of Table C403.3.2(10). The efficiency shall be verified through certification under an approved certification program or, where a certification program does not exist, the equipment efficiency ratings shall be supported by data furnished by the manufacturer. Where multiple rating conditions or performance requirements are provided, the equipment shall satisfy all stated requirements. Where components, such as indoor or outdoor coils, from different manufacturers are used, calculations and supporting data shall be furnished by the designer that demonstrates that the combined efficiency of the specified components meets the requirements herein.

C403.3.2.1 Water-cooled centrifugal chilling packages (Mandatory). Equipment not designed for operation at AHRI Standard 550/590 test conditions of 44°F

(7°C) leaving chilled-water temperature and 2.4 gpm/ton evaporator fluid flow and 85°F (29°C) entering condenser water temperature with 3 gpm/ton (0.054 l/s • kW) condenser water flow shall have maximum full-load kW/ton (FL) and part-load ratings requirements adjusted using Equations 4-6 and 4-7.

$$FL_{adj} = FL/K_{adj} \quad \text{(Equation 4-6)}$$

$$PLV_{adj} = IPLV/K_{adj} \quad \text{(Equation 4-7)}$$

where:

$$K_{adj} = A \times B$$

FL = Full-load kW/ton value as specified in Table C403.3.2(7).

FL_{adj} = Maximum full-load kW/ton rating, adjusted for nonstandard conditions.

$IPLV$ = Value as specified in Table C403.3.2(7).

PLV_{adj} = Maximum $NPLV$ rating, adjusted for nonstandard conditions.

$$A = 0.00000014592 \times (LIFT)^4 + 0.0000346496 \times (LIFT)^3 + 0.00314196 \times (LIFT)^2 - 0.147199 \times (LIFT) + 3.9302$$

$$B = 0.0015 \times L_{vg}E_{vap} + 0.934$$

$$LIFT = L_{vg}Cond - L_{vg}E_{vap}$$

$L_{vg}Cond$ = Full-load condenser leaving fluid temperature (°F).

$L_{vg}E_{vap}$ = Full-load evaporator leaving temperature (°F).

The FL_{adj} and PLV_{adj} values are only applicable for centrifugal chillers meeting all of the following full-load design ranges:

1. Minimum evaporator leaving temperature: 36°F.
2. Maximum condenser leaving temperature: 115°F.
3. 20°F ≤ LIFT ≤ 80°F.

C403.3.2.2 Positive displacement (air- and water-cooled) chilling packages. Equipment with a leaving fluid temperature higher than 32°F (0°C) and water-cooled positive displacement chilling packages with a condenser leaving fluid temperature below 115°F (46°C) shall meet the requirements of Table C403.3.2(7) when tested or certified with water at standard rating conditions, in accordance with the referenced test procedure.

C403.3.3 Hot gas bypass limitation. Cooling systems shall not use hot gas bypass or other evaporator pressure control systems unless the system is designed with multiple steps of unloading or continuous capacity modulation. The capacity of the hot gas bypass shall be limited as indicated in Table C403.3.3, as limited by Section C403.5.1.

**TABLE C403.3.3
MAXIMUM HOT GAS BYPASS CAPACITY**

RATED CAPACITY	MAXIMUM HOT GAS BYPASS CAPACITY (% of total capacity)
≤ 240,000 Btu/h	50
> 240,000 Btu/h	25

For SI: 1 British thermal unit per hour = 0.2931 W.

C403.3.4 Boiler turndown. Boiler systems with design input of greater than 1,000,000 Btu/h (293 kW) shall comply with the turndown ratio specified in Table C403.3.4.

The system turndown requirement shall be met through the use of multiple single-input boilers, one or more *modulating boilers* or a combination of single-input and *modulating boilers*.

**TABLE C403.3.4
BOILER TURNDOWN**

BOILER SYSTEM DESIGN INPUT (Btu/h)	MINIMUM TURNDOWN RATIO
≥ 1,000,000 and less than or equal to 5,000,000	3 to 1
> 5,000,000 and less than or equal to 10,000,000	4 to 1
> 10,000,000	5 to 1

For SI: 1 British thermal unit per hour = 0.2931 W.

C403.4 Heating and cooling system controls (Mandatory). Each heating and cooling system shall be provided with controls in accordance with Sections C403.4.1 through C403.4.5.

C403.4.1 Thermostatic controls (Mandatory). The supply of heating and cooling energy to each *zone* shall be controlled by individual thermostatic controls capable of responding to temperature within the *zone*. Where humidification or dehumidification or both is provided, not fewer than one humidity control device shall be provided for each humidity control system.

Exception: Independent perimeter systems that are designed to offset only building envelope heat losses, gains or both serving one or more perimeter *zones* also served by an interior system provided that both of the following conditions are met:

1. The perimeter system includes not fewer than one thermostatic control *zone* for each building exposure having exterior walls facing only one orientation (within ± 45 degrees) (0.8 rad) for more than 50 contiguous feet (15 240 mm).
2. The perimeter system heating and cooling supply is controlled by thermostats located within the *zones* served by the system.

C403.4.1.1 Heat pump supplementary heat (Mandatory). Heat pumps having supplementary electric resistance heat shall have controls that, except during defrost, prevent supplementary heat operation where the heat pump can provide the heating load.

TABLE C403.3.2(1)
MINIMUM EFFICIENCY REQUIREMENTS:
ELECTRICALLY OPERATED UNITARY AIR CONDITIONERS AND CONDENSING UNITS

EQUIPMENT TYPE	SIZE CATEGORY	HEATING SECTION TYPE	SUBCATEGORY OR RATING CONDITION	MINIMUM EFFICIENCY	TEST PROCEDURE ^a		
Air conditioners, air cooled	< 65,000 Btu/h ^b	All	Split System	13.0 SEER	AHRI 210/240		
			Single Package	14.0 SEER			
Through-the-wall (air cooled)	≤ 30,000 Btu/h ^b	All	Split system	12.0 SEER			
			Single Package	12.0 SEER			
Small-duct high-velocity (air cooled)	< 65,000 Btu/h ^b	All	Split System	11.0 SEER			
Air conditioners, air cooled	≥ 65,000 Btu/h and < 135,000 Btu/h	Electric Resistance (or None)	Split System and Single Package	11.2 EER 12.8 IEER		AHRI 340/360	
		All other	Split System and Single Package	11.0 EER 12.6 IEER			
	≥ 135,000 Btu/h and < 240,000 Btu/h	Electric Resistance (or None)	Split System and Single Package	11.0 EER 12.4 IEER			
		All other	Split System and Single Package	10.8 EER 12.2 IEER			
	≥ 240,000 Btu/h and < 760,000 Btu/h	Electric Resistance (or None)	Split System and Single Package	10.0 EER 11.6 IEER			
		All other	Split System and Single Package	9.8 EER 11.4 IEER			
	≥ 760,000 Btu/h	Electric Resistance (or None)	Split System and Single Package	9.7 EER 11.2 IEER			
		All other	Split System and Single Package	9.5 EER 11.0 IEER			
	Air conditioners, water cooled	< 65,000 Btu/h ^b	All	Split System and Single Package	12.1 EER 12.3 IEER		AHRI 210/240
		≥ 65,000 Btu/h and < 135,000 Btu/h	Electric Resistance (or None)	Split System and Single Package	12.1 EER 13.9 IEER		AHRI 340/360
All other			Split System and Single Package	11.9 EER 13.7 IEER			
≥ 135,000 Btu/h and < 240,000 Btu/h		Electric Resistance (or None)	Split System and Single Package	12.5 EER 13.9 IEER			
		All other	Split System and Single Package	12.3 EER 13.7 IEER			
≥ 240,000 Btu/h and < 760,000 Btu/h		Electric Resistance (or None)	Split System and Single Package	12.4 EER 13.6 IEER			
		All other	Split System and Single Package	12.2 EER 13.4 IEER			
≥ 760,000 Btu/h		Electric Resistance (or None)	Split System and Single Package	12.2 EER 13.5 IEER			
		All other	Split System and Single Package	12.0 EER 13.3 IEER			

(continued)

TABLE C403.3.2(1)—continued
MINIMUM EFFICIENCY REQUIREMENTS:
ELECTRICALLY OPERATED UNITARY AIR CONDITIONERS AND CONDENSING UNITS

EQUIPMENT TYPE	SIZE CATEGORY	HEATING SECTION TYPE	SUB-CATEGORY OR RATING CONDITION	MINIMUM EFFICIENCY	TEST PROCEDURE ^a	
Air conditioners, evaporatively cooled	< 65,000 Btu/h ^b	All	Split System and Single Package	12.1 EER 12.3 IEER	AHRI 210/240	
	≥ 65,000 Btu/h and < 135,000 Btu/h	Electric Resistance (or None)	Split System and Single Package	12.1 EER 12.3 IEER	AHRI 340/360	
		All other	Split System and Single Package	11.9 EER 12.1 IEER		
	≥ 135,000 Btu/h and < 240,000 Btu/h	Electric Resistance (or None)	Split System and Single Package	12.0 EER 12.2 IEER		
		All other	Split System and Single Package	11.8 EER 12.0 IEER		
	≥ 240,000 Btu/h and < 760,000 Btu/h	Electric Resistance (or None)	Split System and Single Package	11.9 EER 12.1 IEER		
		All other	Split System and Single Package	11.7 EER 11.9 IEER		
	≥ 760,000 Btu/h	Electric Resistance (or None)	Split System and Single Package	11.7 EER 11.9 IEER		
		All other	Split System and Single Package	11.5 EER 11.7 IEER		
	Condensing units, air cooled	≥ 135,000 Btu/h	—	—		10.5 EER 11.8 IEER
Condensing units, water cooled	≥ 135,000 Btu/h	—	—	13.5 EER 14.0 IEER		
Condensing units, evaporatively cooled	≥ 135,000 Btu/h	—	—	13.5 EER 14.0 IEER		

For SI: 1 British thermal unit per hour = 0.2931 W.

- a. Chapter 6 contains a complete specification of the referenced test procedure, including the reference year version of the test procedure.
- b. Single-phase, air-cooled air conditioners less than 65,000 Btu/h are regulated by NAECA. SEER values are those set by NAECA.

TABLE C403.3.2(2)
MINIMUM EFFICIENCY REQUIREMENTS:
ELECTRICALLY OPERATED UNITARY AND APPLIED HEAT PUMPS

EQUIPMENT TYPE	SIZE CATEGORY	HEATING SECTION TYPE	SUBCATEGORY OR RATING CONDITION	MINIMUM EFFICIENCY	TEST PROCEDURE ^a
Air cooled (cooling mode)	< 65,000 Btu/h ^b	All	Split System	14.0 SEER	AHRI 210/240
			Single Package	14.0 SEER	
Through-the-wall, air cooled	≤ 30,000 Btu/h ^b	All	Split System	12.0 SEER	
			Single Package	12.0 SEER	
Single-duct high-velocity air cooled	< 65,000 Btu/h ^b	All	Split System	11.0 SEER	
Air cooled (cooling mode)	≥ 65,000 Btu/h and < 135,000 Btu/h	Electric Resistance (or None)	Split System and Single Package	11.0 EER 12.0 IEER	
		All other	Split System and Single Package	10.8 EER 11.8 IEER	
	≥ 135,000 Btu/h and < 240,000 Btu/h	Electric Resistance (or None)	Split System and Single Package	10.6 EER 11.6 IEER	
		All other	Split System and Single Package	10.4 EER 11.4 IEER	
	≥ 240,000 Btu/h	Electric Resistance (or None)	Split System and Single Package	9.5 EER 10.6 IEER	
		All other	Split System and Single Package	9.3 EER 9.4 IEER	
Water to Air: Water Loop (cooling mode)	< 17,000 Btu/h	All	86°F entering water	12.2 EER	ISO 13256-1
	≥ 17,000 Btu/h and < 65,000 Btu/h	All	86°F entering water	13.0 EER	
	≥ 65,000 Btu/h and < 135,000 Btu/h	All	86°F entering water	13.0 EER	
Water to Air: Ground Water (cooling mode)	< 135,000 Btu/h	All	59°F entering water	18.0 EER	ISO 13256-1
Brine to Air: Ground Loop (cooling mode)	< 135,000 Btu/h	All	77°F entering water	14.1 EER	ISO 13256-1
Water to Water: Water Loop (cooling mode)	< 135,000 Btu/h	All	86°F entering water	10.6 EER	ISO 13256-2
Water to Water: Ground Water (cooling mode)	< 135,000 Btu/h	All	59°F entering water	16.3 EER	
Brine to Water: Ground Loop (cooling mode)	< 135,000 Btu/h	All	77°F entering fluid	12.1 EER	

(continued)

**TABLE C403.3.2(2)—continued
MINIMUM EFFICIENCY REQUIREMENTS:
ELECTRICALLY OPERATED UNITARY AND APPLIED HEAT PUMPS**

EQUIPMENT TYPE	SIZE CATEGORY	HEATING SECTION TYPE	SUBCATEGORY OR RATING CONDITION	MINIMUM EFFICIENCY	TEST PROCEDURE ^a
Air cooled (heating mode)	< 65,000 Btu/h ^b	—	Split System	8.2 HSPF	AHRI 210/240
		—	Single Package	8.0 HSPF	
Through-the-wall, (air cooled, heating mode)	≤ 30,000 Btu/h ^b (cooling capacity)	—	Split System	7.4 HSPF	
		—	Single Package	7.4 HSPF	
Small-duct high velocity (air cooled, heating mode)	< 65,000 Btu/h ^b	—	Split System	6.8 HSPF	
Air cooled (heating mode)	≥ 65,000 Btu/h and < 135,000 Btu/h (cooling capacity)	—	47°F db/43°F wb outdoor air	3.3 COP	
			17°F db/15°F wb outdoor air	2.25 COP	
	≥ 135,000 Btu/h (cooling capacity)	—	47°F db/43°F wb outdoor air	3.2 COP	
			17°F db/15°F wb outdoor air	2.05 COP	
Water to Air: Water Loop (heating mode)	< 135,000 Btu/h (cooling capacity)	—	68°F entering water	4.3 COP	ISO 13256-1
Water to Air: Ground Water (heating mode)	< 135,000 Btu/h (cooling capacity)	—	50°F entering water	3.7 COP	
Brine to Air: Ground Loop (heating mode)	< 135,000 Btu/h (cooling capacity)	—	32°F entering fluid	3.2 COP	
Water to Water: Water Loop (heating mode)	< 135,000 Btu/h (cooling capacity)	—	68°F entering water	3.7 COP	ISO 13256-2
Water to Water: Ground Water (heating mode)	< 135,000 Btu/h (cooling capacity)	—	50°F entering water	3.1 COP	
Brine to Water: Ground Loop (heating mode)	< 135,000 Btu/h (cooling capacity)	—	32°F entering fluid	2.5 COP	

For SI: 1 British thermal unit per hour = 0.2931 W, °C = [(°F) - 32]/1.8.

- a. Chapter 6 contains a complete specification of the referenced test procedure, including the reference year version of the test procedure.
- b. Single-phase, air-cooled heat pumps less than 65,000 Btu/h are regulated by NAECA. SEER and HSPF values are those set by NAECA.



TABLE C403.3.2(3)
MINIMUM EFFICIENCY REQUIREMENTS:
ELECTRICALLY OPERATED PACKAGED TERMINAL AIR CONDITIONERS,
PACKAGED TERMINAL HEAT PUMPS, SINGLE-PACKAGE VERTICAL AIR CONDITIONERS,
SINGLE VERTICAL HEAT PUMPS, ROOM AIR CONDITIONERS AND ROOM AIR-CONDITIONER HEAT PUMPS

EQUIPMENT TYPE	SIZE CATEGORY (INPUT)	SUBCATEGORY OR RATING CONDITION	MINIMUM EFFICIENCY	TEST PROCEDURE ^a
PTAC (cooling mode) new construction	All Capacities	95°F db outdoor air	14.0 – (0.300 × Cap/1000) EER	AHRI 310/380
PTAC (cooling mode) replacements ^b	All Capacities	95°F db outdoor air	10.9 - (0.213 × Cap/1000) EER	
PTHP (cooling mode) new construction	All Capacities	95°F db outdoor air	14.0 - (0.300 × Cap/1000) EER	
PTHP (cooling mode) replacements ^b	All Capacities	95°F db outdoor air	10.8 - (0.213 × Cap/1000) EER	
PTHP (heating mode) new construction	All Capacities	—	3.2 - (0.026 × Cap/1000) COP	
PTHP (heating mode) replacements ^b	All Capacities	—	2.9 - (0.026 × Cap/1000) COP	
SPVAC (cooling mode)	< 65,000 Btu/h	95°F db/ 75°F wb outdoor air	9.0 EER	AHRI 390
	≥ 65,000 Btu/h and < 135,000 Btu/h	95°F db/ 75°F wb outdoor air	8.9 EER	
	≥ 135,000 Btu/h and < 240,000 Btu/h	95°F db/ 75°F wb outdoor air	8.6 EER	
SPVHP (cooling mode)	< 65,000 Btu/h	95°F db/ 75°F wb outdoor air	9.0 EER	
	≥ 65,000 Btu/h and < 135,000 Btu/h	95°F db/ 75°F wb outdoor air	8.9 EER	
	≥ 135,000 Btu/h and < 240,000 Btu/h	95°F db/ 75°F wb outdoor air	8.6 EER	
SPVHP (heating mode)	< 65,000 Btu/h	47°F db/ 43°F wb outdoor air	3.0 COP	AHRI 390
	≥ 65,000 Btu/h and < 135,000 Btu/h	47°F db/ 43°F wb outdoor air	3.0 COP	
	≥ 135,000 Btu/h and < 240,000 Btu/h	47°F db/ 75°F wb outdoor air	2.9 COP	
Room air conditioners, with louvered sides	< 6,000 Btu/h	—	11.0 CEER	ANSI/AHAM RAC-1
	≥ 6,000 Btu/h and < 8,000 Btu/h	—	11.0 CEER	
	≥ 8,000 Btu/h and < 14,000 Btu/h	—	10.9 CEER	
	≥ 14,000 Btu/h and < 20,000 Btu/h	—	10.7 CEER	
	≥ 20,000 Btu/h and ≤ 25,000 Btu/h	—	9.4 CEER	
	> 25,000 Btu/h	—	9.0 CEER	
Room air conditioners, without louvered sides	< 6,000 Btu/h	—	10.0 CEER	
	≥ 6,000 Btu/h and < 8,000 Btu/h	—	10.0 CEER	
	≥ 8,000 Btu/h and < 11,000 Btu/h	—	9.6 CEER	
	≥ 11,000 Btu/h and < 14,000 Btu/h	—	9.5 CEER	
	≥ 14,000 Btu/h and < 20,000 Btu/h	—	9.3 CEER	
	≥ 20,000 Btu/h	—	9.4 CEER	
Room air-conditioner heat pumps with louvered sides	< 20,000 Btu/h	—	9.8 CEER	
	≥ 20,000 Btu/h	—	9.3 CEER	
Room air-conditioner heat pumps without louvered sides	< 14,000 Btu/h	—	9.3 CEER	
	≥ 14,000 Btu/h	—	8.7 CEER	

(continued)

TABLE C403.3.2(3)—continued
MINIMUM EFFICIENCY REQUIREMENTS:
ELECTRICALLY OPERATED PACKAGED TERMINAL AIR CONDITIONERS,
PACKAGED TERMINAL HEAT PUMPS, SINGLE-PACKAGE VERTICAL AIR CONDITIONERS,
SINGLE VERTICAL HEAT PUMPS, ROOM AIR CONDITIONERS AND ROOM AIR-CONDITIONER HEAT PUMPS

EQUIPMENT TYPE	SIZE CATEGORY (INPUT)	SUBCATEGORY OR RATING CONDITION	MINIMUM EFFICIENCY	TEST PROCEDURE ^a
Room air conditioner casement only	All capacities	—	9.5 CEER	ANSI/ AHAM RAC-1
Room air conditioner casement-slider	All capacities	—	10.4 CEER	

For SI: 1 British thermal unit per hour = 0.2931 W, °C = [(°F) - 32]/1.8, wb = wet bulb, db = dry bulb.

“Cap” = The rated cooling capacity of the project in Btu/h. Where the unit’s capacity is less than 7000 Btu/h, use 7000 Btu/h in the calculation. Where the unit’s capacity is greater than 15,000 Btu/h, use 15,000 Btu/h in the calculations.

- a. Chapter 6 contains a complete specification of the referenced test procedure, including the referenced year version of the test procedure.
- b. Replacement unit shall be factory labeled as follows: “MANUFACTURED FOR REPLACEMENT APPLICATIONS ONLY: NOT TO BE INSTALLED IN NEW CONSTRUCTION PROJECTS.” Replacement efficiencies apply only to units with existing sleeves less than 16 inches (406 mm) in height and less than 42 inches (1067 mm) in width.

TABLE C403.3.2(4)
WARM-AIR FURNACES AND COMBINATION WARM-AIR FURNACES/AIR-CONDITIONING UNITS,
WARM-AIR DUCT FURNACES AND UNIT HEATERS, MINIMUM EFFICIENCY REQUIREMENTS

EQUIPMENT TYPE	SIZE CATEGORY (INPUT)	SUBCATEGORY OR RATING CONDITION	MINIMUM EFFICIENCY ^{d, e}	TEST PROCEDURE ^a
Warm-air furnaces, gas fired	< 225,000 Btu/h	—	80% AFUE or 80% E_t^c	DOE 10 CFR Part 430 or ANSI Z21.47
	≥ 225,000 Btu/h	Maximum capacity ^c	80% E_t^f	ANSI Z21.47
Warm-air furnaces, oil fired	< 225,000 Btu/h	—	83% AFUE or 80% E_t^c	DOE 10 CFR Part 430 or UL 727
	≥ 225,000 Btu/h	Maximum capacity ^b	81% E_t^g	UL 727
Warm-air duct furnaces, gas fired	All capacities	Maximum capacity ^b	80% E_c	ANSI Z83.8
Warm-air unit heaters, gas fired	All capacities	Maximum capacity ^b	80% E_c	ANSI Z83.8
Warm-air unit heaters, oil fired	All capacities	Maximum capacity ^b	80% E_c	UL 731

For SI: 1 British thermal unit per hour = 0.2931 W.

- a. Chapter 6 contains a complete specification of the referenced test procedure, including the referenced year version of the test procedure.
- b. Minimum and maximum ratings as provided for and allowed by the unit’s controls.
- c. Combination units not covered by the National Appliance Energy Conservation Act of 1987 (NAECA) (3-phase power or cooling capacity greater than or equal to 65,000 Btu/h [19 kW]) shall comply with either rating.
- d. E_t = Thermal efficiency. See test procedure for detailed discussion.
- e. E_c = Combustion efficiency (100% less flue losses). See test procedure for detailed discussion.
- f. E_c = Combustion efficiency. Units shall also include an IID, have jackets not exceeding 0.75 percent of the input rating, and have either power venting or a flue damper. A vent damper is an acceptable alternative to a flue damper for those furnaces where combustion air is drawn from the conditioned space.
- g. E_t = Thermal efficiency. Units shall also include an IID, have jacket losses not exceeding 0.75 percent of the input rating, and have either power venting or a flue damper. A vent damper is an acceptable alternative to a flue damper for those furnaces where combustion air is drawn from the conditioned space.

TABLE C403.3.2(5)
MINIMUM EFFICIENCY REQUIREMENTS: GAS- AND OIL-FIRED BOILERS

EQUIPMENT TYPE ^a	SUBCATEGORY OR RATING CONDITION	SIZE CATEGORY (INPUT)	MINIMUM EFFICIENCY ^{d, e}	TEST PROCEDURE
Boilers, hot water	Gas-fired	< 300,000 Btu/h ^{f, g}	82% AFUE	10 CFR Part 430
		≥ 300,000 Btu/h and ≤ 2,500,000 Btu/h ^b	80% E_t	10 CFR Part 431
		> 2,500,000 Btu/h ^a	82% E_c	
	Oil-fired ^c	< 300,000 Btu/h ^g	84% AFUE	10 CFR Part 430
		≥ 300,000 Btu/h and ≤ 2,500,000 Btu/h ^b	82% E_t	10 CFR Part 431
		> 2,500,000 Btu/h ^a	84% E_c	
Boilers, steam	Gas-fired	< 300,000 Btu/h ^f	80% AFUE	10 CFR Part 430
	Gas-fired- all, except natural draft	≥ 300,000 Btu/h and ≤ 2,500,000 Btu/h ^b	79% E_t	10 CFR Part 431
		> 2,500,000 Btu/h ^a	79% E_t	
	Gas-fired-natural draft	≥ 300,000 Btu/h and ≤ 2,500,000 Btu/h ^b	77% E_t	
		> 2,500,000 Btu/h ^a	77% E_t	
	Oil-fired ^c	< 300,000 Btu/h	82% AFUE	10 CFR Part 430
		≥ 300,000 Btu/h and ≤ 2,500,000 Btu/h ^b	81% E_t	10 CFR Part 431
		> 2,500,000 Btu/h ^a	81% E_t	

For SI: 1 British thermal unit per hour = 0.2931 W.

- a. These requirements apply to boilers with rated input of 8,000,000 Btu/h or less that are not packaged boilers and to all packaged boilers. Minimum efficiency requirements for boilers cover all capacities of packaged boilers.
- b. Maximum capacity – minimum and maximum ratings as provided for and allowed by the unit’s controls.
- c. Includes oil-fired (residual).
- d. E_c = Combustion efficiency (100 percent less flue losses).
- e. E_t = Thermal efficiency. See referenced standard for detailed information.
- f. Boilers shall not be equipped with a constant-burning ignition pilot.
- g. A boiler not equipped with a tankless domestic water heating coil shall be equipped with an automatic means for adjusting the temperature of the water such that an incremental change in inferred heat load produces a corresponding incremental change in the temperature of the water supplied.

TABLE C403.3.2(6)
MINIMUM EFFICIENCY REQUIREMENTS:
CONDENSING UNITS, ELECTRICALLY OPERATED

EQUIPMENT TYPE	SIZE CATEGORY	MINIMUM EFFICIENCY ^b	TEST PROCEDURE ^a
Condensing units, air cooled	≥ 135,000 Btu/h	10.1 EER 11.2 IPLV	AHRI 365
Condensing units, water or evaporatively cooled	≥ 135,000 Btu/h	13.1 EER 13.1 IPLV	

For SI: 1 British thermal unit per hour = 0.2931 W.

- a. Chapter 6 contains a complete specification of the referenced test procedure, including the referenced year version of the test procedure.
- b. IPLVs are only applicable to equipment with capacity modulation.

**TABLE C403.3.2(7)
WATER CHILLING PACKAGES – EFFICIENCY REQUIREMENTS^{a, b, d}**

EQUIPMENT TYPE	SIZE CATEGORY	UNITS	BEFORE 1/1/2015		AS OF 1/1/2015		TEST PROCEDURE ^c
			Path A	Path B	Path A	Path B	
Air-cooled chillers	< 150 Tons	EER (Btu/W)	≥ 9.562 FL	NA ^c	≥ 10.100 FL	≥ 9.700 FL	AHRI 550/590
			≥ 12.500 IPLV		≥ 13.700 IPLV	≥ 15,800 IPLV	
	≥ 150 Tons		≥ 9.562 FL	NA ^c	≥ 10.100 FL	≥ 9.700 FL	
			≥ 12.500 IPLV		≥ 14.000 IPLV	≥ 16.100 IPLV	
Air cooled without condenser, electrically operated	All capacities	EER (Btu/W)	Air-cooled chillers without condenser shall be rated with matching condensers and complying with air-cooled chiller efficiency requirements.				
Water cooled, electrically operated positive displacement	< 75 Tons	kW/ton	≤ 0.780 FL	≤ 0.800 FL	≤ 0.750 FL	≤ 0.780 FL	
	≥ 75 tons and < 150 tons		≤ 0.630 IPLV	≤ 0.600 IPLV	≤ 0.600 IPLV	≤ 0.500 IPLV	
			≤ 0.775 FL	≤ 0.790 FL	≤ 0.720 FL	≤ 0.750 FL	
	≥ 150 tons and < 300 tons		≤ 0.615 IPLV	≤ 0.586 IPLV	≤ 0.560 IPLV	≤ 0.490 IPLV	
			≤ 0.680 FL	≤ 0.718 FL	≤ 0.660 FL	≤ 0.680 FL	
	≥ 300 tons and < 600 tons		≤ 0.580 IPLV	≤ 0.540 IPLV	≤ 0.540 IPLV	≤ 0.440 IPLV	
			≤ 0.620 FL	≤ 0.639 FL	≤ 0.610 FL	≤ 0.625 FL	
	≥ 600 tons		≤ 0.540 IPLV	≤ 0.490 IPLV	≤ 0.520 IPLV	≤ 0.410 IPLV	
≤ 0.620 FL		≤ 0.639 FL	≤ 0.560 FL	≤ 0.585 FL			
Water cooled, electrically operated centrifugal	< 150 Tons	kW/ton	≤ 0.634 FL	≤ 0.639 FL	≤ 0.610 FL	≤ 0.695 FL	
	≥ 150 tons and < 300 tons		≤ 0.596 IPLV	≤ 0.450 IPLV	≤ 0.550 IPLV	≤ 0.440 IPLV	
			≤ 0.634 FL	≤ 0.639 FL	≤ 0.610 FL	≤ 0.635 FL	
	≥ 300 tons and < 400 tons		≤ 0.596 IPLV	≤ 0.450 IPLV	≤ 0.550 IPLV	≤ 0.400 IPLV	
			≤ 0.576 FL	≤ 0.600 FL	≤ 0.560 FL	≤ 0.595 FL	
	≥ 400 tons and < 600 tons		≤ 0.549 IPLV	≤ 0.400 IPLV	≤ 0.520 IPLV	≤ 0.390 IPLV	
			≤ 0.576 FL	≤ 0.600 FL	≤ 0.560 FL	≤ 0.585 FL	
	≥ 600 Tons		≤ 0.549 IPLV	≤ 0.400 IPLV	≤ 0.500 IPLV	≤ 0.380 IPLV	
≤ 0.570 FL		≤ 0.590 FL	≤ 0.560 FL	≤ 0.585 FL			
Air cooled, absorption, single effect	All capacities	COP	≥ 0.600 FL	NA ^c	≥ 0.600 FL	NA ^c	AHRI 560
Water cooled absorption, single effect	All capacities	COP	≥ 0.700 FL	NA ^c	≥ 0.700 FL	NA ^c	
Absorption, double effect, indirect fired	All capacities	COP	≥ 1.000 FL	NA ^c	≥ 1.000 FL	NA ^c	
			≥ 1.050 IPLV		≥ 1.050 IPLV		
Absorption double effect direct fired	All capacities	COP	≥ 1.000 FL	NA ^c	≥ 1.000 FL	NA ^c	
			≥ 1.000 IPLV		≥ 1.050 IPLV		

- a. The requirements for centrifugal chiller shall be adjusted for nonstandard rating conditions in accordance with Section C403.3.2.1 and are only applicable for the range of conditions listed in Section C403.3.2.1. The requirements for air-cooled, water-cooled positive displacement and absorption chillers are at standard rating conditions defined in the reference test procedure.
- b. Both the full-load and IPLV requirements shall be met or exceeded to comply with this standard. Where there is a Path B, compliance can be with either Path A or Path B for any application.
- c. NA means the requirements are not applicable for Path B and only Path A can be used for compliance.
- d. FL represents the full-load performance requirements and IPLV the part-load performance requirements.

TABLE C403.3.2(8)
MINIMUM EFFICIENCY REQUIREMENTS:
HEAT REJECTION EQUIPMENT

EQUIPMENT TYPE ^a	TOTAL SYSTEM HEAT REJECTION CAPACITY AT RATED CONDITIONS	SUBCATEGORY OR RATING CONDITION ⁱ	PERFORMANCE REQUIRED ^{b, c, d, g, h}	TEST PROCEDURE ^{e, f}
Propeller or axial fan open-circuit cooling towers	All	95°F entering water 85°F leaving water 75°F entering wb	≥ 40.2 gpm/hp	CTI ATC-105 and CTI STD-201 RS
Centrifugal fan open-circuit cooling towers	All	95°F entering water 85°F leaving water 75°F entering wb	≥ 20.0 gpm/hp	CTI ATC-105 and CTI STD-201 RS
Propeller or axial fan closed-circuit cooling towers	All	102°F entering water 90°F leaving water 75°F entering wb	≥ 16.1 gpm/hp	CTI ATC-105S and CTI STD-201 RS
Centrifugal fan closed-circuit cooling towers	All	102°F entering water 90°F leaving water 75°F entering wb	≥ 7.0 gpm/hp	CTI ATC-105S and CTI STD-201 RS
Propeller or axial fan evaporative condensers	All	Ammonia Test Fluid 140°F entering gas temperature 96.3°F condensing temperature 75°F entering wb	≥ 134,000 Btu/h × hp	CTI ATC-106
Centrifugal fan evaporative condensers	All	Ammonia Test Fluid 140°F entering gas temperature 96.3°F condensing temperature 75°F entering wb	≥ 110,000 Btu/h × hp	CTI ATC-106
Propeller or axial fan evaporative condensers	All	R-507A Test Fluid 165°F entering gas temperature 105°F condensing temperature 75°F entering wb	≥ 157,000 Btu/h × hp	CTI ATC-106
Centrifugal fan evaporative condensers	All	R-507A Test Fluid 165°F entering gas temperature 105°F condensing temperature 75°F entering wb	≥ 135,000 Btu/h × hp	CTI ATC-106
Air-cooled condensers	All	125°F Condensing Temperature 190°F Entering Gas Temperature 15°F subcooling 95°F entering db	≥ 176,000 Btu/h × hp	AHRI 460

For SI: °C = [(°F) - 32]/1.8, L/s • kW = (gpm/hp)/(11.83), COP = (Btu/h • hp)/(2550.7),
 db = dry bulb temperature, °F, wb = wet bulb temperature, °F.

- a. The efficiencies and test procedures for both open- and closed-circuit cooling towers are not applicable to hybrid cooling towers that contain a combination of wet and dry heat exchange sections.
- b. For purposes of this table, open circuit cooling tower performance is defined as the water flow rating of the tower at the thermal rating condition, divided by the fan nameplate-rated motor power.
- c. For purposes of this table, closed-circuit cooling tower performance is defined as the water flow rating of the tower at the thermal rating condition, divided by the sum of the fan nameplate-rated motor power and the spray pump nameplate-rated motor power.
- d. For purposes of this table, air-cooled condenser performance is defined as the heat rejected from the refrigerant divided by the fan nameplate-rated motor power.
- e. Chapter 6 contains a complete specification of the referenced test procedure, including the referenced year version of the test procedure. The certification requirements do not apply to field-erected cooling towers.
- f. Where a certification program exists for a covered product and it includes provisions for verification and challenge of equipment efficiency ratings, then the product shall be listed in the certification program; or, where a certification program exists for a covered product, and it includes provisions for verification and challenge of equipment efficiency ratings, but the product is not listed in the existing certification program, the ratings shall be verified by an independent laboratory test report.
- g. Cooling towers shall comply with the minimum efficiency listed in the table for that specific type of tower with the capacity effect of any project-specific accessories or options included in the capacity of the cooling tower
- h. For purposes of this table, evaporative condenser performance is defined as the heat rejected at the specified rating condition in the table divided by the sum of the fan motor nameplate power and the integral spray pump nameplate power
- i. Requirements for evaporative condensers are listed with ammonia (R-717) and R-507A as test fluids in the table. Evaporative condensers intended for use with halocarbon refrigerants other than R-507A shall meet the minimum efficiency requirements listed in this table with R-507A as the test fluid.

TABLE C403.3.2(9)
MINIMUM EFFICIENCY AIR CONDITIONERS AND CONDENSING UNITS SERVING COMPUTER ROOMS

EQUIPMENT TYPE	NET SENSIBLE COOLING CAPACITY ^a	MINIMUM SCOP-127 ^b EFFICIENCY DOWNFLOW UNITS / UPFLOW UNITS	TEST PROCEDURE
Air conditioners, air cooled	< 65,000 Btu/h	2.20 / 2.09	ANSI/ASHRAE 127
	≥ 65,000 Btu/h and < 240,000 Btu/h	2.10 / 1.99	
	≥ 240,000 Btu/h	1.90 / 1.79	
Air conditioners, water cooled	< 65,000 Btu/h	2.60 / 2.49	
	≥ 65,000 Btu/h and < 240,000 Btu/h	2.50 / 2.39	
	≥ 240,000 Btu/h	2.40 / 2.29	
Air conditioners, water cooled with fluid economizer	< 65,000 Btu/h	2.55 / 2.44	
	≥ 65,000 Btu/h and < 240,000 Btu/h	2.45 / 2.34	
	≥ 240,000 Btu/h	2.35 / 2.24	
Air conditioners, glycol cooled (rated at 40% propylene glycol)	< 65,000 Btu/h	2.50 / 2.39	
	≥ 65,000 Btu/h and < 240,000 Btu/h	2.15 / 2.04	
	≥ 240,000 Btu/h	2.10 / 1.99	
Air conditioners, glycol cooled (rated at 40% propylene glycol) with fluid economizer	< 65,000 Btu/h	2.45 / 2.34	
	≥ 65,000 Btu/h and < 240,000 Btu/h	2.10 / 1.99	
	≥ 240,000 Btu/h	2.05 / 1.94	

For SI: 1 British thermal unit per hour = 0.2931 W.

- a. Net sensible cooling capacity: the total gross cooling capacity less the latent cooling less the energy to the air movement system. (Total Gross – latent – Fan Power).
- b. Sensible coefficient of performance (SCOP-127): a ratio calculated by dividing the net sensible cooling capacity in watts by the total power input in watts (excluding reheaters and humidifiers) at conditions defined in ASHRAE Standard 127. The net sensible cooling capacity is the gross sensible capacity minus the energy dissipated into the cooled space by the fan system.

TABLE C403.3.2(10)
HEAT TRANSFER EQUIPMENT

EQUIPMENT TYPE	SUBCATEGORY	MINIMUM EFFICIENCY	TEST PROCEDURE ^a
Liquid-to-liquid heat exchangers	Plate type	NR	AHRI 400

NR = No Requirement.

- a. Chapter 6 contains a complete specification of the referenced test procedure, including the referenced year version of the test procedure.

C403.4.1.2 Deadband (Mandatory). Where used to control both heating and cooling, *zone* thermostatic controls shall be configured to provide a temperature range or deadband of not less than 5°F (2.8°C) within which the supply of heating and cooling energy to the *zone* is shut off or reduced to a minimum.

Exceptions:

- 1. Thermostats requiring manual changeover between heating and cooling modes.
- 2. Occupancies or applications requiring precision in indoor temperature control as *approved by the code official.*

C403.4.1.3 Setpoint overlap restriction (Mandatory). Where a *zone* has a separate heating and a separate cooling thermostatic control located within the *zone*, a limit switch, mechanical stop or direct digital control system with software programming shall be configured to prevent the heating setpoint from exceeding the cooling setpoint and to maintain a deadband in accordance with Section C403.4.1.2.

C403.4.1.4 Heated or cooled vestibules (Mandatory). The heating system for heated vestibules and air curtains with integral heating shall be provided with controls configured to shut off the source of heating when the outdoor air temperature is greater than 45°F (7°C). Vestibule heating and cooling systems shall be controlled by a thermostat located in the vestibule configured to limit heating to a temperature not greater than 60°F (16°C) and cooling to a temperature not less than 85°F (29°C).

Exception: Control of heating or cooling provided by site-recovered energy or transfer air that would otherwise be exhausted.

C403.4.1.5 Hot water boiler outdoor temperature setback control (Mandatory). Hot water boilers that supply heat to the building through one- or two-pipe heating systems shall have an outdoor setback control that lowers the boiler water temperature based on the outdoor temperature.

2. Automatically vary fluid flow for hydronic systems with a combined pump motor capacity of 2 hp (1.5 kW) or larger with three or more control valves or other devices by reducing the system design flow rate by not less than 50 percent or the maximum reduction allowed by the equipment manufacturer for proper operation of equipment by valves that modulate or step open and close, or pumps that modulate or turn on and off as a function of load.
3. Automatically vary pump flow on heating-water systems, chilled-water systems and heat rejection loops serving water-cooled unitary air conditioners as follows:
 - 3.1. Where pumps operate continuously or operate based on a time schedule, pumps with nominal output motor power of 2 hp or more shall have a variable speed drive.
 - 3.2. Where pumps have automatic direct digital control configured to operate pumps only when zone heating or cooling is required, a variable speed drive shall be provided for pumps with motors having the same or greater nominal output power indicated in Table C403.4.4 based on the climate zone and system served.
4. Where a variable speed drive is required by Item 3 of this Section, pump motor power input shall be not more than 30 percent of design wattage at 50 percent of the design water flow. Pump flow shall be controlled to maintain one control valve nearly wide open or to satisfy the minimum differential pressure.

Exceptions:

1. Supply-water temperature reset is not required for chilled-water systems supplied by off-site district chilled water or chilled water from ice storage systems.
2. Variable pump flow is not required on dedicated coil circulation pumps where needed for freeze protection.

3. Variable pump flow is not required on dedicated equipment circulation pumps where configured in primary/secondary design to provide the minimum flow requirements of the equipment manufacturer for proper operation of equipment.
4. Variable speed drives are not required on heating water pumps where more than 50 percent of annual heat is generated by an electric boiler.

C403.4.5 Pump isolation. Chilled water plants including more than one chiller shall be capable of and configured to reduce flow automatically through the chiller plant when a chiller is shut down. Chillers piped in series for the purpose of increased temperature differential shall be considered as one chiller.

Boiler systems including more than one boiler shall be capable of and configured to reduce flow automatically through the boiler system when a boiler is shut down.

C403.5 Economizers (Prescriptive). Economizers shall comply with Sections C403.5.1 through C403.5.5.

An air or water economizer shall be provided for the following cooling systems:

1. Chilled water systems with a total cooling capacity, less cooling capacity provided with air economizers, as specified in Table C403.5(1).
2. Individual fan systems with cooling capacity greater than or equal to 54,000 Btu/h (15.8 kW) in buildings having other than a *Group R* occupancy,

The total supply capacity of all fan cooling units not provided with economizers shall not exceed 20 percent of the total supply capacity of all fan cooling units in the building or 300,000 Btu/h (88 kW), whichever is greater.
3. Individual fan systems with cooling capacity greater than or equal to 270,000 Btu/h (79.1 kW) in buildings having a *Group R* occupancy,

The total supply capacity of all fan cooling units not provided with economizers shall not exceed 20 percent of the total supply capacity of all fan cooling units in

**TABLE C403.4.4
VARIABLE SPEED DRIVE (VSD) REQUIREMENTS FOR DEMAND-CONTROLLED PUMPS**

CHILLED WATER AND HEAT REJECTION LOOP PUMPS IN THESE CLIMATE ZONES	HEATING WATER PUMPS IN THESE CLIMATE ZONES	VSD REQUIRED FOR MOTORS WITH RATED OUTPUT OF:
1A, 1B, 2B	—	≥ 2 hp
2A, 3B	—	≥ 3 hp
3A, 3C, 4A, 4B	7, 8	≥ 5 hp
4C, 5A, 5B, 5C, 6A, 6B	3C, 5A, 5C, 6A, 6B	≥ 7.5 hp
—	4A, 4C, 5B	≥ 10 hp
7, 8	4B	≥ 15 hp
—	2A, 2B, 3A, 3B	≥ 25 hp
—	1B	≥ 100 hp
—	1A	≥ 200 hp

the building or 1,500,000 Btu/h (440 kW), whichever is greater.

Exceptions: Economizers are not required for the following systems.

1. Individual fan systems not served by chilled water for buildings located in *Climate Zones* 1A and 1B.
2. Where more than 25 percent of the air designed to be supplied by the system is to spaces that are designed to be humidified above 35°F (1.7°C) dew-point temperature to satisfy process needs.
3. Systems expected to operate less than 20 hours per week.
4. Systems serving supermarket areas with open refrigerated casework.
5. Where the cooling efficiency is greater than or equal to the efficiency requirements in Table C403.5(2).
6. Systems that include a heat recovery system in accordance with Section C403.9.5.

**TABLE C403.5(2)
EQUIPMENT EFFICIENCY PERFORMANCE
EXCEPTION FOR ECONOMIZERS**

CLIMATE ZONES	COOLING EQUIPMENT PERFORMANCE IMPROVEMENT (EER OR IPLV)
2A, 2B	10% efficiency improvement
3A, 3B	15% efficiency improvement
4A, 4B	20% efficiency improvement

C403.5.1 Integrated economizer control. Economizer systems shall be integrated with the mechanical cooling system and be configured to provide partial cooling even where additional mechanical cooling is required to provide the remainder of the cooling load. Controls shall not be capable of creating a false load in the mechanical cooling

systems by limiting or disabling the economizer or any other means, such as hot gas bypass, except at the lowest stage of mechanical cooling.

Units that include an air economizer shall comply with the following:

1. Unit controls shall have the mechanical cooling capacity control interlocked with the air economizer controls such that the outdoor air damper is at the 100-percent open position when mechanical cooling is on and the outdoor air damper does not begin to close to prevent coil freezing due to minimum compressor run time until the leaving air temperature is less than 45°F (7°C).
2. Direct expansion (DX) units that control 75,000 Btu/h (22 kW) or greater of rated capacity of the capacity of the mechanical cooling directly based on occupied space temperature shall have not fewer than two stages of mechanical cooling capacity.
3. Other DX units, including those that control space temperature by modulating the airflow to the space, shall be in accordance with Table C403.5.1.

C403.5.2 Economizer heating system impact. HVAC system design and economizer controls shall be such that economizer operation does not increase building heating energy use during normal operation.

Exception: Economizers on variable air volume (VAV) systems that cause zone level heating to increase because of a reduction in supply air temperature.

C403.5.3 Air economizers. Where economizers are required by Section C403.5, air economizers shall comply with Sections C403.5.3.1 through C403.5.3.5.

C403.5.3.1 Design capacity. Air economizer systems shall be configured to modulate *outdoor air* and return

**TABLE C403.5(1)
MINIMUM CHILLED-WATER SYSTEM COOLING CAPACITY FOR DETERMINING ECONOMIZER COOLING REQUIREMENTS**

CLIMATE ZONES (COOLING)	TOTAL CHILLED-WATER SYSTEM CAPACITY LESS CAPACITY OF COOLING UNITS WITH AIR ECONOMIZERS	
	Local Water-cooled Chilled-water Systems	Air-cooled Chilled-water Systems or District Chilled-Water Systems
1A	Economizer not required	Economizer not required
1B, 2A, 2B	960,000 Btu/h	1,250,000 Btu/h
3A, 3B, 3C, 4A, 4B, 4C	720,000 Btu/h	940,000 Btu/h
5A, 5B, 5C, 6A, 6B, 7, 8	1,320,000 Btu/h	1,720,000 Btu/h

For SI: 1 British thermal unit per hour = 0.2931 W.

**TABLE C403.5.1
DX COOLING STAGE REQUIREMENTS FOR MODULATING AIRFLOW UNITS**

RATING CAPACITY	MINIMUM NUMBER OF MECHANICAL COOLING STAGES	MINIMUM COMPRESSOR DISPLACEMENT ^a
≥ 65,000 Btu/h and < 240,000 Btu/h	3 stages	≤ 35% of full load
≥ 240,000 Btu/h	4 stages	≤ 25% full load

For SI: 1 British thermal unit per hour = 0.2931 W.

a. For mechanical cooling stage control that does not use variable compressor displacement, the percent displacement shall be equivalent to the mechanical cooling capacity reduction evaluated at the full load rating conditions for the compressor.

air dampers to provide up to 100 percent of the design supply air quantity as *outdoor air* for cooling.

C403.5.3.2 Control signal. Economizer controls and dampers shall be configured to sequence the dampers with the mechanical cooling equipment and shall not be controlled by only mixed-air temperature.

Exception: The use of mixed-air temperature limit control shall be permitted for systems controlled from space temperature (such as single-zone systems).

C403.5.3.3 High-limit shutoff. Air economizers shall be configured to automatically reduce *outdoor air* intake to the design minimum *outdoor air* quantity when *outdoor air* intake will not reduce cooling energy usage. High-limit shutoff control types for specific climates shall be chosen from Table C403.5.3.3. High-limit shutoff control settings for these control types shall be those specified in Table C403.5.3.3.

C403.5.3.4 Relief of excess outdoor air. Systems shall be capable of relieving excess *outdoor air* during air economizer operation to prevent overpressurizing the building. The relief air outlet shall be located to avoid recirculation into the building.

C403.5.3.5 Economizer dampers. Return, exhaust/relief and outdoor air dampers used in economizers shall comply with Section C403.7.7.

C403.5.4 Water-side economizers. Where economizers are required by Section C403.5, water-side economizers shall comply with Sections C403.5.4.1 and C403.5.4.2.

C403.5.4.1 Design capacity. Water economizer systems shall be configured to cool supply air by indirect evaporation and providing up to 100 percent of the

expected system cooling load at *outdoor air* temperatures of not greater than 50°F (10°C) dry bulb/45°F (7°C) wet bulb.

Exceptions:

1. Systems primarily serving computer rooms in which 100 percent of the expected system cooling load at 40°F (4°C) dry bulb/35°F (1.7°C) wet bulb is met with evaporative water economizers.
2. Systems primarily serving computer rooms with dry cooler water economizers that satisfy 100 percent of the expected system cooling load at 35°F (1.7°C) dry bulb.
3. Systems where dehumidification requirements cannot be met using outdoor air temperatures of 50°F (10°C) dry bulb/45°F (7°C) wet bulb and where 100 percent of the expected system cooling load at 45°F (7°C) dry bulb/40°F (4°C) wet bulb is met with evaporative water economizers.

C403.5.4.2 Maximum pressure drop. Precooling coils and water-to-water heat exchangers used as part of a water economizer system shall either have a water-side pressure drop of less than 15 feet (45 kPa) of water or a secondary loop shall be created so that the coil or heat exchanger pressure drop is not seen by the circulating pumps when the system is in the normal cooling (noneconomizer) mode.

C403.5.5 Economizer fault detection and diagnostics (Mandatory). Air-cooled unitary direct-expansion units listed in Tables C403.3.2(1) through C403.3.2(3) and variable refrigerant flow (VRF) units that are equipped with an

**TABLE C403.5.3.3
HIGH-LIMIT SHUTOFF CONTROL SETTING FOR AIR ECONOMIZERS^b**

DEVICE TYPE	CLIMATE ZONE	REQUIRED HIGH LIMIT (ECONOMIZER OFF WHEN):	
		Equation	Description
Fixed dry bulb	1B, 2B, 3B, 3C, 4B, 4C, 5B, 5C, 6B, 7, 8	$T_{OA} > 75^{\circ}\text{F}$	Outdoor air temperature exceeds 75°F
	5A, 6A	$T_{OA} > 70^{\circ}\text{F}$	Outdoor air temperature exceeds 70°F
	1A, 2A, 3A, 4A	$T_{OA} > 65^{\circ}\text{F}$	Outdoor air temperature exceeds 65°F
Differential dry bulb	1B, 2B, 3B, 3C, 4B, 4C, 5A, 5B, 5C, 6A, 6B, 7, 8	$T_{OA} > T_{RA}$	Outdoor air temperature exceeds return air temperature
Fixed enthalpy with fixed dry-bulb temperatures	All	$h_{OA} > 28 \text{ Btu/lb}^a$ or $T_{OA} > 75^{\circ}\text{F}$	Outdoor air enthalpy exceeds 28 Btu/lb of dry air ^a or Outdoor air temperature exceeds 75°F
Differential enthalpy with fixed dry-bulb temperature	All	$h_{OA} > h_{RA}$ or $T_{OA} > 75^{\circ}\text{F}$	Outdoor air enthalpy exceeds return air enthalpy or Outdoor air temperature exceeds 75°F

For SI: 1 foot = 305 mm, °C = (°F - 32)/1.8, 1 Btu/lb = 2.33 kJ/kg.

- a. At altitudes substantially different than sea level, the fixed enthalpy limit shall be set to the enthalpy value at 75°F and 50-percent relative humidity. As an example, at approximately 6,000 feet elevation, the fixed enthalpy limit is approximately 30.7 Btu/lb.
- b. Devices with selectable setpoints shall be capable of being set to within 2°F and 2 Btu/lb of the setpoint listed.

- Garages that have a garage area to ventilation system motor nameplate power ratio that exceeds 1125 cfm/hp (710 L/s/kW) and do not utilize heating or mechanical cooling.

C403.7.3 Ventilation air heating control (Mandatory).

Units that provide ventilation air to multiple zones and operate in conjunction with zone heating and cooling systems shall not use heating or heat recovery to warm supply air to a temperature greater than 60°F (16°C) when representative building loads or outdoor air temperatures indicate that the majority of zones require cooling.

C403.7.4 Energy recovery ventilation systems (Mandatory).

Where the supply airflow rate of a fan system exceeds the values specified in Tables C403.7.4(1) and C403.7.4(2), the system shall include an energy recovery system. The energy recovery system shall be configured to provide a change in the enthalpy of the outdoor air supply of not less than 50 percent of the difference between the outdoor air and return air enthalpies, at design conditions. Where an air economizer is required, the energy recovery system shall include a bypass or controls that permit operation of the economizer as required by Section C403.5.

Exception: An energy recovery ventilation system shall not be required in any of the following conditions:

- Where energy recovery systems are prohibited by the *International Mechanical Code*.

- Laboratory fume hood systems that include not fewer than one of the following features:

2.1. Variable-air-volume hood exhaust and room supply systems configured to reduce exhaust and makeup air volume to 50 percent or less of design values.

2.2. Direct makeup (auxiliary) air supply equal to or greater than 75 percent of the exhaust rate, heated not warmer than 2°F (1.1°C) above room setpoint, cooled to not cooler than 3°F (1.7°C) below room setpoint, with no humidification added, and no simultaneous heating and cooling used for dehumidification control.

- Systems serving spaces that are heated to less than 60°F (15.5°C) and that are not cooled.
- Where more than 60 percent of the outdoor heating energy is provided from site-recovered or site-solar energy.
- Heating energy recovery in *Climate Zones 1 and 2*.
- Cooling energy recovery in *Climate Zones 3C, 4C, 5B, 5C, 6B, 7 and 8*.

**TABLE C403.7.4(1)
ENERGY RECOVERY REQUIREMENT
(Ventilation systems operating less than 8,000 hours per year)**

CLIMATE ZONE	PERCENT (%) OUTDOOR AIR AT FULL DESIGN AIRFLOW RATE							
	≥ 10% and < 20%	≥ 20% and < 30%	≥ 30% and < 40%	≥ 40% and < 50%	≥ 50% and < 60%	≥ 60% and < 70%	≥ 70% and < 80%	≥ 80%
DESIGN SUPPLY FAN AIRFLOW RATE (cfm)								
3B, 3C, 4B, 4C, 5B	NR	NR	NR	NR	NR	NR	NR	NR
1B, 2B, 5C	NR	NR	NR	NR	≥ 26,000	≥ 12,000	≥ 5,000	≥ 4,000
6B	≥ 28,000	≥ 26,500	≥ 11,000	≥ 5,500	≥ 4,500	≥ 3,500	≥ 2,500	≥ 1,500
1A, 2A, 3A, 4A, 5A, 6A	≥ 26,000	≥ 16,000	≥ 5,500	≥ 4,500	≥ 3,500	≥ 2,000	≥ 1,000	> 120
7, 8	≥ 4,500	≥ 4,000	≥ 2,500	≥ 1,000	>140	> 120	> 100	> 80

For SI: 1 cfm = 0.4719 L/s.
NR = Not Required.

**TABLE C403.7.4(2)
ENERGY RECOVERY REQUIREMENT
(Ventilation systems operating not less than 8,000 hours per year)**

CLIMATE ZONE	PERCENT (%) OUTDOOR AIR AT FULL DESIGN AIRFLOW RATE							
	≥ 10% and < 20%	≥ 20% and < 30%	≥ 30% and < 40%	≥ 40% and < 50%	≥ 50% and < 60%	≥ 60% and < 70%	≥ 70% and < 80%	≥ 80%
Design Supply Fan Airflow Rate (cfm)								
3C	NR	NR	NR	NR	NR	NR	NR	NR
1B, 2B, 3B, 4C, 5C	NR	≥ 19,500	≥ 9,000	≥ 5,000	≥ 4,000	≥ 3,000	≥ 1,500	≥ 120
1A, 2A, 3A, 4B, 5B	≥ 2,500	≥ 2,000	≥ 1,000	≥ 500	≥ 140	≥ 120	≥ 100	≥ 80
4A, 5A, 6A, 6B, 7, 8	≥ 200	≥ 130	≥ 100	≥ 80	≥ 70	≥ 60	≥ 50	≥ 40

For SI: 1 cfm = 0.4719 L/s.
NR = Not Required.

7. Systems requiring dehumidification that employ energy recovery in series with the cooling coil.
8. Where the largest source of air exhausted at a single location at the building exterior is less than 75 percent of the design *outdoor air* flow rate.
9. Systems expected to operate less than 20 hours per week at the *outdoor air* percentage covered by Table C403.7.4(1).
10. Systems exhausting toxic, flammable, paint or corrosive fumes or dust.
11. Commercial kitchen hoods used for collecting and removing grease vapors and smoke.

C403.7.5 Kitchen exhaust systems (Mandatory). Replacement air introduced directly into the exhaust hood cavity shall not be greater than 10 percent of the hood exhaust airflow rate. Conditioned supply air delivered to any space shall not exceed the greater of the following:

1. The ventilation rate required to meet the space heating or cooling load.
2. The hood exhaust flow minus the available transfer air from adjacent space where available transfer air is considered to be that portion of outdoor ventilation air not required to satisfy other exhaust needs, such as restrooms, and not required to maintain pressurization of adjacent spaces.

Where total kitchen hood exhaust airflow rate is greater than 5,000 cfm (2360 L/s), each hood shall be a factory-built commercial exhaust hood listed by a nationally recognized testing laboratory in compliance with UL 710. Each hood shall have a maximum exhaust rate as specified in Table C403.7.5 and shall comply with one of the following:

1. Not less than 50 percent of all replacement air shall be transfer air that would otherwise be exhausted.
2. Demand ventilation systems on not less than 75 percent of the exhaust air that are configured to provide not less than a 50-percent reduction in exhaust and replacement air system airflow rates, including controls necessary to modulate airflow in response to appliance operation and to maintain full capture and

containment of smoke, effluent and combustion products during cooking and idle.

3. Listed energy recovery devices with a sensible heat recovery effectiveness of not less than 40 percent on not less than 50 percent of the total exhaust airflow.

Where a single hood, or hood section, is installed over appliances with different duty ratings, the maximum allowable flow rate for the hood or hood section shall be based on the requirements for the highest appliance duty rating under the hood or hood section.

Exception: Where not less than 75 percent of all the replacement air is transfer air that would otherwise be exhausted.

C403.7.6 Automatic control of HVAC systems serving guestrooms (Mandatory). In *Group R-1* buildings containing more than 50 guestrooms, each guestroom shall be provided with controls complying with the provisions of Sections C403.7.6.1 and C403.7.6.2. Card key controls comply with these requirements.

C403.7.6.1 Temperature setpoint controls. Controls shall be provided on each HVAC system that are capable of and configured to automatically raise the cooling setpoint and lower the heating setpoint by not less than 4°F (2°C) from the occupant setpoint within 30 minutes after the occupants have left the guestroom. The controls shall be capable of and configured to automatically raise the cooling setpoint to not lower than 80°F (27°C) and lower the heating setpoint to not higher than 60°F (16°C) when the guestroom is unrented or has not been continuously occupied for more than 16 hours or a *networked guestroom control system* indicates that the guestroom is unrented and the guestroom is unoccupied for more than 30 minutes. A *networked guestroom control system* that is capable of returning the thermostat setpoints to default occupied setpoints 60 minutes prior to the time a guestroom is scheduled to be occupied is not precluded by this section. Cooling that is capable of limiting relative humidity with a setpoint not lower than 65-percent relative humidity during unoccupied periods is not precluded by this section.

C403.7.6.2 Ventilation controls. Controls shall be provided on each HVAC system that are capable of and configured to automatically turn off the ventilation and

**TABLE C403.7.5
MAXIMUM NET EXHAUST FLOW RATE,
CFM PER LINEAR FOOT OF HOOD LENGTH**

TYPE OF HOOD	LIGHT-DUTY EQUIPMENT	MEDIUM-DUTY EQUIPMENT	HEAVY-DUTY EQUIPMENT	EXTRA-HEAVY-DUTY EQUIPMENT
Wall-mounted canopy	140	210	280	385
Single island	280	350	420	490
Double island (per side)	175	210	280	385
Eyebrow	175	175	NA	NA
Backshelf/Pass-over	210	210	280	NA

For SI: 1 cfm = 0.4719 L/s; 1 foot = 305 mm.

NA = Not Allowed.

exhaust fans within 30 minutes of the occupants leaving the guestroom, or *isolation devices* shall be provided to each guestroom that are capable of automatically shutting off the supply of outdoor air to and exhaust air from the guestroom.

Exception: Guestroom ventilation systems are not precluded from having an automatic daily pre-occupancy purge cycle that provides daily outdoor air ventilation during unrented periods at the design ventilation rate for 60 minutes, or at a rate and duration equivalent to one air change.

C403.7.7 Shutoff dampers (Mandatory). Outdoor air intake and exhaust openings and stairway and shaft vents shall be provided with Class I motorized dampers. The dampers shall have an air leakage rate not greater than 4 cfm/ft² (20.3 L/s • m²) of damper surface area at 1.0 inch water gauge (249 Pa) and shall be labeled by an approved agency when tested in accordance with AMCA 500D for such purpose.

Outdoor air intake and exhaust dampers shall be installed with automatic controls configured to close when the systems or spaces served are not in use or during unoccupied period warm-up and setback operation, unless the systems served require outdoor or exhaust air in accordance with the *International Mechanical Code* or the dampers are opened to provide intentional economizer cooling.

Stairway and shaft vent dampers shall be installed with automatic controls configured to open upon the activation of any fire alarm initiating device of the building's fire alarm system or the interruption of power to the damper.

Exception: Nonmotorized gravity dampers shall be an alternative to motorized dampers for exhaust and relief openings as follows:

1. In buildings less than three stories in height above grade plane.
2. In buildings of any height located in *Climate Zones* 1, 2 or 3.
3. Where the design exhaust capacity is not greater than 300 cfm (142 L/s).

Nonmotorized gravity dampers shall have an air leakage rate not greater than 20 cfm/ft² (101.6 L/s • m²) where not less than 24 inches (610 mm) in either dimension and

40 cfm/ft² (203.2 L/s • m²) where less than 24 inches (610 mm) in either dimension. The rate of air leakage shall be determined at 1.0 inch water gauge (249 Pa) when tested in accordance with AMCA 500D for such purpose. The dampers shall be labeled by an approved agency.

C403.8 Fans and fan controls. Fans in HVAC systems shall comply with Sections C403.8.1 through C403.8.5.1.

C403.8.1 Allowable fan horsepower (Mandatory). Each HVAC system having a total fan system motor nameplate horsepower exceeding 5 hp (3.7 kW) at fan system design conditions shall not exceed the allowable *fan system motor nameplate hp* (Option 1) or *fan system bhp* (Option 2) shown in Table C403.8.1(1). This includes supply fans, exhaust fans, return/relief fans, and fan-powered terminal units associated with systems providing heating or cooling capability. Single-zone variable air volume systems shall comply with the constant volume fan power limitation.

Exceptions:

1. Hospital, vivarium and laboratory systems that utilize flow control devices on exhaust or return to maintain space pressure relationships necessary for occupant health and safety or environmental control shall be permitted to use variable volume fan power limitation.
2. Individual exhaust fans with motor nameplate horsepower of 1 hp (0.746 kW) or less are exempt from the allowable fan horsepower requirement.

C403.8.2 Motor nameplate horsepower (Mandatory). For each fan, the fan brake horsepower shall be indicated on the construction documents and the selected motor shall be not larger than the first available motor size greater than the following:

1. For fans less than 6 bhp (4413 W), 1.5 times the fan brake horsepower.
2. For fans 6 bhp (4413 W) and larger, 1.3 times the fan brake horsepower.
3. Systems complying with Section C403.8.1 *fan system motor nameplate hp* (Option 1).

Exception: Fans with motor nameplate horsepower less than 1 hp (746 W) are exempt from this section.

**TABLE C403.8.1(1)
FAN POWER LIMITATION**

	LIMIT	CONSTANT VOLUME	VARIABLE VOLUME
Option 1: Fan system motor nameplate hp	Allowable nameplate motor hp	$hp \leq CFM_s \times 0.0011$	$hp \leq CFM_s \times 0.0015$
Option 2: Fan system bhp	Allowable fan system bhp	$bhp \leq CFM_s \times 0.00094 + A$	$bhp \leq CFM_s \times 0.0013 + A$

For SI: 1 bhp = 735.5 W, 1 hp = 745.5 W, 1 cfm = 0.4719 L/s.

where:

CFM_s = The maximum design supply airflow rate to conditioned spaces served by the system in cubic feet per minute.

hp = The maximum combined motor nameplate horsepower.

bhp = The maximum combined fan brake horsepower.

A = Sum of [PD × CFM_d / 4131].

where:

PD = Each applicable pressure drop adjustment from Table C403.8.1(2) in. w.c.

CFM_d = The design airflow through each applicable device from Table C403.8.1(2) in cubic feet per minute.

TABLE C403.8.1(2)
FAN POWER LIMITATION PRESSURE DROP ADJUSTMENT

DEVICE	ADJUSTMENT
Credits	
Return air or exhaust systems required by code or accreditation standards to be fully ducted, or systems required to maintain air pressure differentials between adjacent rooms	0.5 inch w.c. (2.15 inches w.c. for laboratory and vivarium systems)
Return and exhaust airflow control devices	0.5 inch w.c.
Exhaust filters, scrubbers or other exhaust treatment	The pressure drop of device calculated at fan system design condition
Particulate filtration credit: MERV 9 thru 12	0.5 inch w.c.
Particulate filtration credit: MERV 13 thru 15	0.9 inch w.c.
Particulate filtration credit: MERV 16 and greater and electronically enhanced filters	Pressure drop calculated at 2x clean filter pressure drop at fan system design condition.
Carbon and other gas-phase air cleaners	Clean filter pressure drop at fan system design condition.
Biosafety cabinet	Pressure drop of device at fan system design condition.
Energy recovery device, other than coil runaround loop	For each airstream, (2.2 × energy recovery effectiveness – 0.5) inch w.c.
Coil runaround loop	0.6 inch w.c. for each airstream.
Evaporative humidifier/cooler in series with another cooling coil	Pressure drop of device at fan system design conditions.
Sound attenuation section (fans serving spaces with design background noise goals below NC35)	0.15 inch w.c.
Exhaust system serving fume hoods	0.35 inch w.c.
Laboratory and vivarium exhaust systems in high-rise buildings	0.25 inch w.c./100 feet of vertical duct exceeding 75 feet.
Deductions	
Systems without central cooling device	- 0.6 inch w.c.
Systems without central heating device	- 0.3 inch w.c.
Systems with central electric resistance heat	- 0.2 inch w.c.

For SI: 1 inch w.c. = 249 Pa, 1 inch = 25.4 mm.
w.c. = water column, NC = Noise criterion.

C403.8.3 Fan efficiency (Mandatory). Fans shall have a fan efficiency grade (FEG) of not less than 67, as determined in accordance with AMCA 205 by an *approved*, independent testing laboratory and labeled by the manufacturer. The total efficiency of the fan at the design point of operation shall be within 15 percentage points of the maximum total efficiency of the fan.

Exception: The following fans are not required to have a fan efficiency grade:

1. Fans of 5 hp (3.7 kW) or less as follows:
 - 1.1. Individual fans with a motor nameplate horsepower of 5 hp (3.7 kW) or less, unless Exception 1.2 applies.
 - 1.2. Multiple fans in series or parallel that have a combined motor nameplate horsepower of 5 hp (3.7 kW) or less and are operated as the functional equivalent of a single fan.
2. Fans that are part of equipment covered in Section C403.3.2.

3. Fans included in an equipment package certified by an *approved agency* for air or energy performance.
4. Powered wall/roof ventilators.
5. Fans outside the scope of AMCA 205.
6. Fans that are intended to operate only during emergency conditions.

C403.8.4 Fractional hp fan motors (Mandatory). Motors for fans that are not less than $\frac{1}{12}$ hp (0.082 kW) and less than 1 hp (0.746 kW) shall be electronically commutated motors or shall have a minimum motor efficiency of 70 percent, rated in accordance with DOE 10 CFR 431. These motors shall have the means to adjust motor speed for either balancing or remote control. The use of belt-driven fans to sheave adjustments for airflow balancing instead of a varying motor speed shall be permitted.

Exceptions: The following motors are not required to comply with this section:

1. Motors in the airstream within fan coils and terminal units that only provide heating to the space served.

2. Motors in space-conditioning equipment that comply with Section C403.3.2 or Sections C403.8.1. through C403.8.3.
3. Motors that comply with Section C405.7.

C403.8.5 Fan control. Controls shall be provided for fans in accordance with Section C403.8.5.1 and as required for specific systems provided in Section C403.

C403.8.5.1 Fan airflow control. Each cooling system listed in Table C403.8.5.1 shall be designed to vary the indoor fan airflow as a function of load and shall comply with the following requirements:

1. Direct expansion (DX) and chilled water cooling units that control the capacity of the mechanical cooling directly based on space temperature shall have not fewer than two stages of fan control. Low or minimum speed shall not be greater than 66 percent of full speed. At low or minimum speed, the fan system shall draw not more than 40 percent of the fan power at full fan speed. Low or minimum speed shall be used during periods of low cooling load and ventilation-only operation.
2. Other units including DX cooling units and chilled water units that control the space temperature by modulating the airflow to the space shall have modulating fan control. Minimum speed shall be not greater than 50 percent of full speed. At minimum speed the fan system shall draw not more than 30 percent of the power at full fan speed. Low or minimum speed shall be used during periods of low cooling load and ventilation-only operation.
3. Units that include an air-side economizer in accordance with Section C403.5 shall have not fewer than two speeds of fan control during economizer operation.

Exceptions:

1. Modulating fan control is not required for chilled water and evaporative cooling units with fan motors of less than 1 hp (0.746 kW) where the units are not used to provide *ventilation air* and the indoor fan cycles with the load.
2. Where the volume of outdoor air required to comply with the ventilation requirements of the *International Mechanical Code* at low speed exceeds the air that would be delivered at the speed defined in Section C403.8.5, the minimum speed shall be selected to provide the required *ventilation air*.

**TABLE C403.8.5.1
COOLING SYSTEMS**

COOLING SYSTEM TYPE	FAN MOTOR SIZE	MECHANICAL COOLING CAPACITY
DX cooling	Any	≥ 65,000 Btu/h
Chilled water and evaporative cooling	≥ 1/4 hp	Any

For SI: 1 British thermal unit per hour = 0.2931 W; 1 hp = 0.746 kW.

C403.9 Heat rejection equipment. Heat rejection equipment, including air-cooled condensers, dry coolers, open-circuit cooling towers, closed-circuit cooling towers and evaporative condensers, shall comply with this section.

Exception: Heat rejection devices where energy usage is included in the equipment efficiency ratings listed in Tables C403.3.2(6) and C403.3.2(7).

C403.9.1 Fan speed control. Each fan system powered by an individual motor or array of motors with connected power, including the motor service factor, totaling 5 hp (3.7 kW) or more shall have controls and devices configured to automatically modulate the fan speed to control the leaving fluid temperature or condensing temperature and pressure of the heat rejection device. Fan motor power input shall be not more than 30 percent of design wattage or 50 percent of the design airflow.

Exceptions:

1. Fans serving multiple refrigerant or fluid cooling circuits.
2. Condenser fans serving flooded condensers.

C403.9.2 Multiple-cell heat rejection equipment. Multiple-cell heat rejection equipment with variable speed fan drives shall be controlled to operate the maximum number of fans allowed that comply with the manufacturer's requirements for all system components and so that all fans operate at the same fan speed required for the instantaneous cooling duty, as opposed to staged on and off operation. The minimum fan speed shall be the minimum allowable speed of the fan drive system in accordance with the manufacturer's recommendations.

C403.9.3 Limitation on centrifugal fan open-circuit cooling towers. Centrifugal fan open-circuit cooling towers with a combined rated capacity of 1,100 gpm (4164 L/m) or greater at 95°F (35°C) condenser water return, 85°F (29°C) condenser water supply, and 75°F (24°C) outdoor air wet-bulb temperature shall meet the energy efficiency requirement for axial fan open-circuit cooling towers listed in Table C403.3.2(8).

Exception: Centrifugal open-circuit cooling towers that are designed with inlet or discharge ducts or require external sound attenuation.

C403.9.4 Tower flow turndown. Open-circuit cooling towers used on water-cooled chiller systems that are configured with multiple- or variable-speed condenser water pumps shall be designed so that all open-circuit cooling tower cells can be run in parallel with the larger of the flow that is produced by the smallest pump at its minimum expected flow rate or at 50 percent of the design flow for the cell.

C403.9.5 Heat recovery for service water heating. Condenser heat recovery shall be installed for heating or reheating of service hot water provided that the facility operates 24 hours a day, the total installed heat capacity of water-cooled systems exceeds 6,000,000 Btu/hr (1 758 kW) of heat rejection, and the design service water heating load exceeds 1,000,000 Btu/h (293 kW).

TABLE C403.10.1(1)
MINIMUM EFFICIENCY REQUIREMENTS: COMMERCIAL REFRIGERATION

EQUIPMENT TYPE	APPLICATION	ENERGY USE LIMITS (kWh per day) ^a	TEST PROCEDURE
Refrigerator with solid doors	Holding Temperature	$0.10 \times V + 2.04$	AHRI 1200
Refrigerator with transparent doors		$0.12 \times V + 3.34$	
Freezers with solid doors		$0.40 \times V + 1.38$	
Freezers with transparent doors		$0.75 \times V + 4.10$	
Refrigerators/freezers with solid doors		the greater of $0.12 \times V + 3.34$ or 0.70	
Commercial refrigerators	Pulldown	$0.126 \times V + 3.51$	

a. V = volume of the chiller or frozen compartment as defined in AHAM-HRF-1.

TABLE C403.10.1(2)
MINIMUM EFFICIENCY REQUIREMENTS: COMMERCIAL REFRIGERATORS AND FREEZERS

EQUIPMENT TYPE				ENERGY USE LIMITS (kWh/day) ^{a, b}	TEST PROCEDURE
Equipment Class ^c	Family Code	Operating Mode	Rating Temperature		
VOP.RC.M	Vertical open	Remote condensing	Medium	$0.82 \times TDA + 4.07$	AHRI 1200
SVO.RC.M	Semivertical open	Remote condensing	Medium	$0.83 \times TDA + 3.18$	
HZO.RC.M	Horizontal open	Remote condensing	Medium	$0.35 \times TDA + 2.88$	
VOP.RC.L	Vertical open	Remote condensing	Low	$2.27 \times TDA + 6.85$	
HZO.RC.L	Horizontal open	Remote condensing	Low	$0.57 \times TDA + 6.88$	
VCT.RC.M	Vertical transparent door	Remote condensing	Medium	$0.22 \times TDA + 1.95$	
VCT.RC.L	Vertical transparent door	Remote condensing	Low	$0.56 \times TDA + 2.61$	
SOC.RC.M	Service over counter	Remote condensing	Medium	$0.51 \times TDA + 0.11$	
VOP.SC.M	Vertical open	Self-contained	Medium	$1.74 \times TDA + 4.71$	
SVO.SC.M	Semivertical open	Self-contained	Medium	$1.73 \times TDA + 4.59$	
HZO.SC.M	Horizontal open	Self-contained	Medium	$0.77 \times TDA + 5.55$	
HZO.SC.L	Horizontal open	Self-contained	Low	$1.92 \times TDA + 7.08$	
VCT.SC.I	Vertical transparent door	Self-contained	Ice cream	$0.67 \times TDA + 3.29$	
VCS.SC.I	Vertical solid door	Self-contained	Ice cream	$0.38 \times V + 0.88$	
HCT.SC.I	Horizontal transparent door	Self-contained	Ice cream	$0.56 \times TDA + 0.43$	
SVO.RC.L	Semivertical open	Remote condensing	Low	$2.27 \times TDA + 6.85$	
VOP.RC.I	Vertical open	Remote condensing	Ice cream	$2.89 \times TDA + 8.7$	
SVO.RC.I	Semivertical open	Remote condensing	Ice cream	$2.89 \times TDA + 8.7$	
HZO.RC.I	Horizontal open	Remote condensing	Ice cream	$0.72 \times TDA + 8.74$	
VCT.RC.I	Vertical transparent door	Remote condensing	Ice cream	$0.66 \times TDA + 3.05$	
HCT.RC.M	Horizontal transparent door	Remote condensing	Medium	$0.16 \times TDA + 0.13$	

(continued)

TABLE C403.10.1(2)—continued
MINIMUM EFFICIENCY REQUIREMENTS: COMMERCIAL REFRIGERATORS AND FREEZERS

EQUIPMENT TYPE				ENERGY USE LIMITS (kWh/day) ^{a, b}	TEST PROCEDURE
Equipment Class ^c	Family Code	Operating Mode	Rating Temperature		
HCT.RC.L	Horizontal transparent door	Remote condensing	Low	$0.34 \times TDA + 0.26$	AHRI 1200
HCT.RC.I	Horizontal transparent door	Remote condensing	Ice cream	$0.4 \times TDA + 0.31$	
VCS.RC.M	Vertical solid door	Remote condensing	Medium	$0.11 \times V + 0.26$	
VCS.RC.L	Vertical solid door	Remote condensing	Low	$0.23 \times V + 0.54$	
VCS.RC.I	Vertical solid door	Remote condensing	Ice cream	$0.27 \times V + 0.63$	
HCS.RC.M	Horizontal solid door	Remote condensing	Medium	$0.11 \times V + 0.26$	
HCS.RC.L	Horizontal solid door	Remote condensing	Low	$0.23 \times V + 0.54$	
HCS.RC.I	Horizontal solid door	Remote condensing	Ice cream	$0.27 \times V + 0.63$	
HCS.RC.I	Horizontal solid door	Remote condensing	Ice cream	$0.27 \times V + 0.63$	
SOC.RC.L	Service over counter	Remote condensing	Low	$1.08 \times TDA + 0.22$	
SOC.RC.I	Service over counter	Remote condensing	Ice cream	$1.26 \times TDA + 0.26$	
VOP.SC.L	Vertical open	Self-contained	Low	$4.37 \times TDA + 11.82$	
VOP.SC.I	Vertical open	Self-contained	Ice cream	$5.55 \times TDA + 15.02$	
SVO.SC.L	Semivertical open	Self-contained	Low	$4.34 \times TDA + 11.51$	
SVO.SC.I	Semivertical open	Self-contained	Ice cream	$5.52 \times TDA + 14.63$	
HZO.SC.I	Horizontal open	Self-contained	Ice cream	$2.44 \times TDA + 9.0$	
SOC.SC.I	Service over counter	Self-contained	Ice cream	$1.76 \times TDA + 0.36$	
HCS.SC.I	Horizontal solid door	Self-contained	Ice cream	$0.38 \times V + 0.88$	

- a. V = Volume of the case, as measured in accordance with Appendix C of AHRI 1200.
- b. TDA = Total display area of the case, as measured in accordance with Appendix D of AHRI 1200.
- c. Equipment class designations consist of a combination [in sequential order separated by periods (AAA).(BB).(C)] of:
 - (AAA) An equipment family code where:
 - VOP = vertical open
 - SVO = semivertical open
 - HZO = horizontal open
 - HCT = horizontal transparent doors
 - HCS = horizontal solid doors
 - SOC = service over counter
 - (BB) An operating mode code:
 - RC = remote condensing
 - SC = self-contained
 - (C) A rating temperature code:
 - M = medium temperature (38°F)
 - L = low temperature (0°F)
 - I = ice-cream temperature (15°F)

For example, “VOP.RC.M” refers to the “vertical-open, remote-condensing, medium-temperature” equipment class.

- 6. Transparent reach-in doors for and windows in opaque *walk-in cooler* doors shall be double-pane heat-reflective treated glass having the interstitial space gas filled.

- 7. Evaporator fan motors that are less than 1 hp (0.746 kW) and less than 460 volts shall be electronically commutated motors or 3-phase motors.
- 8. Condenser fan motors that are less than 1 hp (0.746 kW) in capacity shall be of the electronic type.

cally commutated or permanent split capacitor-type or shall be 3-phase motors.

Exception: Fan motors in *walk-in coolers* and *walk-in freezers* combined in a single enclosure greater than 3,000 square feet (279 m²) in floor area are exempt.

9. Antisweat heaters that are not provided with anti-sweat heater controls shall have a total door rail, glass and frame heater power draw not greater than 7.1 W/ft² (76 W/m²) of door opening for *walk-in freezers*, and not greater than 3.0 W/ft² (32 W/m²) of door opening for *walk-in coolers*.
10. Antisweat heater controls shall be configured to reduce the energy use of the antisweat heater as a function of the relative humidity in the air outside the door or to the condensation on the inner glass pane.
11. Light sources shall have an efficacy of not less than 40 lumens per Watt, including any ballast losses, or shall be provided with a device that automatically turns off the lights within 15 minutes of when the *walk-in cooler* or *walk-in freezer* was last occupied.

C403.10.2.1 Performance standards (Mandatory). Effective January 1, 2020, *walk-in coolers* and *walk-in freezers* shall meet the requirements of Tables C403.10.2.1(1), C403.10.2.1(2) and C403.10.2.1(3).

C403.10.3 Refrigerated display cases (Mandatory). Site-assembled or site-constructed refrigerated display cases shall comply with the following:

1. Lighting and glass doors in refrigerated display cases shall be controlled by one of the following:
 - 1.1. Time-switch controls to turn off lights during nonbusiness hours. Timed overrides for display cases shall turn the lights on for up to 1 hour and shall automatically time out to turn the lights off.
 - 1.2. Motion sensor controls on each display case section that reduce lighting power by not less than 50 percent within 3 minutes after the area within the sensor range is vacated.
2. Low-temperature display cases shall incorporate temperature-based defrost termination control with a time-limit default. The defrost cycle shall terminate first on an upper temperature limit breach and second upon a time limit breach.
3. Antisweat heater controls shall reduce the energy use of the antisweat heater as a function of the relative humidity in the air outside the door or to the condensation on the inner glass pane.

C403.10.4 Refrigeration systems. Refrigerated display cases, *walk-in coolers* or *walk-in freezers* that are served by remote compressors and remote condensers not located in a condensing unit, shall comply with Sections C403.10.4.1 and C403.10.4.2.

Exception: Systems where the working fluid in the refrigeration cycle goes through both subcritical and super-critical states (transcritical) or that use ammonia refrigerant are exempt.

TABLE C403.10.2.1(1)
WALK-IN COOLER AND FREEZER DISPLAY DOOR EFFICIENCY REQUIREMENTS^a

CLASS DESCRIPTOR	CLASS	MAXIMUM ENERGY CONSUMPTION (kWh/day) ^a
Display door, medium temperature	DD, M	$0.04 \times A_{dd} + 0.41$
Display door, low temperature	DD, L	$0.15 \times A_{dd} + 0.29$

a. A_{dd} is the surface area of the display door.

TABLE C403.10.2.1(2)
WALK-IN COOLER AND FREEZER NONDISPLAY DOOR EFFICIENCY REQUIREMENTS^a

CLASS DESCRIPTOR	CLASS	MAXIMUM ENERGY CONSUMPTION (kWh/day) ^a
Passage door, medium temperature	PD, M	$0.05 \times A_{nd} + 1.7$
Passage door, low temperature	PD, L	$0.14 \times A_{nd} + 4.8$
Freight door, medium temperature	FD, M	$0.04 \times A_{nd} + 1.9$
Freight door, low temperature	FD, L	$0.12 \times A_{nd} + 5.6$

a. A_{nd} is the surface area of the nondisplay door.

TABLE C403.10.2.1(3)
WALK-IN COOLER AND FREEZER REFRIGERATION SYSTEM EFFICIENCY REQUIREMENTS

CLASS DESCRIPTOR	CLASS	MINIMUM ANNUAL WALK-IN ENERGY FACTOR AWEF (Btu/W-h)
Dedicated condensing, medium temperature, indoor system	DC.M.I	5.61
Dedicated condensing, medium temperature, indoor system, > 9,000 Btu/h capacity	DC.M.I, > 9,000	5.61
Dedicated condensing, medium temperature, outdoor system	DC.M.I	7.60
Dedicated condensing, medium temperature, outdoor system, > 9,000 Btu/h capacity	DC.M.I, > 9,000	7.60

tic-plus-embedded-fabric systems or tapes installed in accordance with the manufacturer’s instructions. Pressure classifications specific to the duct system shall be clearly indicated on the construction documents in accordance with the *International Mechanical Code*.

Exception: Locking-type longitudinal joints and seams, other than the snap-lock and button-lock types, need not be sealed as specified in this section.

C403.11.2.2 Medium-pressure duct systems (Mandatory). Ducts and plenums designed to operate at a static pressure greater than 2 inches water gauge (w.g.) (498 Pa) but less than 3 inches w.g. (747 Pa) shall be insulated and sealed in accordance with Section C403.11.1. Pressure classifications specific to the duct system shall be clearly indicated on the construction documents in accordance with the *International Mechanical Code*.

C403.11.2.3 High-pressure duct systems (Mandatory). Ducts and plenums designed to operate at static pressures equal to or greater than 3 inches water gauge (747 Pa) shall be insulated and sealed in accordance with Section C403.11.1. In addition, ducts and plenums shall be leak tested in accordance with the SMACNA HVAC Air Duct Leakage Test Manual and shown to have a rate of air leakage (CL) less than or equal to 4.0 as determined in accordance with Equation 4-8.

$$CL = F/P^{0.65} \quad \text{(Equation 4-8)}$$

where:

F = The measured leakage rate in cfm per 100 square feet of duct surface.

P = The static pressure of the test.

Documentation shall be furnished by the designer demonstrating that representative sections totaling not less than 25 percent of the duct area have been tested and that all tested sections comply with the requirements of this section.

C403.11.3 Piping insulation (Mandatory). Piping serving as part of a heating or cooling system shall be thermally insulated in accordance with Table C403.11.3.

Exceptions:

1. Factory-installed piping within HVAC equipment tested and rated in accordance with a test procedure referenced by this code.
2. Factory-installed piping within room fan-coils and unit ventilators tested and rated according to AHRI 440 (except that the sampling and variation provisions of Section 6.5 shall not apply) and AHRI 840, respectively.
3. Piping that conveys fluids that have a design operating temperature range between 60°F (15°C) and 105°F (41°C).
4. Piping that conveys fluids that have not been heated or cooled through the use of fossil fuels or electric power.
5. Strainers, control valves, and balancing valves associated with piping 1 inch (25 mm) or less in diameter.
6. Direct buried piping that conveys fluids at or below 60°F (15°C).

C403.11.3.1 Protection of piping insulation (Mandatory). Piping insulation exposed to the weather shall be protected from damage, including that caused by sun-

TABLE C403.11.3
MINIMUM PIPE INSULATION THICKNESS (in inches)^{a, c}

FLUID OPERATING TEMPERATURE RANGE AND USAGE (°F)	INSULATION CONDUCTIVITY		NOMINAL PIPE OR TUBE SIZE (inches)				
	Conductivity Btu • in./h • ft ² • °F ^b	Mean Rating Temperature, °F	< 1	1 to < 1½	1½ to < 4	4 to < 8	≥ 8
> 350	0.32 – 0.34	250	4.5	5.0	5.0	5.0	5.0
251 – 350	0.29 – 0.32	200	3.0	4.0	4.5	4.5	4.5
201 – 250	0.27 – 0.30	150	2.5	2.5	2.5	3.0	3.0
141 – 200	0.25 – 0.29	125	1.5	1.5	2.0	2.0	2.0
105 – 140	0.21 – 0.28	100	1.0	1.0	1.5	1.5	1.5
40 – 60	0.21 – 0.27	75	0.5	0.5	1.0	1.0	1.0
< 40	0.20 – 0.26	50	0.5	1.0	1.0	1.0	1.5

For SI: 1 inch = 25.4 mm, °C = [(°F) - 32]/1.8.

a. For piping smaller than 1½ inches and located in partitions within conditioned spaces, reduction of these thicknesses by 1 inch shall be permitted (before thickness adjustment required in footnote b) but not to a thickness less than 1 inch.

b. For insulation outside the stated conductivity range, the minimum thickness (T) shall be determined as follows:

$$T = r [(1 + t/r)^{k/k} - 1]$$

where:

T = minimum insulation thickness,

r = actual outside radius of pipe,

t = insulation thickness listed in the table for applicable fluid temperature and pipe size,

K = conductivity of alternate material at mean rating temperature indicated for the applicable fluid temperature (Btu • in/h • ft² • °F) and

k = the upper value of the conductivity range listed in the table for the applicable fluid temperature.

c. For direct-buried heating and hot water system piping, reduction of these thicknesses by 1½ inches (38 mm) shall be permitted (before thickness adjustment required in footnote b but not to thicknesses less than 1 inch).

light, moisture, equipment maintenance and wind, and shall provide shielding from solar radiation that can cause degradation of the material. Adhesive tape shall not be permitted.

C403.12 Mechanical systems located outside of the building thermal envelope (Mandatory). Mechanical systems providing heat outside of the thermal envelope of a building shall comply with Sections C403.12.1 through C403.12.3.

C403.12.1 Heating outside a building. Systems installed to provide heat outside a building shall be radiant systems.

Such heating systems shall be controlled by an occupancy sensing device or a timer switch, so that the system is automatically de-energized when occupants are not present.

C403.12.2 Snow- and ice-melt system controls. Snow- and ice-melting systems shall include automatic controls configured to shut off the system when the pavement temperature is above 50°F (10°C) and precipitation is not falling, and an automatic or manual control that is configured to shut off when the outdoor temperature is above 40°F (4°C).

C403.12.3 Freeze protection system controls. Freeze protection systems, such as heat tracing of outdoor piping and heat exchangers, including self-regulating heat tracing, shall include automatic controls configured to shut off the systems when outdoor air temperatures are above 40°F (4°C) or when the conditions of the protected fluid will prevent freezing.

SECTION C404

SERVICE WATER HEATING (MANDATORY)

C404.1 General. This section covers the minimum efficiency of, and controls for, service water-heating equipment and insulation of service hot water piping.

C404.2 Service water-heating equipment performance efficiency. Water-heating equipment and hot water storage tanks shall meet the requirements of Table C404.2. The efficiency shall be verified through data furnished by the manufacturer of the equipment or through certification under an *approved* certification program. Water-heating equipment intended to be used to provide space heating shall meet the applicable provisions of Table C404.2.

C404.2.1 High input service water-heating systems. Gas-fired water-heating equipment installed in new buildings shall be in compliance with this section. Where a singular piece of water-heating equipment serves the entire building and the input rating of the equipment is 1,000,000 Btu/h (293 kW) or greater, such equipment shall have a thermal efficiency, E_p , of not less than 90 percent. Where multiple pieces of water-heating equipment serve the building and the combined input rating of the water-heating equipment is 1,000,000 Btu/h (293 kW) or greater, the combined input-capacity-weighted-average thermal efficiency, E_p , shall be not less than 90 percent.

Exceptions:

1. Where not less than 25 percent of the annual *service water-heating* requirement is provided by *on-*

site renewable energy or site-recovered energy, the minimum thermal efficiency requirements of this section shall not apply.

2. The input rating of water heaters installed in individual dwelling units shall not be required to be included in the total input rating of *service water-heating* equipment for a building.
3. The input rating of water heaters with an input rating of not greater than 100,000 Btu/h (29.3 kW) shall not be required to be included in the total input rating of *service water-heating* equipment for a building.

C404.3 Heat traps for hot water storage tanks. Storage tank-type water heaters and hot water storage tanks that have vertical water pipes connecting to the inlet and outlet of the tank shall be provided with integral heat traps at those inlets and outlets or shall have pipe-configured heat traps in the piping connected to those inlets and outlets. Tank inlets and outlets associated with solar water heating system circulation loops shall not be required to have heat traps.

C404.4 Insulation of piping. Piping from a water heater to the termination of the heated water fixture supply pipe shall be insulated in accordance with Table C403.11.3. On both the inlet and outlet piping of a storage water heater or heated water storage tank, the piping to a heat trap or the first 8 feet (2438 mm) of piping, whichever is less, shall be insulated. Piping that is heat traced shall be insulated in accordance with Table C403.11.3 or the heat trace manufacturer's instructions. Tubular pipe insulation shall be installed in accordance with the insulation manufacturer's instructions. Pipe insulation shall be continuous except where the piping passes through a framing member. The minimum insulation thickness requirements of this section shall not supersede any greater insulation thickness requirements necessary for the protection of piping from freezing temperatures or the protection of personnel against external surface temperatures on the insulation.

Exception: Tubular pipe insulation shall not be required on the following:

1. The tubing from the connection at the termination of the fixture supply piping to a plumbing fixture or plumbing appliance.
2. Valves, pumps, strainers and threaded unions in piping that is 1 inch (25 mm) or less in nominal diameter.
3. Piping from user-controlled shower and bath mixing valves to the water outlets.
4. Cold-water piping of a demand recirculation water system.
5. Tubing from a hot drinking-water heating unit to the water outlet.
6. Piping at locations where a vertical support of the piping is installed.
7. Piping surrounded by building insulation with a thermal resistance (R -value) of not less than R-3.

C404.5 Heated water supply piping. Heated water supply piping shall be in accordance with Section C404.5.1 or C404.5.2. The flow rate through 1/4-inch (6.4 mm) piping shall be not greater than 0.5 gpm (1.9 L/m). The flow rate

**TABLE C404.2
MINIMUM PERFORMANCE OF WATER-HEATING EQUIPMENT**

EQUIPMENT TYPE	SIZE CATEGORY (input)	SUBCATEGORY OR RATING CONDITION	PERFORMANCE REQUIRED ^{a, b}	TEST PROCEDURE
Water heaters, electric	≤ 12 kW ^d	Tabletop ^e , ≥ 20 gallons and ≤ 120 gallons	0.93 - 0.00132V, EF	DOE 10 CFR Part 430
		Resistance ≥ 20 gallons and ≤ 55 gallons	0.960 - 0.0003V, EF	
		Grid-enabled ^f > 75 gallons and ≤ 120 gallons	1.061 - 0.00168V, EF	
	> 12 kW	Resistance	(0.3 + 27/V _m), %/h	ANSI Z21.10.3
	≤ 24 amps and ≤ 250 volts	Heat pump > 55 gallons and ≤ 120 gallons	2.057 - 0.00113V, EF	DOE 10 CFR Part 430
Storage water heaters, gas	≤ 75,000 Btu/h	≥ 20 gallons and ≤ 55 gallons	0.675 - 0.0015V, EF	DOE 10 CFR Part 430
		> 55 gallons and ≤ 100 gallons	0.8012 - 0.00078V, EF	
	> 75,000 Btu/h and ≤ 155,000 Btu/h	< 4,000 Btu/h/gal	80% E _t (Q/800 + 110√V)SL, Btu/h	ANSI Z21.10.3
> 155,000 Btu/h	< 4,000 Btu/h/gal	80% E _t (Q/800 + 110√V)SL, Btu/h		
Instantaneous water heaters, gas	> 50,000 Btu/h and < 200,000 Btu/h ^c	≥ 4,000 (Btu/h)/gal and < 2 gal	0.82 - 0.0019V, EF	DOE 10 CFR Part 430
	≥ 200,000 Btu/h	≥ 4,000 Btu/h/gal and < 10 gal	80% E _t	ANSI Z21.10.3
	≥ 200,000 Btu/h	≥ 4,000 Btu/h/gal and ≥ 10 gal	80% E _t (Q/800 + 110√V)SL, Btu/h	
Storage water heaters, oil	≤ 105,000 Btu/h	≥ 20 gal and ≤ 50 gallons	0.68 - 0.0019V, EF	DOE 10 CFR Part 430
	≥ 105,000 Btu/h	< 4,000 Btu/h/gal	80% E _t (Q/800 + 110√V)SL, Btu/h	ANSI Z21.10.3
Instantaneous water heaters, oil	≤ 210,000 Btu/h	≥ 4,000 Btu/h/gal and < 2 gal	0.59 - 0.0019V, EF	DOE 10 CFR Part 430
	> 210,000 Btu/h	≥ 4,000 Btu/h/gal and < 10 gal	80% E _t	ANSI Z21.10.3
	> 210,000 Btu/h	≥ 4,000 Btu/h/gal and ≥ 10 gal	78% E _t (Q/800 + 110√V)SL, Btu/h	
Hot water supply boilers, gas and oil	≥ 300,000 Btu/h and < 12,500,000 Btu/h	≥ 4,000 Btu/h/gal and < 10 gal	80% E _t	ANSI Z21.10.3
Hot water supply boilers, gas	≥ 300,000 Btu/h and < 12,500,000 Btu/h	≥ 4,000 Btu/h/gal and ≥ 10 gal	80% E _t (Q/800 + 110√V)SL, Btu/h	
Hot water supply boilers, oil	> 300,000 Btu/h and < 12,500,000 Btu/h	> 4,000 Btu/h/gal and > 10 gal	78% E _t (Q/800 + 110√V)SL, Btu/h	
Pool heaters, gas and oil	All	—	82% E _t	ASHRAE 146

(continued)

TABLE C404.2—continued
MINIMUM PERFORMANCE OF WATER-HEATING EQUIPMENT

EQUIPMENT TYPE	SIZE CATEGORY (input)	SUBCATEGORY OR RATING CONDITION	PERFORMANCE REQUIRED ^{a, b}	TEST PROCEDURE
Heat pump pool heaters	All	—	4.0 COP	AHRI 1160
Unfired storage tanks	All	—	Minimum insulation requirement R-12.5 (h • ft ² • °F)/Btu	(none)

For SI: 1 foot = 304.8 mm, 1 square foot = 0.0929 m², °C = [(°F) - 32]/1.8, 1 British thermal unit per hour = 0.2931 W, 1 gallon = 3.785 L, 1 British thermal unit per hour per gallon = 0.078 W/L.

- a. Energy factor (EF) and thermal efficiency (*E_t*) are minimum requirements. In the EF equation, *V* is the rated volume in gallons.
- b. Standby loss (SL) is the maximum Btu/h based on a nominal 70°F temperature difference between stored water and ambient requirements. In the SL equation, *Q* is the nameplate input rate in Btu/h. In the equations for electric water heaters, *V* is the rated volume in gallons and *V_m* is the measured volume in gallons. In the SL equation for oil and gas water heaters and boilers, *V* is the rated volume in gallons.
- c. Instantaneous water heaters with input rates below 200,000 Btu/h shall comply with these requirements where the water heater is designed to heat water to temperatures 180°F or higher.
- d. Electric water heaters with an input rating of 12 kW (40,950 Btu/hr) or less that are designed to heat water to temperatures of 180°F or greater shall comply with the requirements for electric water heaters that have an input rating greater than 12 kW (40,950 Btu/h).
- e. A tabletop water heater is a water heater that is enclosed in a rectangular cabinet with a flat top surface not more than 3 feet in height.
- f. A grid-enabled water heater is an electric resistance water heater that meets all of the following:
 - 1. Has a rated storage tank volume of more than 75 gallons.
 - 2. Was manufactured on or after April 16, 2015.
 - 3. Is equipped at the point of manufacture with an activation lock.
 - 4. Bears a permanent label applied by the manufacturer that complies with all of the following:
 - 4.1. Is made of material not adversely affected by water.
 - 4.2. Is attached by means of nonwater-soluble adhesive.
 - 4.3. Advises purchasers and end users of the intended and appropriate use of the product with the following notice printed in 16.5 point Arial Narrow Bold font: "IMPORTANT INFORMATION: This water heater is intended only for use as part of an electric thermal storage or demand response program. It will not provide adequate hot water unless enrolled in such a program and activated by your utility company or another program operator. Confirm the availability of a program in your local area before purchasing or installing this product."

through ⁵/₁₆-inch (7.9 mm) piping shall be not greater than 1 gpm (3.8 L/m). The flow rate through ³/₈-inch (9.5 mm) piping shall be not greater than 1.5 gpm (5.7 L/m).

C404.5.1 Maximum allowable pipe length method. The maximum allowable piping length from the nearest source of heated water to the termination of the fixture supply pipe shall be in accordance with the following. Where the piping contains more than one size of pipe, the largest size of pipe within the piping shall be used for determining the maximum allowable length of the piping in Table C404.5.1.

- 1. For a public lavatory faucet, use the "Public lavatory faucets" column in Table C404.5.1.
- 2. For all other plumbing fixtures and plumbing appliances, use the "Other fixtures and appliances" column in Table C404.5.1.

C404.5.2 Maximum allowable pipe volume method. The water volume in the piping shall be calculated in accordance with Section C404.5.2.1. Water heaters, circulating water systems and heat trace temperature maintenance systems shall be considered to be sources of heated water.

The volume from the nearest source of heated water to the termination of the fixture supply pipe shall be as follows:

- 1. For a public lavatory faucet: not more than 2 ounces (0.06 L).
- 2. For other plumbing fixtures or plumbing appliances; not more than 0.5 gallon (1.89 L).

C404.5.2.1 Water volume determination. The volume shall be the sum of the internal volumes of pipe, fittings, valves, meters and manifolds between the nearest source of heated water and the termination of the fixture supply pipe. The volume in the piping shall be determined from the "Volume" column in Table C404.5.1. The volume contained within fixture shutoff valves, within flexible water supply connectors to a fixture fitting and within a fixture fitting shall not be included in the water volume determination. Where heated water is supplied by a recirculating system or heat-traced piping, the volume shall include the portion of the fitting on the branch pipe that supplies water to the fixture.

C404.6 Heated-water circulating and temperature maintenance systems. Heated-water circulation systems shall be in accordance with Section C404.6.1. Heat trace temperature maintenance systems shall be in accordance with Section C404.6.2. Controls for hot water storage shall be in accordance with Section C404.6.3. Automatic controls, temperature sensors and pumps shall be in a location with *access*. Manual controls shall be in a location with *ready access*.

C404.6.1 Circulation systems. Heated-water circulation systems shall be provided with a circulation pump. The system return pipe shall be a dedicated return pipe or a cold water supply pipe. Gravity and thermo-siphon circulation systems shall be prohibited. Controls for circulating hot water system pumps shall start the pump based on the identification of a demand for hot water within the occupancy. The controls shall automatically turn off the pump

**TABLE C404.5.1
PIPING VOLUME AND MAXIMUM PIPING LENGTHS**

NOMINAL PIPE SIZE (inches)	VOLUME (liquid ounces per foot length)	MAXIMUM PIPING LENGTH (feet)	
		Public lavatory faucets	Other fixtures and appliances
1/4	0.33	6	50
5/16	0.5	4	50
3/8	0.75	3	50
1/2	1.5	2	43
5/8	2	1	32
3/4	3	0.5	21
7/8	4	0.5	16
1	5	0.5	13
1 1/4	8	0.5	8
1 1/2	11	0.5	6
2 or larger	18	0.5	4

For SI: 1 inch = 25.4 mm, 1 foot = 304.8 mm, 1 liquid ounce = 0.030 L, 1 gallon = 128 ounces.

when the water in the circulation loop is at the desired temperature and when there is not a demand for hot water.

C404.6.2 Heat trace systems. Electric heat trace systems shall comply with IEEE 515.1. Controls for such systems shall be able to automatically adjust the energy input to the heat tracing to maintain the desired water temperature in the piping in accordance with the times when heated water is used in the occupancy. Heat trace shall be arranged to be turned off automatically when there is not a demand for hot water.

C404.6.3 Controls for hot water storage. The controls on pumps that circulate water between a water heater and a heated-water storage tank shall limit operation of the pump from heating cycle startup to not greater than 5 minutes after the end of the cycle.

C404.7 Demand recirculation controls. Demand recirculation water systems shall have controls that comply with both of the following:

1. The controls shall start the pump upon receiving a signal from the action of a user of a fixture or appliance, sensing the presence of a user of a fixture or sensing the flow of hot or tempered water to a fixture fitting or appliance.
2. The controls shall limit the temperature of the water entering the cold-water piping to not greater than 104°F (40°C).

C404.8 Drain water heat recovery units. Drain water heat recovery units shall comply with CSA B55.2. Potable water-side pressure loss shall be less than 10 psi (69 kPa) at maximum design flow. For *Group R* occupancies, the efficiency of drain water heat recovery unit efficiency shall be in accordance with CSA B55.1.

C404.9 Energy consumption of pools and permanent spas (Mandatory). The energy consumption of pools and permanent

spas shall be controlled by the requirements in Sections C404.9.1 through C404.9.3.

C404.9.1 Heaters. The electric power to all heaters shall be controlled by an on-off switch that is an integral part of the heater, mounted on the exterior of the heater, or external to and within 3 feet (914 mm) of the heater in a location with *ready access*. Operation of such switch shall not change the setting of the heater thermostat. Such switches shall be in addition to a circuit breaker for the power to the heater. Gas-fired heaters shall not be equipped with continuously burning ignition pilots.

C404.9.2 Time switches. Time switches or other control methods that can automatically turn off and on heaters and pump motors according to a preset schedule shall be installed for heaters and pump motors. Heaters and pump motors that have built-in time switches shall be in compliance with this section.

Exceptions:

1. Where public health standards require 24-hour pump operation.
2. Pumps that operate solar- and waste-heat-recovery pool heating systems.

C404.9.3 Covers. Outdoor heated pools and outdoor permanent spas shall be provided with a vapor-retardant cover or other *approved* vapor-retardant means.

Exception: Where more than 75 percent of the energy for heating, computed over an operating season of not fewer than 3 calendar months, is from site-recovered energy such as from a heat pump or on-site renewable energy system, covers or other vapor-retardant means shall not be required.

C404.10 Energy consumption of portable spas (Mandatory). The energy consumption of electric-powered portable spas shall be controlled by the requirements of APSP 14.

SECTION C405 ELECTRICAL POWER AND LIGHTING SYSTEMS

C405.1 General (Mandatory). This section covers lighting system controls, the maximum lighting power for interior and exterior applications and electrical energy consumption.

Dwelling units within multifamily buildings shall comply with Section R404.1. All other *dwelling units* shall comply with Section R404.1, or with Sections C405.2.4 and C405.3. *Sleeping units* shall comply with Section C405.2.4, and with Section R404.1 or C405.3. Lighting installed in walk-in coolers, walk-in freezers, refrigerated warehouse coolers and refrigerated warehouse freezers shall comply with the lighting requirements of Section C403.10.1 or C403.10.2.

C405.2 Lighting controls (Mandatory). Lighting systems shall be provided with controls that comply with one of the following.

1. Lighting controls as specified in Sections C405.2.1 through C405.2.6.
2. Luminaire level lighting controls (LLLC) and lighting controls as specified in Sections C405.2.1, C405.2.4 and C405.2.5. The LLLC luminaire shall be independently capable of:
 - 2.1. Monitoring occupant activity to brighten or dim lighting when occupied or unoccupied, respectively.
 - 2.2. Monitoring ambient light, both electric light and daylight, and brighten or dim artificial light to maintain desired light level.
 - 2.3. For each control strategy, configuration and reconfiguration of performance parameters including; bright and dim setpoints, timeouts, dimming fade rates, sensor sensitivity adjustments, and wireless zoning configurations.

Exceptions: Lighting controls are not required for the following:

1. Areas designated as security or emergency areas that are required to be continuously lighted.
2. Interior exit stairways, interior exit ramps and exit passageways.
3. Emergency egress lighting that is normally off.

C405.2.1 Occupant sensor controls. Occupant *sensor controls* shall be installed to control lights in the following space types:

1. Classrooms/lecture/training rooms.
2. Conference/meeting/multipurpose rooms.
3. Copy/print rooms.
4. Lounges/breakrooms.
5. Enclosed offices.
6. Open plan office areas.
7. Restrooms.
8. Storage rooms.
9. Locker rooms.
10. Other spaces 300 square feet (28 m²) or less that are enclosed by floor-to-ceiling height partitions.
11. Warehouse storage areas.

C405.2.1.1 Occupant sensor control function. Occupant sensor controls in warehouses shall comply with Section C405.2.1.2. Occupant sensor controls in open plan office areas shall comply with Section C405.2.1.3. Occupant sensor controls for all other spaces specified in Section C405.2.1 shall comply with the following:

1. They shall automatically turn off lights within 20 minutes after all occupants have left the space.
2. They shall be manual on or controlled to automatically turn on the lighting to not more than 50-percent power.

Exception: Full automatic-on controls shall be permitted to control lighting in public corridors, stairways, restrooms, primary building entrance areas and lobbies, and areas where manual-on operation would endanger the safety or security of the room or building occupants.

3. They shall incorporate a manual control to allow occupants to turn off lights.

C405.2.1.2 Occupant sensor control function in warehouses. In warehouses, the lighting in aiseways and open areas shall be controlled with occupant sensors that automatically reduce lighting power by not less than 50 percent when the areas are unoccupied. The occupant sensors shall control lighting in each aisleway independently and shall not control lighting beyond the aisleway being controlled by the sensor.

C405.2.1.3 Occupant sensor control function in open plan office areas. Occupant sensor controls in open plan office spaces less than 300 square feet (28 m²) in area shall comply with Section C405.2.1.1. Occupant sensor controls in all other open plan office spaces shall comply with all of the following:

1. The controls shall be configured so that general lighting can be controlled separately in control zones with floor areas not greater than 600 square feet (55 m²) within the open plan office space.
2. The controls shall automatically turn off general lighting in all control zones within 20 minutes after all occupants have left the open plan office space.
3. The controls shall be configured so that general lighting power in each control zone is reduced by not less than 80 percent of the full zone general lighting power in a reasonably uniform illumination pattern within 20 minutes of all occupants leaving that control zone. Control functions that switch control zone lights completely off when the zone is vacant meet this requirement.
4. The controls shall be configured such that any daylight responsive control will activate open plan office space general lighting or control zone general lighting only when occupancy for the same area is detected.

C405.2.2 Time-switch controls. Each area of the building that is not provided with *occupant sensor controls* com-

plying with Section C405.2.1.1 shall be provided with *time-switch controls* complying with Section C405.2.2.1.

Exception: Where a *manual control* provides light reduction in accordance with Section C405.2.2.2, *time-switch controls* shall not be required for the following:

1. Spaces where patient care is directly provided.
2. Spaces where an automatic shutoff would endanger occupant safety or security.
3. Lighting intended for continuous operation.
4. Shop and laboratory classrooms.

C405.2.2.1 Time-switch control function. Each space provided with *time-switch controls* shall be provided with a *manual control* for light reduction in accordance with Section C405.2.2.2. *Time-switch controls* shall include an override switching device that complies with the following:

1. Have a minimum 7-day clock.
2. Be capable of being set for seven different day types per week.
3. Incorporate an automatic holiday “shutoff” feature, which turns off all controlled lighting loads for not fewer than 24 hours and then resumes normally scheduled operations.
4. Have program backup capabilities, which prevent the loss of program and time settings for not fewer than 10 hours, if power is interrupted.
5. Include an override switch that complies with the following:
 - 5.1. The override switch shall be a manual control.
 - 5.2. The override switch, when initiated, shall permit the controlled lighting to remain on for not more than 2 hours.
 - 5.3. Any individual override switch shall control the lighting for an area not larger than 5,000 square feet (465 m²).

Exceptions:

1. Within mall concourses, auditoriums, sales areas, manufacturing facilities and sports arenas:
 - 1.1. The time limit shall be permitted to be greater than 2 hours, provided that the switch is a captive key device.
 - 1.2. The area controlled by the override switch shall not be limited to 5,000 square feet (465 m²) provided that such area is less than 20,000 square feet (1860 m²).
2. Where provided with *manual control*, the following areas are not required to have light reduction control:
 - 2.1. Spaces that have only one luminaire with a rated power of less than 100 watts.

2.2. Spaces that use less than 0.6 watts per square foot (6.5 W/m²).

2.3. Corridors, lobbies, electrical rooms and or mechanical rooms.

C405.2.2.2 Light-reduction controls. Spaces required to have light-reduction controls shall have a *manual control* that allows the occupant to reduce the connected lighting load in a reasonably uniform illumination pattern by not less than 50 percent. Lighting reduction shall be achieved by one of the following or another *approved* method:

1. Controlling all lamps or luminaires.
2. Dual switching of alternate rows of luminaires, alternate luminaires or alternate lamps.
3. Switching the middle lamp luminaires independently of the outer lamps.
4. Switching each luminaire or each lamp.

Exception: Light reduction controls are not required in *daylight zones* with *daylight responsive controls* complying with Section C405.2.3.

C405.2.3 Daylight-responsive controls. *Daylight-responsive controls* complying with Section C405.2.3.1 shall be provided to control the electric lights within *daylight zones* in the following spaces:

1. Spaces with a total of more than 150 watts of *general lighting* within sidelit zones complying with Section C405.2.3.2 *General lighting* does not include lighting that is required to have specific application control in accordance with Section C405.2.4.
2. Spaces with a total of more than 150 watts of *general lighting* within toplit zones complying with Section C405.2.3.3.

Exceptions: Daylight responsive controls are not required for the following:

1. Spaces in health care facilities where patient care is directly provided.
2. Lighting that is required to have specific application control in accordance with Section C405.2.4.
3. Sidelit zones on the first floor above grade in Group A-2 and Group M occupancies.
4. New buildings where the total connected lighting power calculated in accordance with Section C405.3.1 is not greater than the adjusted interior lighting power allowance (LPA_{adj}) calculated in accordance with Equation 4-9:

$$LPA_{adj} = [LPA_{norm} \times (1.0 - 0.4 \times UDZFA / TBFA)]$$

(Equation 4-9)

where:

LPA_{adj} = Adjusted building interior lighting power allowance in watts.

LPA_{norm} = Normal building lighting power allowance in watts calculated in

permanently installed luminaires and switched receptacles within 20 minutes after all occupants have left the unit.

Exceptions:

1. Lighting and switched receptacles controlled by card key controls.
2. Spaces where patient care is directly provided.
3. Permanently installed luminaires within *dwelling units* shall be provided with controls complying with Section C405.2.1.1 or C405.2.2.2.
4. Lighting for nonvisual applications, such as plant growth and food warming, shall be controlled by a time switch control complying with Section C405.2.2.1 that is independent of the controls for other lighting within the room or space.

C405.2.5 Manual controls. Where required by this code, manual controls for lights shall comply with the following:

1. They shall be in a location with *ready access* to occupants.
2. They shall be located where the controlled lights are visible, or shall identify the area served by the lights and indicate their status.

C405.2.6 Exterior lighting controls. Exterior lighting systems shall be provided with controls that comply with Sections C405.2.6.1 through C405.2.6.4. Decorative lighting systems shall comply with Sections C405.2.6.1, C405.2.6.2 and C405.2.6.4.

Exceptions:

1. Lighting for covered vehicle entrances and exits from buildings and parking structures where required for eye adaptation.
2. Lighting controlled from within dwelling units.

C405.2.6.1 Daylight shutoff. Lights shall be automatically turned off when daylight is present and satisfies the lighting needs.

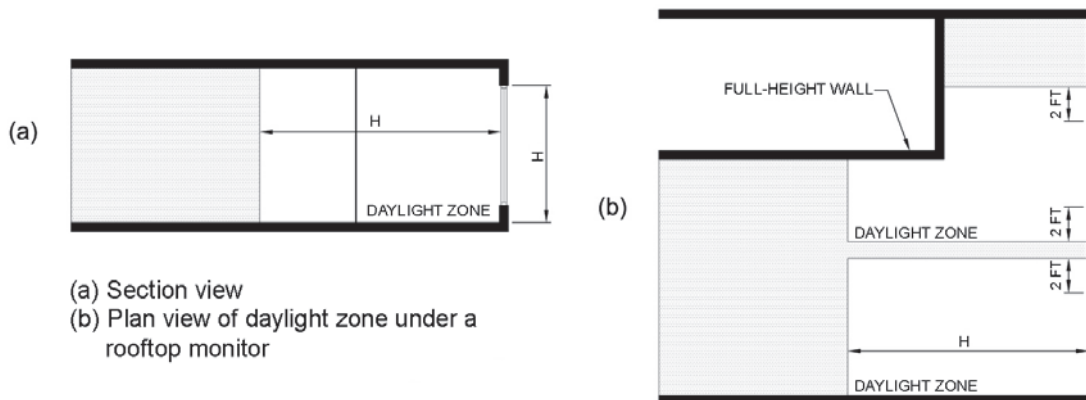

FIGURE C405.2.3.2 SIDELIT ZONE

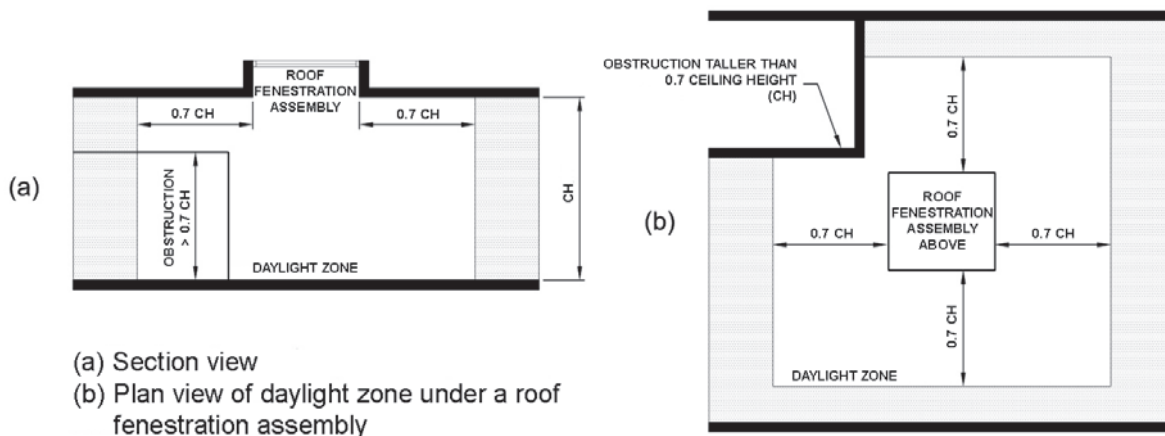

FIGURE C405.2.3.3(1) TOPLIT ZONE

C405.2.6.2 Decorative lighting shutoff. Building facade and landscape lighting shall automatically shut off from not later than 1 hour after business closing to not earlier than 1 hour before business opening.

C405.2.6.3 Lighting setback. Lighting that is not controlled in accordance with Section C405.2.6.2 shall be controlled so that the total wattage of such lighting is automatically reduced by not less than 30 percent by selectively switching off or dimming luminaires at one of the following times:

1. From not later than midnight to not earlier than 6 a.m.
2. From not later than one hour after business closing to not earlier than one hour before business opening.
3. During any time where activity has not been detected for 15 minutes or more.

C405.2.6.4 Exterior time-switch control function. Time-switch controls for exterior lighting shall comply with the following:

1. They shall have a clock capable of being programmed for not fewer than 7 days.
2. They shall be capable of being set for seven different day types per week.
3. They shall incorporate an automatic holiday setback feature.
4. They shall have program backup capabilities that prevent the loss of program and time settings for a period of not less than 10 hours in the event that power is interrupted.

C405.3 Interior lighting power requirements (Prescriptive). A building complies with this section where its total connected interior lighting power calculated under Section

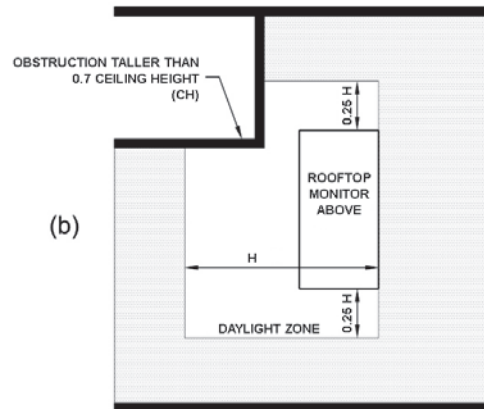
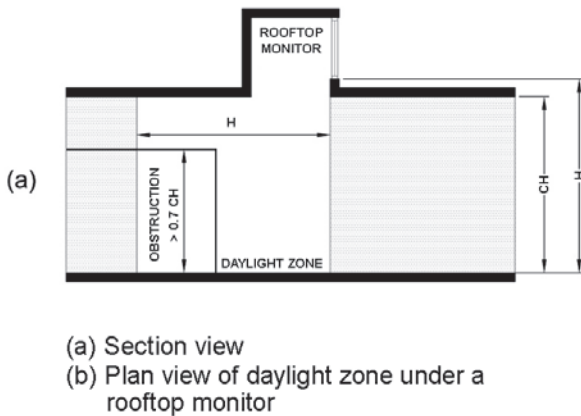

FIGURE C405.2.3.3(2)
DAYLIGHT ZONE UNDER A ROOFTOP MONITOR

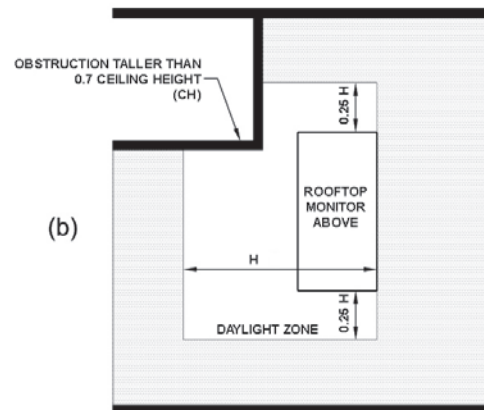
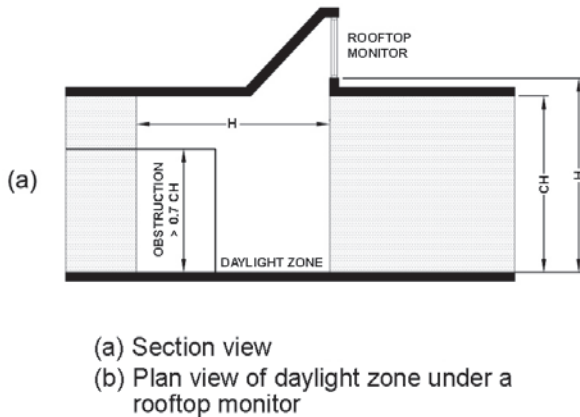

FIGURE C405.2.3.3(3)
DAYLIGHT ZONE UNDER A SLOPED ROOFTOP MONITOR

C405.3.1 is not greater than the interior lighting power allowance calculated under Section C405.3.2.

C405.3.1 Total connected interior lighting power. The total connected interior lighting power shall be determined in accordance with Equation 4-10.

$$TCLP = [LVL + BLL + LED + TRK + \text{Other}] \quad \text{(Equation 4-10)}$$

where:

TCLP = Total connected lighting power (watts).

LVL = For luminaires with lamps connected directly to building power, such as line voltage lamps, the rated wattage of the lamp.

BLL = For luminaires incorporating a ballast or transformer, the rated input wattage of the ballast or transformer when operating that lamp.

LED = For light-emitting diode luminaires with either integral or remote drivers, the rated wattage of the luminaire.

TRK = For lighting track, cable conductor, rail conductor, and plug-in busway systems that allow the addition and relocation of luminaires without rewiring, the wattage shall be one of the following:

1. The specified wattage of the luminaires, but not less than 8 W per linear foot (25 W/lin m).
2. The wattage limit of the permanent current-limiting devices protecting the system.
3. The wattage limit of the transformer supplying the system.

Other = The wattage of all other luminaires and lighting sources not covered previously and associated with interior lighting verified by data supplied by the manufacturer or other *approved* sources.

The connected power associated with the following lighting equipment and applications is not included in calculating total connected lighting power.

1. Television broadcast lighting for playing areas in sports arenas.
2. Emergency lighting automatically off during normal building operation.
3. Lighting in spaces specifically designed for use by occupants with special lighting needs, including those with visual impairment and other medical and age-related issues.
4. Casino gaming areas.
5. Mirror lighting in dressing rooms.
6. Task lighting for medical and dental purposes that is in addition to general lighting and controlled by an independent control device.
7. Display lighting for exhibits in galleries, museums and monuments that is in addition to general lighting and controlled by an independent control device.

8. Lighting for theatrical purposes, including performance, stage, film production and video production.
9. Lighting for photographic processes.
10. Lighting integral to equipment or instrumentation and installed by the manufacturer.
11. Task lighting for plant growth or maintenance.
12. Advertising signage or directional signage.
13. Lighting for food warming.
14. Lighting equipment that is for sale.
15. Lighting demonstration equipment in lighting education facilities.
16. Lighting approved because of safety considerations.
17. Lighting in retail display windows, provided that the display area is enclosed by ceiling-height partitions.
18. Furniture-mounted supplemental task lighting that is controlled by automatic shutoff.
19. Exit signs.

C405.3.2 Interior lighting power allowance. The total interior lighting power allowance (watts) is determined according to Table C405.3.2(1) using the Building Area Method, or Table C405.3.2(2) using the Space-by-Space Method, for all areas of the building covered in this permit.

C405.3.2.1 Building Area Method. For the Building Area Method, the interior lighting power allowance is the floor area for each building area type listed in Table C405.3.2(1) times the value from Table C405.3.2(1) for that area. For the purposes of this method, an “area” shall be defined as all contiguous spaces that accommodate or are associated with a single building area type, as listed in Table C405.3.2(1). Where this method is used to calculate the total interior lighting power for an entire building, each building area type shall be treated as a separate area.

C405.3.2.2 Space-by-Space Method. For the Space-by-Space Method, the interior lighting power allowance is determined by multiplying the floor area of each space times the value for the space type in Table C405.3.2(2) that most closely represents the proposed use of the space, and then summing the lighting power allowances for all spaces. Tradeoffs among spaces are permitted.

C405.3.2.2.1 Additional interior lighting power. Where using the Space-by-Space Method, an increase in the interior lighting power allowance is permitted for specific lighting functions. Additional power shall be permitted only where the specified lighting is installed and automatically controlled separately from the general lighting, to be turned off during nonbusiness hours. This additional power shall be used only for the specified luminaires and shall not be used for any other purpose. An increase

TABLE C405.3.2(1)
INTERIOR LIGHTING POWER ALLOWANCES:
BUILDING AREA METHOD

BUILDING AREA TYPE	LPD (w/ft ²)
Automotive facility	0.71
Convention center	0.76
Courthouse	0.90
Dining: bar lounge/leisure	0.90
Dining: cafeteria/fast food	0.79
Dining: family	0.78
Dormitory ^{a, b}	0.61
Exercise center	0.65
Fire station ^a	0.53
Gymnasium	0.68
Health care clinic	0.82
Hospital ^a	1.05
Hotel/Motel ^{a, b}	0.75
Library	0.78
Manufacturing facility	0.90
Motion picture theater	0.83
Multifamily ^c	0.68
Museum	1.06
Office	0.79
Parking garage	0.15
Penitentiary	0.75
Performing arts theater	1.18
Police station	0.80
Post office	0.67
Religious building	0.94
Retail	1.06
School/university	0.81
Sports arena	0.87
Town hall	0.80
Transportation	0.61
Warehouse	0.48
Workshop	0.90

- a. Where sleeping units are excluded from lighting power calculations by application of Section R405.1, neither the area of the sleeping units nor the wattage of lighting in the sleeping units is counted.
- b. Where dwelling units are excluded from lighting power calculations by application of Section R405.1, neither the area of the dwelling units nor the wattage of lighting in the dwelling units is counted.
- c. Dwelling units are excluded. Neither the area of the dwelling units nor the wattage of lighting in the dwelling units is counted.

TABLE C405.3.2(2)
INTERIOR LIGHTING POWER ALLOWANCES:
SPACE-BY-SPACE METHOD

COMMON SPACE TYPES ^a	LPD (watts/sq.ft)
Atrium	
Less than 40 feet in height	0.03 per foot in total height
Greater than 40 feet in height	0.40 + 0.02 per foot in total height
Audience seating area	
In an auditorium	0.63
In a convention center	0.82
In a gymnasium	0.65
In a motion picture theater	1.14
In a penitentiary	0.28
In a performing arts theater	2.03
In a religious building	1.53
In a sports arena	0.43
Otherwise	0.43
Banking activity area	
Breakroom (See Lounge/breakroom)	
Classroom/lecture hall/training room	
In a penitentiary	1.34
Otherwise	0.96
Computer room	
Conference/meeting/multipurpose room	
Copy/print room	
Corridor	
In a facility for the visually impaired (and not used primarily by the staff) ^b	0.92
In a hospital	0.92
In a manufacturing facility	0.29
Otherwise	0.66
Courtroom	
Dining area	
In bar/lounge or leisure dining	0.93
In cafeteria or fast food dining	0.63
In a facility for the visually impaired (and not used primarily by the staff) ^b	2.00
In family dining	0.71
In a penitentiary	0.96
Otherwise	0.63
Electrical/mechanical room	
Emergency vehicle garage	

(continued)

**TABLE C405.3.2(2)—continued
INTERIOR LIGHTING POWER ALLOWANCES:
SPACE-BY-SPACE METHOD**

COMMON SPACE TYPES ^a	LPD (watts/sq.ft)
Food preparation area	1.06
Guestroom ^{c, d}	0.77
Laboratory	
In or as a classroom	1.20
Otherwise	1.45
Laundry/washing area	0.43
Loading dock, interior	0.58
Lobby	
For an elevator	0.68
In a facility for the visually impaired (and not used primarily by the staff) ^b	2.03
In a hotel	1.06
In a motion picture theater	0.45
In a performing arts theater	1.70
Otherwise	1.0
Locker room	0.48
Lounge/breakroom	
In a healthcare facility	0.78
Otherwise	0.62
Office	
Enclosed	0.93
Open plan	0.81
Parking area, interior	0.14
Pharmacy area	1.34
Restroom	
In a facility for the visually impaired (and not used primarily by the staff) ^b	0.96
Otherwise	0.85
Sales area	1.22
Seating area, general	0.42
Stairway (see Space containing stairway)	
Stairwell	0.58
Storage room	0.46
Vehicular maintenance area	0.56
Workshop	1.14
BUILDING TYPE SPECIFIC SPACE TYPES ^a	LPD (watts/sq.ft)
Automotive (see Vehicular maintenance area)	
Convention Center—exhibit space	0.88
Dormitory—living quarters ^{c, d}	0.54
Facility for the visually impaired ^b	
In a chapel (and not used primarily by the staff)	1.06
In a recreation room (and not used primarily by the staff)	1.80
Fire Station—sleeping quarters ^c	0.20
Gymnasium/fitness center	
In an exercise area	0.50
In a playing area	0.82

(continued)

**TABLE C405.3.2(2)—continued
INTERIOR LIGHTING POWER ALLOWANCES:
SPACE-BY-SPACE METHOD**

BUILDING TYPE SPECIFIC SPACE TYPES ^a	LPD (watts/sq.ft)
Healthcare facility	
In an exam/treatment room	1.68
In an imaging room	1.06
In a medical supply room	0.54
In a nursery	1.00
In a nurse's station	0.81
In an operating room	2.17
In a patient room ^c	0.62
In a physical therapy room	0.84
In a recovery room	1.03
Library	
In a reading area	0.82
In the stacks	1.20
Manufacturing facility	
In a detailed manufacturing area	0.93
In an equipment room	0.65
In an extra-high-bay area (greater than 50' floor-to-ceiling height)	1.05
In a high-bay area (25-50' floor-to-ceiling height)	0.75
In a low-bay area (less than 25' floor-to-ceiling height)	0.96
Museum	
In a general exhibition area	1.05
In a restoration room	0.85
Performing arts theater—dressing room	0.36
Post office—sorting area	0.68
Religious buildings	
In a fellowship hall	0.55
In a worship/pulpit/choir area	1.53
Retail facilities	
In a dressing/fitting room	0.50
In a mall concourse	0.90
Sports arena—playing area	
For a Class I facility ^c	2.47
For a Class II facility ^f	1.96
For a Class III facility ^g	1.70
For a Class IV facility ^h	1.13

(continued)

**TABLE C405.3.2(2)—continued
INTERIOR LIGHTING POWER ALLOWANCES:
SPACE-BY-SPACE METHOD**

BUILDING TYPE SPECIFIC SPACE TYPES ^a	LPD (watts/sq.ft)
Transportation facility	
In a baggage/carousel area	0.45
In an airport concourse	0.31
At a terminal ticket counter	0.62
Warehouse—storage area	
For medium to bulky, palletized items	0.35
For smaller, hand-carried items	0.69

- a. In cases where both a common space type and a building area specific space type are listed, the building area specific space type shall apply
- b. A 'Facility for the Visually Impaired' is a facility that is licensed or will be licensed by local or state authorities for senior long-term care, adult daycare, senior support or people with special visual needs.
- c. Where sleeping units are excluded from lighting power calculations by application of Section R405.1, neither the area of the sleeping units nor the wattage of lighting in the sleeping units is counted.
- d. Where dwelling units are excluded from lighting power calculations by application of Section R405.1, neither the area of the dwelling units nor the wattage of lighting in the dwelling units is counted.
- e. Class I facilities consist of professional facilities; and semiprofessional, collegiate, or club facilities with seating for 5,000 or more spectators.
- f. Class II facilities consist of collegiate and semiprofessional facilities with seating for fewer than 5,000 spectators; club facilities with seating for between 2,000 and 5,000 spectators; and amateur league and high-school facilities with seating for more than 2,000 spectators.
- g. Class III facilities consist of club, amateur league and high-school facilities with seating for 2,000 or fewer spectators.
- h. Class IV facilities consist of elementary school and recreational facilities; and amateur league and high-school facilities without provision for spectators.

in the interior lighting power allowance is permitted in the following cases:

1. For lighting equipment to be installed in sales areas specifically to highlight merchandise, the additional lighting power shall be determined in accordance with Equation 4-11.

$$\text{Additional interior lighting power allowance} = 1000 \text{ W} + (\text{Retail Area 1} \times 0.45 \text{ W/ft}^2) + (\text{Retail Area 2} \times 0.45 \text{ W/ft}^2) + (\text{Retail Area 3} \times 1.05 \text{ W/ft}^2) + (\text{Retail Area 4} \times 1.87 \text{ W/ft}^2)$$

For SI units:

$$\text{Additional interior lighting power allowance} = 1000 \text{ W} + (\text{Retail Area 1} \times 4.8 \text{ W/m}^2) + (\text{Retail Area 2} \times 4.84 \text{ W/m}^2) + (\text{Retail Area 3} \times 11 \text{ W/m}^2) + (\text{Retail Area 4} \times 20 \text{ W/m}^2)$$

(Equation 4-11)

where:

Retail Area 1 = The floor area for all products not listed in Retail Area 2, 3 or 4.

Retail Area 2 = The floor area used for the sale of vehicles, sporting goods and small electronics.

Retail Area 3 = The floor area used for the sale of furniture, clothing, cosmetics and artwork.

Retail Area 4 = The floor area used for the sale of jewelry, crystal and china.

Exception: Other merchandise categories are permitted to be included in Retail Areas 2 through 4, provided that justification documenting the need for additional lighting power based on visual inspection, contrast, or other critical display is approved by the code official.

2. For spaces in which lighting is specified to be installed in addition to the general lighting for the purpose of decorative appearance or for highlighting art or exhibits, provided that the additional lighting power shall be not more than 0.9 W/ft² (9.7 W/m²) in lobbies and not more than 0.75 W/ft² (8.1 W/m²) in other spaces.

C405.4 Exterior lighting power requirements (Mandatory). The total connected exterior lighting power calculated in accordance with Section C405.4.1 shall be not greater than the exterior lighting power allowance calculated in accordance with Section C405.4.2.

C405.4.1 Total connected exterior building exterior lighting power. The total exterior connected lighting power shall be the total maximum rated wattage of all lighting that is powered through the energy service for the building.

Exception: Lighting used for the following applications shall not be included.

1. Lighting *approved* because of safety considerations.
2. Emergency lighting automatically off during normal business operation.
3. Exit signs.
4. Specialized signal, directional and marker lighting associated with transportation.
5. Advertising signage or directional signage.
6. Integral to equipment or instrumentation and installed by its manufacturer.
7. Theatrical purposes, including performance, stage, film production and video production.
8. Athletic playing areas.
9. Temporary lighting.
10. Industrial production, material handling, transportation sites and associated storage areas.
11. Theme elements in theme/amusement parks.
12. Used to highlight features of art, public monuments, and the national flag.
13. Lighting for water features and swimming pools.
14. Lighting controlled from within dwelling units, where the lighting complies with Section R404.1.

C405.4.2 Exterior lighting power allowance. The total exterior lighting power allowance is the sum of the base site allowance plus the individual allowances for areas that are to be illuminated by lighting that is powered through the energy service for the building. Lighting power allowances are as specified in Table C405.4.2(2). The lighting zone for the building exterior is determined in accordance with Table C405.4.2(1) unless otherwise specified by the *code official*.

**TABLE C405.4.2(1)
EXTERIOR LIGHTING ZONES**

LIGHTING ZONE	DESCRIPTION
1	Developed areas of national parks, state parks, forest land, and rural areas
2	Areas predominantly consisting of residential zoning, neighborhood business districts, light industrial with limited nighttime use and residential mixed-use areas
3	All other areas not classified as lighting zone 1, 2 or 4
4	High-activity commercial districts in major metropolitan areas as designated by the local land use planning authority

C405.4.2.1 Additional exterior lighting power. Any increase in the exterior lighting power allowance is limited to the specific lighting applications indicated in Table C405.4.2(3). The additional power shall be used only for the luminaires that are serving these applications and shall not be used for any other purpose.

C405.4.3 Gas lighting (Mandatory). Gas-fired lighting appliances shall not be equipped with continuously burning pilot ignition systems.

C405.5 Dwelling electrical meter (Mandatory). Each dwelling unit located in a *Group R-2* building shall have a separate electrical meter.

C405.6 Electrical transformers (Mandatory). Low-voltage dry-type distribution electric transformers shall meet the minimum efficiency requirements of Table C405.6 as tested and rated in accordance with the test procedure listed in DOE 10 CFR 431. The efficiency shall be verified through certification under an approved certification program or, where a certification program does not exist, the equipment efficiency ratings shall be supported by data furnished by the transformer manufacturer.

Exceptions: The following transformers are exempt:

1. Transformers that meet the *Energy Policy Act of 2005* exclusions based on the DOE 10 CFR 431 definition of special purpose applications.
2. Transformers that meet the *Energy Policy Act of 2005* exclusions that are not to be used in general purpose applications based on information provided in DOE 10 CFR 431.
3. Transformers that meet the *Energy Policy Act of 2005* exclusions with multiple voltage taps where the highest tap is not less than 20 percent more than the lowest tap.

4. Drive transformers.
5. Rectifier transformers.
6. Auto-transformers.
7. Uninterruptible power system transformers.
8. Impedance transformers.
9. Regulating transformers.
10. Sealed and nonventilating transformers.
11. Machine tool transformers.
12. Welding transformers.
13. Grounding transformers.
14. Testing transformers.

C405.7 Electric motors (Mandatory). Electric motors shall meet the minimum efficiency requirements of Tables C405.7(1) through C405.7(4) when tested and rated in accordance with the DOE 10 CFR 431. The efficiency shall be verified through certification under an approved certification program or, where a certification program does not exist, the equipment efficiency ratings shall be supported by data furnished by the motor manufacturer.

Exception: The standards in this section shall not apply to the following exempt electric motors:

1. Air-over electric motors.
2. Component sets of an electric motor.
3. Liquid-cooled electric motors.
4. Submersible electric motors.
5. Inverter-only electric motors.

C405.8 Vertical and horizontal transportation systems and equipment. Vertical and horizontal transportation systems and equipment shall comply with this section.

C405.8.1 Elevator cabs. For the luminaires in each elevator cab, not including signals and displays, the sum of the lumens divided by the sum of the watts shall be not less than 35 lumens per watt. Ventilation fans in elevators that do not have their own air-conditioning system shall not consume more than 0.33 watts/cfm at the maximum rated speed of the fan. Controls shall be provided that will de-energize ventilation fans and lighting systems when the elevator is stopped, unoccupied and with its doors closed for over 15 minutes.

C405.8.2 Escalators and moving walks. Escalators and moving walks shall comply with ASME A17.1/CSA B44 and shall have automatic controls configured to reduce speed to the minimum permitted speed in accordance with ASME A17.1/CSA B44 or applicable local code when not conveying passengers.

Exception: A variable voltage drive system that reduces operating voltage in response to light loading conditions is an alternative to the reduced speed function.

C405.8.2.1 Regenerative drive. An escalator designed either for one-way down operation only or for reversible operation shall have a variable frequency regenerative drive that supplies electrical energy to the building electrical system when the escalator is loaded with passengers whose combined weight exceeds 750 pounds (340 kg).

**TABLE C405.4.2(2)
LIGHTING POWER ALLOWANCES FOR BUILDING EXTERIORS**

	LIGHTING ZONES			
	Zone 1	Zone 2	Zone 3	Zone 4
Base Site Allowance	350 W	400 W	500 W	900 W
Uncovered Parking Areas				
Parking areas and drives	0.03W/ft ²	0.04 W/ft ²	0.06 W/ft ²	0.08 W/ft ²
Building Grounds				
Walkways and ramps less than 10 feet wide	0.5 W/linear foot	0.5 W/linear foot	0.6 W/linear foot	0.7 W/linear foot
Walkways and ramps 10 feet wide or greater, plaza areas, special feature areas	0.10 W/ft ²	0.10 W/ft ²	0.11 W/ft ²	0.14 W/ft ²
Dining areas	0.65 W/ft ²	0.65 W/ft ²	0.75 W/ft ²	0.95 W/ft ²
Stairways	0.6 W/ft ²	0.7 W/ft ²	0.7 W/ft ²	0.7 W/ft ²
Pedestrian tunnels	0.12 W/ft ²	0.12 W/ft ²	0.14 W/ft ²	0.21 W/ft ²
Landscaping	0.03 W/ft ²	0.04 W/ft ²	0.04 W/ft ²	0.04 W/ft ²
Building Entrances and Exits				
Pedestrian and vehicular entrances and exits	14 W/linear foot of opening	14 W/linear foot of opening	21 W/linear foot of opening	21 W/linear foot of opening
Entry canopies	0.02 W/ft ²	0.25 W/ft ²	0.4 W/ft ²	0.4 W/ft ²
Loading docks	0.35 W/ft ²	0.35 W/ft ²	0.35 W/ft ²	0.35 W/ft ²
Sales Canopies				
Free-standing and attached	0.04 W/ft ²	0.04 W/ft ²	0.6 W/ft ²	0.7 W/ft ²
Outdoor Sales				
Open areas (including vehicle sales lots)	0.02 W/ft ²	0.02 W/ft ²	0.35 W/ft ²	0.05 W/ft ²
Street frontage for vehicle sales lots in addition to "open area" allowance	No allowance	7 W/linear foot	7 W/linear foot	21 W/linear foot

For SI: 1 foot = 304.8 mm, 1 watt per square foot = W/0.0929 m².
W = watts.

**TABLE C405.4.2(3)
INDIVIDUAL LIGHTING POWER ALLOWANCES FOR BUILDING EXTERIORS**

	LIGHTING ZONES			
	Zone 1	Zone 2	Zone 3	Zone 4
Building facades	No allowance	0.075 W/ft ² of gross above-grade wall area	0.113 W/ft ² of gross above-grade wall area	0.15 W/ft ² of gross above-grade wall area
Automated teller machines (ATM) and night depositories	135 W per location plus 45 W per additional ATM per location			
Uncovered entrances and gatehouse inspection stations at guarded facilities	0.5 W/ft ² of area			
Uncovered loading areas for law enforcement, fire, ambulance and other emergency service vehicles	0.35 W/ft ² of area			
Drive-up windows and doors	200 W per drive through			
Parking near 24-hour retail entrances.	400 W per main entry			

For SI: 1 watt per square foot = W/0.0929 m².
W = watts.

**TABLE C405.6
MINIMUM NOMINAL EFFICIENCY LEVELS FOR 10 CFR 431 LOW-VOLTAGE DRY-TYPE DISTRIBUTION TRANSFORMERS**

SINGLE-PHASE TRANSFORMERS		THREE-PHASE TRANSFORMERS	
kVA ^a	Efficiency (%) ^b	kVA ^a	Efficiency (%) ^b
15	97.70	15	97.89
25	98.00	30	98.23
37.5	98.20	45	98.40
50	98.30	75	98.60
75	98.50	112.5	98.74
100	98.60	150	98.83
167	98.70	225	98.94
250	98.80	300	99.02
333	98.90	500	99.14
—	—	750	99.23
—	—	1000	99.28

a. kiloVolt-Amp rating.

b. Nominal efficiencies shall be established in accordance with the DOE 10 CFR 431 test procedure for low-voltage dry-type transformers.

C405.9 Voltage drop in feeders and branch circuits. The total *voltage drop* across the combination of feeders and branch circuits shall not exceed 5 percent.

**SECTION C406
ADDITIONAL EFFICIENCY PACKAGE OPTIONS**

C406.1 Requirements. Buildings shall comply with one or more of the following:

1. More efficient HVAC performance in accordance with Section C406.2.
2. Reduced lighting power in accordance with Section C406.3.
3. Enhanced lighting controls in accordance with Section C406.4.
4. On-site supply of renewable energy in accordance with Section C406.5.
5. Provision of a dedicated outdoor air system for certain HVAC equipment in accordance with Section C406.6.
6. High-efficiency service water heating in accordance with Section C406.7.
7. Enhanced envelope performance in accordance with Section C406.8.
8. Reduced air infiltration in accordance with Section C406.9

C406.1.1 Tenant spaces. Tenant spaces shall comply with Section C406.2, C406.3, C406.4, C406.6 or C406.7. Alternatively, tenant spaces shall comply with Section C406.5 where the entire building is in compliance.

Exception: Previously occupied tenant spaces that comply with this code in accordance with Section C501.

C406.2 More efficient HVAC equipment performance. Equipment shall exceed the minimum efficiency require-

ments listed in Tables C403.3.2(1) through C403.3.2(7) by 10 percent, in addition to the requirements of Section C403. Where multiple performance requirements are provided, the equipment shall exceed all requirements by 10 percent. *Variable refrigerant flow systems* shall exceed the energy efficiency provisions of ANSI/ASHRAE/IESNA 90.1 by 10 percent. Equipment not listed in Tables C403.3.2(1) through C403.3.2(7) shall be limited to 10 percent of the total building system capacity.

C406.3 Reduced lighting power. The total connected interior lighting power calculated in accordance with Section C405.3.1 shall be less than 90 percent of the total lighting power allowance calculated in accordance with Section C405.3.2.

C406.4 Enhanced digital lighting controls. Interior lighting in the building shall have the following enhanced lighting controls that shall be located, scheduled and operated in accordance with Section C405.2.2.

1. Luminaires shall be configured for continuous dimming.
2. Luminaires shall be addressed individually. Where individual addressability is not available for the luminaire class type, a controlled group of not more than four luminaires shall be allowed.
3. Not more than eight luminaires shall be controlled together in a *daylight zone*.
4. Fixtures shall be controlled through a digital control system that includes the following function:
 - 4.1. Control reconfiguration based on digital addressability.
 - 4.2. Load shedding.
 - 4.3. Individual user control of overhead general illumination in open offices.
 - 4.4. Occupancy sensors shall be capable of being reconfigured through the digital control system.

TABLE C405.7(1)
MINIMUM NOMINAL FULL-LOAD EFFICIENCY FOR NEMA DESIGN A, NEMA DESIGN B,
AND IEC DESIGN N MOTORS (EXCLUDING FIRE PUMP) ELECTRIC MOTORS AT 60 HZ^{a, b}

MOTOR HORSEPOWER (STANDARD KILOWATT EQUIVALENT)	NOMINAL FULL-LOAD EFFICIENCY (%) AS OF JUNE 1, 2016							
	2 Pole		4 Pole		6 Pole		8 Pole	
	Enclosed	Open	Enclosed	Open	Enclosed	Open	Enclosed	Open
1 (0.75)	77.0	77.0	85.5	85.5	82.5	82.5	75.5	75.5
1.5 (1.1)	84.0	84.0	86.5	86.5	87.5	86.5	78.5	77.0
2 (1.5)	85.5	85.5	86.5	86.5	88.5	87.5	84.0	86.5
3 (2.2)	86.5	85.5	89.5	89.5	89.5	88.5	85.5	87.5
5 (3.7)	88.5	86.5	89.5	89.5	89.5	89.5	86.5	88.5
7.5 (5.5)	89.5	88.5	91.7	91.0	91.0	90.2	86.5	89.5
10 (7.5)	90.2	89.5	91.7	91.7	91.0	91.7	89.5	90.2
15 (11)	91.0	90.2	92.4	93.0	91.7	91.7	89.5	90.2
20 (15)	91.0	91.0	93.0	93.0	91.7	92.4	90.2	91.0
25 (18.5)	91.7	91.7	93.6	93.6	93.0	93.0	90.2	91.0
30 (22)	91.7	91.7	93.6	94.1	93.0	93.6	91.7	91.7
40 (30)	92.4	92.4	94.1	94.1	94.1	94.1	91.7	91.7
50 (37)	93.0	93.0	94.5	94.5	94.1	94.1	92.4	92.4
60 (45)	93.6	93.6	95.0	95.0	94.5	94.5	92.4	93.0
75 (55)	93.6	93.6	95.4	95.0	94.5	94.5	93.6	94.1
100 (75)	94.1	93.6	95.4	95.4	95.0	95.0	93.6	94.1
125 (90)	95.0	94.1	95.4	95.4	95.0	95.0	94.1	94.1
150 (110)	95.0	94.1	95.8	95.8	95.8	95.4	94.1	94.1
200 (150)	95.4	95.0	96.2	95.8	95.8	95.4	94.5	94.1
250 (186)	95.8	95.0	96.2	95.8	95.8	95.8	95.0	95.0
300 (224)	95.8	95.4	96.2	95.8	95.8	95.8		
350 (261)	95.8	95.4	96.2	95.8	95.8	95.8		
400 (298)	95.8	95.8	96.2	95.8				
450 (336)	95.8	96.2	96.2	96.2				
500 (373)	95.8	96.2	96.2	96.2				

- a. Nominal efficiencies shall be established in accordance with DOE 10 CFR 431.
- b. For purposes of determining the required minimum nominal full-load efficiency of an electric motor that has a horsepower or kilowatt rating between two horsepower or two kilowatt ratings listed in this table, each such motor shall be deemed to have a listed horsepower or kilowatt rating, determined as follows:
 - 1. A horsepower at or above the midpoint between the two consecutive horsepowers shall be rounded up to the higher of the two horsepowers.
 - 2. A horsepower below the midpoint between the two consecutive horsepowers shall be rounded down to the lower of the two horsepowers.
 - 3. A kilowatt rating shall be directly converted from kilowatts to horsepower using the formula: 1 kilowatt = (1/0.746) horsepower. The conversion should be calculated to three significant decimal places, and the resulting horsepower shall be rounded in accordance with No. 1 or No. 2 above, as applicable.

TABLE C405.7(2)
MINIMUM NOMINAL FULL-LOAD EFFICIENCY FOR NEMA DESIGN C AND IEC DESIGN H MOTORS AT 60 HZ^{a, b}

MOTOR HORSEPOWER (STANDARD KILOWATT EQUIVALENT)	NOMINAL FULL-LOAD EFFICIENCY (%) AS OF JUNE 1, 2016					
	4 Pole		6 Pole		8 Pole	
	Enclosed	Open	Enclosed	Open	Enclosed	Open
1 (0.75)	85.5	85.5	82.5	82.5	75.5	75.5
1.5 (1.1)	86.5	86.5	87.5	86.5	78.5	77.0
2 (1.5)	86.5	86.5	88.5	87.5	84.0	86.5
3 (2.2)	89.5	89.5	89.5	88.5	85.5	87.5
5 (3.7)	89.5	89.5	89.5	89.5	86.5	88.5
7.5 (5.5)	91.7	91.0	91.0	90.2	86.5	89.5
10 (7.5)	91.7	91.7	91.0	91.7	89.5	90.2
15 (11)	92.4	93.0	91.7	91.7	89.5	90.2
20 (15)	93.0	93.0	91.7	92.4	90.2	91.0
25 (18.5)	93.6	93.6	93.0	93.0	90.2	91.0
30 (22)	93.6	94.1	93.0	93.6	91.7	91.7
40 (30)	94.1	94.1	94.1	94.1	91.7	91.7
50 (37)	94.5	94.5	94.1	94.1	92.4	92.4
60 (45)	95.0	95.0	94.5	94.5	92.4	93.0
75 (55)	95.4	95.0	94.5	94.5	93.6	94.1
100 (75)	95.4	95.4	95.0	95.0	93.6	94.1
125 (90)	95.4	95.4	95.0	95.0	94.1	94.1
150 (110)	95.8	95.8	95.8	95.4	94.1	94.1
200 (150)	96.2	95.8	95.8	95.4	94.5	94.1

- a. Nominal efficiencies shall be established in accordance with DOE 10 CFR 431.
- b. For purposes of determining the required minimum nominal full-load efficiency of an electric motor that has a horsepower or kilowatt rating between two horsepower or two kilowatt ratings listed in this table, each such motor shall be deemed to have a listed horsepower or kilowatt rating, determined as follows:
 - 1. A horsepower at or above the midpoint between the two consecutive horsepowers shall be rounded up to the higher of the two horsepowers.
 - 2. A horsepower below the midpoint between the two consecutive horsepowers shall be rounded down to the lower of the two horsepowers.
 - 3. A kilowatt rating shall be directly converted from kilowatts to horsepower using the formula: 1 kilowatt = (1/0.746) horsepower. The conversion should be calculated to three significant decimal places, and the resulting horsepower shall be rounded in accordance with No. 1 or No. 2 above, as applicable.

TABLE C405.7(3)
MINIMUM AVERAGE FULL-LOAD EFFICIENCY POLYPHASE SMALL ELECTRIC MOTORS^a

MOTOR HORSEPOWER	OPEN MOTORS			
	Number of Poles	2	4	6
	Synchronous Speed (RPM)	3600	1800	1200
0.25		65.6	69.5	67.5
0.33		69.5	73.4	71.4
0.50		73.4	78.2	75.3
0.75		76.8	81.1	81.7
1		77.0	83.5	82.5
1.5		84.0	86.5	83.8
2		85.5	86.5	N/A
3		85.5	86.9	N/A

- a. Average full-load efficiencies shall be established in accordance with DOE 10 CFR 431.

TABLE C405.7(4)
MINIMUM AVERAGE FULL-LOAD EFFICIENCY FOR
CAPACITOR-START CAPACITOR-RUN AND CAPACITOR-START INDUCTION-RUN SMALL ELECTRIC MOTORS^a

MOTOR HORSEPOWER	OPEN MOTORS			
	Number of Poles	2	4	6
	Synchronous Speed (RPM)	3600	1800	1200
0.25		66.6	68.5	62.2
0.33		70.5	72.4	66.6
0.50		72.4	76.2	76.2
0.75		76.2	81.8	80.2
1		80.4	82.6	81.1
1.5		81.5	83.8	N/A
2		82.9	84.5	N/A
3		84.1	N/A	N/A

a. Average full-load efficiencies shall be established in accordance with DOE 10 CFR 431.

5. Construction documents shall include submittal of a Sequence of Operations, including a specification outlining each of the functions in Item 4.
6. Functional testing of lighting controls shall comply with Section C408.

C406.5 On-site renewable energy. The total minimum ratings of on-site renewable energy systems shall be one of the following:

1. Not less than 1.71 Btu/h per square foot (5.4 W/m²) or 0.50 watts per square foot (5.4 W/m²) of conditioned floor area.
2. Not less than 3 percent of the energy used within the building for building mechanical and service water heating equipment and lighting regulated in Chapter 4.

C406.6 Dedicated outdoor air system. Buildings containing equipment or systems regulated by Section C403.3.4, C403.4.3, C403.4.4, C403.4.5, C403.6, C403.8.4, C403.8.5, C403.8.5.1, C403.9.1, C403.9.2, C403.9.3 or C403.9.4 shall be equipped with an independent ventilation system designed to provide not less than the minimum 100-percent outdoor air to each individual occupied space, as specified by the *International Mechanical Code*. The ventilation system shall be capable of total energy recovery. The HVAC system shall include supply-air temperature controls that automatically reset the supply-air temperature in response to representative building loads, or to outdoor air temperatures. The controls shall reset the supply-air temperature not less than 25 percent of the difference between the design supply-air temperature and the design room-air temperature.

C406.7 Reduced energy use in service water heating. Buildings shall be of the following types to use this compliance method:

1. *Group R-1:* Boarding houses, hotels or motels.
2. *Group I-2:* Hospitals, psychiatric hospitals and nursing homes.
3. *Group A-2:* Restaurants and banquet halls or buildings containing food preparation areas.
4. *Group F:* Laundries.

5. *Group R-2.*
6. *Group A-3:* Health clubs and spas.
7. Buildings showing a service hot water load of 10 percent or more of total building energy loads, as shown with an energy analysis as described in Section C407.

C406.7.1 Load fraction. The building service water-heating system shall have one or more of the following that are sized to provide not less than 60 percent of the building's annual hot water requirements, or sized to provide 100 percent of the building's annual hot water requirements if the building shall otherwise comply with Section C403.9.5:

1. Waste heat recovery from service hot water, heat-recovery chillers, building equipment, or process equipment.
2. *On-site renewable energy* water-heating systems.

C406.8 Enhanced envelope performance. The total UA of the building thermal envelope as designed shall be not less than 15 percent below the total UA of the building thermal envelope in accordance with Section C402.1.5.

C406.9 Reduced air infiltration. Air infiltration shall be verified by whole-building pressurization testing conducted in accordance with ASTM E779 or ASTM E1827 by an independent third party. The measured air-leakage rate of the building envelope shall not exceed 0.25 cfm/ft² (2.0 L/s × m²) under a pressure differential of 0.3 inches water column (75 Pa), with the calculated surface area being the sum of the above- and below-grade building envelope. A report that includes the tested surface area, floor area, air by volume, stories above grade, and leakage rates shall be submitted to the code official and the building owner.

Exception: For buildings having over 250,000 square feet (25 000 m²) of conditioned floor area, air leakage testing need not be conducted on the whole building where testing is conducted on representative above-grade sections of the building. Tested areas shall total not less than 25 percent of the conditioned floor area and shall be tested in accordance with this section.

SECTION C407 TOTAL BUILDING PERFORMANCE

C407.1 Scope. This section establishes criteria for compliance using total building performance. The following systems and loads shall be included in determining the total building performance: heating systems, cooling systems, service water heating, fan systems, lighting power, receptacle loads and process loads.

Exception: Energy used to recharge or refuel vehicles that are used for on-road and off-site transportation purposes.

C407.2 Mandatory requirements. Compliance with this section requires compliance with Sections C402.5, C403.2, C403.3 through C403.3.2, C403.4 through C403.4.2.3, C403.5.5, C403.7, C403.8.1 through C403.8.4, C403.10.1 through C403.10.3, C403.11, C403.12, C404 and C405.

C407.3 Performance-based compliance. Compliance based on total building performance requires that a proposed building (*proposed design*) be shown to have an annual energy cost that is less than or equal to the annual energy cost of the *standard reference design*. Energy prices shall be taken from a source *approved* by the *code official*, such as the Department of Energy, Energy Information Administration's *State Energy Price and Expenditure Report*. *Code officials* shall be permitted to require time-of-use pricing in energy cost calculations. The reduction in energy cost of the proposed design associated with *on-site renewable energy* shall be not more than 5 percent of the total energy cost. The amount of renewable energy purchased from off-site sources shall be the same in the *standard reference design* and the *proposed design*.

Exception: Jurisdictions that require site energy (1 kWh = 3413 Btu) rather than energy cost as the metric of comparison.

C407.4 Documentation. Documentation verifying that the methods and accuracy of compliance software tools conform to the provisions of this section shall be provided to the *code official*.

C407.4.1 Compliance report. Permit submittals shall include a report documenting that the proposed design has annual energy costs less than or equal to the annual energy costs of the standard reference design. The compliance documentation shall include the following information:

1. Address of the building.
2. An inspection checklist documenting the building component characteristics of the *proposed design* as specified in Table C407.5.1(1). The inspection checklist shall show the estimated annual energy cost for both the *standard reference design* and the *proposed design*.
3. Name of individual completing the compliance report.
4. Name and version of the compliance software tool.

C407.4.2 Additional documentation. The *code official* shall be permitted to require the following documents:

1. Documentation of the building component characteristics of the *standard reference design*.
2. Thermal zoning diagrams consisting of floor plans showing the thermal zoning scheme for *standard reference design* and *proposed design*.
3. Input and output reports from the energy analysis simulation program containing the complete input and output files, as applicable. The output file shall include energy use totals and energy use by energy source and end-use served, total hours that space conditioning loads are not met and any errors or warning messages generated by the simulation tool as applicable.
4. An explanation of any error or warning messages appearing in the simulation tool output.
5. A certification signed by the builder providing the building component characteristics of the *proposed design* as given in Table C407.5.1(1).
6. Documentation of the reduction in energy use associated with *on-site renewable energy*.

C407.5 Calculation procedure. Except as specified by this section, the *standard reference design* and *proposed design* shall be configured and analyzed using identical methods and techniques.

C407.5.1 Building specifications. The *standard reference design* and *proposed design* shall be configured and analyzed as specified by Table C407.5.1(1). Table C407.5.1(1) shall include by reference all notes contained in Table C402.1.4.

C407.5.2 Thermal blocks. The *standard reference design* and *proposed design* shall be analyzed using identical thermal blocks as specified in Section C407.5.2.1, C407.5.2.2 or C407.5.2.3.

C407.5.2.1 HVAC zones designed. Where HVAC *zones* are defined on HVAC design drawings, each HVAC *zone* shall be modeled as a separate thermal block.

Exception: Different HVAC *zones* shall be allowed to be combined to create a single thermal block or identical thermal blocks to which multipliers are applied, provided that:

1. The space use classification is the same throughout the thermal block.
2. All HVAC *zones* in the thermal block that are adjacent to glazed exterior walls face the same orientation or their orientations are within 45 degrees (0.79 rad) of each other.
3. All of the *zones* are served by the same HVAC system or by the same kind of HVAC system.

TABLE C407.5.1(1)
SPECIFICATIONS FOR THE STANDARD REFERENCE AND PROPOSED DESIGNS

BUILDING COMPONENT CHARACTERISTICS	STANDARD REFERENCE DESIGN	PROPOSED DESIGN
Space use classification	Same as proposed	The space use classification shall be chosen in accordance with Table C405.5.2 for all areas of the building covered by this permit. Where the space use classification for a building is not known, the building shall be categorized as an office building.
Roofs	Type: Insulation entirely above deck	As proposed
	Gross area: same as proposed	As proposed
	<i>U</i> -factor: as specified in Table C402.1.4	As proposed
	Solar absorptance: 0.75	As proposed
	Emittance: 0.90	As proposed
Walls, above-grade	Type: Mass wall where proposed wall is mass; otherwise steel-framed wall	As proposed
	Gross area: same as proposed	As proposed
	<i>U</i> -factor: as specified in Table C402.1.4	As proposed
	Solar absorptance: 0.75	As proposed
	Emittance: 0.90	As proposed
Walls, below-grade	Type: Mass wall	As proposed
	Gross area: same as proposed	As proposed
	<i>U</i> -Factor: as specified in Table C402.1.4 with insulation layer on interior side of walls	As proposed
Floors, above-grade	Type: joist/framed floor	As proposed
	Gross area: same as proposed	As proposed
	<i>U</i> -factor: as specified in Table C402.1.4	As proposed
Floors, slab-on-grade	Type: Unheated	As proposed
	<i>F</i> -factor: as specified in Table C402.1.4	As proposed
Opaque doors	Type: Swinging	As proposed
	Area: Same as proposed	As proposed
	<i>U</i> -factor: as specified in Table C402.1.4	As proposed
Vertical fenestration other than opaque doors	Area 1. The proposed vertical fenestration area; where the proposed vertical fenestration area is less than 40 percent of above-grade wall area. 2. 40 percent of above-grade wall area; where the proposed vertical fenestration area is 40 percent or more of the above-grade wall area.	As proposed
	<i>U</i> -factor: as specified in Table C402.4	As proposed
	SHGC: as specified in Table C402.4 except that for climates with no requirement (NR) SHGC = 0.40 shall be used	As proposed
	External shading and PF: None	As proposed
Skylights	Area 1. The proposed skylight area; where the proposed skylight area is less than that permitted by Section C402.1. 2. The area permitted by Section C402.1; where the proposed skylight area exceeds that permitted by Section C402.1	As proposed
	<i>U</i> -factor: as specified in Table C402.4	As proposed
	SHGC: as specified in Table C402.4 except that for climates with no requirement (NR) SHGC = 0.40 shall be used.	As proposed
Lighting, interior	The interior lighting power shall be determined in accordance with Section C405.3.2. Where the occupancy of the building is not known, the lighting power density shall be 1.0 Watt per square foot (10.7 W/m ²) based on the categorization of buildings with unknown space classification as offices.	As proposed
Lighting, exterior	The lighting power shall be determined in accordance with Table C405.4.2(2) and C405.4.2(3). Areas and dimensions of surfaces shall be the same as proposed.	As proposed

(continued)

TABLE C407.5.1(1)—continued
SPECIFICATIONS FOR THE STANDARD REFERENCE AND PROPOSED DESIGNS

BUILDING COMPONENT CHARACTERISTICS	STANDARD REFERENCE DESIGN	PROPOSED DESIGN
Internal gains	Same as proposed	Receptacle, motor and process loads shall be modeled and estimated based on the space use classification. End-use load components within and associated with the building shall be modeled to include, but not be limited to, the following: exhaust fans, parking garage ventilation fans, exterior building lighting, swimming pool heaters and pumps, elevators, escalators, refrigeration equipment and cooking equipment.
Schedules	Same as proposed Exception: Thermostat settings and schedules for HVAC systems that utilize radiant heating, radiant cooling and elevated air speed, provided that equivalent levels of occupant thermal comfort are demonstrated by means of equal Standard Effective Temperature as calculated in Normative Appendix B of ASHRAE Standard 55.	Operating schedules shall include hourly profiles for daily operation and shall account for variations between weekdays, weekends, holidays and any seasonal operation. Schedules shall model the time-dependent variations in occupancy, illumination, receptacle loads, thermostat settings, mechanical ventilation, HVAC equipment availability, service hot water usage and any process loads. The schedules shall be typical of the proposed building type as determined by the designer and approved by the jurisdiction.
Mechanical ventilation	Same as proposed	As proposed, in accordance with Section C403.2.2.
Heating systems	Fuel type: same as proposed design	As proposed
	Equipment type ^a : as specified in Tables C407.5.1(2) and C407.5.1(3)	As proposed
	Efficiency: as specified in Tables C403.3.2(4) and C403.3.2(5)	As proposed
	Capacity ^b : sized proportionally to the capacities in the proposed design based on sizing runs, and shall be established such that no smaller number of unmet heating load hours and no larger heating capacity safety factors are provided than in the proposed design.	As proposed
Cooling systems	Fuel type: same as proposed design	As proposed
	Equipment type ^c : as specified in Tables C407.5.1(2) and C407.5.1(3)	As proposed
	Efficiency: as specified in Tables C403.3.2(1), C403.3.2(2) and C403.3.2(3)	As proposed
	Capacity ^b : sized proportionally to the capacities in the proposed design based on sizing runs, and shall be established such that no smaller number of unmet cooling load hours and no larger cooling capacity safety factors are provided than in the proposed design.	As proposed
Service water heating ^e	Fuel type: same as proposed	As proposed
	Efficiency: as specified in Table C404.2	For <i>Group R</i> , as proposed multiplied by SWHF. For other than <i>Group R</i> , as proposed multiplied by efficiency as provided by the manufacturer of the DWHR unit.
	Capacity: same as proposed	As proposed
	Where no service water hot water system exists or is specified in the proposed design, no service hot water heating shall be modeled.	

SWHF = Service water heat recovery factor, DWHR = Drain water heat recovery.

- a. Where no heating system exists or has been specified, the heating system shall be modeled as fossil fuel. The system characteristics shall be identical in both the standard reference design and proposed design.
- b. The ratio between the capacities used in the annual simulations and the capacities determined by sizing runs shall be the same for both the standard reference design and proposed design.
- c. Where no cooling system exists or no cooling system has been specified, the cooling system shall be modeled as an air-cooled single-zone system, one unit per thermal zone. The system characteristics shall be identical in both the standard reference design and proposed design.
- d. If an economizer is required in accordance with Table C403.5(1) and where no economizer exists or is specified in the proposed design, then a supply-air economizer shall be provided in the standard reference design in accordance with Section C403.5.
- e. The SWHF shall be applied as follows:
 1. Where potable water from the DWHR unit supplies not less than one shower and not greater than two showers, of which the drain water from the same showers flows through the DWHR unit then $SWHF = [1 - (DWHR \text{ unit efficiency} \cdot 0.36)]$.
 2. Where potable water from the DWHR unit supplies not less than three showers and not greater than four showers, of which the drain water from the same showers flows through the DWHR unit then $SWHF = [1 - (DWHR \text{ unit efficiency} \cdot 0.33)]$.
 3. Where potable water from the DWHR unit supplies not less than five showers and not greater than six showers, of which the drain water from the same showers flows through the DWHR unit, then $SWHF = [1 - (DWHR \text{ unit efficiency} \cdot 0.26)]$.
 4. Where Items 1 through 3 are not met, $SWHF = 1.0$.

**TABLE C407.5.1(2)
HVAC SYSTEMS MAP**

CONDENSER COOLING SOURCE ^a	HEATING SYSTEM CLASSIFICATION ^b	STANDARD REFERENCE DESIGN HVC SYSTEM TYPE ^c		
		Single-zone Residential System	Single-zone Nonresidential System	All Other
Water/ground	Electric resistance	System 5	System 5	System 1
	Heat pump	System 6	System 6	System 6
	Fossil fuel	System 7	System 7	System 2
Air/none	Electric resistance	System 8	System 9	System 3
	Heat pump	System 8	System 9	System 3
	Fossil fuel	System 10	System 11	System 4

- a. Select “water/ground” where the proposed design system condenser is water or evaporatively cooled; select “air/none” where the condenser is air cooled. Closed-circuit dry coolers shall be considered to be air cooled. Systems utilizing district cooling shall be treated as if the condenser water type were “water.” Where mechanical cooling is not specified or the mechanical cooling system in the proposed design does not require heat rejection, the system shall be treated as if the condenser water type were “Air.” For proposed designs with ground-source or groundwater-source heat pumps, the standard reference design HVAC system shall be water-source heat pump (System 6).
- b. Select the path that corresponds to the proposed design heat source: electric resistance, heat pump (including air source and water source), or fuel fired. Systems utilizing district heating (steam or hot water) and systems without heating capability shall be treated as if the heating system type were “fossil fuel.” For systems with mixed fuel heating sources, the system or systems that use the secondary heating source type (the one with the smallest total installed output capacity for the spaces served by the system) shall be modeled identically in the standard reference design and the primary heating source type shall be used to determine standard reference design HVAC system type.
- c. Select the standard reference design HVAC system category: The system under “single-zone residential system” shall be selected where the HVAC system in the proposed design is a single-zone system and serves a Group R occupancy. The system under “single-zone nonresidential system” shall be selected where the HVAC system in the proposed design is a single-zone system and serves other than Group R occupancy. The system under “all other” shall be selected for all other cases.

TABLE C407.5.1(3)
SPECIFICATIONS FOR THE STANDARD REFERENCE DESIGN HVAC SYSTEM DESCRIPTIONS

SYSTEM NO.	SYSTEM TYPE	FAN CONTROL	COOLING TYPE	HEATING TYPE
1	Variable air volume with parallel fan-powered boxes ^a	VAV ^d	Chilled water ^e	Electric resistance
2	Variable air volume with reheat ^b	VAV ^d	Chilled water ^e	Hot water fossil fuel boiler ^f
3	Packaged variable air volume with parallel fan-powered boxes ^a	VAV ^d	Direct expansion ^e	Electric resistance
4	Packaged variable air volume with reheat ^b	VAV ^d	Direct expansion ^e	Hot water fossil fuel boiler ^f
5	Two-pipe fan coil	Constant volume ⁱ	Chilled water ^e	Electric resistance
6	Water-source heat pump	Constant volume ⁱ	Direct expansion ^e	Electric heat pump and boiler ^g
7	Four-pipe fan coil	Constant volume ⁱ	Chilled water ^e	Hot water fossil fuel boiler ^f
8	Packaged terminal heat pump	Constant volume ⁱ	Direct expansion ^e	Electric heat pump ^h
9	Packaged rooftop heat pump	Constant volume ⁱ	Direct expansion ^e	Electric heat pump ^h
10	Packaged terminal air conditioner	Constant volume ⁱ	Direct expansion	Hot water fossil fuel boiler ^f
11	Packaged rooftop air conditioner	Constant volume ⁱ	Direct expansion	Fossil fuel furnace

For SI: 1 foot = 304.8 mm, 1 cfm/ft² = 0.4719 L/s, 1 Btu/h = 0.293/W, °C = [(°F) - 32]/1.8.

- a. **VAV with parallel boxes:** Fans in parallel VAV fan-powered boxes shall be sized for 50 percent of the peak design flow rate and shall be modeled with 0.35 W/cfm fan power. Minimum volume setpoints for fan-powered boxes shall be equal to the minimum rate for the space required for ventilation consistent with Section C403.6.1, Item 3. Supply air temperature setpoint shall be constant at the design condition.
- b. **VAV with reheat:** Minimum volume setpoints for VAV reheat boxes shall be 0.4 cfm/ft² of floor area. Supply air temperature shall be reset based on zone demand from the design temperature difference to a 10°F temperature difference under minimum load conditions. Design airflow rates shall be sized for the reset supply air temperature, i.e., a 10°F temperature difference.
- c. **Direct expansion:** The fuel type for the cooling system shall match that of the cooling system in the proposed design.
- d. **VAV:** Where the proposed design system has a supply, return or relief fan motor 25 hp or larger, the corresponding fan in the VAV system of the standard reference design shall be modeled assuming a variable-speed drive. For smaller fans, a forward-curved centrifugal fan with inlet vanes shall be modeled. Where the proposed design's system has a direct digital control system at the zone level, static pressure setpoint reset based on zone requirements in accordance with Section C403.8.5 shall be modeled.
- e. **Chilled water:** For systems using purchased chilled water, the chillers are not explicitly modeled and chilled water costs shall be based as determined in Sections C407.3 and C407.5.2. Otherwise, the standard reference design's chiller plant shall be modeled with chillers having the number as indicated in Table C407.5.1(4) as a function of standard reference building chiller plant load and type as indicated in Table C407.5.1(5) as a function of individual chiller load. Where chiller fuel source is mixed, the system in the standard reference design shall have chillers with the same fuel types and with capacities having the same proportional capacity as the proposed design's chillers for each fuel type. Chilled water supply temperature shall be modeled at 44°F design supply temperature and 56°F return temperature. Piping losses shall not be modeled in either building model. Chilled water supply water temperature shall be reset in accordance with Section C403.9.3. Pump system power for each pumping system shall be the same as the proposed design; where the proposed design has no chilled water pumps, the standard reference design pump power shall be 22 W/gpm (equal to a pump operating against a 75-foot head, 65-percent combined impeller and motor efficiency). The chilled water system shall be modeled as primary-only variable flow with flow maintained at the design rate through each chiller using a bypass. Chilled water pumps shall be modeled as riding the pump curve or with variable-speed drives where required in Section C403.9.3. The heat rejection device shall be an axial fan cooling tower with two-speed fans where required in Section C403.9. Condenser water design supply temperature shall be 85°F or 10°F approach to design wet-bulb temperature, whichever is lower, with a design temperature rise of 10°F. The tower shall be controlled to maintain a 70°F leaving water temperature where weather permits, floating up to leaving water temperature at design conditions. Pump system power for each pumping system shall be the same as the proposed design; where the proposed design has no condenser water pumps, the standard reference design pump power shall be 19 W/gpm (equal to a pump operating against a 60-foot head, 60-percent combined impeller and motor efficiency). Each chiller shall be modeled with separate condenser water and chilled water pumps interlocked to operate with the associated chiller.
- f. **Fossil fuel boiler:** For systems using purchased hot water or steam, the boilers are not explicitly modeled and hot water or steam costs shall be based on actual utility rates. Otherwise, the boiler plant shall use the same fuel as the proposed design and shall be natural draft. The standard reference design boiler plant shall be modeled with a single boiler where the standard reference design plant load is 600,000 Btu/h and less and with two equally sized boilers for plant capacities exceeding 600,000 Btu/h. Boilers shall be staged as required by the load. Hot water supply temperature shall be modeled at 180°F design supply temperature and 130°F return temperature. Piping losses shall not be modeled in either building model. Hot water supply water temperature shall be reset in accordance with Section C403.9.3. Pump system power for each pumping system shall be the same as the proposed design; where the proposed design has no hot water pumps, the standard reference design pump power shall be 19 W/gpm (equal to a pump operating against a 60-foot head, 60-percent combined impeller and motor efficiency). The hot water system shall be modeled as primary only with continuous variable flow. Hot water pumps shall be modeled as riding the pump curve or with variable speed drives where required by Section C403.9.3.
- g. **Electric heat pump and boiler:** Water-source heat pumps shall be connected to a common heat pump water loop controlled to maintain temperatures between 60°F and 90°F. Heat rejection from the loop shall be provided by an axial fan closed-circuit evaporative fluid cooler with two-speed fans where required in Section C403.8.5. Heat addition to the loop shall be provided by a boiler that uses the same fuel as the proposed design and shall be natural draft. Where no boilers exist in the proposed design, the standard reference building boilers shall be fossil fuel. The standard reference design boiler plant shall be modeled with a single boiler where the standard reference design plant load is 600,000 Btu/h or less and with two equally sized boilers for plant capacities exceeding 600,000 Btu/h. Boilers shall be staged as required by the load. Piping losses shall not be modeled in either building model. Pump system power shall be the same as the proposed design; where the proposed design has no pumps, the standard reference design pump power shall be 22 W/gpm, which is equal to a pump operating against a 75-foot head, with a 65-percent combined impeller and motor efficiency. Loop flow shall be variable with flow shutoff at each heat pump when its compressor cycles off as required by Section C403.9.3. Loop pumps shall be modeled as riding the pump curve or with variable speed drives where required by Section C403.9.3.
- h. **Electric heat pump:** Electric air-source heat pumps shall be modeled with electric auxiliary heat. The system shall be controlled with a multistage space thermostat and an outdoor air thermostat wired to energize auxiliary heat only on the last thermostat stage and when outdoor air temperature is less than 40°F.
- i. **Constant volume:** Fans shall be controlled in the same manner as in the proposed design; i.e., fan operation whenever the space is occupied or fan operation cycled on calls for heating and cooling. Where the fan is modeled as cycling and the fan energy is included in the energy efficiency rating of the equipment, fan energy shall not be modeled explicitly.

**TABLE C407.5.1(4)
NUMBER OF CHILLERS**

TOTAL CHILLER PLANT CAPACITY	NUMBER OF CHILLERS
≤ 300 tons	1
> 300 tons, < 600 tons	2, sized equally
≥ 600 tons	2 minimum, with chillers added so that all are sized equally and none is larger than 800 tons

For SI: 1 ton = 3517 W.

**TABLE C407.5.1(5)
WATER CHILLER TYPES**

INDIVIDUAL CHILLER PLANT CAPACITY	ELECTRIC CHILLER TYPE	FOSSIL FUEL CHILLER TYPE
≤ 100 tons	Reciprocating	Single-effect absorption, direct fired
> 100 tons, < 300 tons	Screw	Double-effect absorption, direct fired
≥ 300 tons	Centrifugal	Double-effect absorption, direct fired

For SI: 1 ton = 3517 W.

**SECTION C408
MAINTENANCE INFORMATION
AND SYSTEM COMMISSIONING**

C408.1 General. This section covers the provision of maintenance information and the commissioning of, and the functional testing requirements for, building systems.

C408.1.1 Building operations and maintenance information. The building operations and maintenance documents shall be provided to the owner and shall consist of manufacturers’ information, specifications and recommendations; programming procedures and data points; narratives; and other means of illustrating to the owner how the building, equipment and systems are intended to be installed, maintained and operated. Required regular maintenance actions for equipment and systems shall be clearly stated on a readily visible label. The label shall include the title or publication number for the operation and maintenance manual for that particular model and type of product.

C408.2 Mechanical systems and service water-heating systems commissioning and completion requirements. Prior to the final mechanical and plumbing inspections, the *registered design professional or approved agency* shall provide evidence of mechanical systems *commissioning* and completion in accordance with the provisions of this section.

Construction document notes shall clearly indicate provisions for *commissioning* and completion requirements in accordance with this section and are permitted to refer to specifications for further requirements. Copies of all documentation shall be given to the owner or owner’s authorized agent and made available to the *code official* upon request in accordance with Sections C408.2.4 and C408.2.5.

Exceptions: The following systems are exempt:

1. Mechanical systems and service water heater systems in buildings where the total mechanical equipment capacity is less than 480,000 Btu/h (140.7 kW)

cooling capacity and 600,000 Btu/h (175.8 kW) combined service water-heating and space-heating capacity.

2. Systems included in Section C403.5 that serve individual *dwelling units* and *sleeping units*.

C408.2.1 Commissioning plan. A *commissioning plan* shall be developed by a *registered design professional* or *approved agency* and shall include the following items:

1. A narrative description of the activities that will be accomplished during each phase of *commissioning*, including the personnel intended to accomplish each of the activities.
2. A listing of the specific equipment, appliances or systems to be tested and a description of the tests to be performed.
3. Functions to be tested including, but not limited to, calibrations and economizer controls.
4. Conditions under which the test will be performed. Testing shall affirm winter and summer design conditions and full outside air conditions.
5. Measurable criteria for performance.

C408.2.2 Systems adjusting and balancing. HVAC systems shall be balanced in accordance with generally accepted engineering standards. Air and water flow rates shall be measured and adjusted to deliver final flow rates within the tolerances provided in the product specifications. Test and balance activities shall include air system and hydronic system balancing.

C408.2.2.1 Air systems balancing. Each supply air outlet and *zone* terminal device shall be equipped with means for air balancing in accordance with the requirements of Chapter 6 of the *International Mechanical Code*. Discharge dampers used for air-system balancing are prohibited on constant-volume fans and variable-volume fans with motors 10 hp (18.6 kW) and larger.

Project Information: _____ Project Name: _____

Project Address: _____

Commissioning Authority: _____

Commissioning Plan (Section C408.2.1)

- Commissioning Plan was used during construction and includes all items required by Section C408.2.1
- Systems Adjusting and Balancing has been completed.
- HVAC Equipment Functional Testing has been executed. If applicable, deferred and follow-up testing is scheduled to be provided on: _____
- HVAC Controls Functional Testing has been executed. If applicable, deferred and follow-up testing is scheduled to be provided on: _____
- Economizer Functional Testing has been executed. If applicable, deferred and follow-up testing is scheduled to be provided on: _____
- Lighting Controls Functional Testing has been executed. If applicable, deferred and follow-up testing is scheduled to be provided on: _____
- Service Water Heating System Functional Testing has been executed. If applicable, deferred and follow-up testing is scheduled to be provided on: _____
- Manual, record documents and training have been completed or scheduled
- Preliminary Commissioning Report submitted to owner and includes all items required by Section C408.2.4

I hereby certify that the commissioning provider has provided me with evidence of mechanical, service water heating and lighting systems commissioning in accordance with the 2018 IECC.

Signature of Building Owner or Owner’s Representative _____ Date _____

**FIGURE C408.2.4
COMMISSIONING COMPLIANCE CHECKLIST**

CHAPTER 5 [CE]

EXISTING BUILDINGS

User note:

About this chapter: Many buildings are renovated or altered in numerous ways that could affect the energy use of the building as a whole. Chapter 5 requires the application of certain parts of Chapter 4 in order to maintain, if not improve, the conservation of energy by the renovated or altered building.

SECTION C501 GENERAL

C501.1 Scope. The provisions of this chapter shall control the *alteration, repair, addition* and *change of occupancy* of existing buildings and structures.

C501.2 Existing buildings. Except as specified in this chapter, this code shall not be used to require the removal, *alteration* or abandonment of, nor prevent the continued use and maintenance of, an existing *building* or *building system* lawfully in existence at the time of adoption of this code.

C501.3 Maintenance. *Buildings* and structures, and parts thereof, shall be maintained in a safe and sanitary condition. Devices and systems required by this code shall be maintained in conformance to the code edition under which they were installed. The owner or the owner's authorized agent shall be responsible for the maintenance of buildings and structures. The requirements of this chapter shall not provide the basis for removal or abrogation of energy conservation, fire protection and safety systems and devices in existing structures.

C501.4 Compliance. *Alterations, repairs, additions* and changes of occupancy to, or relocation of, existing *buildings* and structures shall comply with the provisions for *alterations, repairs, additions* and changes of occupancy or relocation, respectively, in this code and in the *International Building Code, International Existing Building Code, International Fire Code, International Fuel Gas Code, International Mechanical Code, International Plumbing Code, International Property Maintenance Code, International Private Sewage Disposal Code* and NFPA 70.

C501.5 New and replacement materials. Except as otherwise required or permitted by this code, materials permitted by the applicable code for new construction shall be used. Like materials shall be permitted for *repairs*, provided that hazards to life, health or property are not created. Hazardous materials shall not be used where the code for new construction would not allow use of these materials in buildings of similar occupancy, purpose and location.

C501.6 Historic buildings. Provisions of this code relating to the construction, *repair, alteration, restoration* and movement of structures, and *change of occupancy* shall not be mandatory for *historic buildings* provided that a report has been submitted to the *code official* and signed by a *registered design professional*, or a representative of the State Historic Preservation Office or the historic preservation authority hav-

ing jurisdiction, demonstrating that compliance with that provision would threaten, degrade or destroy the historic form, fabric or function of the *building*.

SECTION C502 ADDITIONS

C502.1 General. *Additions* to an existing *building, building system* or portion thereof shall conform to the provisions of this code as those provisions relate to new construction without requiring the unaltered portion of the existing *building* or *building system* to comply with this code. *Additions* shall not create an unsafe or hazardous condition or overload existing *building systems*. An *addition* shall be deemed to comply with this code if the *addition* alone complies or if the existing *building* and *addition* comply with this code as a single building. *Additions* shall comply with Sections C402, C403, C404, C405 and C502.2.

Additions complying with ANSI/ASHRAE/IESNA 90.1 need not comply with Sections C402, C403, C404 and C405.

C502.2 Prescriptive compliance. *Additions* shall comply with Sections C502.2.1 through C502.2.6.2.

C502.2.1 Vertical fenestration. New *vertical fenestration* area that results in a total building *fenestration* area less than or equal to that specified in Section C402.4.1 shall comply with Section C402.1.5, C402.4.3 or C407. *Additions* with *vertical fenestration* that result in a total building *fenestration* area greater than Section C402.4.1 or *additions* that exceed the fenestration area greater than Section C402.4.1 shall comply with Section C402.4.1.1 for the *addition* only. *Additions* that result in a total building vertical fenestration area exceeding that specified in Section C402.4.1.1 shall comply with Section C402.1.5 or C407

C502.2.2 Skylight area. New *skylight* area that results in a total building *fenestration* area less than or equal to that specified in Section C402.4.1 shall comply with Section C402.1.5 or C407. *Additions* with *skylight* area that result in a total building *skylight* area greater than C402.4.1 or additions that exceed the *skylight* area shall comply with Section C402.4.1.2 for the *addition* only. *Additions* that result in a total building *skylight* area exceeding that specified in Section C402.4.1.2 shall comply with Section C402.1.5 or C407.

C502.2.3 Building mechanical systems. New mechanical systems and equipment that are part of the *addition* and

EXISTING BUILDINGS

serve the building heating, cooling and ventilation needs shall comply with Section C403.

C502.2.4 Service water-heating systems. New service water-heating equipment, controls and service water heating piping shall comply with Section C404.

C502.2.5 Pools and inground permanently installed spas. New pools and inground permanently installed spas shall comply with Section C404.10.

C502.2.6 Lighting power and systems. New lighting systems that are installed as part of the addition shall comply with Section C405.

C502.2.6.1 Interior lighting power. The total interior lighting power for the *addition* shall comply with Section C405.3.2 for the *addition* alone, or the existing building and the *addition* shall comply as a single building.

C502.2.6.2 Exterior lighting power. The total exterior lighting power for the *addition* shall comply with Section C405.4.2 for the *addition* alone, or the existing building and the *addition* shall comply as a single building.

SECTION C503 ALTERATIONS

C503.1 General. *Alterations* to any *building* or structure shall comply with the requirements of Section C503 and the code for new construction. *Alterations* shall be such that the existing *building* or structure is not less conforming to the provisions of this code than the existing *building* or structure was prior to the *alteration*. *Alterations* to an existing *building*, *building* system or portion thereof shall conform to the provisions of this code as those provisions relate to new construction without requiring the unaltered portions of the existing *building* or *building* system to comply with this code. *Alterations* shall not create an unsafe or hazardous condition or overload existing *building* systems.

Alterations complying with ANSI/ASHRAE/IESNA 90.1 need not comply with Sections C402, C403, C404 and C405.

Exception: The following *alterations* need not comply with the requirements for new construction, provided that the energy use of the building is not increased:

1. Storm windows installed over existing *fenestration*.
2. Surface-applied window film installed on existing single-pane *fenestration* assemblies reducing solar heat gain, provided that the code does not require the glazing or *fenestration* to be replaced.
3. Existing ceiling, wall or floor cavities exposed during construction, provided that these cavities are filled with insulation.
4. Construction where the existing roof, wall or floor cavity is not exposed.
5. *Roof recover*.
6. *Air barriers* shall not be required for *roof recover* and roof replacement where the *alterations* or renovations to the building do not include *alterations*, renovations or *repairs* to the remainder of the building envelope.

ations to the building do not include *alterations*, renovations or *repairs* to the remainder of the building envelope.

C503.2 Change in space conditioning. Any nonconditioned or low-energy space that is altered to become *conditioned space* shall be required to be brought into full compliance with this code.

Exceptions:

1. Where the component performance alternative in Section C402.1.5 is used to comply with this section, the proposed UA shall be not greater than 110 percent of the target UA.
2. Where the total building performance option in Section C407 is used to comply with this section, the annual energy cost of the proposed design shall be not greater than 110 percent of the annual energy cost otherwise permitted by Section C407.3.

C503.3 Building envelope. New building envelope assemblies that are part of the *alteration* shall comply with Sections C402.1 through C402.5.

Exception: Where the existing building exceeds the fenestration area limitations of Section C402.4.1 prior to alteration, the building is exempt from Section C402.4.1 provided that there is not an increase in fenestration area.

C503.3.1 Roof replacement. *Roof replacements* shall comply with Section C402.1.3, C402.1.4, C402.1.5 or C407 where the existing roof assembly is part of the *building thermal envelope* and contains insulation entirely above the roof deck.

C503.3.2 Vertical fenestration. The addition of *vertical fenestration* that results in a total building *fenestration* area less than or equal to that specified in Section C402.4.1 shall comply with Section C402.1.5, C402.4.3 or C407. The addition of *vertical fenestration* that results in a total building *fenestration* area greater than Section C402.4.1 shall comply with Section C402.4.1.1 for the space adjacent to the new fenestration only. *Alterations* that result in a total building *vertical fenestration* area exceeding that specified in Section C402.4.1.1 shall comply with Section C402.1.5 or C407. Provided that the vertical fenestration area is not changed, using the same vertical fenestration area in the *standard reference design* as the building prior to alteration shall be an alternative to using the vertical fenestration area specified in Table C407.5.1(1).

C503.3.3 Skylight area. New *skylight* area that results in a total building *skylight* area less than or equal to that specified in Section C402.4.1 shall comply with Section C402.1.5, C402.4 or C407. The addition of *skylight* area that results in a total building *skylight* area greater than Section C402.4.1 shall comply with Section C402.4.1.2 for the space adjacent to the new skylights. *Alterations* that result in a total building *skylight* area exceeding that specified in Section C402.4.1.2 shall comply with Section C402.1.5 or C407. Provided that the skylight area is not changed, using the same skylight area in the *standard reference design* as the building prior to alteration shall be an

alternative to using the skylight area specified in Table C407.5.1(1).

C503.4 Heating and cooling systems. New heating, cooling and duct systems that are part of the *alteration* shall comply with Sections C403.

C503.4.1 Economizers. New cooling systems that are part of *alteration* shall comply with Section C403.5.

C503.5 Service hot water systems. New service hot water systems that are part of the *alteration* shall comply with Section C404.

C503.6 Lighting systems. New lighting systems that are part of the *alteration* shall comply with Section C405.

Exception. *Alterations* that replace less than 10 percent of the luminaires in a space, provided that such *alterations* do not increase the installed interior lighting power.

SECTION C504 REPAIRS

C504.1 General. *Buildings* and structures, and parts thereof, shall be repaired in compliance with Section C501.3 and this section. Work on nondamaged components that is necessary for the required *repair* of damaged components shall be considered to be part of the *repair* and shall not be subject to the requirements for *alterations* in this chapter. Routine maintenance required by Section C501.3, ordinary *repairs* exempt from *permit* and abatement of wear due to normal service conditions shall not be subject to the requirements for *repairs* in this section.

Where a building was constructed to comply with ANSI/ASHRAE/IESNA 90.1, repairs shall comply with the standard and need not comply with Sections C402, C403, C404 and C405.

C504.2 Application. For the purposes of this code, the following shall be considered to be repairs:

1. Glass-only replacements in an existing sash and frame.
2. *Roof repairs*.
3. Air barriers shall not be required for *roof repair* where the repairs to the building do not include *alterations*, renovations or *repairs* to the remainder of the building envelope.
4. Replacement of existing doors that separate conditioned space from the exterior shall not require the installation of a vestibule or revolving door, provided that an existing vestibule that separates a conditioned space from the exterior shall not be removed.
5. *Repairs* where only the bulb, the ballast or both within the existing luminaires in a space are replaced, provided that the replacement does not increase the installed interior lighting power.

SECTION C505 CHANGE OF OCCUPANCY OR USE

C505.1 General. Spaces undergoing a change in occupancy that would result in an increase in demand for either fossil fuel or electrical energy shall comply with this code. Where

the use in a space changes from one use in Table C405.3.2(1) or C405.3.2(2) to another use in Table C405.3.2(1) or C405.3.2(2), the installed lighting wattage shall comply with Section C405.3. Where the space undergoing a change in occupancy or use is in a building with a fenestration area that exceeds the limitations of Section C402.4.1, the space is exempt from Section C402.4.1 provided that there is not an increase in fenestration area.

Exceptions:

1. Where the component performance alternative in Section C402.1.5 is used to comply with this section, the proposed UA shall be not greater than 110 percent of the target UA.
2. Where the total building performance option in Section C407 is used to comply with this section, the annual energy cost of the proposed design shall be not greater than 110 percent of the annual energy cost otherwise permitted by Section C407.3.

CHAPTER 6 [CE]

REFERENCED STANDARDS

User note:

About this chapter: Chapter 6 lists the full title, edition year and address of the promulgator for all standards that are referenced in the code. The section numbers in which the standards are referenced are also listed.

This chapter lists the standards that are referenced in various sections of this document. The standards are listed herein by the promulgating agency of the standard, the standard identification, the effective date and title, and the section or sections of this document that reference the standard. The application of the referenced standards shall be as specified in Section 107.

AAMA

American Architectural Manufacturers Association
1827 Walden Office Square
Suite 550
Schaumburg, IL 60173-4268

AAMA/WDMA/CSA 101/I.S.2/A C440—17: North American Fenestration Standard/Specifications for Windows, Doors and Unit Skylights

Table C402.5.2

AHAM

Association of Home Appliance Manufacturers
1111 19th Street NW, Suite 402
Washington, DC 20036

ANSI/AHAM RAC-1—2008: Room Air Conditioners

Table C403.3.2(3)

AHAM HRF-1—2016: Energy, Performance and Capacity of Household Refrigerators, Refrigerator-Freezers and Freezers

Table C403.10.1

AHRI

Air-Conditioning, Heating, & Refrigeration Institute
2111 Wilson Blvd, Suite 500
Arlington, VA 22201

ISO/AHRI/ASHRAE 13256-1 (2017): Water-to-Air and Brine-to-Air Heat Pumps—Testing and Rating for Performance

Table C403.3.2(2)

ISO/AHRI/ASHRAE 13256-2 (2017): Water-to-Water and Brine-to-Water Heat Pumps —Testing and Rating for Performance

Table C403.3.2(2)

210/240—2016: Performance Rating of Unitary Air-conditioning and Air-source Heat Pump Equipment

Table C403.3.2(1), Table C403.3.2(2)

310/380—2014 (CSA-C744-04): Standard for Packaged Terminal Air Conditioners and Heat Pumps

Table C403.3.2(3)

340/360—2015: Performance Rating of Commercial and Industrial Unitary Air-conditioning and Heat Pump Equipment

Table C403.3.2(1), Table C403.3.2(2)

365(I-P)—2009: Commercial and Industrial Unitary Air-conditioning Condensing Units

Table C403.3.2(1), Table C403.3.2(6)

390 (I-P)—2015: Performance Rating of Single Package Vertical Air-conditioners and Heat Pumps

Table C403.3.2(3)

400 (I-P)—2015: Performance Rating of Liquid to Liquid Heat Exchangers

Table C403.3.2(10)

440—2008: Performance Rating of Room Fan Coils—with Addendum 1

C403.11.3

460—2005: Performance Rating of Remote Mechanical-draft Air-cooled Refrigerant Condensers

Table C403.3.2(8)

REFERENCED STANDARDS

AHRI—continued

- 550/590 (I-P)—2015: Performance Rating of Water-chilling and Heat Pump Water-heating Packages Using the Vapor Compression Cycle**
C403.3.2.1, Table C403.3.2(7)
- 560—00: Absorption Water Chilling and Water Heating Packages**
Table C403.3.2(7)
- 1160 (I-P)—2014: Performance Rating of Heat Pump Pool Heaters**
Table C404.2
- 1200 (I-P)—2013: Performance Rating of Commercial Refrigerated Display Merchandisers and Storage Cabinets**
C403.10, Table C403.10.1(1), Table C403.10.1(2)

AMCA

Air Movement and Control Association International
30 West University Drive
Arlington Heights, IL 60004-1806

- 205—12: Energy Efficiency Classification for Fans**
C403.8.3
- 220—08 (R2012): Laboratory Methods of Testing Air Curtain Units for Aerodynamic Performance Rating**
C402.5.6
- 500D—12: Laboratory Methods for Testing Dampers for Rating**
C403.7.7

ANSI

American National Standards Institute
25 West 43rd Street, 4th Floor
New York, NY 10036

- Z21.10.3/CSA 4.3—11: Gas Water Heaters, Volume III—Storage Water Heaters with Input Ratings Above 75,000 Btu per Hour, Circulating Tank and Instantaneous**
Table C404.2
- Z21.47/CSA 2.3—12: Gas-fired Central Furnaces**
Table C403.3.2(4)
- Z83.8/CSA 2.6—09: Gas Unit Heaters, Gas Packaged Heaters, Gas Utility Heaters and Gas-fired Duct Furnaces**
Table C403.3.2(4)

APSP

The Association of Pool & Spa Professionals
2111 Eisenhower Avenue, Suite 580
Alexandria, VA 22314

- 14—2014: American National Standard for Portable Electric Spa Energy Efficiency**
C404.8

ASHRAE

ASHRAE
1791 Tullie Circle NE
Atlanta, GA 30329

- ASHRAE 127-2007: Method of Testing for Rating Computer**
Table C403.3.2(9)
- ANSI/ASHRAE/ACCA Standard 183—2007 (RA2014): Peak Cooling and Heating Load Calculations in Buildings, Except Low-rise Residential Buildings**
C403.1.1
- ASHRAE—2016: ASHRAE HVAC Systems and Equipment Handbook**
C403.1.1
- ISO/AHRI/ASHRAE 13256-1 (2017): Water-to-Air and Brine-to-Air Heat Pumps—Testing and Rating for Performance**
Table C403.3.2(2)
- ISO/AHRI/ASHRAE 13256-2 (2017): Water-to-Water and Brine-to-Water Heat Pumps—Testing and Rating for Performance**
Table C403.3.2(2)

ASHRAE—continued

- 55—2013: Thermal Environmental Conditions for Human Occupancy**
Table C407.5.1
- 90.1—2016: Energy Standard for Buildings Except Low-rise Residential Buildings**
C401.2, Table C402.1.3, Table C402.1.4, C406.2, Table C407.6.1, C502.1, C503.1, C504.1
- 140—2014: Standard Method of Test for the Evaluation of Building Energy Analysis Computer Programs**
C407.6.1
- 146—2011: Testing and Rating Pool Heaters**
Table C404.2

ASME

American Society of Mechanical Engineers
Two Park Avenue
New York, NY 10016-5990

- ASME A17.1—2016/CSA B44—16: Safety Code for Elevators and Escalators**
C405.8.2

ASTM

ASTM International
100 Barr Harbor Drive, P.O. Box C700
West Conshohocken, PA 19428-2959

- C90—14: Specification for Load-bearing Concrete Masonry Units**
Table C401.3
- C1363—11: Standard Test Method for Thermal Performance of Building Materials and Envelope Assemblies by Means of a Hot Box Apparatus**
C303.1.4.1, Table C402.1.4, 402.2.7
- C1371—15: Standard Test Method for Determination of Emittance of Materials Near Room Temperature Using Portable Emissometers**
Table C402.3
- C1549—09(2014): Standard Test Method for Determination of Solar Reflectance Near Ambient Temperature Using a Portable Solar Reflectometer**
Table C402.3
- D1003—13: Standard Test Method for Haze and Luminous Transmittance of Transparent Plastics**
C402.4.2.2
- E283—04(2012): Test Method for Determining the Rate of Air Leakage Through Exterior Windows, Curtain Walls and Doors Under Specified Pressure Differences Across the Specimen**
C402.5.1.2.2, Table C402.5.2, C402.5.7
- E408—13: Test Methods for Total Normal Emittance of Surfaces Using Inspection-meter Techniques**
Table C402.3
- E779—10: Standard Test Method for Determining Air Leakage Rate by Fan Pressurization**
C402.5
- E903—12: Standard Test Method Solar Absorptance, Reflectance and Transmittance of Materials Using Integrating Spheres (Withdrawn 2005)**
Table C402.3
- E1677—11: Specification for Air Barrier (AB) Material or Systems for Low-rise Framed Building Walls**
C402.5.1.2.2
- E1827—11: Standard Test Methods for Determining Airtightness of Building Using an Orifice Blower Door**
C402.5, C406.9, C606.4
- E1918—06(2015): Standard Test Method for Measuring Solar Reflectance of Horizontal or Low-sloped Surfaces in the Field**
Table C402.3
- E1980—11: Standard Practice for Calculating Solar Reflectance Index of Horizontal and Low-sloped Opaque Surfaces**
Table C402.3, C402.3.2
- E2178—13: Standard Test Method for Air Permanence of Building Materials**
C402.5.1.2.1

REFERENCED STANDARDS

ASTM—continued

E2357—11: Standard Test Method for Determining Air Leakage of Air Barriers Assemblies
C402.5.1.2.2

CRRC

Cool Roof Rating Council
449 15th Street, Suite 400
Oakland, CA 94612

ANSI/CRRC-S100—2016: Standard Test Methods for Determining Radiative Properties of Materials
Table C402.3, C402.3.1

CSA

CSA Group
8501 East Pleasant Valley Road
Cleveland, OH 44131-5516

AAMA/WDMA/CSA 101/LS.2/A440—17: North American Fenestration Standard/Specification for Windows, Doors and Unit Skylights
Table C402.5.2

CSA B55.1—2015: Test Method for Measuring Efficiency and Pressure Loss of Drain Water Heat Recovery Units
C404.8

CSA B55.2—2015: Drain Water Heat Recovery Units
C404.8

CTI

Cooling Technology Institute
P. O. Box 681807
Houston, TX 77268

ATC 105 (00): Acceptance Test Code for Water Cooling Tower
Table C403.3.2(8)

ATC 105S—11: Acceptance Test Code for Closed Circuit Cooling Towers
Table C403.3.2(8)

ATC 106—11: Acceptance Test for Mechanical Draft Evaporative Vapor Condensers
Table C403.3.2(8)

STD 201—11: Standard for Certification of Water Cooling Towers Thermal Performances
Table C403.3.2(8)

CTI STD 201 RS(15): Performance Rating of Evaporative Heat Rejection Equipment
Table C403.3.2(8)

DASMA

Door & Access Systems Manufacturers Association, International
1300 Sumner Avenue
Cleveland, OH 44115-2851

105—2016: Test Method for Thermal Transmittance and Air Infiltration of Garage Doors and Rolling Doors
C303.1.3, Table C402.5.2

DOE

U.S. Department of Energy
c/o Superintendent of Documents
1000 Independence Avenue SW
Washington, DC 20585

10 CFR, Part 430—2015: Energy Conservation Program for Consumer Products: Test Procedures and Certification and Enforcement Requirement for Plumbing Products; and Certification and Enforcement Requirements for Residential Appliances; Final Rule
Table C403.3.2(4), Table C403.3.2(5), Table C404.2

DOE—continued

- 10 CFR, Part 430, Subpart B, Appendix N—(2015): Uniform Test Method for Measuring the Energy Consumption of Furnaces and Boilers**
C202
- 10 CFR, Part 431—2015: Energy Efficiency Program for Certain Commercial and Industrial Equipment: Test Procedures and Efficiency Standards; Final Rules**
Table C403.3.2(5), C405.6, Table C405.6, C405.7
- 10 CFR 431 Subpart B App B: Uniform Test Method for Measuring Nominal Full Load Efficiency of Electric Motors**
C403.8.4, Table C405.7(1), Table C405.7(2), Table C405.7(3), C405.7(4)
- NAECA 87—(88): National Appliance Energy Conservation Act 1987 [Public Law 100-12 (with Amendments of 1988-P.L. 100-357)]**
Table C403.3.2(1), Table C403.3.2(2), Table C403.3.2(4)

ICC

International Code Council, Inc.
500 New Jersey Avenue NW
6th Floor
Washington, DC 20001

- IBC—18: International Building Code®**
C201.3, C303.2, C402.5.3, C501.4
- IFC—18: International Fire Code®**
C201.3, C501.4
- IFGC—18: International Fuel Gas Code®**
C201.3, C501.4
- IMC—18: International Mechanical Code®**
C403.7.7, C403.2.2, C403.7.1, C403.7.2, C403.7.4, C403.7.5, C403.11.1, C403.11.2.1, C403.11.2.2, C403.6, C403.6.6, C406.6, C501.4
- IPC—18: International Plumbing Code®**
C201.3, C501.4
- IPMC—18: International Property Maintenance Code®**
C501.4
- IPSDC—18: International Private Sewage Disposal Code®**
C501.4

IEEE

Institute of Electrical and Electronic Engineers
3 Park Avenue, 17th Floor
New York, NY 10016

- IEEE 515.1—2012: IEE Standard for the Testing, Design, Installation, and Maintenance of Electrical Resistance Trace Heating for Commercial Applications**
C404.6.2

IES

Illuminating Engineering Society
120 Wall Street, 17th Floor
New York, NY 10005-4001

- ANSI/ASHRAE/IESNA 90.1—2016: Energy Standard for Buildings, Except Low-rise Residential Buildings**
C401.2, Table C402.1.3, Table C402.1.4, C406.2, C502.1, C503.1, C504.1

ISO

International Organization for Standardization
Chemin de Blandonnet 8, CP 401, 1214 Vernier
Geneva, Switzerland

- ISO/AHRI/ASHRAE 13256-1(2017): Water-to-Air and Brine-to-Air Heat Pumps -Testing and Rating for Performance**
Table C403.3.2(2)
- ISO/AHRI/ASHRAE 13256-2(2017): Water-to-Water and Brine-to-Water Heat Pumps -Testing and Rating for Performance**
C403.3.2(2)

REFERENCED STANDARDS

NEMA

National Electrical Manufacturers Association
1300 North 17th Street, Suite 900
Rosslyn, VA 22209

MG1—2014: Motors and Generators
C202

NFPA

National Fire Protection Association
1 Batterymarch Park
Quincy, MA 02169-7471

70—17: National Electrical Code
C501.4

NFRC

National Fenestration Rating Council, Inc.
6305 Ivy Lane, Suite 140
Greenbelt, MD 20770

100—2017: Procedure for Determining Fenestration Products *U*-factors
C303.1.3, C402.2.1.1

200—2017: Procedure for Determining Fenestration Product Solar Heat Gain Coefficients and Visible Transmittance at Normal Incidence
C303.1.3, C402.4.1.1

400—2017: Procedure for Determining Fenestration Product Air Leakage
Table C402.5.2

SMACNA

Sheet Metal and Air Conditioning Contractors' National Association, Inc.
4021 Lafayette Center Drive
Chantilly, VA 20151-1219

SMACNA—2012: HVAC Air Duct Leakage Test Manual Second Edition
C403.2.11.2.3

UL

UL LLC
333 Pfingsten Road
Northbrook, IL 60062-2096

710—12: Exhaust Hoods for Commercial Cooking Equipment—with Revisions through November 2013
C403.7.5

727—06: Oil-fired Central Furnaces—with Revisions through October 2013
Table C403.3.2(4)

731—95: Oil-fired Unit Heaters—with Revisions through October 2013
Table C403.3.2(4)

1784—01: Air Leakage Tests of Door Assemblies—with Revisions through February 2015
C402.5.3

US-FTC

United States-Federal Trade Commission
600 Pennsylvania Avenue NW
Washington, DC 20580

CFR Title 16 (2015): R-value Rule
C303.1.4

WDMA

Window and Door Manufacturers Association
2025 M Street NW, Suite 800
Washington, DC 20036-3309

AAMA/WDMA/CSA 101/I.S.2/A440—17: North American Fenestration Standard/Specification for Windows, Doors and Unit Skylights
Table C402.5.2

APPENDIX CA

SOLAR-READY ZONE—COMMERCIAL

The provisions contained in this appendix are not mandatory unless specifically referenced in the adopting ordinance.

User note:

About this appendix: Appendix CA is intended to encourage the installation of renewable energy systems by preparing buildings for the future installation of solar energy equipment, piping and wiring.

SECTION CA101 SCOPE

CA101.1 General. These provisions shall be applicable for new construction where solar-ready provisions are required.

SECTION CA102 GENERAL DEFINITION

SOLAR-READY ZONE. A section or sections of the roof or building overhang designated and reserved for the future installation of a solar photovoltaic or solar thermal system.

SECTION CA103 SOLAR-READY ZONE

CA103.1 General. A solar-ready zone shall be located on the roof of buildings that are five stories or less in height above grade plane, and are oriented between 110 degrees and 270 degrees of true north or have low-slope roofs. Solar-ready zones shall comply with Sections CA103.2 through CA103.8.

Exceptions:

1. A building with a permanently installed, on-site renewable energy system.
2. A building with a solar-ready zone that is shaded for more than 70 percent of daylight hours annually.
3. A building where the licensed design professional certifies that the incident solar radiation available to the building is not suitable for a solar-ready zone.
4. A building where the licensed design professional certifies that the solar zone area required by Section CA103.3 cannot be met because of extensive rooftop equipment, skylights, vegetative roof areas or other obstructions.

CA103.2 Construction document requirements for a solar-ready zone. Construction documents shall indicate the solar-ready zone.

CA103.3 Solar-ready zone area. The total solar-ready zone area shall be not less than 40 percent of the roof area calculated as the horizontally projected gross roof area less the area covered by skylights, occupied roof decks, vegetative roof areas and mandatory *access* or set back areas as required by the *International Fire Code*. The solar-ready zone shall be a single area or smaller, separated sub-zone areas. Each sub-

zone shall be not less than 5 feet (1524 mm) in width in the narrowest dimension.

CA103.4 Obstructions. Solar ready zones shall be free from obstructions, including pipes, vents, ducts, HVAC equipment, skylights and roof-mounted equipment.

CA103.5 Roof loads and documentation. A collateral dead load of not less than 5 pounds per square foot (5 psf) (24.41 kg/m²) shall be included in the gravity and lateral design calculations for the solar-ready zone. The structural design loads for roof dead load and roof live load shall be indicated on the construction documents.

CA103.6 Interconnection pathway. Construction documents shall indicate pathways for routing of conduit or piping from the solar-ready zone to the electrical service panel or service hot water system.

CA103.7 Electrical service reserved space. The main electrical service panel shall have a reserved space to allow installation of a dual-pole circuit breaker for future solar electric installation and shall be labeled "For Future Solar Electric." The reserved space shall be positioned at the end of the panel that is opposite from the panel supply conductor connection.

CA103.8 Construction documentation certificate. A permanent certificate, indicating the solar-ready zone and other requirements of this section, shall be posted near the electrical distribution panel, water heater or other conspicuous location by the builder or registered design professional.

INDEX

A

ACCESSIBLE

Controls C402.2.3, C404.6, C404.9.1,
C405.2.2.3, C405.2.3.1

Defined C202

ADDITIONAL EFFICIENCY PACKAGE C406

ADDITIONS

Defined C202

Historic buildings C501.6

Requirements C502

ADMINISTRATION Chapter 1

AIR BARRIER C402.5

Access openings C402.5.4

Assemblies C402.5.1.2.2

Compliance options C402.5.1.2

Construction C402.5.1.1

Dampers C402.5.5, C403.7.7

Doors other than fenestration C402.5.4

Fenestration C402.5.2, Table C402.5.2

Materials C402.5.1.2.1

Penetrations C402.5.1.1

Recessed lighting C402.5.8

Rooms with fuel burning appliances C402.5.3

Testing C402.5

Vestibules C402.5.7

AIR CONDITIONERS

Efficiency requirements Tables C403.3.2(1, 3)

AIR CURTAIN

Defined C202

Vestibules C402.5.7

AIR ECONOMIZERS

Defined C202

Requirements C403.5, C403.5.1, C403.5.2,
C403.5.3, C403.5.4

AIR INFILTRATION (see AIR BARRIER)

Defined C202

AIR INTAKES AND EXHAUSTS C402.5.5,
C403.7.7

AIR LEAKAGE—THERMAL ENVELOPE (see AIR BARRIER)

AIR SYSTEM BALANCING C408.2.2.1,
C408.2.2.2, C408.2.5.3

ALTERATIONS

Defined C202

Historic buildings C501.6

Replacement fenestration C401.2.1

Requirements C503

ALTERNATE MATERIALS C102

APPROVED

Defined C202

APPROVED AGENCY

Defined C202

Inspections C105.4

AREA-WEIGHTED U-FACTOR C402.4.3.4

AUTOMATIC

Defined C202

B

BASEMENT WALLS (see WALL, BELOW GRADE)

Requirements C303.2.1

BELOW-GRADE WALLS (see WALL, BELOW GRADE)

BOARD OF APPEALS C109

Limitations on authority C109.2

Qualifications of members C109.3

BOILERS

Defined C202

Requirements Table C403.3.2(5), C403.3.4,
C403.4.3, C404.2, Table C404.2

Setback controls C403.4.1.5

Turndown controls C403.3.4

BUILDING

Defined C202

Multifamily residential C407.5.2.3

BUILDING COMMISSIONING

Defined C202

Requirements C408

BUILDING ENTRANCE

Defined C202

Exterior lighting Table C405.4.2(2)

Lighting controls C405.2.1.1

Vestibules C402.5.7

BUILDING ENVELOPE

Compliance documentation C103.2, C103.2.1

Defined C202

Exemptions C402.1.1, C402.1.2

Insulation C303.1.1

Insulation and
fenestration criteria C402.1.3, Table C402.1.3,
C402.1.4, Table C402.1.4

Requirements C402

Performance method C407.3

BUILDING THERMAL ENVELOPE

Air leakage and barriers C402.5

Defined C202

Doors C402.4.5

IECC—RESIDENTIAL PROVISIONS

TABLE OF CONTENTS

CHAPTER 1 SCOPE AND ADMINISTRATION	R-3	CHAPTER 5 EXISTING BUILDINGS	R-45
PART 1—SCOPE AND APPLICATION	R-3	Section	
Section		R501 General	R-45
R101 Scope and General Requirements	R-3	R502 Additions	R-45
R102 Alternative Materials, Design and Methods of Construction and Equipment	R-3	R503 Alterations	R-46
		R504 Repairs	R-46
		R505 Change of Occupancy or Use	R-47
PART 2—ADMINISTRATION AND ENFORCEMENT	R-3	CHAPTER 6 REFERENCED STANDARDS	R-49
R103 Construction Documents	R-3	APPENDIX RA SOLAR-READY PROVISIONS—DETACHED ONE- AND TWO-FAMILY DWELLINGS AND TOWNHOUSES	R-53
R104 Fees	R-4	Section	
R105 Inspections	R-4	RA101 Scope	R-53
R106 Validity	R-5	RA102 General Definition	R-53
R107 Referenced Standards	R-5	RA103 Solar-ready Zone	R-53
R108 Stop Work Order	R-5		
R109 Board of Appeals	R-6	INDEX	R-55
CHAPTER 2 DEFINITIONS	R-7		
Section			
R201 General	R-7		
R202 General Definitions	R-7		
CHAPTER 3 GENERAL REQUIREMENTS	R-11		
Section			
R301 Climate Zones	R-11		
R302 Design Conditions	R-26		
R303 Materials, Systems and Equipment	R-26		
CHAPTER 4 RESIDENTIAL ENERGY EFFICIENCY	R-29		
Section			
R401 General	R-29		
R402 Building Thermal Envelope	R-29		
R403 Systems	R-35		
R404 Electrical Power and Lighting Systems	R-37		
R405 Simulated Performance Alternative (Performance)	R-37		
R406 Energy Rating Index Compliance Alternative	R-42		

CHAPTER 1 [RE]

SCOPE AND ADMINISTRATION

User note:

About this chapter: Chapter 1 establishes the limits of applicability of this code and describes how the code is to be applied and enforced. Chapter 1 is in two parts: Part 1—Scope and Application (Sections 101–102) and Part 2—Administration and Enforcement (Sections 103–109). Section 101 identifies which buildings and structures come under its purview and references other I-Codes as applicable. Standards and codes are scoped to the extent referenced (see Section 107.1).

This code is intended to be adopted as a legally enforceable document, and it cannot be effective without adequate provisions for its administration and enforcement. The provisions of Chapter 1 establish the authority and duties of the code official appointed by the authority having jurisdiction and also establish the rights and privileges of the design professional, contractor and property owner.

PART 1—SCOPE AND APPLICATION

SECTION R101 SCOPE AND GENERAL REQUIREMENTS

R101.1 Title. This code shall be known as the *Energy Conservation Code* of [NAME OF JURISDICTION], and shall be cited as such. It is referred to herein as “this code.”

R101.2 Scope. This code applies to *residential buildings* and the *building* sites and associated systems and equipment.

R101.3 Intent. This code shall regulate the design and construction of *buildings* for the effective use and conservation of energy over the useful life of each building. This code is intended to provide flexibility to permit the use of innovative approaches and techniques to achieve this objective. This code is not intended to abridge safety, health or environmental requirements contained in other applicable codes or ordinances.

R101.4 Applicability. Where, in any specific case, different sections of this code specify different materials, methods of construction or other requirements, the most restrictive shall govern. Where there is a conflict between a general requirement and a specific requirement, the specific requirement shall govern.

R101.4.1 Mixed residential and commercial buildings. Where a *building* includes both *residential* building and *commercial building* portions, each portion shall be separately considered and meet the applicable provisions of the IECC—Commercial Provisions or IECC—Residential Provisions.

R101.5 Compliance. *Residential buildings* shall meet the provisions of IECC—Residential Provisions. *Commercial buildings* shall meet the provisions of IECC—Commercial Provisions.

R101.5.1 Compliance materials. The *code official* shall be permitted to approve specific computer software, worksheets, compliance manuals and other similar materials that meet the intent of this code.

SECTION R102 ALTERNATIVE MATERIALS, DESIGN AND METHODS OF CONSTRUCTION AND EQUIPMENT

R102.1 General. The provisions of this code are not intended to prevent the installation of any material or to prohibit any design or method of construction not specifically prescribed by this code. The *code official* shall have the authority to approve an alternative material, design or method of construction upon application of the owner or the owner’s authorized agent. The *code official* shall first find that the proposed design is satisfactory and complies with the intent of the provisions of this code, and that the material, method or work offered is, for the purpose intended, not less than the equivalent of that prescribed in this code for strength, effectiveness, fire resistance, durability and safety. Where the alternative material, design or method of construction is not *approved*, the *code official* shall respond to the applicant, in writing, stating the reasons why the alternative was not *approved*.

R102.1.1 Above code programs. The *code official* or other authority having jurisdiction shall be permitted to deem a national, state or local energy-efficiency program to exceed the energy efficiency required by this code. *Buildings approved* in writing by such an energy-efficiency program shall be considered to be in compliance with this code. The requirements identified as “mandatory” in Chapter 4 shall be met.

PART 2—ADMINISTRATION AND ENFORCEMENT

SECTION R103 CONSTRUCTION DOCUMENTS

R103.1 General. Construction documents, technical reports and other supporting data shall be submitted in one or more sets with each application for a permit. The construction documents and technical reports shall be prepared by a registered design professional where required by the statutes of the jurisdiction in which the project is to be constructed. Where special conditions exist, the *code official* is authorized to require necessary construction documents to be prepared by a registered design professional.

Exception: The *code official* is authorized to waive the requirements for construction documents or other support-

SCOPE AND ADMINISTRATION

ing data if the *code official* determines they are not necessary to confirm compliance with this code.

R103.2 Information on construction documents. Construction documents shall be drawn to scale on suitable material. Electronic media documents are permitted to be submitted where *approved* by the *code official*. Construction documents shall be of sufficient clarity to indicate the location, nature and extent of the work proposed, and show in sufficient detail pertinent data and features of the *building*, systems and equipment as herein governed. Details shall include the following as applicable:

1. Insulation materials and their *R*-values.
2. Fenestration *U*-factors and *solar heat gain coefficients* (SHGC).
3. Area-weighted *U*-factor and *solar heat gain coefficients* (SHGC) calculations.
4. Mechanical system design criteria.
5. Mechanical and service water-heating systems and equipment types, sizes and efficiencies.
6. Equipment and system controls.
7. Duct sealing, duct and pipe insulation and location.
8. Air sealing details.

R103.2.1 Building thermal envelope depiction. The *building thermal envelope* shall be represented on the construction documents.

R103.3 Examination of documents. The *code official* shall examine or cause to be examined the accompanying construction documents and shall ascertain whether the construction indicated and described is in accordance with the requirements of this code and other pertinent laws or ordinances. The *code official* is authorized to utilize a registered design professional, or other *approved* entity not affiliated with the building design or construction, in conducting the review of the plans and specifications for compliance with the code.

R103.3.1 Approval of construction documents. When the *code official* issues a permit where construction documents are required, the construction documents shall be endorsed in writing and stamped “Reviewed for Code Compliance.” Such *approved* construction documents shall not be changed, modified or altered without authorization from the *code official*. Work shall be done in accordance with the *approved* construction documents.

One set of construction documents so reviewed shall be retained by the *code official*. The other set shall be returned to the applicant, kept at the site of work and shall be open to inspection by the *code official* or a duly authorized representative.

R103.3.2 Previous approvals. This code shall not require changes in the construction documents, construction or designated occupancy of a structure for which a lawful permit has been heretofore issued or otherwise lawfully authorized, and the construction of which has been pur-

sued in good faith within 180 days after the effective date of this code and has not been abandoned.

R103.3.3 Phased approval. The *code official* shall have the authority to issue a permit for the construction of part of an energy conservation system before the construction documents for the entire system have been submitted or *approved*, provided adequate information and detailed statements have been filed complying with all pertinent requirements of this code. The holders of such permit shall proceed at their own risk without assurance that the permit for the entire energy conservation system will be granted.

R103.4 Amended construction documents. Work shall be installed in accordance with the *approved* construction documents, and any changes made during construction that are not in compliance with the *approved* construction documents shall be resubmitted for approval as an amended set of construction documents.

R103.5 Retention of construction documents. One set of *approved* construction documents shall be retained by the *code official* for a period of not less than 180 days from date of completion of the permitted work, or as required by state or local laws.

SECTION R104 FEES

R104.1 Fees. A permit shall not be issued until the fees prescribed in Section R104.2 have been paid, nor shall an amendment to a permit be released until the additional fee, if any, has been paid.

R104.2 Schedule of permit fees. A fee for each permit shall be paid as required, in accordance with the schedule as established by the applicable governing authority.

R104.3 Work commencing before permit issuance. Any person who commences any work before obtaining the necessary permits shall be subject to an additional fee established by the *code official* that shall be in addition to the required permit fees.

R104.4 Related fees. The payment of the fee for the construction, *alteration*, removal or demolition of work done in connection to or concurrently with the work or activity authorized by a permit shall not relieve the applicant or holder of the permit from the payment of other fees that are prescribed by law.

R104.5 Refunds. The *code official* is authorized to establish a refund policy.

SECTION R105 INSPECTIONS

R105.1 General. Construction or work for which a permit is required shall be subject to inspection by the *code official* or his or her designated agent, and such construction or work shall remain visible and able to be accessed for inspection purposes until *approved*. It shall be the duty of the permit applicant to cause the work to remain visible and able to be accessed for inspection purposes. Neither the *code official*

nor the jurisdiction shall be liable for expense entailed in the removal or replacement of any material, product, system or building component required to allow inspection to validate compliance with this code.

R105.2 Required inspections. The *code official* or his or her designated agent, upon notification, shall make the inspections set forth in Sections R105.2.1 through R105.2.5.

R105.2.1 Footing and foundation inspection. Inspections associated with footings and foundations shall verify compliance with the code as to *R-value*, location, thickness, depth of burial and protection of insulation as required by the code and *approved* plans and specifications.

R105.2.2 Framing and rough-in inspection. Inspections at framing and rough-in shall be made before application of interior finish and shall verify compliance with the code as to: types of insulation and corresponding *R-values* and their correct location and proper installation; fenestration properties such as *U-factor* and SHGC and proper installation; and air leakage controls as required by the code; and approved plans and specifications.

R105.2.3 Plumbing rough-in inspection. Inspections at plumbing rough-in shall verify compliance as required by the code and *approved* plans and specifications as to types of insulation and corresponding *R-values* and protection, and required controls.

R105.2.4 Mechanical rough-in inspection. Inspections at mechanical rough-in shall verify compliance as required by the code and *approved* plans and specifications as to installed HVAC equipment type and size, required controls, system insulation and corresponding *R-value*, system air leakage control, programmable thermostats, dampers, whole-house ventilation, and minimum fan efficiency.

Exception: Systems serving multiple dwelling units shall be inspected in accordance with Section C105.2.4.

R105.2.5 Final inspection. The *building* shall have a final inspection and shall not be occupied until *approved*. The final inspection shall include verification of the installation of all required *building* systems, equipment and controls and their proper operation and the required number of high-efficacy lamps and fixtures.

R105.3 Reinspection. A *building* shall be reinspected where determined necessary by the *code official*.

R105.4 Approved inspection agencies. The *code official* is authorized to accept reports of third-party inspection agencies not affiliated with the *building* design or construction, provided that such agencies are *approved* as to qualifications and reliability relevant to the *building* components and systems that they are inspecting.

R105.5 Inspection requests. It shall be the duty of the holder of the permit or their duly authorized agent to notify the *code official* when work is ready for inspection. It shall be the duty of the permit holder to provide access to and means for inspections of such work that are required by this code.

R105.6 Reinspection and testing. Where any work or installation does not pass an initial test or inspection, the necessary corrections shall be made to achieve compliance with this code. The work or installation shall then be resubmitted to the *code official* for inspection and testing.

R105.7 Approval. After the prescribed tests and inspections indicate that the work complies in all respects with this code, a notice of approval shall be issued by the *code official*.

R105.7.1 Revocation. The *code official* is authorized to, in writing, suspend or revoke a notice of approval issued under the provisions of this code wherever the certificate is issued in error, or on the basis of incorrect information supplied, or where it is determined that the *building* or structure, premise, or portion thereof is in violation of any ordinance or regulation or any of the provisions of this code.

SECTION R106 VALIDITY

R106.1 General. If a portion of this code is held to be illegal or void, such a decision shall not affect the validity of the remainder of this code.

SECTION R107 REFERENCED STANDARDS

R107.1 Referenced codes and standards. The codes and standards referenced in this code shall be those indicated in Chapter 5, and such codes and standards shall be considered as part of the requirements of this code to the prescribed extent of each such reference and as further regulated in Sections R107.1.1 and R107.1.2.

R107.1.1 Conflicts. Where conflicts occur between provisions of this code and referenced codes and standards, the provisions of this code shall apply.

R107.1.2 Provisions in referenced codes and standards. Where the extent of the reference to a referenced code or standard includes subject matter that is within the scope of this code, the provisions of this code, as applicable, shall take precedence over the provisions in the referenced code or standard.

R107.2 Application of references. References to chapter or section numbers, or to provisions not specifically identified by number, shall be construed to refer to such chapter, section or provision of this code.

R107.3 Other laws. The provisions of this code shall not be deemed to nullify any provisions of local, state or federal law.

SECTION R108 STOP WORK ORDER

R108.1 Authority. Where the *code official* finds any work regulated by this code being performed in a manner either contrary to the provisions of this code or dangerous or unsafe, the *code official* is authorized to issue a stop work order.

SCOPE AND ADMINISTRATION

R108.2 Issuance. The stop work order shall be in writing and shall be given to the owner of the property involved, to the owner's authorized agent, or to the person doing the work. Upon issuance of a stop work order, the cited work shall immediately cease. The stop work order shall state the reason for the order and the conditions under which the cited work will be permitted to resume.

R108.3 Emergencies. Where an emergency exists, the *code official* shall not be required to give a written notice prior to stopping the work.

R108.4 Failure to comply. Any person who shall continue any work after having been served with a stop work order, except such work as that person is directed to perform to remove a violation or unsafe condition, shall be subject to a fine as set by the applicable governing authority.

SECTION R109 BOARD OF APPEALS

R109.1 General. In order to hear and decide appeals of orders, decisions or determinations made by the *code official* relative to the application and interpretation of this code, there shall be and is hereby created a board of appeals. The *code official* shall be an ex officio member of said board but shall not have a vote on any matter before the board. The board of appeals shall be appointed by the governing body and shall hold office at its pleasure. The board shall adopt rules of procedure for conducting its business, and shall render all decisions and findings in writing to the appellant with a duplicate copy to the *code official*.

R109.2 Limitations on authority. An application for appeal shall be based on a claim that the true intent of this code or the rules legally adopted thereunder have been incorrectly interpreted, the provisions of this code do not fully apply or an equally good or better form of construction is proposed. The board shall not have authority to waive requirements of this code.

R109.3 Qualifications. The board of appeals shall consist of members who are qualified by experience and training and are not employees of the jurisdiction.

CHAPTER 2 [RE] DEFINITIONS

User note:

About this chapter: Codes, by their very nature, are technical documents. Every word, term and punctuation mark can add to or change the meaning of a technical requirement. It is necessary to maintain a consensus on the specific meaning of each term contained in the code. Chapter 2 performs this function by stating clearly what specific terms mean for the purpose of the code.

SECTION R201 GENERAL

R201.1 Scope. Unless stated otherwise, the following words and terms in this code shall have the meanings indicated in this chapter.

R201.2 Interchangeability. Words used in the present tense include the future; words in the masculine gender include the feminine and neuter; the singular number includes the plural and the plural includes the singular.

R201.3 Terms defined in other codes. Terms that are not defined in this code but are defined in the *International Building Code*, *International Fire Code*, *International Fuel Gas Code*, *International Mechanical Code*, *International Plumbing Code* or the *International Residential Code* shall have the meanings ascribed to them in those codes.

R201.4 Terms not defined. Terms not defined by this chapter shall have ordinarily accepted meanings such as the context implies.

SECTION R202 GENERAL DEFINITIONS

ABOVE-GRADE WALL. A wall more than 50 percent above grade and enclosing *conditioned space*. This includes between-floor spandrels, peripheral edges of floors, roof and basement knee walls, dormer walls, gable end walls, walls enclosing a mansard roof and *skylight* shafts.

ACCESSIBLE. Admitting close approach as a result of not being guarded by locked doors, elevation or other effective means (see “*Readily accessible*”).

ADDITION. An extension or increase in the *conditioned space* floor area, number of stories or height of a building or structure.

AIR BARRIER. One or more materials joined together in a continuous manner to restrict or prevent the passage of air through the *building thermal envelope* and its assemblies.

AIR-IMPERMEABLE INSULATION. An insulation that functions as an air barrier material.

ALTERATION. Any construction, retrofit or renovation to an existing structure other than *repair* or *addition*. Also, a change in a building, electrical, gas, mechanical or plumbing system that involves an extension, addition or change to the arrangement, type or purpose of the original installation.

APPROVED. Acceptable to the *code official*.

APPROVED AGENCY. An established and recognized agency that is regularly engaged in conducting tests furnishing inspection services, or furnishing product certification, where such agency has been *approved* by the *code official*.

AUTOMATIC. Self-acting, operating by its own mechanism when actuated by some impersonal influence, as, for example, a change in current strength, pressure, temperature or mechanical configuration (see “*Manual*”).

BASEMENT WALL. A wall 50 percent or more below grade and enclosing *conditioned space*.

BUILDING. Any structure used or intended for supporting or sheltering any use or occupancy, including any mechanical systems, service water heating systems and electric power and lighting systems located on the building site and supporting the building.

BUILDING SITE. A contiguous area of land that is under the ownership or control of one entity.

BUILDING THERMAL ENVELOPE. The *basement walls*, *exterior walls*, floors, ceiling, roofs and any other *building* element assemblies that enclose *conditioned space* or provide a boundary between *conditioned space* and exempt or unconditioned space.

CIRCULATING HOT WATER SYSTEM. A specifically designed water distribution system where one or more pumps are operated in the service hot water piping to circulate heated water from the water-heating equipment to fixtures and back to the water-heating equipment.

CLIMATE ZONE. A geographical region based on climatic criteria as specified in this code.

CODE OFFICIAL. The officer or other designated authority charged with the administration and enforcement of this code, or a duly authorized representative.

COMMERCIAL BUILDING. For this code, all buildings that are not included in the definition of “*Residential building*.”

CONDITIONED FLOOR AREA. The horizontal projection of the floors associated with the *conditioned space*.

CONDITIONED SPACE. An area, room or space that is enclosed within the *building thermal envelope* and that is directly or indirectly heated or cooled. Spaces are indirectly heated or cooled where they communicate through openings

CHAPTER 3 [RE]

GENERAL REQUIREMENTS

User note:

About this chapter: Chapter 3 covers general regulations for energy conservation features of buildings. The climate zone for a building is established by geographic location tables and figures in this chapter.

SECTION R301 CLIMATE ZONES

R301.1 General. *Climate zones* from Figure R301.1 or Table R301.1 shall be used for determining the applicable requirements from Chapter 4. Locations not indicated in Table R301.1 shall be assigned a *climate zone* in accordance with Section R301.3.

R301.2 Warm humid counties. In Table R301.1, warm humid counties are identified by an asterisk.

R301.3 International climate zones. The *climate zone* for any location outside the United States shall be determined by applying Table R301.3(1) and then Table R301.3(2).

R301.4 Tropical climate zone. The tropical *climate zone* shall be defined as:

1. Hawaii, Puerto Rico, Guam, American Samoa, U.S. Virgin Islands, Commonwealth of Northern Mariana Islands; and
2. Islands in the area between the Tropic of Cancer and the Tropic of Capricorn.

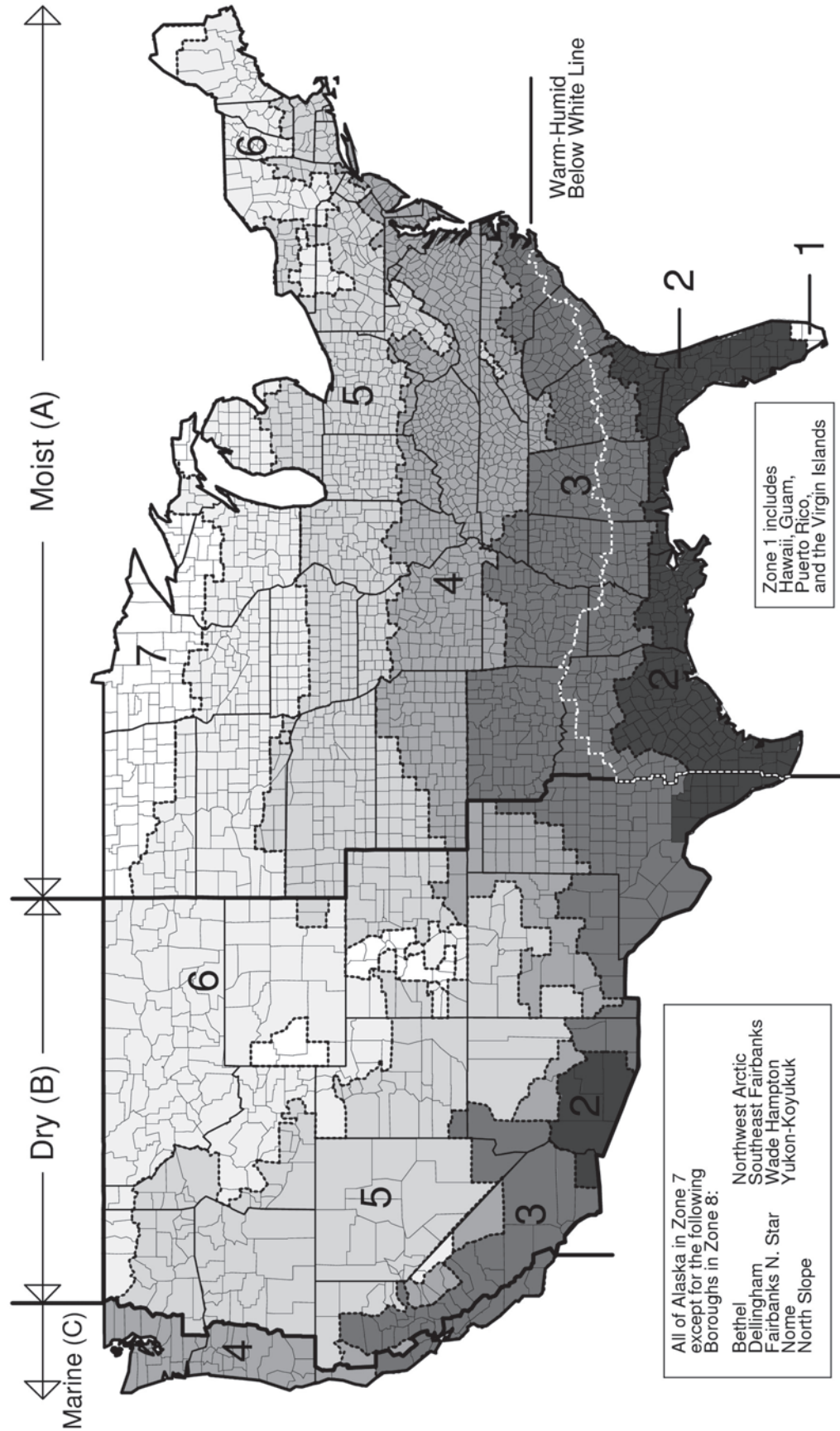

FIGURE R301.1 CLIMATE ZONES

TABLE R301.1
CLIMATE ZONES, MOISTURE REGIMES, AND WARM-HUMID
DESIGNATIONS BY STATE, COUNTY AND TERRITORY

Key: A – Moist, B – Dry, C – Marine. Absence of moisture designation indicates moisture regime is irrelevant.
Asterisk (*) indicates a warm-humid location.

US STATES

ALABAMA	3A Lee	7 Kodiak Island	3A Calhoun	3A Monroe
3A Autauga*	3A Limestone	7 Lake and Peninsula	4A Carroll	3A Montgomery
2A Baldwin*	3A Lowndes*	7 Matanuska-Susitna	3A Chicot	3A Nevada
3A Barbour*	3A Macon*	8 Nome	3A Clark	4A Newton
3A Bibb	3A Madison	8 North Slope	3A Clay	3A Ouachita
3A Blount	3A Marengo*	8 Northwest Arctic	3A Cleburne	3A Perry
3A Bullock*	3A Marion	7 Prince of Wales- Outer Ketchikan	3A Cleveland	3A Phillips
3A Butler*	3A Marshall	7 Sitka	3A Columbia*	3A Pike
3A Calhoun	2A Mobile*	7 Skagway-Hoonah- Angoon	3A Conway	3A Poinsett
3A Chambers	3A Monroe*	8 Southeast Fairbanks	3A Craighead	3A Polk
3A Cherokee	3A Montgomery*	7 Valdez-Cordova	3A Crawford	3A Pope
3A Chilton	3A Morgan	8 Wade Hampton	3A Crittenden	3A Prairie
3A Choctaw*	3A Perry*	7 Wrangell-Petersburg	3A Cross	3A Pulaski
3A Clarke*	3A Pickens	7 Yakutat	3A Dallas	3A Randolph
3A Clay	3A Pike*	8 Yukon-Koyukuk	3A Desha	3A Saline
3A Cleburne	3A Randolph	ARIZONA	3A Drew	3A Scott
3A Coffee*	3A Russell*	5B Apache	3A Faulkner	4A Searcy
3A Colbert	3A Shelby	3B Cochise	3A Franklin	3A Sebastian
3A Conecuh*	3A St. Clair	5B Coconino	4A Fulton	3A Sevier*
3A Coosa	3A Sumter	4B Gila	3A Garland	3A Sharp
3A Covington*	3A Talladega	3B Graham	3A Grant	3A St. Francis
3A Crenshaw*	3A Tallapoosa	3B Greenlee	3A Greene	4A Stone
3A Cullman	3A Tuscaloosa	2B La Paz	3A Hempstead*	3A Union*
3A Dale*	3A Walker	2B Maricopa	3A Hot Spring	3A Van Buren
3A Dallas*	3A Washington*	3B Mohave	3A Howard	4A Washington
3A DeKalb	3A Wilcox*	5B Navajo	3A Independence	3A White
3A Elmore*	3A Winston	2B Pima	4A IZard	3A Woodruff
3A Escambia*	ALASKA	4B Yavapai	3A Jackson	3A Yell
3A Etowah	7 Aleutians East	2B Yuma	3A Jefferson	CALIFORNIA
3A Fayette	7 Aleutians West	3B Santa Cruz	3A Johnson	3C Alameda
3A Franklin	7 Anchorage	4B Yavapai	3A Lafayette*	6B Alpine
3A Geneva*	8 Bethel	2B Yuma	3A Lawrence	4B Amador
3A Greene	7 Bristol Bay	ARKANSAS	3A Lee	3B Butte
3A Hale	7 Denali	3A Arkansas	3A Lincoln	4B Calaveras
3A Henry*	8 Dillingham	3A Ashley	3A Little River*	3B Colusa
3A Houston*	8 Fairbanks North Star	4A Baxter	3A Logan	3B Contra Costa
3A Jackson	7 Haines	4A Benton	3A Lonoke	4C Del Norte
3A Jefferson	7 Juneau	4A Boone	4A Madison	4B El Dorado
3A Lamar	7 Kenai Peninsula	3A Bradley	3A Miller*	3B Fresno
3A Lauderdale	7 Ketchikan Gateway		3A Mississippi	3B Glenn
3A Lawrence				

(continued)

GENERAL REQUIREMENTS

**TABLE R301.1—continued
CLIMATE ZONES, MOISTURE REGIMES, AND WARM-HUMID
DESIGNATIONS BY STATE, COUNTY AND TERRITORY**

4C Humboldt	3B Yuba	5B Montrose	2A Escambia*	2A Taylor*
2B Imperial	COLORADO	5B Morgan	2A Flagler*	2A Union*
4B Inyo	5B Adams	4B Otero	2A Franklin*	2A Volusia*
3B Kern	6B Alamosa	6B Ouray	2A Gadsden*	2A Wakulla*
3B Kings	5B Arapahoe	7 Park	2A Gilchrist*	2A Walton*
4B Lake	6B Archuleta	5B Phillips	2A Glades*	2A Washington*
5B Lassen	4B Baca	7 Pitkin	2A Gulf*	GEORGIA
3B Los Angeles	5B Bent	5B Prowers	2A Hamilton*	2A Appling*
3B Madera	5B Boulder	5B Pueblo	2A Hardee*	2A Atkinson*
3C Marin	5B Broomfield	6B Rio Blanco	2A Hendry*	2A Bacon*
4B Mariposa	6B Chaffee	7 Rio Grande	2A Hernando*	2A Baker*
3C Mendocino	5B Cheyenne	7 Routt	2A Highlands*	3A Baldwin
3B Merced	7 Clear Creek	6B Saguache	2A Hillsborough*	4A Banks
5B Modoc	6B Conejos	7 San Juan	2A Holmes*	3A Barrow
6B Mono	6B Costilla	6B San Miguel	2A Indian River*	3A Bartow
3C Monterey	5B Crowley	5B Sedgwick	2A Jackson*	3A Ben Hill*
3C Napa	6B Custer	7 Summit	2A Jefferson*	2A Berrien*
5B Nevada	5B Delta	5B Teller	2A Lafayette*	3A Bibb
3B Orange	5B Denver	5B Washington	2A Lake*	3A Bleckley*
3B Placer	6B Dolores	5B Weld	2A Lee*	2A Brantley*
5B Plumas	5B Douglas	5B Yuma	2A Leon*	2A Brooks*
3B Riverside	6B Eagle	CONNECTICUT	2A Levy*	2A Bryan*
3B Sacramento	5B Elbert	5A (all)	2A Liberty*	3A Bulloch*
3C San Benito	5B El Paso	DELAWARE	2A Madison*	3A Burke
3B San Bernardino	5B Fremont	4A (all)	2A Manatee*	3A Butts
3B San Diego	5B Garfield	DISTRICT OF	2A Marion*	3A Calhoun*
3C San Francisco	5B Gilpin	COLUMBIA	2A Martin*	2A Camden*
3B San Joaquin	7 Grand	4A (all)	1A Miami-Dade*	3A Candler*
3C San Luis Obispo	7 Gunnison	FLORIDA	2A Nassau*	3A Carroll
3C San Mateo	7 Hinsdale	2A Alachua*	2A Okaloosa*	4A Catoosa
3C Santa Barbara	5B Huerfano	2A Baker*	2A Okeechobee*	2A Charlton*
3C Santa Clara	7 Jackson	2A Bay*	2A Orange*	2A Chatham*
3C Santa Cruz	5B Jefferson	2A Bradford*	2A Osceola*	3A Chattahoochee*
3B Shasta	5B Kiowa	2A Brevard*	2A Palm Beach*	4A Chattooga
5B Sierra	5B Kit Carson	2A Broward*	2A Pasco*	3A Cherokee
5B Siskiyou	7 Lake	2A Calhoun*	2A Pinellas*	3A Clarke
3B Solano	5B La Plata	2A Charlotte*	2A Polk*	3A Clay*
3C Sonoma	5B Larimer	2A Citrus*	2A Putnam*	3A Clayton
3B Stanislaus	4B Las Animas	2A Clay*	2A Santa Rosa*	2A Clinch*
3B Sutter	5B Lincoln	2A Collier*	2A Sarasota*	3A Cobb
3B Tehama	5B Logan	2A Columbia*	2A Seminole*	3A Coffee*
4B Trinity	5B Mesa	2A DeSoto*	2A St. Johns*	2A Colquitt*
3B Tulare	7 Mineral	2A Dixie*	2A St. Lucie*	3A Columbia
4B Tuolumne	6B Moffat	2A Duval*	2A Sumter*	2A Cook*
3C Ventura	5B Montezuma		2A Suwannee*	3A Coweta
3B Yolo				

(continued)

TABLE R301.1—continued
CLIMATE ZONES, MOISTURE REGIMES, AND WARM-HUMID
DESIGNATIONS BY STATE, COUNTY AND TERRITORY

3A Crawford	2A Lanier*	3A Taylor*	5B Cassia	4A Crawford
3A Crisp*	3A Laurens*	3A Telfair*	6B Clark	5A Cumberland
4A Dade	3A Lee*	3A Terrell*	5B Clearwater	5A DeKalb
4A Dawson	2A Liberty*	2A Thomas*	6B Custer	5A De Witt
2A Decatur*	3A Lincoln	3A Tift*	5B Elmore	5A Douglas
3A DeKalb	2A Long*	2A Toombs*	6B Franklin	5A DuPage
3A Dodge*	2A Lowndes*	4A Towns	6B Fremont	5A Edgar
3A Dooly*	4A Lumpkin	3A Treutlen*	5B Gem	4A Edwards
3A Dougherty*	3A Macon*	3A Troup	5B Gooding	4A Effingham
3A Douglas	3A Madison	3A Turner*	5B Idaho	4A Fayette
3A Early*	3A Marion*	3A Twiggs*	6B Jefferson	5A Ford
2A Echols*	3A McDuffie	4A Union	5B Jerome	4A Franklin
2A Effingham*	2A McIntosh*	3A Upson	5B Kootenai	5A Fulton
3A Elbert	3A Meriwether	4A Walker	5B Latah	4A Gallatin
3A Emanuel*	2A Miller*	3A Walton	6B Lemhi	5A Greene
2A Evans*	2A Mitchell*	2A Ware*	5B Lewis	5A Grundy
4A Fannin	3A Monroe	3A Warren	5B Lincoln	4A Hamilton
3A Fayette	3A Montgomery*	3A Washington	6B Madison	5A Hancock
4A Floyd	3A Morgan	2A Wayne*	5B Minidoka	4A Hardin
3A Forsyth	4A Murray	3A Webster*	5B Nez Perce	5A Henderson
4A Franklin	3A Muscogee	3A Wheeler*	6B Oneida	5A Henry
3A Fulton	3A Newton	4A White	5B Owyhee	5A Iroquois
4A Gilmer	3A Oconee	4A Whitfield	5B Payette	4A Jackson
3A Glascock	3A Oglethorpe	3A Wilcox*	5B Power	4A Jasper
2A Glynn*	3A Paulding	3A Wilkes	5B Shoshone	4A Jefferson
4A Gordon	3A Peach*	3A Wilkinson	6B Teton	5A Jersey
2A Grady*	4A Pickens	3A Worth*	5B Twin Falls	5A Jo Daviess
3A Greene	2A Pierce*		6B Valley	4A Johnson
3A Gwinnett	3A Pike	HAWAII	5B Washington	5A Kane
4A Habersham	3A Polk	1A (all)*		5A Kankakee
4A Hall	3A Pulaski*	IDAHO	ILLINOIS	5A Kendall
3A Hancock	3A Putnam	5B Ada	5A Adams	5A Knox
3A Haralson	3A Quitman*	6B Adams	4A Alexander	5A Lake
3A Harris	4A Rabun	6B Bannock	4A Bond	5A La Salle
3A Hart	3A Randolph*	6B Bear Lake	5A Boone	4A Lawrence
3A Heard	3A Richmond	5B Benewah	5A Brown	5A Lee
3A Henry	3A Rockdale	6B Bingham	5A Bureau	5A Livingston
3A Houston*	3A Schley*	6B Blaine	5A Calhoun	5A Logan
3A Irwin*	3A Screven*	6B Boise	5A Carroll	5A Macon
3A Jackson	2A Seminole*	6B Bonner	5A Cass	4A Macoupin
3A Jasper	3A Spalding	6B Bonneville	5A Champaign	4A Madison
2A Jeff Davis*	4A Stephens	6B Boundary	4A Christian	4A Marion
3A Jefferson	3A Stewart*	6B Butte	5A Clark	5A Marshall
3A Jenkins*	3A Sumter*	6B Camas	4A Clay	5A Mason
3A Johnson*	3A Talbot	5B Canyon	4A Clinton	4A Massac
3A Jones	3A Taliaferro	6B Caribou	5A Coles	5A McDonough
3A Lamar	2A Tattnell*		5A Cook	5A McHenry

(continued)

GENERAL REQUIREMENTS

TABLE R301.1—continued
CLIMATE ZONES, MOISTURE REGIMES, AND WARM-HUMID
DESIGNATIONS BY STATE, COUNTY AND TERRITORY

5A McLean	5A Boone	5A Miami	5A Appanoose	5A Jasper
5A Menard	4A Brown	4A Monroe	5A Audubon	5A Jefferson
5A Mercer	5A Carroll	5A Montgomery	5A Benton	5A Johnson
4A Monroe	5A Cass	5A Morgan	6A Black Hawk	5A Jones
4A Montgomery	4A Clark	5A Newton	5A Boone	5A Keokuk
5A Morgan	5A Clay	5A Noble	6A Bremer	6A Kossuth
5A Moultrie	5A Clinton	4A Ohio	6A Buchanan	5A Lee
5A Ogle	4A Crawford	4A Orange	6A Buena Vista	5A Linn
5A Peoria	4A Daviess	5A Owen	6A Butler	5A Louisa
4A Perry	4A Dearborn	5A Parke	6A Calhoun	5A Lucas
5A Piatt	5A Decatur	4A Perry	5A Carroll	6A Lyon
5A Pike	5A De Kalb	4A Pike	5A Cass	5A Madison
4A Pope	5A Delaware	5A Porter	5A Cedar	5A Mahaska
4A Pulaski	4A Dubois	4A Posey	6A Cerro Gordo	5A Marion
5A Putnam	5A Elkhart	5A Pulaski	6A Cherokee	5A Marshall
4A Randolph	5A Fayette	5A Putnam	6A Chickasaw	5A Mills
4A Richland	4A Floyd	5A Randolph	5A Clarke	6A Mitchell
5A Rock Island	5A Fountain	4A Ripley	6A Clay	5A Monona
4A Saline	5A Franklin	5A Rush	6A Clayton	5A Monroe
5A Sangamon	5A Fulton	4A Scott	5A Clinton	5A Montgomery
5A Schuyler	4A Gibson	5A Shelby	5A Crawford	5A Muscatine
5A Scott	5A Grant	4A Spencer	5A Dallas	6A O'Brien
4A Shelby	4A Greene	5A Starke	5A Davis	6A Osceola
5A Stark	5A Hamilton	5A Steuben	5A Decatur	5A Page
4A St. Clair	5A Hancock	5A St. Joseph	6A Delaware	6A Palo Alto
5A Stephenson	4A Harrison	4A Sullivan	5A Des Moines	6A Plymouth
5A Tazewell	5A Hendricks	4A Switzerland	6A Dickinson	6A Pocahontas
4A Union	5A Henry	5A Tippecanoe	5A Dubuque	5A Polk
5A Vermilion	5A Howard	5A Tipton	6A Emmet	5A Pottawattamie
4A Wabash	5A Huntington	5A Union	6A Fayette	5A Poweshiek
5A Warren	4A Jackson	4A Vanderburgh	6A Floyd	5A Ringgold
4A Washington	5A Jasper	5A Vermillion	6A Franklin	6A Sac
4A Wayne	5A Jay	5A Vigo	5A Fremont	5A Scott
4A White	4A Jefferson	5A Wabash	5A Greene	5A Shelby
5A Whiteside	4A Jennings	5A Warren	6A Grundy	6A Sioux
5A Will	5A Johnson	4A Warrick	5A Guthrie	5A Story
4A Williamson	4A Knox	4A Washington	6A Hamilton	5A Tama
5A Winnebago	5A Kosciusko	5A Wayne	6A Hancock	5A Taylor
5A Woodford	5A LaGrange	5A Wells	6A Hardin	5A Union
INDIANA	5A Lake	5A White	5A Harrison	5A Van Buren
5A Adams	5A LaPorte	5A Whitley	5A Henry	5A Wapello
5A Allen	4A Lawrence	IOWA	6A Howard	5A Warren
5A Bartholomew	5A Madison	5A Adair	6A Humboldt	5A Washington
5A Benton	5A Marion	5A Adams	6A Ida	5A Wayne
5A Blackford	5A Marshall	6A Allamakee	5A Iowa	6A Webster
	4A Martin		5A Jackson	6A Winnebago

(continued)

TABLE R301.1—continued
CLIMATE ZONES, MOISTURE REGIMES, AND WARM-HUMID
DESIGNATIONS BY STATE, COUNTY AND TERRITORY

6A Winneshiek	4A Haskell	4A Sedgwick	2A Iberville*	6A Cumberland
5A Woodbury	4A Hodgeman	4A Seward	3A Jackson*	6A Franklin
6A Worth	4A Jackson	4A Shawnee	2A Jefferson*	6A Hancock
6A Wright	4A Jefferson	5A Sheridan	2A Jefferson Davis*	6A Kennebec
KANSAS	5A Jewell	5A Sherman	2A Lafayette*	6A Knox
4A Allen	4A Johnson	5A Smith	2A Lafourche*	6A Lincoln
4A Anderson	4A Kearny	4A Stafford	3A La Salle*	6A Oxford
4A Atchison	4A Kingman	4A Stanton	3A Lincoln*	6A Penobscot
4A Barber	4A Kiowa	4A Stevens	2A Livingston*	6A Piscataquis
4A Barton	4A Labette	4A Sumner	3A Madison*	6A Sagadahoc
4A Bourbon	5A Lane	5A Thomas	3A Morehouse	6A Somerset
4A Brown	4A Leavenworth	5A Trego	3A Natchitoches*	6A Waldo
4A Butler	4A Lincoln	4A Wabaunsee	2A Orleans*	6A Washington
4A Chase	4A Linn	5A Wallace	3A Ouachita*	6A York
4A Chautauqua	5A Logan	4A Washington	2A Plaquemines*	MARYLAND
4A Cherokee	4A Lyon	5A Wichita	2A Pointe Coupee*	4A Allegany
5A Cheyenne	4A Marion	4A Wilson	2A Rapides*	4A Anne Arundel
4A Clark	4A Marshall	4A Woodson	3A Red River*	4A Baltimore
4A Clay	4A McPherson	4A Wyandotte	3A Richland*	4A Baltimore (city)
5A Cloud	4A Meade	KENTUCKY	3A Sabine*	4A Calvert
4A Coffey	4A Miami	4A (all)	2A St. Bernard*	4A Caroline
4A Comanche	5A Mitchell	LOUISIANA	2A St. Charles*	4A Carroll
4A Cowley	4A Montgomery	2A Acadia*	2A St. Helena*	4A Cecil
4A Crawford	4A Morris	2A Allen*	2A St. James*	4A Charles
5A Decatur	4A Morton	2A Ascension*	2A St. John the Baptist*	4A Dorchester
4A Dickinson	4A Nemaha	2A Assumption*	2A St. Landry*	4A Frederick
4A Doniphan	4A Neosho	2A Avoyelles*	2A St. Martin*	5A Garrett
4A Douglas	5A Ness	2A Beauregard*	2A St. Mary*	4A Harford
4A Edwards	5A Norton	3A Bienville*	2A St. Tammany*	4A Howard
4A Elk	4A Osage	3A Bossier*	2A Tangipahoa*	4A Kent
5A Ellis	5A Osborne	3A Caddo*	3A Tensas*	4A Montgomery
4A Ellsworth	4A Ottawa	2A Calcasieu*	2A Terrebonne*	4A Prince George's
4A Finney	4A Pawnee	3A Caldwell*	3A Union*	4A Queen Anne's
4A Ford	5A Phillips	2A Cameron*	2A Vermilion*	4A Somerset
4A Franklin	4A Pottawatomie	3A Catahoula*	3A Vernon*	4A St. Mary's
4A Geary	4A Pratt	3A Claiborne*	2A Washington*	4A Talbot
5A Gove	5A Rawlins	3A Concordia*	3A Webster*	4A Washington
5A Graham	4A Reno	3A De Soto*	2A West Baton Rouge*	4A Wicomico
4A Grant	5A Republic	2A East Baton Rouge*	3A West Carroll	4A Worcester
4A Gray	4A Rice	3A East Carroll	2A West Feliciana*	MASSACHUSETTS
5A Greeley	4A Riley	2A East Feliciana*	3A Winn*	5A (all)
4A Greenwood	5A Rooks	2A Evangeline*	MAINE	MICHIGAN
5A Hamilton	4A Rush	3A Franklin*	6A Androscoggin	6A Alcona
4A Harper	4A Russell	3A Grant*	7 Aroostook	6A Alger
4A Harvey	4A Saline	2A Iberia*		
	5A Scott			

(continued)

GENERAL REQUIREMENTS

**TABLE R301.1—continued
CLIMATE ZONES, MOISTURE REGIMES, AND WARM-HUMID
DESIGNATIONS BY STATE, COUNTY AND TERRITORY**

5A Allegan	7 Mackinac	6A Carver	7 Otter Tail	3A Clarke
6A Alpena	5A Macomb	7 Cass	7 Pennington	3A Clay
6A Antrim	6A Manistee	6A Chippewa	7 Pine	3A Coahoma
6A Arenac	6A Marquette	6A Chisago	6A Pipestone	3A Copiah*
7 Baraga	6A Mason	7 Clay	7 Polk	3A Covington*
5A Barry	6A Mecosta	7 Clearwater	6A Pope	3A DeSoto
5A Bay	6A Menominee	7 Cook	6A Ramsey	3A Forrest*
6A Benzie	5A Midland	6A Cottonwood	7 Red Lake	3A Franklin*
5A Berrien	6A Missaukee	7 Crow Wing	6A Redwood	3A George*
5A Branch	5A Monroe	6A Dakota	6A Renville	3A Greene*
5A Calhoun	5A Montcalm	6A Dodge	6A Rice	3A Grenada
5A Cass	6A Montmorency	6A Douglas	6A Rock	2A Hancock*
6A Charlevoix	5A Muskegon	6A Faribault	7 Roseau	2A Harrison*
6A Cheboygan	6A Newaygo	6A Fillmore	6A Scott	3A Hinds*
7 Chippewa	5A Oakland	6A Freeborn	6A Sherburne	3A Holmes
6A Clare	6A Oceana	6A Goodhue	6A Sibley	3A Humphreys
5A Clinton	6A Ogemaw	7 Grant	6A Stearns	3A Issaquena
6A Crawford	7 Ontonagon	6A Hennepin	6A Steele	3A Itawamba
6A Delta	6A Osceola	6A Houston	6A Stevens	2A Jackson*
6A Dickinson	6A Oscoda	7 Hubbard	7 St. Louis	3A Jasper
5A Eaton	6A Otsego	6A Isanti	6A Swift	3A Jefferson*
6A Emmet	5A Ottawa	7 Itasca	6A Todd	3A Jefferson Davis*
5A Genesee	6A Presque Isle	6A Jackson	6A Traverse	3A Jones*
6A Gladwin	6A Roscommon	7 Kanabec	6A Wabasha	3A Kemper
7 Gogebic	5A Saginaw	6A Kandiyohi	7 Wadena	3A Lafayette
6A Grand Traverse	6A Sanilac	7 Kittson	6A Waseca	3A Lamar*
5A Gratiot	7 Schoolcraft	7 Koochiching	6A Washington	3A Lauderdale
5A Hillsdale	5A Shiawassee	6A Lac qui Parle	6A Watonwan	3A Lawrence*
7 Houghton	5A St. Clair	7 Lake	7 Wilkin	3A Leake
6A Huron	5A St. Joseph	7 Lake of the Woods	6A Winona	3A Lee
5A Ingham	5A Tuscola	6A Le Sueur	6A Wright	3A Leflore
5A Ionia	5A Van Buren	6A Lincoln	6A Yellow	3A Lincoln*
6A Iosco	5A Washtenaw	6A Lyon	Medicine	3A Lowndes
7 Iron	5A Wayne	7 Mahanomen	MISSISSIPPI	3A Madison
6A Isabella	6A Wexford	7 Marshall	3A Adams*	3A Marion*
5A Jackson	MINNESOTA	6A Martin	3A Alcorn	3A Marshall
5A Kalamazoo	7 Aitkin	6A McLeod	3A Amite*	3A Monroe
6A Kalkaska	6A Anoka	6A Meeker	3A Attala	3A Montgomery
5A Kent	7 Becker	7 Mille Lacs	3A Benton	3A Neshoba
7 Keweenaw	7 Beltrami	6A Morrison	3A Bolivar	3A Newton
6A Lake	6A Benton	6A Mower	3A Calhoun	3A Noxubee
5A Lapeer	6A Big Stone	6A Murray	3A Carroll	3A Oktibbeha
6A Leelanau	6A Blue Earth	6A Nicollet	3A Chickasaw	3A Panola
5A Lenawee	6A Brown	6A Nobles	3A Choctaw	2A Pearl River*
5A Livingston	7 Carlton	7 Norman	3A Claiborne*	3A Perry*
7 Luce		6A Olmsted		3A Pike*

(continued)

TABLE R301.1—continued
CLIMATE ZONES, MOISTURE REGIMES, AND WARM-HUMID
DESIGNATIONS BY STATE, COUNTY AND TERRITORY

3A Pontotoc	5A Chariton	4A Mississippi	4A Webster	4A Cumberland
3A Prentiss	4A Christian	4A Moniteau	5A Worth	4A Essex
3A Quitman	5A Clark	4A Monroe	4A Wright	4A Gloucester
3A Rankin*	4A Clay	4A Montgomery	MONTANA	4A Hudson
3A Scott	5A Clinton	4A Morgan	6B (all)	5A Hunterdon
3A Sharkey	4A Cole	4A New Madrid	NEBRASKA	5A Mercer
3A Simpson*	4A Cooper	4A Newton	5A (all)	4A Middlesex
3A Smith*	4A Crawford	5A Nodaway	NEVADA	4A Monmouth
2A Stone*	4A Dade	4A Oregon	5B Carson City (city)	5A Morris
3A Sunflower	4A Dallas	4A Osage	5B Churchill	4A Ocean
3A Tallahatchie	5A Daviess	4A Ozark	3B Clark	5A Passaic
3A Tate	5A DeKalb	4A Pemiscot	5B Douglas	4A Salem
3A Tippah	4A Dent	4A Perry	5B Elko	5A Somerset
3A Tishomingo	4A Douglas	4A Pettis	5B Esmeralda	5A Sussex
3A Tunica	4A Dunklin	4A Phelps	5B Eureka	4A Union
3A Union	4A Franklin	5A Pike	5B Humboldt	5A Warren
3A Walthall*	4A Gasconade	4A Platte	5B Lander	NEW MEXICO
3A Warren*	5A Gentry	4A Polk	5B Lincoln	4B Bernalillo
3A Washington	4A Greene	4A Pulaski	5B Lyon	5B Catron
3A Wayne*	5A Grundy	5A Putnam	5B Mineral	3B Chaves
3A Webster	5A Harrison	5A Ralls	5B Nye	4B Cibola
3A Wilkinson*	4A Henry	4A Randolph	5B Pershing	5B Colfax
3A Winston	4A Hickory	4A Ray	5B Storey	4B Curry
3A Yalobusha	5A Holt	4A Reynolds	5B Washoe	4B DeBaca
3A Yazoo	4A Howard	4A Ripley	5B White Pine	3B Dona Ana
MISSOURI	4A Howell	4A Saline	NEW	3B Eddy
5A Adair	4A Iron	5A Schuyler	HAMPSHIRE	4B Grant
5A Andrew	4A Jackson	5A Scotland	6A Belknap	4B Guadalupe
5A Atchison	4A Jasper	4A Scott	6A Carroll	5B Harding
4A Audrain	4A Jefferson	4A Shannon	5A Cheshire	3B Hidalgo
4A Barry	4A Johnson	5A Shelby	6A Coos	3B Lea
4A Barton	5A Knox	4A St. Charles	6A Grafton	4B Lincoln
4A Bates	4A Laclede	4A St. Clair	5A Hillsborough	5B Los Alamos
4A Benton	4A Lafayette	4A St. Francois	6A Merrimack	3B Luna
4A Bollinger	4A Lawrence	4A St. Louis	5A Rockingham	5B McKinley
4A Boone	5A Lewis	4A St. Louis (city)	5A Strafford	5B Mora
5A Buchanan	4A Lincoln	4A Ste. Genevieve	6A Sullivan	3B Otero
4A Butler	5A Linn	4A Stoddard	4A Atlantic	4B Quay
5A Caldwell	5A Livingston	4A Stone	5A Bergen	5B Rio Arriba
4A Callaway	5A Macon	5A Sullivan	4A Burlington	4B Roosevelt
4A Camden	4A Madison	4A Taney	4A Camden	5B Sandoval
4A Cape Girardeau	4A Maries	4A Texas	4A Cape May	5B San Juan
4A Carroll	5A Marion	4A Vernon		5B San Miguel
4A Carter	4A McDonald	4A Warren		5B Santa Fe
4A Cass	5A Mercer	4A Washington		4B Sierra
4A Cedar	4A Miller	4A Wayne		4B Socorro

(continued)

GENERAL REQUIREMENTS

TABLE R301.1—continued
CLIMATE ZONES, MOISTURE REGIMES, AND WARM-HUMID
DESIGNATIONS BY STATE, COUNTY AND TERRITORY

5B Taos	4A Queens	4A Clay	4A Orange	7 Divide
5B Torrance	5A Rensselaer	4A Cleveland	3A Pamlico	6A Dunn
4B Union	4A Richmond	3A Columbus*	3A Pasquotank	7 Eddy
4B Valencia	5A Rockland	3A Craven	3A Pender*	6A Emmons
NEW YORK	5A Saratoga	3A Cumberland	3A Perquimans	7 Foster
5A Albany	5A Schenectady	3A Currituck	4A Person	6A Golden Valley
6A Allegany	6A Schoharie	3A Dare	3A Pitt	7 Grand Forks
4A Bronx	6A Schuyler	3A Davidson	4A Polk	6A Grant
6A Broome	5A Seneca	4A Davie	3A Randolph	7 Griggs
6A Cattaraugus	6A Steuben	3A Duplin	3A Richmond	6A Hettinger
5A Cayuga	6A St. Lawrence	4A Durham	3A Robeson	7 Kidder
5A Chautauqua	4A Suffolk	3A Edgecombe	4A Rockingham	6A LaMoure
5A Chemung	6A Sullivan	4A Forsyth	3A Rowan	6A Logan
6A Chenango	5A Tioga	4A Franklin	4A Rutherford	7 McHenry
6A Clinton	6A Tompkins	3A Gaston	3A Sampson	6A McIntosh
5A Columbia	6A Ulster	4A Gates	3A Scotland	6A McKenzie
5A Cortland	6A Warren	4A Graham	3A Stanly	7 McLean
6A Delaware	5A Washington	4A Granville	4A Stokes	6A Mercer
5A Dutchess	5A Wayne	3A Greene	4A Surry	6A Morton
5A Erie	4A Westchester	4A Guilford	4A Swain	7 Mountrail
6A Essex	6A Wyoming	4A Halifax	4A Transylvania	7 Nelson
6A Franklin	5A Yates	4A Harnett	3A Tyrrell	6A Oliver
6A Fulton	NORTH	4A Haywood	3A Union	7 Pembina
5A Genesee	CAROLINA	4A Henderson	4A Vance	7 Pierce
5A Greene	4A Alamance	4A Hertford	4A Wake	7 Ramsey
6A Hamilton	4A Alexander	3A Hoke	4A Warren	6A Ransom
6A Herkimer	5A Alleghany	3A Hyde	3A Washington	7 Renville
6A Jefferson	3A Anson	4A Iredell	5A Watauga	6A Richland
4A Kings	5A Ashe	4A Jackson	3A Wayne	7 Rolette
6A Lewis	5A Avery	3A Johnston	4A Wilkes	6A Sargent
5A Livingston	3A Beaufort	4A Lee	3A Wilson	7 Sheridan
6A Madison	4A Bertie	3A Lenoir	4A Yadkin	6A Sioux
5A Monroe	3A Bladen	4A Lincoln	5A Yancey	6A Slope
6A Montgomery	3A Brunswick*	4A Macon	NORTH DAKOTA	6A Stark
4A Nassau	4A Buncombe	4A Madison	6A Adams	7 Steele
4A New York	4A Burke	3A Martin	7 Barnes	7 Stutsman
5A Niagara	3A Cabarrus	4A McDowell	7 Benson	7 Towner
6A Oneida	4A Caldwell	3A Mecklenburg	6A Billings	7 Traill
5A Onondaga	3A Camden	5A Mitchell	7 Bottineau	7 Walsh
5A Ontario	3A Carteret*	3A Montgomery	6A Bowman	7 Ward
5A Orange	4A Caswell	3A Moore	7 Burke	7 Wells
5A Orleans	4A Catawba	4A Nash	6A Burleigh	7 Williams
5A Oswego	4A Chatham	3A New Hanover*	7 Cass	OHIO
6A Otsego	4A Cherokee	4A Northampton	7 Cavalier	4A Adams
5A Putnam	3A Chowan	3A Onslow*	6A Dickey	5A Allen

(continued)

TABLE R301.1—continued
CLIMATE ZONES, MOISTURE REGIMES, AND WARM-HUMID
DESIGNATIONS BY STATE, COUNTY AND TERRITORY

5A Ashland	5A Mahoning	3A Bryan	3A Okfuskee	4C Linn
5A Ashtabula	5A Marion	3A Caddo	3A Oklahoma	5B Malheur
5A Athens	5A Medina	3A Canadian	3A Okmulgee	4C Marion
5A Auglaize	5A Meigs	3A Carter	3A Osage	5B Morrow
5A Belmont	5A Mercer	3A Cherokee	3A Ottawa	4C Multnomah
4A Brown	5A Miami	3A Choctaw	3A Pawnee	4C Polk
5A Butler	5A Monroe	4B Cimarron	3A Payne	5B Sherman
5A Carroll	5A Montgomery	3A Cleveland	3A Pittsburg	4C Tillamook
5A Champaign	5A Morgan	3A Coal	3A Pontotoc	5B Umatilla
5A Clark	5A Morrow	3A Comanche	3A Pottawatomie	5B Union
4A Clermont	5A Muskingum	3A Cotton	3A Pushmataha	5B Wallowa
5A Clinton	5A Noble	3A Craig	3A Roger Mills	5B Wasco
5A Columbiana	5A Ottawa	3A Creek	3A Rogers	4C Washington
5A Coshocton	5A Paulding	3A Custer	3A Seminole	5B Wheeler
5A Crawford	5A Perry	3A Delaware	3A Sequoyah	4C Yamhill
5A Cuyahoga	5A Pickaway	3A Dewey	3A Stephens	
5A Darke	4A Pike	3A Ellis	4B Texas	PENNSYLVANIA
5A Defiance	5A Portage	3A Garfield	3A Tillman	5A Adams
5A Delaware	5A Preble	3A Garvin	3A Tulsa	5A Allegheny
5A Erie	5A Putnam	3A Grady	3A Wagoner	5A Armstrong
5A Fairfield	5A Richland	3A Grant	3A Washington	5A Beaver
5A Fayette	5A Ross	3A Greer	3A Washita	5A Bedford
5A Franklin	5A Sandusky	3A Harmon	3A Woods	5A Berks
5A Fulton	4A Scioto	3A Harper	3A Woodward	5A Blair
4A Gallia	5A Seneca	3A Haskell		5A Bradford
5A Geauga	5A Shelby	3A Hughes	OREGON	4A Bucks
5A Greene	5A Stark	3A Jackson	5B Baker	5A Butler
5A Guernsey	5A Summit	3A Jefferson	4C Benton	5A Cambria
4A Hamilton	5A Trumbull	3A Johnston	4C Clackamas	6A Cameron
5A Hancock	5A Tuscarawas	3A Kay	4C Clatsop	5A Carbon
5A Hardin	5A Union	3A Kingfisher	4C Columbia	5A Centre
5A Harrison	5A Van Wert	3A Kiowa	4C Coos	4A Chester
5A Henry	5A Vinton	3A Latimer	5B Crook	5A Clarion
5A Highland	5A Warren	3A Le Flore	4C Curry	6A Clearfield
5A Hocking	4A Washington	3A Lincoln	5B Deschutes	5A Clinton
5A Holmes	5A Wayne	3A Logan	4C Douglas	5A Columbia
5A Huron	5A Williams	3A Love	5B Gilliam	5A Crawford
5A Jackson	5A Wood	3A Major	5B Grant	5A Cumberland
5A Jefferson	5A Wyandot	3A Marshall	5B Harney	5A Dauphin
5A Knox		3A Mayes	5B Hood River	4A Delaware
5A Lake	OKLAHOMA	3A McClain	4C Jackson	6A Elk
4A Lawrence	3A Adair	3A McCurtain	5B Jefferson	5A Erie
5A Licking	3A Alfalfa	3A McIntosh	4C Josephine	5A Fayette
5A Logan	3A Atoka	3A Murray	5B Klamath	5A Forest
5A Lorain	4B Beaver	3A Muskogee	5B Lake	5A Franklin
5A Lucas	3A Beckham	3A Noble	4C Lane	5A Fulton
5A Madison	3A Blaine	3A Nowata	4C Lincoln	5A Greene

(continued)

GENERAL REQUIREMENTS

**TABLE R301.1—continued
CLIMATE ZONES, MOISTURE REGIMES, AND WARM-HUMID
DESIGNATIONS BY STATE, COUNTY AND TERRITORY**

5A Huntingdon	3A Bamberg*	5A Bennett	6A Minnehaha	4A Gibson
5A Indiana	3A Barnwell*	5A Bon Homme	6A Moody	4A Giles
5A Jefferson	3A Beaufort*	6A Brookings	6A Pennington	4A Grainger
5A Juniata	3A Berkeley*	6A Brown	6A Perkins	4A Greene
5A Lackawanna	3A Calhoun	6A Brule	6A Potter	4A Grundy
5A Lancaster	3A Charleston*	6A Buffalo	6A Roberts	4A Hamblen
5A Lawrence	3A Cherokee	6A Butte	6A Sanborn	4A Hamilton
5A Lebanon	3A Chester	6A Campbell	6A Shannon	4A Hancock
5A Lehigh	3A Chesterfield	5A Charles Mix	6A Spink	3A Hardeman
5A Luzerne	3A Clarendon	6A Clark	6A Stanley	3A Hardin
5A Lycoming	3A Colleton*	5A Clay	6A Sully	4A Hawkins
6A McKean	3A Darlington	6A Codrington	5A Todd	3A Haywood
5A Mercer	3A Dillon	6A Corson	5A Tripp	3A Henderson
5A Mifflin	3A Dorchester*	6A Custer	6A Turner	4A Henry
5A Monroe	3A Edgefield	6A Davison	5A Union	4A Hickman
4A Montgomery	3A Fairfield	6A Day	6A Walworth	4A Houston
5A Montour	3A Florence	6A Deuel	5A Yankton	4A Humphreys
5A Northampton	3A Georgetown*	6A Dewey	6A Ziebach	4A Jackson
5A Northumberland	3A Greenville	5A Douglas	TENNESSEE	4A Jefferson
5A Perry	3A Greenwood	6A Edmunds	4A Anderson	4A Johnson
4A Philadelphia	3A Hampton*	6A Fall River	4A Bedford	4A Knox
5A Pike	3A Horry*	6A Faulk	4A Benton	3A Lake
6A Potter	3A Jasper*	6A Grant	4A Bledsoe	3A Lauderdale
5A Schuylkill	3A Kershaw	5A Gregory	4A Blount	4A Lawrence
5A Snyder	3A Lancaster	6A Haakon	4A Bradley	4A Lewis
5A Somerset	3A Laurens	6A Hamlin	4A Campbell	4A Lincoln
5A Sullivan	3A Lee	6A Hand	4A Cannon	4A Loudon
6A Susquehanna	3A Lexington	6A Hanson	4A Carroll	4A Macon
6A Tioga	3A Marion	6A Harding	4A Carter	3A Madison
5A Union	3A Marlboro	6A Hughes	4A Cheatham	4A Marion
5A Venango	3A McCormick	5A Hutchinson	3A Chester	4A Marshall
5A Warren	3A Newberry	6A Hyde	4A Claiborne	4A Maury
5A Washington	3A Oconee	5A Jackson	4A Clay	4A McMinn
6A Wayne	3A Orangeburg	6A Jerauld	4A Coker	3A McNairy
5A Westmoreland	3A Pickens	6A Jones	4A Coffee	4A Meigs
5A Wyoming	3A Richland	6A Kingsbury	3A Crockett	4A Monroe
4A York	3A Saluda	6A Lake	4A Cumberland	4A Montgomery
RHODE ISLAND	3A Spartanburg	6A Lawrence	4A Davidson	4A Moore
5A (all)	3A Sumter	6A Lincoln	4A Decatur	4A Morgan
SOUTH	3A Union	6A Lyman	4A DeKalb	4A Obion
CAROLINA	3A Williamsburg	6A Marshall	4A Dickson	4A Overton
3A Abbeville	3A York	6A McCook	3A Dyer	4A Perry
3A Aiken	SOUTH DAKOTA	6A McPherson	3A Fayette	4A Pickett
3A Allendale*	6A Aurora	6A Meade	4A Fentress	4A Polk
3A Anderson	6A Beadle	5A Mellette	4A Franklin	4A Putnam
		6A Miner		4A Rhea

(continued)

TABLE R301.1—continued
CLIMATE ZONES, MOISTURE REGIMES, AND WARM-HUMID
DESIGNATIONS BY STATE, COUNTY AND TERRITORY

4A Roane	3B Brewster	3B Ector	3B Howard	3B McCulloch
4A Robertson	4B Briscoe	2B Edwards	3B Hudspeth	2A McLennan*
4A Rutherford	2A Brooks*	3A Ellis*	3A Hunt*	2A McMullen*
4A Scott	3A Brown*	3B El Paso	4B Hutchinson	2B Medina
4A Sequatchie	2A Burlison*	3A Erath*	3B Irion	3B Menard
4A Sevier	3A Burnet*	2A Falls*	3A Jack	3B Midland
3A Shelby	2A Caldwell*	3A Fannin	2A Jackson*	2A Milam*
4A Smith	2A Calhoun*	2A Fayette*	2A Jasper*	3A Mills*
4A Stewart	3B Callahan	3B Fisher	3B Jeff Davis	3B Mitchell
4A Sullivan	2A Cameron*	4B Floyd	2A Jefferson*	3A Montague
4A Sumner	3A Camp*	3B Foard	2A Jim Hogg*	2A Montgomery*
3A Tipton	4B Carson	2A Fort Bend*	2A Jim Wells*	4B Moore
4A Trousdale	3A Cass*	3A Franklin*	3A Johnson*	3A Morris*
4A Unicoi	4B Castro	2A Freestone*	3B Jones	3B Motley
4A Union	2A Chambers*	2B Frio	2A Karnes*	3A Nacogdoches*
4A Van Buren	2A Cherokee*	3B Gaines	3A Kaufman*	3A Navarro*
4A Warren	3B Childress	2A Galveston*	3A Kendall*	2A Newton*
4A Washington	3A Clay	3B Garza	2A Kenedy*	3B Nolan
4A Wayne	4B Cochran	3A Gillespie*	3B Kent	2A Nueces*
4A Weakley	3B Coke	3B Glasscock	3B Kerr	4B Ochiltree
4A White	3B Coleman	2A Goliad*	3B Kimble	4B Oldham
4A Williamson	3A Collin*	2A Gonzales*	3B King	2A Orange*
4A Wilson	3B Collingsworth	4B Gray	2B Kinney	3A Palo Pinto*
TEXAS	2A Colorado*	3A Grayson	2A Kleberg*	3A Panola*
2A Anderson*	2A Comal*	3A Gregg*	3B Knox	3A Parker*
3B Andrews	3A Comanche*	2A Grimes*	3A Lamar*	4B Parmer
2A Angelina*	3B Concho	2A Guadalupe*	4B Lamb	3B Pecos
2A Aransas*	3A Cooke	4B Hale	3A Lampasas*	2A Polk*
3A Archer	2A Coryell*	3B Hall	2B La Salle	4B Potter
4B Armstrong	3B Cottle	3A Hamilton*	2A Lavaca*	3B Presidio
2A Atascosa*	3B Crane	4B Hansford	2A Lee*	3A Rains*
2A Austin*	3B Crockett	3B Hardeman	2A Leon*	4B Randall
4B Bailey	3B Crosby	2A Hardin*	2A Liberty*	3B Reagan
2B Bandera	3B Culberson	2A Harris*	2A Limestone*	2B Real
2A Bastrop*	4B Dallam	3A Harrison*	4B Lipscomb	3A Red River*
3B Baylor	3A Dallas*	4B Hartley	2A Live Oak*	3B Reeves
2A Bee*	3B Dawson	3B Haskell	3A Llano*	2A Refugio*
2A Bell*	4B Deaf Smith	2A Hays*	3B Loving	4B Roberts
2A Bexar*	3A Delta	3B Hemphill	3B Lubbock	2A Robertson*
3A Blanco*	3A Denton*	3A Henderson*	3B Lynn	3A Rockwall*
3B Borden	2A DeWitt*	2A Hidalgo*	2A Madison*	3B Runnels
2A Bosque*	3B Dickens	2A Hill*	3A Marion*	3A Rusk*
3A Bowie*	2B Dimmit	4B Hockley	3B Martin	3A Sabine*
2A Brazoria*	4B Donley	3A Hood*	3B Mason	3A San Augustine*
2A Brazos*	2A Duval*	3A Hopkins*	2A Matagorda*	2A San Jacinto*
	3A Eastland	2A Houston*	2B Maverick	2A San Patricio*

(continued)

GENERAL REQUIREMENTS

**TABLE R301.1—continued
CLIMATE ZONES, MOISTURE REGIMES, AND WARM-HUMID
DESIGNATIONS BY STATE, COUNTY AND TERRITORY**

3A San Saba*	3A Young	4C Clark	4A Gilmer	WISCONSIN
3B Schleicher	2B Zapata	5B Columbia	5A Grant	
3B Scurry	2B Zavala	4C Cowlitz	5A Greenbrier	
3B Shackelford		5B Douglas	5A Hampshire	
3A Shelby*	UTAH	6B Ferry	5A Hancock	
4B Sherman	5B Beaver	5B Franklin	5A Hardy	
3A Smith*	6B Box Elder	5B Garfield	5A Harrison	
3A Somervell*	6B Cache	5B Grant	4A Jackson	
2A Starr*	6B Carbon	4C Grays Harbor	4A Jefferson	
3A Stephens	6B Daggett	4C Island	4A Kanawha	
3B Sterling	5B Davis	4C Jefferson	5A Lewis	
3B Stonewall	6B Duchesne	4C King	4A Lincoln	
3B Sutton	5B Emery	4C Kitsap	4A Logan	
4B Swisher	5B Garfield	5B Kittitas	5A Marion	
3A Tarrant*	5B Grand	5B Klickitat	5A Marshall	
3B Taylor	5B Iron	4C Lewis	4A Mason	
3B Terrell	5B Juab	5B Lincoln	4A McDowell	
3B Terry	5B Kane	4C Mason	4A Mercer	
3B Throckmorton	5B Millard	6B Okanogan	5A Mineral	
3A Titus*	6B Morgan	4C Pacific	4A Mingo	
3B Tom Green	5B Piute	6B Pend Oreille	5A Monongalia	
2A Travis*	6B Rich	4C Pierce	4A Monroe	
2A Trinity*	5B Salt Lake	4C San Juan	4A Morgan	
2A Tyler*	5B San Juan	4C Skagit	5A Nicholas	
3A Upshur*	5B Sanpete	5B Skamania	5A Ohio	
3B Upton	5B Sevier	4C Snohomish	5A Pendleton	
2B Uvalde	6B Summit	5B Spokane	4A Pleasants	
2B Val Verde	5B Tooele	6B Stevens	5A Pocahontas	
3A Van Zandt*	6B Uintah	4C Thurston	5A Preston	
2A Victoria*	5B Utah	4C Wahkiakum	4A Putnam	
2A Walker*	6B Wasatch	5B Walla Walla	5A Raleigh	
2A Waller*	3B Washington	4C Whatcom	5A Randolph	
3B Ward	5B Wayne	5B Whitman	4A Ritchie	
2A Washington*	5B Weber	5B Yakima	4A Roane	
2B Webb	VERMONT	WEST VIRGINIA	5A Summers	
2A Wharton*	6A (all)	5A Barbour	5A Taylor	
3B Wheeler	VIRGINIA	4A Berkeley	5A Tucker	
3A Wichita	4A (all)	4A Boone	4A Tyler	
3B Wilbarger	WASHINGTON	4A Braxton	5A Upshur	
2A Willacy*	5B Adams	5A Brooke	4A Wayne	
2A Williamson*	5B Asotin	4A Cabell	5A Webster	
2A Wilson*	5B Benton	4A Calhoun	5A Wetzel	
3B Winkler	5B Benton	4A Clay	4A Wirt	
3A Wise	5B Chelan	5A Doddridge	4A Wood	
3A Wood*	4C Clallam	5A Fayette	4A Wyoming	
4B Yoakum				

(continued)

TABLE R301.1—continued
CLIMATE ZONES, MOISTURE REGIMES, AND WARM-HUMID
DESIGNATIONS BY STATE, COUNTY AND TERRITORY

6A Ozaukee	7 Taylor	6B Big Horn	6B Sheridan	NORTHERN MARIANA ISLANDS
6A Pepin	6A Trempealeau	6B Campbell	7 Sublette	
6A Pierce	6A Vernon	6B Carbon	6B Sweetwater	1A (all)*
6A Polk	7 Vilas	6B Converse	7 Teton	PUERTO RICO
6A Portage	6A Walworth	6B Crook	6B Uinta	
7 Price	7 Washburn	6B Fremont	6B Washakie	1A (all)*
6A Racine	6A Washington	5B Goshen	6B Weston	VIRGIN ISLANDS
6A Richland	6A Waukesha	6B Hot Springs		
6A Rock	6A Waupaca	6B Johnson	US TERRITORIES	AMERICAN SAMOA
6A Rusk	6A Waushara	6B Laramie		
6A Sauk	6A Winnebago	7 Lincoln	AMERICAN SAMOA	1A (all)*
7 Sawyer	6A Wood	6B Natrona		GUAM
6A Shawano	WYOMING	6B Niobrara		
6A Sheboygan	6B Albany	6B Park		1A (all)*
6A St. Croix		5B Platte		

TABLE R301.3(1)
INTERNATIONAL CLIMATE ZONE DEFINITIONS

MAJOR CLIMATE-TYPE DEFINITIONS
<p>Marine (C) Definition—Locations meeting all four criteria:</p> <ol style="list-style-type: none"> 1. Mean temperature of coldest month between -3°C (27°F) and 18°C (65°F). 2. Warmest month mean < 22°C (72°F). 3. Not fewer than four months with mean temperatures over 10°C (50°F). 4. Dry season in summer. The month with the heaviest precipitation in the cold season has not less than three times as much precipitation as the month with the least precipitation in the rest of the year. The cold season is October through March in the Northern Hemisphere and April through September in the Southern Hemisphere.
<p>Dry (B) Definition—Locations meeting the following criteria:</p> <p>Not marine and $P_m < 0.44 \times (TF - 19.5)$ $[P_{cm} < 2.0 \times (TC + 7)$ in SI units]</p> <p>where:</p> <p>P_m = Annual precipitation in inches (cm)</p> <p>T = Annual mean temperature in °F (°C)</p>
<p>Moist (A) Definition—Locations that are not marine and not dry.</p>
<p>Warm-humid Definition—Moist (A) locations where either of the following wet-bulb temperature conditions shall occur during the warmest six consecutive months of the year:</p> <ol style="list-style-type: none"> 1. 67°F (19.4°C) or higher for 3,000 or more hours. 2. 73°F (22.8°C) or higher for 1,500 or more hours.

For SI: °C = [(°F) - 32]/1.8, 1 inch = 2.54 cm.

TABLE R301.3(2)
INTERNATIONAL CLIMATE ZONE DEFINITIONS

ZONE NUMBER	THERMAL CRITERIA	
	IP Units	SI Units
1	9000 < CDD50°F	5000 < CDD10°C
2	6300 < CDD50°F ≤ 9000	3500 < CDD10°C ≤ 5000
3A and 3B	4500 < CDD50°F ≤ 6300 AND HDD65°F ≤ 5400	2500 < CDD10°C ≤ 3500 AND HDD18°C ≤ 3000
4A and 4B	CDD50°F ≤ 4500 AND HDD65°F ≤ 5400	CDD10°C ≤ 2500 AND HDD18°C ≤ 3000
3C	HDD65°F ≤ 3600	HDD18°C ≤ 2000
4C	3600 < HDD65°F ≤ 5400	2000 < HDD18°C ≤ 3000
5	5400 < HDD65°F ≤ 7200	3000 < HDD18°C ≤ 4000
6	7200 < HDD65°F ≤ 9000	4000 < HDD18°C ≤ 5000
7	9000 < HDD65°F ≤ 12600	5000 < HDD18°C ≤ 7000
8	12600 < HDD65°F	7000 < HDD18°C

For SI: °C = [(°F) - 32]/1.8.

**SECTION R302
DESIGN CONDITIONS**

R302.1 Interior design conditions. The interior design temperatures used for heating and cooling load calculations shall be a maximum of 72°F (22°C) for heating and minimum of 75°F (24°C) for cooling.

**SECTION R303
MATERIALS, SYSTEMS AND EQUIPMENT**

R303.1 Identification. Materials, systems and equipment shall be identified in a manner that will allow a determination of compliance with the applicable provisions of this code.

R303.1.1 Building thermal envelope insulation. An *R*-value identification mark shall be applied by the manufacturer to each piece of *building thermal envelope* insulation that is 12 inches (305 mm) or greater in width. Alternatively, the insulation installers shall provide a certification that indicates the type, manufacturer and *R*-value of insulation installed in each element of the *building thermal envelope*. For blown-in or sprayed fiberglass and cellulose insulation, the initial installed thickness, settled thickness, settled *R*-value, installed density, coverage area and number of bags installed shall be indicated on the certification. For sprayed polyurethane foam (SPF) insulation, the installed thickness of the areas covered and the *R*-value of the installed thickness shall be indicated on the certification. For insulated siding, the *R*-value shall be on a label on the product’s package and shall be indicated on the certification. The insulation installer shall sign, date and post the certification in a conspicuous location on the job site.

Exception: For roof insulation installed above the deck, the *R*-value shall be labeled as required by the material standards specified in Table 1508.2 of the *International Building Code* or Table R906.2 of the *International Residential Code*, as applicable.

R303.1.1.1 Blown-in or sprayed roof and ceiling insulation. The thickness of blown-in or sprayed fiberglass and cellulose roof and ceiling insulation shall be written in inches (mm) on markers that are installed at

not less than one for every 300 square feet (28 m²) throughout the attic space. The markers shall be affixed to the trusses or joists and marked with the minimum initial installed thickness with numbers not less than 1 inch (25 mm) in height. Each marker shall face the attic access opening. The thickness and installed *R*-value of sprayed polyurethane foam insulation shall be indicated on the certification provided by the insulation installer.

R303.1.2 Insulation mark installation. Insulating materials shall be installed such that the manufacturer’s *R*-value mark is readily observable at inspection.

R303.1.3 Fenestration product rating. *U*-factors of fenestration products such as windows, doors and *skylights* shall be determined in accordance with NFRC 100.

Exception: Where required, garage door *U*-factors shall be determined in accordance with either NFRC 100 or ANSI/DASMA 105.

U-factors shall be determined by an accredited, independent laboratory, and labeled and certified by the manufacturer.

Products lacking such a labeled *U*-factor shall be assigned a default *U*-factor from Table R303.1.3(1) or R303.1.3(2). The *solar heat gain coefficient* (SHGC) and *visible transmittance* (VT) of glazed fenestration products such as windows, glazed doors and *skylights* shall be determined in accordance with NFRC 200 by an accredited, independent laboratory, and labeled and certified by the manufacturer. Products lacking such a labeled SHGC or VT shall be assigned a default SHGC or VT from Table R303.1.3(3).

R303.1.4 Insulation product rating. The thermal resistance, *R*-value, of insulation shall be determined in accordance with Part 460 of US-FTC CFR Title 16 in units of h • ft² • °F/Btu at a mean temperature of 75°F (24°C).

R303.1.4.1 Insulated siding. The thermal resistance, *R*-value, of insulated siding shall be determined in accordance with ASTM C1363. Installation for testing shall be in accordance with the manufacturer’s instructions.

TABLE R303.1.3(1)
DEFAULT GLAZED WINDOW,
GLASS DOOR AND SKYLIGHT U-FACTORS

FRAME TYPE	WINDOW AND GLASS DOOR		SKYLIGHT	
	Single pane	Double pane	Single	Double
Metal	1.20	0.80	2.00	1.30
Metal with Thermal Break	1.10	0.65	1.90	1.10
Nonmetal or Metal Clad	0.95	0.55	1.75	1.05
Glazed Block	0.60			

TABLE R303.1.3(2)
DEFAULT OPAQUE DOOR U-FACTORS

DOOR TYPE	OPAQUE U-FACTOR
Uninsulated Metal	1.20
Insulated Metal	0.60
Wood	0.50
Insulated, nonmetal edge, not exceeding 45% glazing, any glazing double pane	0.35

TABLE R303.1.3(3)
DEFAULT GLAZED FENESTRATION SHGC AND VT

	SINGLE GLAZED		DOUBLE GLAZED		GLAZED BLOCK
	Clear	Tinted	Clear	Tinted	
SHGC	0.8	0.7	0.7	0.6	0.6
VT	0.6	0.3	0.6	0.3	0.6

R303.2 Installation. Materials, systems and equipment shall be installed in accordance with the manufacturer's instructions and the *International Building Code* or the *International Residential Code*, as applicable.

R303.2.1 Protection of exposed foundation insulation.

Insulation applied to the exterior of *basement walls*, crawl space walls and the perimeter of slab-on-grade floors shall have a rigid, opaque and weather-resistant protective covering to prevent the degradation of the insulation's thermal performance. The protective covering shall cover the exposed exterior insulation and extend not less than 6 inches (153 mm) below grade.

R303.3 Maintenance information. Maintenance instructions shall be furnished for equipment and systems that require preventive maintenance. Required regular maintenance actions shall be clearly stated and incorporated on a readily *accessible* label. The label shall include the title or publication number for the operation and maintenance manual for that particular model and type of product.

CHAPTER 4 [RE]

RESIDENTIAL ENERGY EFFICIENCY

User note:

About this chapter: Chapter 4 provides requirements for the thermal envelope of a building, including minimum insulation values for walls, ceiling and floors; maximum fenestration U-factors; minimum fenestration solar heat gain coefficients; and methods for determining building assembly and a total building U-factor. A performance alternative and an energy rating alternative are also provided to allow for energy code compliance other than by the prescriptive method.

SECTION R401 GENERAL

R401.1 Scope. This chapter applies to *residential buildings*.

R401.2 Compliance. Projects shall comply with one of the following:

1. Sections R401 through R404.
2. Section R405 and the provisions of Sections R401 through R404 indicated as “Mandatory.”
3. The energy rating index (ERI) approach in Section R406.

R401.2.1 Tropical zone. *Residential buildings* in the tropical zone at elevations less than 2,400 feet (731.5 m) above sea level shall be deemed to be in compliance with this chapter provided that the following conditions are met:

1. Not more than one-half of the occupied space is air conditioned.
2. The occupied space is not heated.
3. Solar, wind or other renewable energy source supplies not less than 80 percent of the energy for service water heating.
4. Glazing in *conditioned spaces* has a *solar heat gain coefficient* of less than or equal to 0.40, or has an overhang with a projection factor equal to or greater than 0.30.
5. Permanently installed lighting is in accordance with Section R404.
6. The exterior roof surface complies with one of the options in Table C402.3 or the roof or ceiling has insulation with an *R*-value of R-15 or greater. Where attics are present, attics above the insulation are vented and attics below the insulation are unvented.
7. Roof surfaces have a slope of not less than one-fourth unit vertical in 12 units horizontal (21-percent slope). The finished roof does not have water accumulation areas.
8. Operable fenestration provides a ventilation area of not less than 14 percent of the floor area in each room. Alternatively, equivalent ventilation is provided by a ventilation fan.
9. Bedrooms with *exterior walls* facing two different directions have operable fenestration on *exterior walls* facing two directions.
10. Interior doors to bedrooms are capable of being secured in the open position.

11. A ceiling fan or ceiling fan rough-in is provided for bedrooms and the largest space that is not used as a bedroom.

R401.3 Certificate (Mandatory). A permanent certificate shall be completed by the builder or other *approved* party and posted on a wall in the space where the furnace is located, a utility room or an *approved* location inside the *building*. Where located on an electrical panel, the certificate shall not cover or obstruct the visibility of the circuit directory label, service disconnect label or other required labels. The certificate shall indicate the predominant *R*-values of insulation installed in or on ceilings, roofs, walls, foundation components such as slabs, *basement walls*, crawl space walls and floors and ducts outside *conditioned spaces*; *U*-factors of fenestration and the *solar heat gain coefficient* (SHGC) of fenestration, and the results from any required duct system and *building* envelope air leakage testing performed on the *building*. Where there is more than one value for each component, the certificate shall indicate the value covering the largest area. The certificate shall indicate the types and efficiencies of heating, cooling and service water heating equipment. Where a gas-fired unvented room heater, electric furnace or baseboard electric heater is installed in the residence, the certificate shall indicate “gas-fired unvented room heater,” “electric furnace” or “baseboard electric heater,” as appropriate. An efficiency shall not be indicated for gas-fired unvented room heaters, electric furnaces and electric baseboard heaters.

SECTION R402 BUILDING THERMAL ENVELOPE

R402.1 General (Prescriptive). The *building thermal envelope* shall comply with the requirements of Sections R402.1.1 through R402.1.5.

Exceptions:

1. The following low-energy *buildings*, or portions thereof, separated from the remainder of the building by *building thermal envelope* assemblies complying with this section shall be exempt from the *building thermal envelope* provisions of Section R402.
 - 1.1. Those with a peak design rate of energy usage less than 3.4 Btu/h • ft² (10.7 W/m²) or 1.0 watt/ft² of floor area for space-conditioning purposes.
 - 1.2. Those that do not contain *conditioned space*.
2. Log homes designed in accordance with ICC 400.

R402.1.1 Vapor retarder. Wall assemblies in the *building thermal envelope* shall comply with the vapor retarder requirements of Section R702.7 of the *International Residential Code* or Section 1405.3 of the *International Building Code*, as applicable.

R402.1.2 Insulation and fenestration criteria. The *building thermal envelope* shall meet the requirements of Table R402.1.2, based on the *climate zone* specified in Chapter 3.

R402.1.3 R-value computation. Insulation material used in layers, such as framing *cavity insulation* or continuous

insulation, shall be summed to compute the corresponding component *R*-value. The manufacturer’s settled *R*-value shall be used for blown-in insulation. Computed *R*-values shall not include an *R*-value for other building materials or air films. Where insulated siding is used for the purpose of complying with the continuous insulation requirements of Table R402.1.2, the manufacturer’s labeled *R*-value for the insulated siding shall be reduced by R-0.6.

R402.1.4 U-factor alternative. An assembly with a *U*-factor equal to or less than that specified in Table R402.1.4 shall be an alternative to the *R*-value in Table R402.1.2.

**TABLE R402.1.2
INSULATION AND FENESTRATION REQUIREMENTS BY COMPONENT^a**

CLIMATE ZONE	FENESTRATION U-FACTOR ^b	SKYLIGHT ^b U-FACTOR	GLAZED FENESTRATION SHGC ^{b, e}	CEILING R-VALUE	WOOD FRAME WALL R-VALUE	MASS WALL R-VALUE ^f	FLOOR R-VALUE	BASEMENT ^c WALL R-VALUE	SLAB ^d R-VALUE & DEPTH	CRAWL SPACE ^e WALL R-VALUE
1	NR	0.75	0.25	30	13	3/4	13	0	0	0
2	0.40	0.65	0.25	38	13	4/6	13	0	0	0
3	0.32	0.55	0.25	38	20 or 13+5 ^h	8/13	19	5/13 ^f	0	5/13
4 except Marine	0.32	0.55	0.40	49	20 or 13+5 ^h	8/13	19	10/13	10, 2 ft	10/13
5 and Marine 4	0.30	0.55	NR	49	20 or 13+5 ^h	13/17	30 ^g	15/19	10, 2 ft	15/19
6	0.30	0.55	NR	49	20+5 ^h or 13+10 ^h	15/20	30 ^g	15/19	10, 4 ft	15/19
7 and 8	0.30	0.55	NR	49	20+5 ^h or 13+10 ^h	19/21	38 ^g	15/19	10, 4 ft	15/19

NR = Not Required.

For SI: 1 foot = 304.8 mm.

- R*-values are minimums. *U*-factors and SHGC are maximums. Where insulation is installed in a cavity that is less than the label or design thickness of the insulation, the installed *R*-value of the insulation shall be not less than the *R*-value specified in the table.
- The fenestration *U*-factor column excludes skylights. The SHGC column applies to all glazed fenestration.
Exception: In Climate Zones 1 through 3, skylights shall be permitted to be excluded from glazed fenestration SHGC requirements provided that the SHGC for such skylights does not exceed 0.30.
- “10/13” means R-10 continuous insulation on the interior or exterior of the home or R-13 cavity insulation on the interior of the basement wall.
“15/19” means R-15 continuous insulation on the interior or exterior of the home or R-19 cavity insulation at the interior of the basement wall. Alternatively, compliance with “15/19” shall be R-13 cavity insulation on the interior of the basement wall plus R-5 continuous insulation on the interior or exterior of the home.
- R-5 insulation shall be provided under the full slab area of a heated slab in addition to the required slab edge insulation *R*-value for slabs, as indicated in the table. The slab edge insulation for heated slabs shall not be required to extend below the slab.
- There are no SHGC requirements in the Marine Zone.
- Basement wall insulation is not required in warm-humid locations as defined by Figure R301.1 and Table R301.1.
- Alternatively, insulation sufficient to fill the framing cavity and providing not less than an *R*-value of R-19.
- The first value is cavity insulation, the second value is continuous insulation. Therefore, as an example, “13+5” means R-13 cavity insulation plus R-5 continuous insulation.
- Mass walls shall be in accordance with Section R402.2.5. The second *R*-value applies where more than half of the insulation is on the interior of the mass wall.

**TABLE R402.1.4
EQUIVALENT U-FACTORS^a**

CLIMATE ZONE	FENESTRATION U-FACTOR	SKYLIGHT U-FACTOR	CEILING U-FACTOR	FRAME WALL U-FACTOR	MASS WALL U-FACTOR ^b	FLOOR U-FACTOR	BASEMENT WALL U-FACTOR	CRAWL SPACE WALL U-FACTOR
1	0.50	0.75	0.035	0.084	0.197	0.064	0.360	0.477
2	0.40	0.65	0.030	0.084	0.165	0.064	0.360	0.477
3	0.32	0.55	0.030	0.060	0.098	0.047	0.091 ^c	0.136
4 except Marine	0.32	0.55	0.026	0.060	0.098	0.047	0.059	0.065
5 and Marine 4	0.30	0.55	0.026	0.060	0.082	0.033	0.050	0.055
6	0.30	0.55	0.026	0.045	0.060	0.033	0.050	0.055
7 and 8	0.30	0.55	0.026	0.045	0.057	0.028	0.050	0.055

- Nonfenestration *U*-factors shall be obtained from measurement, calculation or an approved source.
- Mass walls shall be in accordance with Section R402.2.5. Where more than half the insulation is on the interior, the mass wall *U*-factors shall not exceed 0.17 in Climate Zone 1, 0.14 in Climate Zone 2, 0.12 in Climate Zone 3, 0.087 in Climate Zone 4 except Marine, 0.065 in Climate Zone 5 and Marine 4, and 0.057 in Climate Zones 6 through 8.
- In warm-humid locations as defined by Figure R301.1 and Table R301.1, the basement wall *U*-factor shall not exceed 0.360.

R402.1.5 Total UA alternative. Where the total *building thermal envelope* UA, the sum of *U*-factor times assembly area, is less than or equal to the total UA resulting from multiplying the *U*-factors in Table R402.1.4 by the same assembly area as in the proposed *building*, the *building* shall be considered to be in compliance with Table R402.1.2. The UA calculation shall be performed using a method consistent with the ASHRAE *Handbook of Fundamentals* and shall include the thermal bridging effects of framing materials. In addition to UA compliance, the SHGC requirements shall be met.

R402.2 Specific insulation requirements (Prescriptive). In addition to the requirements of Section R402.1, insulation shall meet the specific requirements of Sections R402.2.1 through R402.2.13.

R402.2.1 Ceilings with attic spaces. Where Section R402.1.2 requires R-38 insulation in the ceiling, installing R-30 over 100 percent of the ceiling area requiring insulation shall satisfy the requirement for R-38 wherever the full height of uncompressed R-30 insulation extends over the wall top plate at the eaves. Where Section R402.1.2 requires R-49 insulation in the ceiling, installing R-38 over 100 percent of the ceiling area requiring insulation shall satisfy the requirement for R-49 insulation wherever the full height of uncompressed R-38 insulation extends over the wall top plate at the eaves. This reduction shall not apply to the *U*-factor alternative approach in Section R402.1.4 and the Total UA alternative in Section R402.1.5.

R402.2.2 Ceilings without attic spaces. Where Section R402.1.2 requires insulation *R*-values greater than R-30 in the ceiling and the design of the roof/ceiling assembly does not allow sufficient space for the required insulation, the minimum required insulation *R*-value for such roof/ceiling assemblies shall be R-30. Insulation shall extend over the top of the wall plate to the outer edge of such plate and shall not be compressed. This reduction of insulation from the requirements of Section R402.1.2 shall be limited to 500 square feet (46 m²) or 20 percent of the total insulated ceiling area, whichever is less. This reduction shall not apply to the *U*-factor alternative approach in Section R402.1.4 and the Total UA alternative in Section R402.1.5.

R402.2.3 Eave baffle. For air-permeable insulations in vented attics, a baffle shall be installed adjacent to soffit and eave vents. Baffles shall maintain an opening equal or greater than the size of the vent. The baffle shall extend over the top of the attic insulation. The baffle shall be permitted to be any solid material.

R402.2.4 Access hatches and doors. Access doors from *conditioned spaces* to *unconditioned spaces* such as attics and crawl spaces shall be weatherstripped and insulated to a level equivalent to the insulation on the surrounding surfaces. Access that prevents damaging or compressing the insulation shall be provided to all equipment. Where loose-fill insulation is installed, a wood-framed or equivalent baffle or retainer shall be installed to prevent the loose-fill insulation from spilling into the living space when the attic access is opened. The baffle or retainer shall

provide a permanent means of maintaining the installed *R*-value of the loose-fill insulation.

Exception: Vertical doors providing access from *conditioned spaces* to *unconditioned spaces* that comply with the fenestration requirements of Table R402.1.2 based on the applicable *climate zone* specified in Chapter 3.

R402.2.5 Mass walls. Mass walls where used as a component of the *building thermal envelope* shall be one of the following:

1. Above-ground walls of concrete block, concrete, insulated concrete form, masonry cavity, brick but not brick veneer, adobe, compressed earth block, rammed earth, solid timber or solid logs.
2. Any wall having a heat capacity greater than or equal to 6 Btu/ft² • °F (123 kJ/m² • K).

R402.2.6 Steel-frame ceilings, walls and floors. Steel-frame ceilings, walls, and floors shall comply with the

**TABLE R402.2.6
STEEL-FRAME CEILING, WALL
AND FLOOR INSULATION R-VALUES**

WOOD FRAME R-VALUE REQUIREMENT	COLD-FORMED STEEL-FRAME EQUIVALENT R-VALUE ^a
Steel Truss Ceilings^b	
R-30	R-38 or R-30 + 3 or R-26 + 5
R-38	R-49 or R-38 + 3
R-49	R-38 + 5
Steel Joist Ceilings^b	
R-30	R-38 in 2 × 4 or 2 × 6 or 2 × 8 R-49 in any framing
R-38	R-49 in 2 × 4 or 2 × 6 or 2 × 8 or 2 × 10
Steel-Framed Wall, 16 inches on center	
R-13	R-13 + 4.2 or R-21 + 2.8 or R-0 + 9.3 or R-15 + 3.8 or R-21 + 3.1
R-13 + 3	R-0 + 11.2 or R-13 + 6.1 or R-15 + 5.7 or R-19 + 5.0 or R-21 + 4.7
R-20	R-0 + 14.0 or R-13 + 8.9 or R-15 + 8.5 or R-19 + 7.8 or R-19 + 6.2 or R-21 + 7.5
R-20 + 5	R-13 + 12.7 or R-15 + 12.3 or R-19 + 11.6 or R-21 + 11.3 or R-25 + 10.9
R-21	R-0 + 14.6 or R-13 + 9.5 or R-15 + 9.1 or R-19 + 8.4 or R-21 + 8.1 or R-25 + 7.7
Steel Framed Wall, 24 inches on center	
R-13	R-0 + 9.3 or R-13 + 3.0 or R-15 + 2.4
R-13 + 3	R-0 + 11.2 or R-13 + 4.9 or R-15 + 4.3 or R-19 + 3.5 or R-21 + 3.1
R-20	R-0 + 14.0 or R-13 + 7.7 or R-15 + 7.1 or R-19 + 6.3 or R-21 + 5.9
R-20 + 5	R-13 + 11.5 or R-15 + 10.9 or R-19 + 10.1 or R-21 + 9.7 or R-25 + 9.1
R-21	R-0 + 14.6 or R-13 + 8.3 or R-15 + 7.7 or R-19 + 6.9 or R-21 + 6.5 or R-25 + 5.9
Steel Joist Floor	
R-13	R-19 in 2 × 6, or R-19 + 6 in 2 × 8 or 2 × 10
R-19	R-19 + 6 in 2 × 6, or R-19 + 12 in 2 × 8 or 2 × 10

a. The first value is cavity insulation *R*-value, the second value is continuous insulation *R*-value. Therefore, for example, "R-30+3" means R-30 cavity insulation plus R-3 continuous insulation.

b. Insulation exceeding the height of the framing shall cover the framing.

**TABLE R402.4.1.1
AIR BARRIER AND INSULATION INSTALLATION^a**

COMPONENT	AIR BARRIER CRITERIA	INSULATION INSTALLATION CRITERIA
General requirements	A continuous air barrier shall be installed in the building envelope. The exterior thermal envelope contains a continuous air barrier. Breaks or joints in the air barrier shall be sealed.	Air-permeable insulation shall not be used as a sealing material.
Ceiling/attic	The air barrier in any dropped ceiling or soffit shall be aligned with the insulation and any gaps in the air barrier shall be sealed. Access openings, drop down stairs or knee wall doors to unconditioned attic spaces shall be sealed.	The insulation in any dropped ceiling/soffit shall be aligned with the air barrier.
Walls	The junction of the foundation and sill plate shall be sealed. The junction of the top plate and the top of exterior walls shall be sealed. Knee walls shall be sealed.	Cavities within corners and headers of frame walls shall be insulated by completely filling the cavity with a material having a thermal resistance, <i>R</i> -value, of not less than R-3 per inch. Exterior thermal envelope insulation for framed walls shall be installed in substantial contact and continuous alignment with the air barrier.
Windows, skylights and doors	The space between framing and skylights, and the jambs of windows and doors, shall be sealed.	—
Rim joists	Rim joists shall include the air barrier.	Rim joists shall be insulated.
Floors, including cantilevered floors and floors above garages	The air barrier shall be installed at any exposed edge of insulation.	Floor framing cavity insulation shall be installed to maintain permanent contact with the underside of subfloor decking. Alternatively, floor framing cavity insulation shall be in contact with the top side of sheathing, or continuous insulation installed on the underside of floor framing; and shall extend from the bottom to the top of all perimeter floor framing members.
Crawl space walls	Exposed earth in unvented crawl spaces shall be covered with a Class I vapor retarder with overlapping joints taped.	Crawl space insulation, where provided instead of floor insulation, shall be permanently attached to the walls.
Shafts, penetrations	Duct shafts, utility penetrations, and flue shafts opening to exterior or unconditioned space shall be sealed.	—
Narrow cavities	—	Batts to be installed in narrow cavities shall be cut to fit or narrow cavities shall be filled with insulation that on installation readily conforms to the available cavity space.
Garage separation	Air sealing shall be provided between the garage and conditioned spaces.	—
Recessed lighting	Recessed light fixtures installed in the building thermal envelope shall be sealed to the finished surface.	Recessed light fixtures installed in the building thermal envelope shall be air tight and IC rated.
Plumbing and wiring	—	In exterior walls, batt insulation shall be cut neatly to fit around wiring and plumbing, or insulation, that on installation readily conforms to available space, shall extend behind piping and wiring.
Shower/tub on exterior wall	The air barrier installed at exterior walls adjacent to showers and tubs shall separate the wall from the shower or tub.	Exterior walls adjacent to showers and tubs shall be insulated.
Electrical/phone box on exterior walls	The air barrier shall be installed behind electrical and communication boxes. Alternatively, air-sealed boxes shall be installed.	—
HVAC register boots	HVAC supply and return register boots that penetrate building thermal envelope shall be sealed to the subfloor, wall covering or ceiling penetrated by the boot.	—
Concealed sprinklers	Where required to be sealed, concealed fire sprinklers shall only be sealed in a manner that is recommended by the manufacturer. Caulking or other adhesive sealants shall not be used to fill voids between fire sprinkler cover plates and walls or ceilings.	—

a. Inspection of log walls shall be in accordance with the provisions of ICC 400.

SECTION R403 SYSTEMS

R403.1 Controls (Mandatory). Not less than one thermostat shall be provided for each separate heating and cooling system.

R403.1.1 Programmable thermostat. The thermostat controlling the primary heating or cooling system of the dwelling unit shall be capable of controlling the heating and cooling system on a daily schedule to maintain different temperature setpoints at different times of the day. This thermostat shall include the capability to set back or temporarily operate the system to maintain *zone* temperatures of not less than 55°F (13°C) to not greater than 85°F (29°C). The thermostat shall be programmed initially by the manufacturer with a heating temperature setpoint of not greater than 70°F (21°C) and a cooling temperature setpoint of not less than 78°F (26°C).

R403.1.2 Heat pump supplementary heat (Mandatory). Heat pumps having supplementary electric-resistance heat shall have controls that, except during defrost, prevent supplemental heat operation when the heat pump compressor can meet the heating load.

R403.2 Hot water boiler outdoor temperature setback. Hot water boilers that supply heat to the *building* through one- or two-pipe heating systems shall have an outdoor setback control that decreases the boiler water temperature based on the outdoor temperature.

R403.3 Ducts. Ducts and air handlers shall be installed in accordance with Sections R403.3.1 through R403.3.7.

R403.3.1 Insulation (Prescriptive). Supply and return ducts in attics shall be insulated to an *R*-value of not less than *R*-8 for ducts 3 inches (76 mm) in diameter and larger and not less than *R*-6 for ducts smaller than 3 inches (76 mm) in diameter. Supply and return ducts in other portions of the *building* shall be insulated to not less than *R*-6 for ducts 3 inches (76 mm) in diameter and not less than *R*-4.2 for ducts smaller than 3 inches (76 mm) in diameter.

Exception: Ducts or portions thereof located completely inside the *building thermal envelope*.

R403.3.2 Sealing (Mandatory). Ducts, air handlers and filter boxes shall be sealed. Joints and seams shall comply with either the *International Mechanical Code* or *International Residential Code*, as applicable.

R403.3.2.1 Sealed air handler. Air handlers shall have a manufacturer's designation for an air leakage of not greater than 2 percent of the design airflow rate when tested in accordance with ASHRAE 193.

R403.3.3 Duct testing (Mandatory). Ducts shall be pressure tested to determine air leakage by one of the following methods:

1. Rough-in test: Total leakage shall be measured with a pressure differential of 0.1 inch w.g. (25 Pa) across the system, including the manufacturer's air handler enclosure if installed at the time of the test. Registers shall be taped or otherwise sealed during the test.

2. Postconstruction test: Total leakage shall be measured with a pressure differential of 0.1 inch w.g. (25 Pa) across the entire system, including the manufacturer's air handler enclosure. Registers shall be taped or otherwise sealed during the test.

Exceptions:

1. A duct air-leakage test shall not be required where the ducts and air handlers are located entirely within the *building thermal envelope*.
2. A duct air-leakage test shall not be required for ducts serving heat or energy recovery ventilators that are not integrated with ducts serving heating or cooling systems.

A written report of the results of the test shall be signed by the party conducting the test and provided to the *code official*.

R403.3.4 Duct leakage (Prescriptive). The total leakage of the ducts, where measured in accordance with Section R403.3.3, shall be as follows:

1. Rough-in test: The total leakage shall be less than or equal to 4 cubic feet per minute (113.3 L/min) per 100 square feet (9.29 m²) of conditioned floor area where the air handler is installed at the time of the test. Where the air handler is not installed at the time of the test, the total leakage shall be less than or equal to 3 cubic feet per minute (85 L/min) per 100 square feet (9.29 m²) of conditioned floor area.
2. Postconstruction test: Total leakage shall be less than or equal to 4 cubic feet per minute (113.3 L/min) per 100 square feet (9.29 m²) of conditioned floor area.

R403.3.5 Building cavities (Mandatory). *Building* framing cavities shall not be used as ducts or plenums.

R403.3.6 Ducts buried within ceiling insulation. Where supply and return air ducts are partially or completely buried in ceiling insulation, such ducts shall comply with all of the following:

1. The supply and return ducts shall have an insulation *R*-value not less than *R*-8.
2. At all points along each duct, the sum of the ceiling insulation *R*-value against and above the top of the duct, and against and below the bottom of the duct, shall be not less than *R*-19, excluding the *R*-value of the duct insulation.
3. In *Climate Zones* 1A, 2A and 3A, the supply ducts shall be completely buried within ceiling insulation, insulated to an *R*-value of not less than *R*-13 and in compliance with the vapor retarder requirements of Section 604.11 of the *International Mechanical Code* or Section M1601.4.6 of the *International Residential Code*, as applicable.

Exception: Sections of the supply duct that are less than 3 feet (914 mm) from the supply outlet shall not be required to comply with these requirements.

approved means of ventilation. Outdoor air intakes and exhausts shall have automatic or gravity dampers that close when the ventilation system is not operating.

R403.6.1 Whole-house mechanical ventilation system fan efficacy. Fans used to provide whole-house mechanical ventilation shall meet the efficacy requirements of Table R403.6.1.

Exception: Where an air handler that is integral to tested and *listed* HVAC equipment is used to provide whole-house mechanical ventilation, the air handler shall be powered by an electronically commutated motor.

R403.7 Equipment sizing and efficiency rating (Mandatory). Heating and cooling equipment shall be sized in accordance with ACCA Manual S based on *building* loads calculated in accordance with ACCA Manual J or other *approved* heating and cooling calculation methodologies. New or replacement heating and cooling equipment shall have an efficiency rating equal to or greater than the minimum required by federal law for the geographic location where the equipment is installed.

R403.8 Systems serving multiple dwelling units (Mandatory). Systems serving multiple dwelling units shall comply with Sections C403 and C404 of the *International Energy Conservation Code—Commercial Provisions* instead of Section R403.

R403.9 Snow melt and ice system controls (Mandatory). Snow- and ice-melting systems, supplied through energy service to the building, shall include automatic controls capable of shutting off the system when the pavement temperature is greater than 50°F (10°C) and precipitation is not falling, and an automatic or manual control that will allow shutoff when the outdoor temperature is greater than 40°F (4.8°C).

R403.10 Pools and permanent spa energy consumption (Mandatory). The energy consumption of pools and permanent spas shall be in accordance with Sections R403.10.1 through R403.10.3.

R403.10.1 Heaters. The electric power to heaters shall be controlled by a readily *accessible* on-off switch that is an integral part of the heater mounted on the exterior of the heater, or external to and within 3 feet (914 mm) of the heater. Operation of such switch shall not change the setting of the heater thermostat. Such switches shall be in addition to a circuit breaker for the power to the heater. Gas-fired heaters shall not be equipped with continuously burning ignition pilots.

R403.10.2 Time switches. Time switches or other control methods that can automatically turn off and on according to a preset schedule shall be installed for heaters and pump motors. Heaters and pump motors that have built-in time switches shall be in compliance with this section.

Exceptions:

1. Where public health standards require 24-hour pump operation.
2. Pumps that operate solar- and waste-heat-recovery pool heating systems.

R403.10.3 Covers. Outdoor heated pools and outdoor permanent spas shall be provided with a vapor-retardant cover or other *approved* vapor-retardant means.

Exception: Where more than 75 percent of the energy for heating, computed over an operation season of not less than three calendar months, is from a heat pump or an on-site renewable energy system, covers or other vapor-retardant means shall not be required.

R403.11 Portable spas (Mandatory). The energy consumption of electric-powered portable spas shall be controlled by the requirements of APSP 14.

R403.12 Residential pools and permanent residential spas. Residential swimming pools and permanent residential spas that are accessory to detached one- and two-family dwellings and townhouses three stories or less in height above grade plane and that are available only to the household and its guests shall be in accordance with APSP 15.

**SECTION R404
ELECTRICAL POWER AND LIGHTING SYSTEMS**

R404.1 Lighting equipment (Mandatory). Not less than 90 percent of the permanently installed lighting fixtures shall contain only high-efficacy lamps.

R404.1.1 Lighting equipment (Mandatory). Fuel gas lighting systems shall not have continuously burning pilot lights.

**SECTION R405
SIMULATED PERFORMANCE ALTERNATIVE
(PERFORMANCE)**

R405.1 Scope. This section establishes criteria for compliance using simulated energy performance analysis. Such

**TABLE R403.6.1
WHOLE-HOUSE MECHANICAL VENTILATION SYSTEM FAN EFFICACY^a**

FAN LOCATION	AIR FLOW RATE MINIMUM (CFM)	MINIMUM EFFICACY (CFM/WATT)	AIR FLOW RATE MAXIMUM (CFM)
HRV or ERV	Any	1.2 cfm/watt	Any
Range hoods	Any	2.8 cfm/watt	Any
In-line fan	Any	2.8 cfm/watt	Any
Bathroom, utility room	10	1.4 cfm/watt	< 90
Bathroom, utility room	90	2.8 cfm/watt	Any

For SI: 1 cfm = 28.3 L/min.

a. When tested in accordance with HVI Standard 916.

TABLE R405.5.2(1)
SPECIFICATIONS FOR THE STANDARD REFERENCE DESIGN AND PROPOSED DESIGNS

BUILDING COMPONENT	STANDARD REFERENCE DESIGN	PROPOSED DESIGN
Above-grade walls	Type: mass, where the proposed wall is a mass wall; otherwise, wood frame.	As proposed
	Gross area: same as proposed.	As proposed
	<i>U</i> -factor: as specified in Table R402.1.4.	As proposed
	Solar absorptance = 0.75.	As proposed
	Emittance = 0.90.	As proposed
Basement and crawl space walls	Type: same as proposed.	As proposed
	Gross area: same as proposed.	As proposed
	<i>U</i> -factor: as specified in Table R402.1.4, with the insulation layer on the interior side of the walls.	As proposed
Above-grade floors	Type: wood frame.	As proposed
	Gross area: same as proposed.	As proposed
	<i>U</i> -factor: as specified in Table R402.1.4.	As proposed
Ceilings	Type: wood frame.	As proposed
	Gross area: same as proposed.	As proposed
	<i>U</i> -factor: as specified in Table R402.1.4.	As proposed
Roofs	Type: composition shingle on wood sheathing.	As proposed
	Gross area: same as proposed.	As proposed
	Solar absorptance = 0.75.	As proposed
	Emittance = 0.90.	As proposed
Attics	Type: vented with an aperture of 1 ft ² per 300 ft ² of ceiling area.	As proposed
Foundations	Type: same as proposed.	As proposed
	Foundation wall area above and below grade and soil characteristics: same as proposed.	As proposed
Opaque doors	Area: 40 ft ² .	As proposed
	Orientation: North.	As proposed
	<i>U</i> -factor: same as fenestration as specified Table R402.1.4.	As proposed
Vertical fenestration other than opaque doors	Total area ^h = (a) The proposed glazing area, where the proposed glazing area is less than 15 percent of the conditioned floor area (b) 15 percent of the conditioned floor area, where the proposed glazing area is 15 percent or more of the conditioned floor area.	As proposed
	Orientation: equally distributed to four cardinal compass orientations (N, E, S & W).	As proposed
	<i>U</i> -factor: as specified in Table R402.1.4.	As proposed
	SHGC: as specified in Table R402.1.2 except for climate zones without an SHGC requirement, the SHGC shall be equal to 0.40.	As proposed
	Interior shade fraction: 0.92-(0.21 × SHGC for the standard reference design).	Interior shade fraction: 0.92-(0.21 × SHGC as proposed)
	External shading: none.	As proposed
Skylights	None.	As proposed
Thermally isolated sunrooms	None.	As proposed
Air exchange rate	The air leakage rate at a pressure of 0.2 inch w.g. (50 Pa) shall be <i>Climate Zones 1 and 2:</i> 5 air changes per hour. <i>Climate Zones 3 through 8:</i> 3 air changes per hour. The mechanical ventilation rate shall be in addition to the air leakage rate and shall be the same as in the proposed design, but not greater than $0.01 \times CFA + 7.5 \times (N_{br} + 1)$ where: <i>CFA</i> = conditioned floor area, ft ² . <i>N_{br}</i> = number of bedrooms. Energy recovery shall not be assumed for mechanical ventilation.	The measured air exchange rate. ^a The mechanical ventilation rate ^b shall be in addition to the air leakage rate and shall be as proposed.

(continued)

TABLE R405.5.2(1)—continued
SPECIFICATIONS FOR THE STANDARD REFERENCE AND PROPOSED DESIGNS

BUILDING COMPONENT	STANDARD REFERENCE DESIGN	PROPOSED DESIGN
Mechanical ventilation	Where mechanical ventilation is not specified in the proposed design: None Where mechanical ventilation is specified in the proposed design, the annual vent fan energy use, in units of kWh/yr, shall equal: $(1/e_f) \times [0.0876 \times CFA + 65.7 \times (N_{br} + 1)]$ where: e_f = the minimum exhaust fan efficacy, as specified in Table R403.6.1, corresponding to a flow rate of $0.01 \times CFA + 7.5 \times (N_{br} + 1)$ CFA = conditioned floor area, ft ² . N_{br} = number of bedrooms.	As proposed
Internal gains	IGain, in units of Btu/day per dwelling unit, shall equal: $17,900 + 23.8 \times CFA + 4,104 \times N_{br}$ where: CFA = conditioned floor area, ft ² . N_{br} = number of bedrooms.	Same as standard reference design.
Internal mass	Internal mass for furniture and contents: 8 pounds per square foot of floor area.	Same as standard reference design, plus any additional mass specifically designed as a thermal storage element ^c but not integral to the building envelope or structure.
Structural mass	For masonry floor slabs: 80 percent of floor area covered by R-2 carpet and pad, and 20 percent of floor directly exposed to room air.	As proposed
	For masonry basement walls: as proposed, but with insulation as specified in Table R402.1.4, located on the interior side of the walls.	As proposed
	For other walls, ceilings, floors, and interior walls: wood frame construction.	As proposed
Heating systems ^{d, e}	For other than electric heating without a heat pump: as proposed. Where the proposed design utilizes electric heating without a heat pump, the standard reference design shall be an air source heat pump meeting the requirements of Section C403 of the IECC—Commercial Provisions. Capacity: sized in accordance with Section R403.7.	As proposed
Cooling systems ^{d, f}	As proposed. Capacity: sized in accordance with Section R403.7.	As proposed
Service water heating ^{d, e, f, g}	As proposed. Use: same as proposed design.	As proposed Use, in units of gal/day = $30 + (10 \times N_{br})$ where: N_{br} = number of bedrooms.
Thermal distribution systems	Duct insulation: in accordance with Section R403.3.1. A thermal distribution system efficiency (DSE) of 0.88 shall be applied to both the heating and cooling system efficiencies for all systems other than tested duct systems. Exception: For nonducted heating and cooling systems that do not have a fan, the standard reference design thermal distribution system efficiency (DSE) shall be 1. For tested duct systems, the leakage rate shall be 4 cfm (113.3 L/min) per 100 ft ² (9.29 m ²) of conditioned floor area at a pressure of differential of 0.1 inch w.g. (25 Pa).	Duct insulation: as proposed. As tested or, where not tested, as specified in Table R405.5.2(2)
Thermostat	Type: Manual, cooling temperature setpoint = 75°F; heating temperature setpoint = 72°F.	Same as standard reference design.

(continued)

TABLE R405.5.2(1)—continued
SPECIFICATIONS FOR THE STANDARD REFERENCE AND PROPOSED DESIGNS

For SI: 1 square foot = 0.93 m², 1 British thermal unit = 1055 J, 1 pound per square foot = 4.88 kg/m², 1 gallon (US) = 3.785 L, °C = (°F - 32)/1.8, 1 degree = 0.79 rad.

- a. Where required by the code official, testing shall be conducted by an approved party. Hourly calculations as specified in the ASHRAE *Handbook of Fundamentals*, or the equivalent, shall be used to determine the energy loads resulting from infiltration.
- b. The combined air exchange rate for infiltration and mechanical ventilation shall be determined in accordance with Equation 43 of 2001 ASHRAE *Handbook of Fundamentals*, page 26.24 and the “Whole-house Ventilation” provisions of 2001 ASHRAE *Handbook of Fundamentals*, page 26.19 for intermittent mechanical ventilation.
- c. Thermal storage element shall mean a component that is not part of the floors, walls or ceilings that is part of a passive solar system, and that provides thermal storage such as enclosed water columns, rock beds, or phase-change containers. A thermal storage element shall be in the same room as fenestration that faces within 15 degrees (0.26 rad) of true south, or shall be connected to such a room with pipes or ducts that allow the element to be actively charged.
- d. For a proposed design with multiple heating, cooling or water heating systems using different fuel types, the applicable standard reference design system capacities and fuel types shall be weighted in accordance with their respective loads as calculated by accepted engineering practice for each equipment and fuel type present.
- e. For a proposed design without a proposed heating system, a heating system having the prevailing federal minimum efficiency shall be assumed for both the standard reference design and proposed design.
- f. For a proposed design home without a proposed cooling system, an electric air conditioner having the prevailing federal minimum efficiency shall be assumed for both the standard reference design and the proposed design.
- g. For a proposed design with a nonstorage-type water heater, a 40-gallon storage-type water heater having the prevailing federal minimum energy factor for the same fuel as the predominant heating fuel type shall be assumed. For a proposed design without a proposed water heater, a 40-gallon storage-type water heater having the prevailing federal minimum efficiency for the same fuel as the predominant heating fuel type shall be assumed for both the proposed design and standard reference design.
- h. For residences with conditioned basements, R-2 and R-4 residences, and for townhouses, the following formula shall be used to determine glazing area:

$$AF = A_s \times FA \times F$$

where:

AF = Total glazing area.

A_s = Standard reference design total glazing area.

FA = (Above-grade thermal boundary gross wall area)/(above-grade boundary wall area + 0.5 × below-grade boundary wall area).

F = (above-grade thermal boundary wall area)/(above-grade thermal boundary wall area + common wall area) or 0.56, whichever is greater.

and where:

Thermal boundary wall is any wall that separates conditioned space from unconditioned space or ambient conditions.

Above-grade thermal boundary wall is any thermal boundary wall component not in contact with soil.

Below-grade boundary wall is any thermal boundary wall in soil contact.

Common wall area is the area of walls shared with an adjoining dwelling unit. L and CFA are in the same units.

TABLE R405.5.2(2)
DEFAULT DISTRIBUTION SYSTEM EFFICIENCIES FOR PROPOSED DESIGNS^a

DISTRIBUTION SYSTEM CONFIGURATION AND CONDITION	FORCED AIR SYSTEMS	HYDRONIC SYSTEMS ^b
Distribution system components located in unconditioned space	—	0.95
Untested distribution systems entirely located in conditioned space ^c	0.88	1
“Ductless” systems ^d	1	—

For SI: 1 cubic foot per minute = 0.47 L/s, 1 square foot = 0.093 m², 1 pound per square inch = 6895 Pa, 1 inch water gauge = 1250 Pa.

- a. Default values in this table are for untested distribution systems, which must still meet minimum requirements for duct system insulation.
- b. Hydronic systems shall mean those systems that distribute heating and cooling energy directly to individual spaces using liquids pumped through closed-loop piping and that do not depend on ducted, forced airflow to maintain space temperatures.
- c. Entire system in conditioned space shall mean that no component of the distribution system, including the air-handler unit, is located outside of the conditioned space.
- d. Ductless systems shall be allowed to have forced airflow across a coil but shall not have any ducted airflow external to the manufacturer’s air-handler enclosure.

R405.6 Calculation software tools. Calculation software, where used, shall be in accordance with Sections R405.6.1 through R405.6.3.

R405.6.1 Minimum capabilities. Calculation procedures used to comply with this section shall be software tools capable of calculating the annual energy consumption of all building elements that differ between the *standard reference design* and the *proposed design* and shall include the following capabilities:

1. Computer generation of the *standard reference design* using only the input for the *proposed design*. The calculation procedure shall not allow the user to directly modify the building component characteristics of the *standard reference design*.
2. Calculation of whole-building (as a single *zone*) sizing for the heating and cooling equipment in the *standard reference design* residence in accordance with Section R403.6.
3. Calculations that account for the effects of indoor and outdoor temperatures and part-load ratios on the performance of heating, ventilating and air-conditioning equipment based on climate and equipment sizing.
4. Printed *code official* inspection checklist listing each of the *proposed design* component characteristics from Table R405.5.2(1) determined by the analysis to provide compliance, along with their respective performance ratings such as *R*-value, *U*-factor, SHGC, HSPF, AFUE, SEER and EF.

R405.6.2 Specific approval. Performance analysis tools meeting the applicable provisions of Section R405 shall be permitted to be *approved*. Tools are permitted to be *approved* based on meeting a specified threshold for a jurisdiction. The *code official* shall be permitted to approve such tools for a specified application or limited scope.

R405.6.3 Input values. When calculations require input values not specified by Sections R402, R403, R404 and R405, those input values shall be taken from an *approved* source.

SECTION R406 ENERGY RATING INDEX COMPLIANCE ALTERNATIVE

R406.1 Scope. This section establishes criteria for compliance using an Energy Rating Index (ERI) analysis.

R406.2 Mandatory requirements. Compliance with this section requires that the provisions identified in Sections R401 through R404 indicated as “Mandatory” and Section R403.5.3 be met. The *building thermal envelope* shall be greater than or equal to levels of efficiency and *Solar Heat Gain Coefficients* in Table 402.1.1 or 402.1.3 of the 2009 *International Energy Conservation Code*.

Exception: Supply and return ducts not completely inside the *building thermal envelope* shall be insulated to an *R*-value of not less than R-6.

R406.3 Energy Rating Index. The Energy Rating Index (ERI) shall be determined in accordance with RESNET/ICC 301 except for buildings covered by the *International Residential Code*, the ERI Reference Design Ventilation rate shall be in accordance with Equation 4-1.

Ventilation rate, CFM = $(0.01 \times \text{total square foot area of house}) + [7.5 \times (\text{number of bedrooms} + 1)]$
(Equation 4-1)

Energy used to recharge or refuel a vehicle used for transportation on roads that are not on the building site shall not be included in the *ERI reference design* or the *rated design*.

R406.4 ERI-based compliance. Compliance based on an ERI analysis requires that the *rated design* be shown to have an ERI less than or equal to the appropriate value indicated in Table R406.4 when compared to the *ERI reference design*.

TABLE R406.4
MAXIMUM ENERGY RATING INDEX

CLIMATE ZONE	ENERGY RATING INDEX ^a
1	57
2	57
3	57
4	62
5	61
6	61
7	58
8	58

a. Where on-site renewable energy is included for compliance using the ERI analysis of Section R406.4, the building shall meet the mandatory requirements of Section R406.2, and the building thermal envelope shall be greater than or equal to the levels of efficiency and SHGC in Table R402.1.2 or Table R402.1.4 of the 2015 *International Energy Conservation Code*.

R406.5 Verification by approved agency. Verification of compliance with Section R406 shall be completed by an *approved* third party.

R406.6 Documentation. Documentation of the software used to determine the ERI and the parameters for the *residential building* shall be in accordance with Sections R406.6.1 through R406.6.3.

R406.6.1 Compliance software tools. Software tools used for determining ERI shall be *Approved Software Rating Tools* in accordance with RESNET/ICC 301.

R406.6.2 Compliance report. Compliance software tools shall generate a report that documents that the ERI of the *rated design* complies with Sections R406.3 and R406.4. The compliance documentation shall include the following information:

1. Address or other identification of the residential building.
2. An inspection checklist documenting the building component characteristics of the *rated design*. The inspection checklist shall show results for both the *ERI reference design* and the *rated design*, and shall document all inputs entered by the user necessary to reproduce the results.

CHAPTER 5 [RE]

EXISTING BUILDINGS

User note:

About this chapter: Many buildings are renovated or altered in numerous ways that could affect the energy use of the building as a whole. Chapter 5 requires the application of certain parts of Chapter 4 in order to maintain, if not improve, the conservation of energy by the renovated or altered building.

SECTION R501 GENERAL

R501.1 Scope. The provisions of this chapter shall control the *alteration, repair, addition* and change of occupancy of existing *buildings* and structures.

R501.1.1 Additions, alterations, or repairs: General. *Additions, alterations, or repairs* to an existing *building, building system* or portion thereof shall comply with Section R502, R503 or R504. Unaltered portions of the existing *building* or *building supply system* shall not be required to comply with this code.

R501.2 Existing buildings. Except as specified in this chapter, this code shall not be used to require the removal, *alteration* or abandonment of, nor prevent the continued use and maintenance of, an existing *building* or *building system* lawfully in existence at the time of adoption of this code.

R501.3 Maintenance. *Buildings* and structures, and parts thereof, shall be maintained in a safe and sanitary condition. Devices and systems that are required by this code shall be maintained in conformance to the code edition under which installed. The owner or the owner's authorized agent shall be responsible for the maintenance of *buildings* and structures. The requirements of this chapter shall not provide the basis for removal or abrogation of energy conservation, fire protection and safety systems and devices in existing structures.

R501.4 Compliance. *Alterations, repairs, additions* and changes of occupancy to, or relocation of, existing *buildings* and structures shall comply with the provisions for *alterations, repairs, additions* and changes of occupancy or relocation, respectively, in this code and the *International Residential Code, International Building Code, International Existing Building Code, International Fire Code, International Fuel Gas Code, International Mechanical Code, International Plumbing Code, International Property Maintenance Code, International Private Sewage Disposal Code* and NFPA 70.

R501.5 New and replacement materials. Except as otherwise required or permitted by this code, materials permitted by the applicable code for new construction shall be used. Like materials shall be permitted for *repairs*, provided that hazards to life, health or property are not created. Hazardous materials shall not be used where the code for new construction would not allow their use in *buildings* of similar occupancy, purpose and location.

R501.6 Historic buildings. Provisions of this code relating to the construction, *repair, alteration, restoration* and movement of structures, and *change of occupancy* shall not be mandatory for *historic buildings* provided that a report has been submitted to the *code official* and signed by the owner, a *registered design professional*, or a representative of the State Historic Preservation Office or the historic preservation authority having jurisdiction, demonstrating that compliance with that provision would threaten, degrade or destroy the historic form, fabric or function of the *building*.

SECTION R502 ADDITIONS

R502.1 General. *Additions* to an existing *building, building system* or portion thereof shall conform to the provisions of this code as those provisions relate to new construction without requiring the unaltered portion of the existing *building* or *building system* to comply with this code. *Additions* shall not create an unsafe or hazardous condition or overload existing *building systems*. An *addition* shall be deemed to comply with this code where the *addition* alone complies, where the existing *building* and *addition* comply with this code as a single *building*, or where the *building* with the *addition* does not use more energy than the existing *building*. *Additions* shall be in accordance with Section R502.1.1 or R502.1.2.

R502.1.1 Prescriptive compliance. *Additions* shall comply with Sections R502.1.1.1 through R502.1.1.4.

R502.1.1.1 Building envelope. New *building envelope assemblies* that are part of the *addition* shall comply with Sections R402.1, R402.2, R402.3.1 through R402.3.5, and R402.4.

Exception: Where *unconditioned space* is changed to *conditioned space*, the *building envelope* of the addition shall comply where the Total UA, as determined in Section R402.1.5, of the existing *building* and the *addition*, and any *alterations* that are part of the project, is less than or equal to the Total UA generated for the existing *building*.

R502.1.1.2 Heating and cooling systems. New heating, cooling and duct systems that are part of the *addition* shall comply with Section R403.

Exception: Where ducts from an existing heating and cooling system are extended to an *addition*, duct

EXISTING BUILDINGS

systems with less than 40 linear feet (12.19 m) in *unconditioned spaces* shall not be required to be tested in accordance with Section R403.3.3.

R502.1.1.3 Service hot water systems. New service hot water systems that are part of the *addition* shall comply with Section R403.4.

R502.1.1.4 Lighting. New lighting systems that are part of the *addition* shall comply with Section R404.1.

R502.1.2 Existing plus addition compliance (Simulated Performance Alternative). Where *unconditioned space* is changed to *conditioned space*, the *addition* shall comply where the annual energy cost or energy use of the *addition* and the existing *building*, and any *alterations* that are part of the project, is less than or equal to the annual energy cost of the existing *building* when modeled in accordance with Section R405. The *addition* and any *alterations* that are part of the project shall comply with Section R405 in its entirety.

SECTION R503 ALTERATIONS

R503.1 General. *Alterations* to any *building* or structure shall comply with the requirements of the code for new construction. *Alterations* shall be such that the existing *building* or structure is not less conforming to the provisions of this code than the existing *building* or structure was prior to the *alteration*.

Alterations to an existing *building*, *building* system or portion thereof shall conform to the provisions of this code as they relate to new construction without requiring the unaltered portions of the existing *building* or *building* system to comply with this code. *Alterations* shall not create an unsafe or hazardous condition or overload existing building systems. *Alterations* shall be such that the existing *building* or structure does not use more energy than the existing *building* or structure prior to the *alteration*. *Alterations* to existing *buildings* shall comply with Sections R503.1.1 through R503.2.

R503.1.1 Building envelope. *Building* envelope assemblies that are part of the *alteration* shall comply with Section R402.1.2 or R402.1.4, Sections R402.2.1 through R402.2.13, R402.3.1, R402.3.2, R402.4.3 and R402.4.5.

Exception: The following *alterations* shall not be required to comply with the requirements for new construction provided that the energy use of the *building* is not increased:

1. Storm windows installed over existing fenestration.
2. Existing ceiling, wall or floor cavities exposed during construction provided that these cavities are filled with insulation.
3. Construction where the existing roof, wall or floor cavity is not exposed.
4. Roof re-cover.

5. Roofs without insulation in the cavity and where the sheathing or insulation is exposed during reroofing shall be insulated either above or below the sheathing.

6. Surface-applied window film installed on existing single pane fenestration assemblies to reduce solar heat gain provided that the code does not require the glazing or fenestration assembly to be replaced.

R503.1.1.1 Replacement fenestration. Where some or all of an existing fenestration unit is replaced with a new fenestration product, including sash and glazing, the replacement fenestration unit shall meet the applicable requirements for *U*-factor and SHGC as specified Table R402.1.2. Where more than one replacement *fenestration* unit is to be installed, an area-weighted average of the *U*-factor, SHGC or both of all replacement *fenestration* units shall be an alternative that can be used to show compliance.

R503.1.2 Heating and cooling systems. New heating, cooling and duct systems that are part of the *alteration* shall comply with Section R403.

Exception: Where ducts from an existing heating and cooling system are extended, duct systems with less than 40 linear feet (12.19 m) in *unconditioned spaces* shall not be required to be tested in accordance with Section R403.3.3.

R503.1.3 Service hot water systems. New service hot water systems that are part of the *alteration* shall comply with Section R403.5.

R503.1.4 Lighting. New lighting systems that are part of the *alteration* shall comply with Section R404.1.

Exception: *Alterations* that replace less than 50 percent of the luminaires in a space, provided that such *alterations* do not increase the installed interior lighting power.

R503.2 Change in space conditioning. Any nonconditioned or low-energy space that is altered to become *conditioned space* shall be required to be brought into full compliance with this code.

Exception: Where the simulated performance option in Section R405 is used to comply with this section, the annual energy cost of the *proposed design* is permitted to be 110 percent of the annual energy cost otherwise allowed by Section R405.3.

SECTION R504 REPAIRS

R504.1 General. *Buildings*, structures and parts thereof shall be repaired in compliance with Section R501.3 and this section. Work on nondamaged components necessary for the required *repair* of damaged components shall be considered to be part of the *repair* and shall not be subject to the requirements for *alterations* in this chapter. Routine maintenance

required by Section R501.3, ordinary *repairs* exempt from *permit*, and abatement of wear due to normal service conditions shall not be subject to the requirements for *repairs* in this section.

R504.2 Application. For the purposes of this code, the following shall be considered to be *repairs*:

1. Glass-only replacements in an existing sash and frame.
2. Roof *repairs*.
3. *Repairs* where only the bulb, ballast or both within the existing luminaires in a space are replaced provided that the replacement does not increase the installed interior lighting power.

SECTION R505 CHANGE OF OCCUPANCY OR USE

R505.1 General. Spaces undergoing a change in occupancy that would result in an increase in demand for either fossil fuel or electrical energy shall comply with this code.

R505.2 General. Any space that is converted to a dwelling unit or portion thereof from another use or occupancy shall comply with this code.

Exception: Where the simulated performance option in Section R405 is used to comply with this section, the annual energy cost of the *proposed design* is permitted to be 110 percent of the annual energy cost allowed by Section R405.3.

CHAPTER 6 [RE]

REFERENCED STANDARDS

User note:

About this chapter: This code contains numerous references to standards promulgated by other organizations that are used to provide requirements for materials and methods of construction. Chapter 6 contains a comprehensive list of all standards that are referenced in this code. These standards, in essence, are part of this code to the extent of the reference to the standard.

This chapter lists the standards that are referenced in various sections of this document. The standards are listed herein by the promulgating agency of the standard, the standard identification, the effective date and title, and the section or sections of this document that reference the standard. The application of the referenced standards shall be as specified in Section R107.

AAMA

American Architectural Manufacturers Association
1827 Walden Office Square
Suite 550
Schaumburg, IL 60173-4268

AAMA/WDMA/CSA 101/I.S.2/A C440—17: North American Fenestration Standard/Specifications for Windows, Doors and Unit Skylights
R402.4.3

ACCA

Air Conditioning Contractors of America
2800 Shirlington Road, Suite 300
Arlington, VA 22206

Manual J—16: Residential Load Calculation Eighth Edition
R403.7

Manual S—14: Residential Equipment Selection
R403.7

APSP

The Association of Pool & Spa Professionals
2111 Eisenhower Avenue, Suite 500
Alexandria, VA 22314

ANSI/APSP/ICC 14—2014: American National Standard for Portable Electric Spa Energy Efficiency
R403.11

ANSI/APSP/ICC 15a—2011: American National Standard for Residential Swimming Pool and Spa Energy Efficiency—includes Addenda A Approved January 9, 2013
R403.12

ASHRAE

ASHRAE
1791 Tullie Circle NE
Atlanta, GA 30329

ASHRAE—2017: ASHRAE Handbook of Fundamentals
R402.1.5

ASHRAE—2001: 2001 ASHRAE Handbook of Fundamentals
Table R405.5.2(1)

ASHRAE 193—2010(RA 2014): Method of Test for Determining the Airtightness of HVAC Equipment
R403.3.2.1

ASTM

ASTM International
100 Barr Harbor Drive, P.O. Box C700
West Conshohocken, PA 19428-2959

C1363—11: Standard Test Method for Thermal Performance of Building Materials and Envelope Assemblies by Means of a Hot Box Apparatus
R303.1.4.1

REFERENCED STANDARDS

ASTM—continued

- E283—04(2012): Test Method for Determining the Rate of Air Leakage Through Exterior Windows, Curtain Walls and Doors Under Specified Pressure Differences Across the Specimen**
R402.4.4
- E779—10: Standard Test Method for Determining Air Leakage Rate by Fan Pressurization**
R402.4.1.2
- E1827—11: Standard Test Methods for Determining Airtightness of Building Using an Orifice Blower Door**
R402.4.1.2

CSA

CSA Group
8501 East Pleasant Valley Road
Cleveland, OH 44131-5516

- AAMA/WDMA/CSA 101/LS.2/A440—17: North American Fenestration Standard/Specification for Windows, Doors and Unit Skylights**
R402.4.3
- CSA B55.1—2015: Test Method for Measuring Efficiency and Pressure Loss of Drain Water Heat Recovery Units**
R403.5.4
- CSA B55.2—2015: Drain Water Heat Recovery Units**
R403.5.4

DASMA

Door & Access Systems Manufacturers Association
1300 Sumner Avenue
Cleveland, OH 44115-2851

- 105—2016: Test Method for Thermal Transmittance and Air Infiltration of Garage Doors and Rolling Doors**
R303.1.3

HVI

Home Ventilating Institute
1000 North Rand Road, Suite 214
Wauconda, IL 60084

- 916—09: Airflow Test Procedure**
Table R403.6.1

ICC

International Code Council, Inc.
500 New Jersey Avenue NW
6th Floor
Washington, DC 20001

- ANSI/APSP/ICC 14—2014: American National Standard for Portable Electric Spa Energy Efficiency**
R403.11
- ANSI/APSP/ICC 15a—2011: American National Standard for Residential Swimming Pool and Spa Energy Efficiency—includes Addenda A Approved January 9, 2013**
R403.12
- IBC—18: International Building Code®**
R201.3, R303.1.1, R303.2, R402.1.1, R501.4
- ICC 400—17: Standard on the Design and Construction of Log Structures**
R402.1, Table R402.5.1.1
- IEBC—18: International Existing Building Code®**
R501.4
- IECC—18: International Energy Conservation Code®**
R101.4.1, R403.8
- IECC—15: 2015 International Energy Conservation Code®**
Table R406.4
- IECC—09: 2009 International Energy Conservation Code®**
R406.2

ICC—continued

IECC—06: 2006 International Energy Conservation Code®
R202

IFC—18: International Fire Code®
R201.3, R501.4

IFGC—18: International Fuel Gas Code®
R201.3, R501.4

IMC—18: International Mechanical Code®
R201.3, R403.3.2, R403.3.6, R403.6, R501.4

IPC—18: International Plumbing Code®
R201.3, R501.4

IPSDC—18: International Private Sewage Disposal Code®
R501.4

IPMC—18: International Property Maintenance Code®
R501.4

IRC—18: International Residential Code®
R201.3, R303.1.1, R303.2, R402.1.1, R402.2.11, R403.3.2, R403.3.6, R403.6, R501.4

ANSI/RESNET/ICC 301—2014: Standard for the Calculation and Labeling of the Energy Performance of Low-rise Residential Buildings using an Energy Rating Index First Published March 7, 2014—Republished January 2016
R406.3

ANSI/RESNET/ICC 380—2016: Standard for Testing Airtightness for Building Enclosures, Airtightness of Heating and Cooling Air Distribution Systems and Airflow of Mechanical Ventilation Systems—Republished January 2016
R402.4.1.2

IEEE

Institute of Electrical and Electronic Engineers, Inc.
3 Park Avenue, 17th Floor
New York, NY 10016-5997

515.1—2012: IEEE Standard for the Testing, Design, Installation and Maintenance of Electrical Resistance Trace Heating for Commercial Applications
R403.5.1.2

NFPA

National Fire Protection Association
1 Batterymarch Park
Quincy, MA 02169-7471

70—17: National Electrical Code
R501.4

NFRC

National Fenestration Rating Council, Inc.
6305 Ivy Lane, Suite 140
Greenbelt, MD 20770

100—2017: Procedure for Determining Fenestration Products *U*-factors
R303.1.3

200—2017: Procedure for Determining Fenestration Product Solar Heat Gain Coefficients and Visible Transmittance at Normal Incidence
R303.1.3

400—2017: Procedure for Determining Fenestration Product Air Leakage
R402.4.3

RESNET

Residential Energy Services Network, Inc.
P.O. Box 4561
Oceanside, CA 92052-4561

ANSI/RESNET/ICC 301—2014: Standard for the Calculation and Labeling of the Energy Performance of Low-rise Residential Buildings using an Energy Rating Index First Published March 7, 2014—Republished January 2016
R406.3, R406.6.1, R406.6.5

REFERENCED STANDARDS

RESNET—continued

ANSI/RESNET/ICC 380—2016: Standard for Testing Airtightness for Building Enclosures, Airtightness of Heating and Cooling Air Distribution Systems, and Airflow of Mechanical Ventilation Systems—Republished January 2016
R402.4.1.2

UL

UL LLC
333 Pfingsten Road
Northbrook, IL 60062

127—11: Standard for Factory Built Fireplaces—with Revisions through May 2015
R402.4.2

515—11: Electrical Resistance Heat Tracing for Commercial and Industrial Applications Including Revisions through July 2015
R403.5.1.2

US-FTC

United States-Federal Trade Commission
600 Pennsylvania Avenue NW
Washington, DC 20580

CFR Title 16 (2015): R-value Rule
R303.1.4

WDMA

Window and Door Manufacturers Association
2025 M Street NW, Suite 800
Washington, DC 20036-3309

AAMA/WDMA/CSA 101/I.S.2/A440—17: North American Fenestration Standard/Specification for Windows, Doors and Unit Skylights
R402.4.3

APPENDIX RA

SOLAR-READY PROVISIONS—DETACHED ONE- AND TWO-FAMILY DWELLINGS AND TOWNHOUSES

The provisions contained in this appendix are not mandatory unless specifically referenced in the adopting ordinance.

User note:

About this appendix: Harnessing the heat or radiation from the sun's rays is a method to reduce the energy consumption of a building. Although Appendix RA does not require solar systems to be installed for a building, it does require the space(s) for installing such systems, providing pathways for connections and requiring adequate structural capacity of roof systems to support the systems.

SECTION RA101 SCOPE

RA101.1 General. These provisions shall be applicable for new construction where solar-ready provisions are required.

SECTION RA102 GENERAL DEFINITION

SOLAR-READY ZONE. A section or sections of the roof or building overhang designated and reserved for the future installation of a solar photovoltaic or solar thermal system.

SECTION RA103 SOLAR-READY ZONE

RA103.1 General. New detached one- and two-family dwellings, and townhouses with not less than 600 square feet (55.74 m²) of roof area oriented between 110 degrees and 270 degrees of true north shall comply with Sections RA103.2 through RA103.8.

Exceptions:

1. New residential buildings with a permanently installed on-site renewable energy system.
2. A building with a solar-ready zone that is shaded for more than 70 percent of daylight hours annually.

RA103.2 Construction document requirements for solar-ready zone. Construction documents shall indicate the solar-ready zone.

RA103.3 Solar-ready zone area. The total solar-ready zone area shall be not less than 300 square feet (27.87 m²) exclusive of mandatory access or set back areas as required by the *International Fire Code*. New townhouses three stories or less in height above grade plane and with a total floor area less than or equal to 2,000 square feet (185.8 m²) per dwelling shall have a solar-ready zone area of not less than 150 square feet (13.94 m²). The solar-ready zone shall be composed of areas not less than 5 feet (1524 mm) in width and not less than 80 square feet (7.44 m²) exclusive of access or set back areas as required by the *International Fire Code*.

RA103.4 Obstructions. Solar-ready zones shall be free from obstructions, including but not limited to vents, chimneys, and roof-mounted equipment.

RA103.5 Roof load documentation. The structural design loads for roof dead load and roof live load shall be clearly indicated on the construction documents.

RA103.6 Interconnection pathway. Construction documents shall indicate pathways for routing of conduit or plumbing from the solar-ready zone to the electrical service panel or service hot water system.

RA103.7 Electrical service reserved space. The main electrical service panel shall have a reserved space to allow installation of a dual pole circuit breaker for future solar electric installation and shall be labeled "For Future Solar Electric." The reserved space shall be positioned at the opposite (load) end from the input feeder location or main circuit location.

RA103.8 Construction documentation certificate. A permanent certificate, indicating the solar-ready zone and other requirements of this section, shall be posted near the electrical distribution panel, water heater or other conspicuous location by the builder or registered design professional.

INDEX

A

ACCESS HATCHES	R402.2.4
ADDITION	
Defined	R202
Requirements	R501.1.1, R502
ALTERATION	
Defined	R202
Requirements	503
ADMINISTRATION	Chapter 1
AIR BARRIER	
Installation	R402.4.1.1, Table R402.4.1.1
Testing	R402.4.1.2
AIR INFILTRATION	
Requirements	R402.4.1.2
AIR LEAKAGE	R402.4, R403.3.3, R403.3.4
ALTERNATE MATERIALS	R102
APPROVED	
Defined	R202
AUTOMATIC	
Defined	R202
ATMOSPHERIC VENTING	Appendix RA
Worst-case testing	RA301

B

BASEMENT WALL	
Defined	R202
Requirements	R303.2.1, Table R402.1.2, R402.2.9, Table R405.5.2(1)
BELOW-GRADE WALLS (see BASEMENT WALLS)	
BOARD OF APPEALS	R109
Qualifications of members	R109.3
BUILDING	
Defined	R202
BUILDING THERMAL ENVELOPE	
Air tightness	R402.4.1
Compliance documentation	R103.2, R401.3
Defined	R202
Insulation	R303.1.1
Insulation and fenestration criteria	R402.1.2
Performance method	Table R405.5.2(1)
Requirements	R102.1.1, R402

C

CEILING	R402.2.1, R402.2.1, R402.2.2
Specification for standard reference design	Table R405.5.2(1)
CERTIFICATE	R401.3

D

CHANGE OF OCCUPANCY	R505
CIRCULATION SYSTEMS	R403.5.1
CLIMATE TYPES	
Defined	Table R301.3(1)
CLIMATE ZONES	R301, Figure R301.1, Table R301.1
By state or territory	Figure R301.1, Table R301.1
International climate zones	R301.3, Table R301.3(1), Table R301.3(2)
Tropical	R301.4
Warm humid	R301.2, Table R301.1, Table R301.3(1)
CODE OFFICIAL	
Defined	R202
COMMERCIAL BUILDING	
Compliance	R101.5
Defined	R202
COMPLIANCE AND ENFORCEMENT	R101.5
Compliance Report	R405.4.2.2
CONDITIONED FLOOR AREA	
Defined	R202
CONDITIONED SPACE	
Defined	R202
CONSTRUCTION DOCUMENTS	R103
Amended	R103.4
Approval	R103.3.1
Examination	R103.3
Information required	R103.2
Phased	R103.3.3
Previous	R103.3.2
Retention	R103.5
Thermal envelope depiction	R103.2.1
CONTINUOUS AIR BARRIER	
Defined	R202
CONTROLS	
Heat pump	R403.1.2
Heating and cooling	R403.1
Service water heating	R403.5
CRAWL SPACE WALL	
Defined	R202
Requirements	R303.2.1, Table R402.1.2, Table R402.1.4, R402.1.4, R402.2.11, Table R405.5.2(1)
DEFAULT DISTRIBUTION SYSTEM EFFICIENCIES	Table R405.5.2(2)
DEFINITIONS	Chapter 2

BENEFITS THAT WORK FOR YOU

No matter where you are in your building career, put the benefits of ICC Membership to work for you!

Membership in ICC connects you to exclusive I-Codes resources, continuing education opportunities and *Members-Only* benefits that include:

- Free code opinions from I-Codes experts
- Free I-Code book(s) or download to new Members*
- Discounts on I-Code resources, training and certification renewal
- Posting resumes and job search openings through the ICC Career Center
- Mentoring programs and valuable networking opportunities at ICC events
- Free benefits — Corporate and Governmental Members: Your staff can receive free ICC benefits too*
- *Savings of up to 25% on code books and training materials and more*

Put the benefits of ICC Membership to work for you and your career. Visit www.iccsafe.org/mem3 to join now or to renew your Membership. Or call 1-888-ICC-SAFE (422-7233), ext. 33804 to learn more today!



* Some restrictions apply. Speak with an ICC Member Services Representative for details.

16-12897

Specify and Approve with

CONFIDENCE



When facing new or unfamiliar materials, how do you know if they comply with building codes and standards?

ICC-ES® **Evaluation Reports** are the most widely accepted and trusted technical reports for code compliance.

ICC-ES **Building Product Listings** and **PMG Listings** show product compliance with applicable standard(s) referenced in the building and plumbing codes as well as other applicable codes.

ICC-ES provides a one-stop shop for the evaluation, listing and now testing of innovative building products through our newly formed cooperation with Innovation Research Labs, a highly respected ISO 17025 accredited testing lab with over 50 years of experience.

ICC-ES is a subsidiary of ICC®, the publisher of the codes used throughout the U.S. and many global markets, so you can be confident in their code expertise.

www.icc-es.org | 800-423-6587 x3877



Look for the ICC-ES Marks of Conformity





SOLAR RATING
& CERTIFICATION
CORPORATION

A member of the ICC
Family of Companies

ICC-SRCC

The industry experts in Clean and Renewable Energy since 1980, ICC-SRCC fulfills the industry's need for a single, national program that allows manufacturers to rate and test the efficiency of solar equipment.

Its primary purpose is to provide authoritative performance ratings, certifications and standards for renewable energy products, with the intention of protecting and providing guidance to consumers, incentive providers, government, and industry.

The corporation is a non-profit, accredited independent third-party certification entity that is wholly funded through fees paid by participants and users. It is unique in that it is the only national certification program established solely for solar thermal products. It is also the only national certification organization whose programs are the direct result of the combined efforts of state organizations and an industry association involved in the administration of standards.

ICC-SRCC PROGRAMS PROVIDE:

- Standardized comparisons of solar thermal product performance
- Certification to SRCC performance standards
- National recognition
- Product credibility

ICC-SRCC BENEFITS INCLUDE:

- A national, state-of-the-art performance rating system
- A mechanism to develop consumer confidence
- Rational, defensible criteria for tax credit qualifications and other solar incentive programs

GROUPS SERVED:

- Consumers
- The Solar Heating & Cooling Industry
- Local, state and federal regulatory bodies



ICC-SRCC's Small Wind Certification Program

Independent Accredited Certification of Wind Turbines

Designed to promote consumer confidence and mainstream acceptance of small and medium wind technology, ICC-SRCC certification standardizes North American reporting of turbine energy and sound performance. ICC-SRCC issues to certified turbines easy-to-understand labels with Rated Annual Energy Output, Rated Power, and Rated Sound Level. The labels also confirm that certified turbines meet durability and safety requirements of the AWEA Standard. ICC-SRCC publishes Power Curves, Annual Energy Performance Curves, measured sound pressure levels, and other technical information for each model certified.

BENEFITS FOR CONSUMERS

- Comparison shopping
- Ratings on easy-to-understand labels and reports
- Established pathways to qualify for incentives

BENEFITS FOR SUPPLIERS

- Increased mainstream credibility
- Conformity with performance and safety standards
- Published power curves and sound levels

Need more information? Contact Solar Rating & Certification Corporation today!

www.solar-rating.org | 1-888-422-7233, x7735 | 202-370-1800

17-14097

GET IMMEDIATE DOWNLOADS OF THE STANDARDS YOU NEED

*Browse hundreds of industry standards adopted by
reference. Available to you 24/7!*

Count on ICC for standards from a variety of publishers,
including:

ACI
AISC
ANSI
APA
APSP
ASHRAE
ASTM
AWC

CPSC
CSA
DOC
DOJ
DOL
DOTn
FEMA
GBI

GYPSUM
HUD
ICC
ISO
NSF
SMACNA
USC

**DOWNLOAD YOUR STANDARDS TODAY!
SHOP.ICCSAFE.ORG**

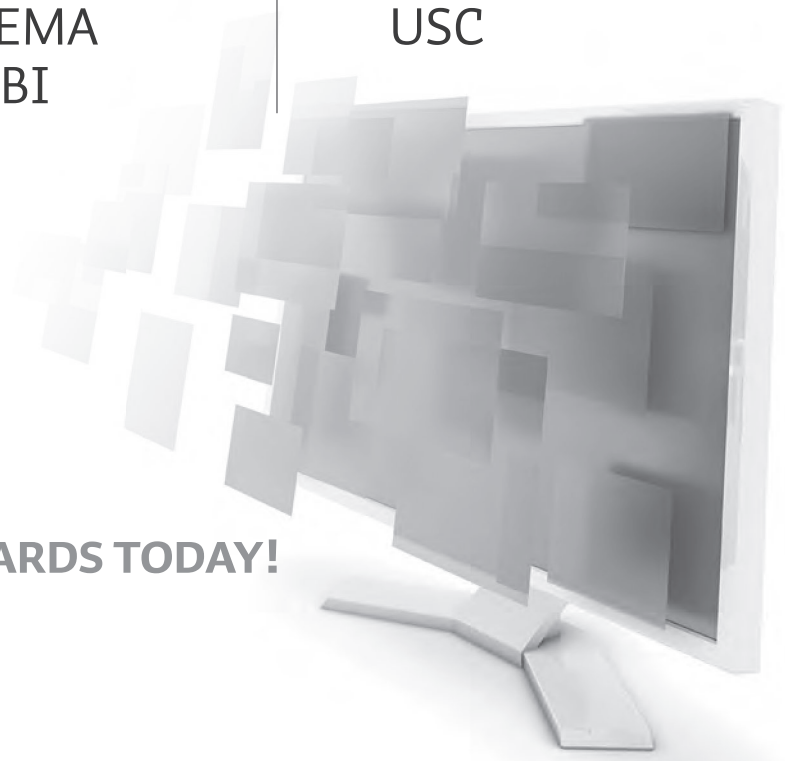

2 0 1 8

INTERNATIONAL CODES®

IgCC®

A Member of the International Code Family

POWERED BY

ANSI/ASHRAE/ICC/USGBC/IES 189.1-2017
Standard for the Design of High-Performance
Green Buildings Except Low-Rise Residential Buildings



INTERNATIONAL
GREEN CONSTRUCTION CODE®



The American
Institute
of Architects



2 0 1 8

INTERNATIONAL CODES®

2018 I-CODE BONUS OFFER

Get a **free 45-day online subscription** to ICC's *premiumACCESS™* 2018 I-Codes Complete Collection. Test drive many powerful, time-saving tools available to you from *premiumACCESS*. To activate your bonus, visit www.iccsafe.org/codebonus.

IgCC®

A Member of the International Code Family®

POWERED BY

ANSI/ASHRAE/ICC/USGBC/IES 189.1-2017
Standard for the Design of High-Performance
Green Buildings Except Low-Rise Residential Buildings



INTERNATIONAL GREEN CONSTRUCTION CODE®

A Comprehensive Solution for High-Performance Buildings



The American
Institute
of Architects



2018 International Green Construction Code®

First Printing: September 2018

ISBN: 978-1-60983-756-3

COPYRIGHT © 2018
by
INTERNATIONAL CODE COUNCIL, INC.
and
ASHRAE

ALL RIGHTS RESERVED. This 2018 *International Green Construction Code*® is a copyrighted work owned by the International Code Council, Inc. (ICC) and ASHRAE. Without advance written permission from the ICC or ASHRAE, no part of this book may be reproduced, distributed or transmitted in any form or by any means, including, without limitation, electronic, optical or mechanical means (by way of example, and not limitation, photocopying or recording by or in an information storage retrieval system). For information on use rights and permissions, please contact: ICC Publications, 4051 Flossmoor Road, Country Club Hills, IL 60478. Phone 1-888-ICC-SAFE (422-7233).

Trademarks: “International Code Council,” the “International Code Council” logo, “ICC,” the “ICC” logo, “International Green Construction Code,” the “IgCC” and other names and trademarks appearing in this book are registered trademarks of the International Code Council, Inc. and/or its licensors (as applicable), and may not be used without permission. “ASHRAE” and the “ASHRAE” logo are registered trademarks of American Society of Heating, Refrigerating and Air-Conditioning Engineers, Inc. and may not be used without permission.

PRINTED IN THE USA

PREFACE

Introduction

Internationally, code officials and designers recognize the need for a modern, up-to-date code governing the impact of buildings and structures on the environment. This code is designed to meet this need through model code regulations that contain clear and specific requirements with provisions that promote safe and sustainable construction in an integrated fashion with the ICC Family of Codes. This 2018 *International Green Construction Code*® (IgCC®) is the first fully integrated edition of the IgCC to be developed cooperatively by ICC and ASHRAE. (See Foreword on page iv.)

This comprehensive green code establishes minimum regulations for building systems and site considerations using prescriptive and performance-related provisions. It is intended to be compatible with all of the International Codes® (I-Codes®) published by the International Code Council® (ICC®), including the *International Building Code*®, *International Energy Conservation Code*®, *International Existing Building Code*®, *International Fire Code*®, *International Fuel Gas Code*®, *International Mechanical Code*®, *International Code Council Performance Code*®, *International Plumbing Code*®, *International Private Sewage Disposal Code*®, *International Property Maintenance Code*®, *International Residential Code*®, *International Swimming Pool and Spa Code*®, *International Wildland-Urban Interface Code*® and *International Zoning Code*®.

This code has been developed in collaboration with the following Cooperating Sponsors: The American Institute of Architects (AIA); ASHRAE; the U.S. Green Building Council (USGBC); and the Illuminating Engineering Society (IES). ICC wishes to thank these Cooperating Sponsors for recognizing the need for the development of a comprehensive set of green regulations that are enforceable, usable and adoptable.

The I-Codes, including this *International Green Construction Code*, are used in a variety of ways in both the public and private sectors. Most industry professionals are familiar with the I-Codes as the basis of laws and regulations in communities across the U.S. and in other countries. However, the impact of the codes extends well beyond the regulatory arena, as they are used in a variety of non-regulatory settings, including:

- Voluntary compliance programs such as those promoting sustainability, energy efficiency and disaster resistance.
- The insurance industry, to estimate and manage risk, and as a tool in underwriting and rate decisions.
- Certification and credentialing of individuals involved in the fields of building design, construction and safety.
- Certification of building and construction-related products.
- U.S. federal agencies, to guide construction in an array of government-owned properties.
- Facilities management.
- “Best practices” benchmarks for designers and builders, including those who are engaged in projects in jurisdictions that do not have a formal regulatory system or a governmental enforcement mechanism.
- College, university and professional school textbooks and curricula.
- Reference works related to building design and construction.

In addition to the codes themselves, the code development process brings together building professionals on a regular basis. It provides an international forum for discussion and deliberation about building design, construction methods, safety, performance requirements, technological advances and innovative products.

Effective Use of the International Green Construction Code

Informative Note: Corresponding ASHRAE 189.1 section numbers have not been included in this Effective Use section but have been included throughout the chapters and appendices of this code.

The *International Green Construction Code*® (IgCC®) is a model code that provides minimum requirements to safeguard the environment, public health, safety and general welfare through the establishment of requirements that are intended to reduce the negative impacts and increase the positive impacts of the built environment on the natural environment and building occupants. The IgCC is fully compatible with the ICC family of codes, including the *International Building Code*® (IBC®), the *International Code Council Performance Code*® (ICCP®), the *International Energy Conservation Code*® (IECC®), the *International Existing Building Code*® (IEBC®), the *International Fire Code*® (IFC®), the *International Fuel Gas Code*® (IFGC®), the *International Mechanical Code*® (IMC®), the *International Plumbing Code*® (IPC®), the *International Private Sewage Disposal Code*® (IPSDC®), the *International Property Maintenance Code*® (IPMC®), the *International Residential Code*® (IRC®), the *International Swimming Pool and Spa Code*® (ISPSC®), the *International Wildland-Urban Interface Code*® (IWUIC®), and the *International Zoning Code*® (IZC®).

The IgCC addresses site sustainability, water and energy efficiency, indoor environmental quality, materials and resources, building commissioning, construction and plans for operations and maintenance for new and certain types of existing buildings, building sites and building materials, components, equipment and systems (see Section 101.3.1). The code will be promulgated on a 3-year cycle to allow for new construction methods and technologies to be incorporated into the code. Innovative approaches and alternative materials, designs, and methods not specifically addressed in this code can be approved by the code official where the proposed innovative approaches or materials, designs or methods comply with the intent of the provisions of the code (see Section 105.4).

The IgCC applies to all occupancies other than single-family dwellings and multifamily dwellings that are three stories or less in height (see Section 101.3.2). See discussion below for additional information in Appendix J for residential construction.

Arrangement and Format of the 2018 IgCC

Before applying the requirements of the IgCC, it is beneficial to understand its arrangement and format.

Chapter	Subjects
1	Scope and administration
2	Reserved
3	Definitions, abbreviations and acronyms
4	Reserved
5	Site sustainability
6	Water use efficiency
7	Energy efficiency
8	Indoor environmental quality (IEQ)
9	Materials and resources
10	Construction and plans for operation
11	Normative references
Normative Appendix A	Climate zones and prescriptive building envelope and duct insulation tables
Normative Appendix B	Prescriptive equipment efficiency tables for the alternate reduced renewables and increased equipment efficiency approach in Section 701.4.1.1.2 (7.4.1.1.2)
Normative Appendix C	Performance option for energy efficiency
Normative Appendix D	Building concentrations

TABLE OF CONTENTS

CHAPTER 1 SCOPE AND ADMINISTRATION 1	NORMATIVE APPENDIX A
<i>PART 1—SCOPE AND APPLICATION 1</i>	CLIMATE ZONES AND
Section	PRESCRIPTIVE BUILDING
101 General 1	ENVELOPE AND DUCT
102 Applicability 2	INSULATION TABLES 93
<i>PART 2—ADMINISTRATION</i>	NORMATIVE APPENDIX B
<i>AND ENFORCEMENT 2</i>	PRESCRIPTIVE EQUIPMENT
103 Duties and Powers of the Authority	EFFICIENCY TABLES FOR THE
Having Jurisdiction. 2	ALTERNATE REDUCED
104 Construction Documents 2	RENEWABLES AND INCREASED
105 Approval. 2	EQUIPMENT EFFICIENCY
106 Permits 3	APPROACH IN SECTION
107 Inspections 3	701.4.1.1.2 (7.4.1.1.2). 97
108 Board of Appeals 4	NORMATIVE APPENDIX C
109 Certificate of Occupancy 4	PERFORMANCE OPTION FOR
CHAPTER 2 RESERVED 5	ENERGY EFFICIENCY 123
CHAPTER 3 DEFINITIONS, ABBREVIATIONS	NORMATIVE APPENDIX D
AND ACRONYMS 7	BUILDING CONCENTRATIONS . . 127
CHAPTER 4 RESERVED 15	INFORMATIVE APPENDIX E
CHAPTER 5 SITE SUSTAINABILITY 17	BUILDING ENVELOPE TABLES . . 129
CHAPTER 6 WATER USE EFFICIENCY 25	INFORMATIVE APPENDIX F
CHAPTER 7 ENERGY EFFICIENCY 31	INTEGRATED DESIGN 149
CHAPTER 8 INDOOR ENVIRONMENTAL	INFORMATIVE APPENDIX G
QUALITY (IEQ) 51	INFORMATIVE REFERENCES . . . 153
CHAPTER 9 MATERIALS AND RESOURCES 67	INFORMATIVE APPENDIX H
CHAPTER 10 CONSTRUCTION AND	OPTION FOR ENERGY
PLANS FOR OPERATION 71	EFFICIENCY USING THE IECC
CHAPTER 11 NORMATIVE REFERENCES 81	PRESCRIPTIVE COMPLIANCE
	PATH 159
	INFORMATIVE APPENDIX I
	ADDITIONAL GUIDANCE FOR
	FUNCTIONAL AND PERFORMANCE
	TESTING (FPT) AND THE
	COMMISSIONING (CX)
	PROCESS 163

CHAPTER 1

SCOPE AND ADMINISTRATION

PART 1—SCOPE AND APPLICATION

SECTION 101 GENERAL

101.1 Title. These regulations shall be known as the Green Construction Code of [NAME OF JURISDICTION] hereinafter referred to as “this code.”

101.2 (1.) Purpose.

101.2.1 (1.1) The purpose of this code is to provide minimum requirements for the siting, design, construction, and plans for operation of *high-performance green buildings* to: reduce emissions from buildings and building systems; enhance building occupant health and comfort; conserve water resources; protect local biodiversity and ecosystem services; promote sustainable and regenerative materials cycles; enhance building quality; enhance resilience to natural, technological, and human-caused hazards; and support the goal of development that meets the needs of the present without compromising the ability of future generations to meet their own needs.

101.2.2 (1.2) This code is intended to provide the technical basis of mandatory building codes and regulations for *high-performance green buildings* that are broadly adoptable by national and local jurisdictions.

101.3 (2.) Scope.

101.3.1 (2.1) This code contains requirements that address *site sustainability*, water use efficiency, energy efficiency, indoor environmental quality (IEQ), materials and resources, and construction and plans for operation. This code applies only to the following *building projects*:

1. New buildings and their systems.
2. New portions of buildings and their systems.
3. New systems and equipment in existing buildings.
4. Relocated existing buildings and temporary structures where specified in this code.

101.3.2 (2.2) The provisions of this code do not apply to the following:

1. Single-family dwellings.
2. Multifamily dwellings of three stories or fewer above grade.
3. Manufactured houses (mobile homes).

4. Manufactured houses (modular).

5. *Building projects* that use none of the following:

1. Electricity.
2. Fossil fuels.
3. Water.

(Informative note: The provisions in Appendix J for residential and multifamily construction apply where adopted by the authority having jurisdiction.)

101.3.3 (2.3) The requirements in this code shall not be used to circumvent any applicable safety, health, or environmental requirements.

101.4 (4.) Application.

101.4.1 (4.1) General. *Building projects* shall comply with Chapters 5 through 11. Within each of these chapters, *building projects* shall comply with all mandatory provisions (x.3) and, where offered, either the:

1. Prescriptive Option (x.4) or
2. Performance Option (x.5).

101.4.2 (4.1.1) Referenced Standards. The standards referenced in this code and listed in Chapter 11 shall be considered to be part of the requirements of this code to the prescribed extent of such reference. Where differences exist between provisions of this code and a referenced standard, the provisions of this code shall apply. Informative references in Informative Appendix G are cited to acknowledge sources and are not part of this code.

101.4.3 (4.1.2) Normative Appendices. The normative appendices to this code are considered to be integral parts of the mandatory requirements of this code, which for reasons of convenience are placed apart from all other normative elements.

101.4.4 (4.1.3) Informative Appendices. The informative appendices to this code, and informative notes located within this code, contain additional information and are not mandatory or part of this code.

101.4.5 (4.1.4) Referenced Standard Reproduction Annexes. The referenced standard reproduction annexes contain material that is cited in this code but that is contained in another standard. The reference standard reproduction annexes are not part of this code but are included in its publication to facilitate its use.

SECTION 102 APPLICABILITY

102.1 Code conflicts. Where there is a conflict between a general requirement and a specific requirement of this code, the specific requirement shall be applicable. Where, in any specific case, different sections of the code specify different materials, methods of construction or other requirements, the most practical requirement to meet the intent of the code shall govern.

102.2 Other laws. The provisions of this code shall not be deemed to nullify any provisions of local, state or federal law.

102.3 Application of references. References to chapter or section numbers, or to provisions not specifically identified by number, shall be construed to refer to such chapter, section or provision of this code.

102.4 Referenced codes and standards. Where adopted by the authority having jurisdiction, the following codes shall be considered to be part of the requirements of this code: *International Building Code, International Code Council Performance Code, International Energy Conservation Code, International Existing Building Code, International Fire Code, International Fuel Gas Code, International Mechanical Code, International Plumbing Code, International Property Maintenance Code, and International Residential Code.*

102.4.1 Conflicting provisions. Where the extent of the reference to a referenced code or standard includes subject matter that is within the scope of this code or the International Codes as adopted by the authority having jurisdiction listed in Section 102.4, the provisions of this code or the International Codes listed in Section 102.4, as applicable, shall take precedence over the provisions in the referenced code or standard.

102.4.2 Application of referenced standards. The standards referenced in this code and listed in Chapter 11 shall be considered to be part of the requirements of this code to the prescribed extent of such reference. Where differences exist between the provisions of this code and a referenced standard, the provisions of this code shall apply.

102.5 Partial invalidity. In the event that any part or provision of this code is held to be illegal or void, this shall not have the effect of making void or illegal any of the other parts or provisions.

102.6 Existing structures. The legal occupancy of any structure existing on the date of adoption of this code shall be permitted to continue without change, except as is specifically covered in this code, and where adopted by the authority having jurisdiction, the *International Building Code, the International Existing Building Code, the International Property Maintenance Code* or the *International Fire Code*, or as is deemed necessary by the authority having jurisdiction for the general safety and welfare of building occupants and the public.

102.7 Mixed occupancy buildings. In mixed occupancy buildings, each portion of a building shall comply with the specific requirements of this code applicable to each specific occupancy.

PART 2— ADMINISTRATION AND ENFORCEMENT

SECTION 103 DUTIES AND POWERS OF THE AUTHORITY HAVING JURISDICTION

103.1 General. The authority having jurisdiction is hereby authorized and directed to enforce the provisions of this code. The authority having jurisdiction shall have the authority to render interpretations of this code and to adopt policies and procedures in order to clarify the application of its provisions and how this code relates to other applicable codes and ordinances. Such interpretations, policies and procedures shall be in compliance with the intent and purpose of this code and other applicable codes and ordinances. Such policies and procedures shall not have the effect of waiving requirements specifically provided for in this code or other applicable codes and ordinances.

103.2 Applications and permits. The authority having jurisdiction shall enforce compliance with the provisions of this code as part of the enforcement of other applicable codes and regulations, including the referenced codes listed in Section 102.4.

103.3 Notices and orders. The authority having jurisdiction shall issue all necessary notices or orders to ensure compliance with this code.

103.4 Inspections. The authority having jurisdiction shall make inspections, as required, to determine code compliance, or the authority having jurisdiction shall have the authority to accept reports of inspection by approved agencies or individuals. The authority having jurisdiction is authorized to engage such expert opinion as deemed necessary to report on unusual technical issues that arise, subject to the approval of the appointing authority.

SECTION 104 CONSTRUCTION DOCUMENTS

104.1 Information on construction documents. Where adopted by the authority having jurisdiction, the content and format of construction documents shall comply with the *International Building Code*.

SECTION 105 APPROVAL

105.1 General. This code is not intended to prevent the use of any material, method of construction, design, system, or innovative approach not specifically prescribed herein, provided that such construction, design, system or innovative approach has been approved by the authority having jurisdiction as meeting the intent of this code and all other applicable laws, codes and ordinances.

105.2 Approved materials and equipment. Materials, equipment, devices and innovative approaches *approved* by the authority having jurisdiction shall be constructed, installed and maintained in accordance with such approval.

105.2.1 Used materials, products and equipment. Used materials, products and equipment that are to be reused shall meet the requirements of this code for new materials. Used equipment and devices that are to be reused are subject to the approval of the authority having jurisdiction.

105.3 Modifications. Where there are practical difficulties involved in carrying out the provisions of this code, the authority having jurisdiction shall have the authority to grant modifications for individual cases, upon application of the owner or the owner's authorized agent, provided the authority having jurisdiction shall first find that special individual reason makes the strict letter of this code impractical and that the modification is in compliance with the intent and purpose of this code and that such modification does not lessen the minimum requirements of this code. The details of granting modifications shall be recorded and entered in the files of the department.

105.4 Innovative approaches and alternative materials, design, and methods of construction and equipment. The provisions of this code are not intended to prevent the installation of any material or to prohibit any design, innovative approach, or method of construction not specifically prescribed by this code, provided that any such alternative has been *approved*. An alternative material, design, innovative approach or method of construction shall be reviewed and *approved* where the authority having jurisdiction finds that the proposed design is satisfactory and complies with the intent of the provisions of this code, and that the material, design, method or work offered is, for the purpose intended, at least the equivalent of that prescribed in this code. The details of granting the use of alternative materials, designs, innovative approach and methods of construction shall be recorded and entered in the files of the department. Where the alternative material, design or method of construction is not approved, the building official shall respond in writing, stating the reasons the alternative was not approved.

105.4.1 Research reports. Supporting data, where necessary to assist in the approval of materials or assemblies not specifically provided for in this code, shall consist of valid research reports from *approved* sources.

105.4.2 Tests. Where there is insufficient evidence of compliance with the provisions of this code, or evidence that a material or method does not conform to the requirements of this code, or in order to substantiate claims for alternative materials or methods, the authority having jurisdiction shall have the authority to require tests as evidence of compliance to be made at no expense to the jurisdiction. Test methods shall be as specified in this code or by other recognized test standards. In the absence of recognized and accepted test methods, the authority having jurisdiction shall approve the testing procedures. Tests shall be performed by an approved agency. Reports of such tests shall be retained by the authority having jurisdiction

for the period required for retention of public records.

105.5 Compliance materials. The authority having jurisdiction shall be permitted to approve specific computer software, worksheets, compliance manuals and other similar materials that meet the intent of this code.

105.6 Approved programs. The authority having jurisdiction shall have the authority to deem a national, state or local program as meeting or exceeding this code. Buildings *approved* in writing by such a program shall be considered to be in compliance with this code.

105.6.1 Specific approval. The authority having jurisdiction shall have the authority to approve programs or compliance tools for a specified application, limited scope or specific locale, including approval that is applicable to a specific section or chapter of this code.

SECTION 106 PERMITS

106.1 Required. Any owner or owner's authorized agent who intends to construct, enlarge, alter, repair, move, demolish, or change the occupancy of a building or structure, or to erect, install, enlarge, alter, repair, remove, convert or replace any energy, electrical, gas, mechanical or plumbing system, the installation of which is regulated by this code, or to cause any such work to be done, shall first make application to the authority having jurisdiction and obtain the required permit under the applicable adopted code (*Informative Note:* e.g., *International Building Code*) or regulation relevant to the intended work. Separate permits shall not be issued under this code. Exemptions from permit requirements shall not be deemed to grant authorization for any work to be done in any manner in violation of the provisions of this code or any other applicable laws, codes or ordinances of this jurisdiction.

SECTION 107 INSPECTIONS

107.1 General. Construction or work for which a permit is required shall be subject to inspection by the authority having jurisdiction and such construction or work shall remain visible and able to be accessed for inspection purposes until approved. Approval as a result of an inspection shall not be construed to be an approval of a violation of the provisions of this code or of other ordinances of the jurisdiction. Inspections presuming to give authority to violate or cancel the provisions of this code or of other ordinances of the jurisdiction shall not be valid. It shall be the duty of the owner or the owner's authorized agent to cause the work to remain accessible and exposed for inspection purposes. Neither the authority having jurisdiction nor the jurisdiction shall be liable for the expense entailed in the removal or replacement of any material required to allow inspection.

SCOPE AND ADMINISTRATION

SECTION 108 BOARD OF APPEALS

108.1 General. Appeals of orders, decisions or determinations made by the authority having jurisdiction relative to the application and interpretation of this code shall be made to a Board of Appeals as determined by the jurisdiction.

108.2 Limitations on authority. An application for appeal shall be based on a claim that the true intent of this code or the rules legally adopted there under have been incorrectly interpreted, the provisions of this code do not fully apply or an equivalent or better form of construction is proposed. The board shall not have authority to waive requirements of this code.

108.3 Qualifications. The members of the board of appeals related to interpretation of this code shall be qualified by experience and training in the matters covered by this code and shall not be employees of the jurisdiction.

SECTION 109 CERTIFICATE OF OCCUPANCY

109.1 Violations. Issuance of a certificate of occupancy shall not be construed as an approval of a violation of the provisions of this code or of other ordinances of the jurisdiction.

CHAPTER 2
RESERVED

CHAPTER 3

DEFINITIONS, ABBREVIATIONS AND ACRONYMS

301.1 (3.1) General. Certain terms, abbreviations, and acronyms are defined in this chapter for the purposes of this code. These definitions are applicable to all chapters of this code.

Terms that are not defined herein, but that are defined in standards that are referenced herein (**Informative Note:** e.g., ANSI/ASHRAE/IES Standard 90.1), shall have the meanings as defined in those standards.

Other terms that are not defined shall have their ordinarily accepted meanings within the context in which they are used. Ordinarily accepted meanings shall be based on American standard English language usage, as documented in an unabridged dictionary accepted by the *authority having jurisdiction*.

301.2 (3.2) Definitions.

agricultural land: land that is, or was, within ten years prior to the date of the building permit application for the *building project*, primarily devoted to the commercial production of horticultural, viticultural, floricultural, dairy, apiary, vegetable, or animal products or of berries, grain, hay, straw, turf, seed, finfish in upland hatcheries, or livestock, and that has long-term commercial significance for agricultural production. Land that meets this definition is *agricultural land* regardless of how the land is zoned by the local government with zoning jurisdiction over that land.

air, makeup: see ANSI/ASHRAE Standard 62.1.

air, outdoor: see ANSI/ASHRAE Standard 62.1.

air, transfer: see ANSI/ASHRAE Standard 62.1.

airflow, minimum outdoor: the outdoor airflow provided by a ventilation system to meet requirements for indoor air quality, excluding any additional *outdoor air* intake to reduce or eliminate the need for *mechanical cooling*.

alternative daily cover: cover material, other than earthen material, placed on the surface of the active face of a municipal solid-waste landfill at the end of each operating day to control vectors, fires, odors, blowing litter, and scavenging.

annual sunlight exposure (ASE): the percent of an analysis area that exceeds a specified direct-sunlight illuminance level for more than a specified number of hours per year (Source: IES LM 83). *Annual sunlight exposure* is a metric that quantifies the potential for excessive sunlight in interior work environments.

attic and other roofs: see ANSI/ASHRAE/IES Standard 90.1.

authority having jurisdiction (AHJ): the agency or agent responsible for enforcing this code.

automatic: see ANSI/ASHRAE/IES Standard 90.1.

baseline building design: see ANSI/ASHRAE/IES Standard 90.1.

baseline building performance: see ANSI/ASHRAE/IES Standard 90.1.

Basis of Design (BoD): a document that records the concepts, calculations, decisions, and product selections used to meet the *owner's project requirements* and to satisfy applicable regulatory requirements, standards, and guidelines. The document includes both narrative descriptions and lists of individual items that support the design process. (See *owner's project requirements*.)

bilevel lighting control: lighting control in a *space* that provides at least one intermediate level of lighting power in addition to fully ON and fully OFF. Continuous dimming systems are covered by this definition.

biobased product: a commercial or industrial product (other than food or feed) that comprises, in whole or in significant part, biological products or renewable agricultural materials (including *plant*, animal, and marine materials) or forestry materials.

biodiverse plantings: nonhomogeneous, multiple-species plantings.

breathing zone: see ANSI/ASHRAE Standard 62.1.

brownfield: a *site* documented as contaminated by means of an ASTM E1903 Phase II Environmental Site Assessment or a *site* classified as a *brownfield* by a local, state, or federal government agency.

building entrance: see ANSI/ASHRAE/IES Standard 90.1.

building envelope: see ANSI/ASHRAE/IES Standard 90.1.

building project: a building, or group of buildings, and *site* that utilize a single submittal for a construction permit or that are within the boundary of contiguous properties under single ownership or effective control. (See *owner*.)

carbon dioxide equivalent (CO₂e): a measure used to compare the impact of various greenhouse gases based on their global warming potential (GWP). *CO₂e* approximates the time-integrated warming effect of a unit mass of a given greenhouse gas relative to that of carbon dioxide (CO₂). GWP is an index for estimating the relative global warming contribution of atmospheric emissions of 1 kg of a particular greenhouse gas compared to emissions of 1 kg of CO₂. The following GWP values are used based on a 100-year time horizon: 1 for CO₂, 25 for methane (CH₄), and 298 for nitrous oxide (N₂O).

classroom: a *space* primarily used for scheduled instructional activities.

climate zone: see Normative Appendix A.

combined energy efficiency ratio (CEER [I-P]) (CCOP_c [SI]): the combined energy efficiency is a ratio of the total cooling in one year divided by the total energy from active, stand-by, and OFF modes as defined in AHAM Standard RAC-1; Btu/h/W (W/W).

DEFINITIONS, ABBREVIATIONS AND ACRONYMS

verification: the process by which specific documents, components, equipment, assemblies, systems, and interfaces among systems are confirmed to comply with the criteria described in the *owner's project requirements*. (See *owner's project requirements*.)

vertical fenestration: see ANSI/ASHRAE/IES Standard 90.1.

view fenestration: *fenestration* that complies with all of the following:

- a. It provides building occupants with a view to the outdoors or to an interior daylight atrium.
- b. It has undiffused glazing with a haze value less than 3%, as determined in accordance with ASTM D1003.
- c. It has a center-of-glass visible transmittance (VT) of not less than 20%.
- d. The product of the center-of-glass VT and the openness factor of screens, patterned films, and ceramic frits is not less than 20%.
- e. Where *dynamic glazing* is provided, such glazing has a center-of-glass VT of not less than 20% at the highest end of its range.
- f. Where nonoperable opaque window treatments are provided, such as blinds, shades, and louvers, such treatments do not obstruct more than 40% of the *fenestration* glazing area.

wall: see ANSI/ASHRAE/IES Standard 90.1.

wall area, gross: see ANSI/ASHRAE/IES Standard 90.1.

water, alternate on-site sources of: *alternate on-site sources of water* include, but are not limited to:

- a. rainwater or stormwater harvesting,
- b. air conditioner condensate,
- c. grey water from interior applications and treated as required,
- d. swimming-pool filter backwash water,
- e. cooling-tower blowdown water,
- f. foundation drain water,
- g. industrial process water, and
- h. on-site wastewater treatment *plant* effluent.

water, nonpotable: water that is not *potable water*. (See *water, potable*.)

water, potable: water from public drinking water systems or from natural freshwater sources, such as lakes, streams, and aquifers, where water from such natural sources would or could meet drinking water standards.

water, reclaimed: *nonpotable water* derived from the treatment of waste water by a facility or system licensed or permitted to produce water meeting the jurisdiction's water requirements for its intended uses, including, but not limited to, above-surface landscape irrigation.

water-bottle filling station: a plumbing fixture or fixture fitting that is controlled by the user for the sole intended purpose of dispensing *potable water* into a personal drinking

water bottle. Such fixtures and fittings are connected to the *potable water* distribution system of the premises and can be stand-alone fixtures or integrated with another fixture.

water factor (WF):

- a. **clothes washer (residential and commercial):** the quantity of water in gallons (litres) used to wash each cubic foot (cubic metre) of machine capacity.
- b. **residential dishwasher:** the quantity of water use in gallons (litres) per full machine wash and rinse cycle.

weatherproofing system: a group of components, including associated adhesives and primers, that when installed create a protective envelope against water and wind.

wetlands: those areas that are inundated or saturated by surface or groundwater at a frequency and duration sufficient to support, and that under normal circumstances do support, a prevalence of vegetation adapted for life in saturated soil conditions. This definition incorporates all areas that would meet the definition of "wetlands" under applicable federal or state guidance—regardless of whether they are officially designated, delineated, or mapped—including man-made areas that are designed, constructed, or restored to include the ecological functions of natural *wetlands*.

301.3 (3.3) Abbreviations and Acronyms

µg	microgram
AC	alternating current
AHJ	authority having jurisdiction
AHRI	Air-Conditioning, Heating, and Refrigeration Institute
ANSI	American National Standards Institute
ASE	annual sunlight exposure
ASME	American Society of Mechanical Engineers
ASTM	American Society for Testing and Materials International
BIFMA	The Business and Institutional Furniture Manufacturer's Association
BMS	building management system
BoD	Basis of Design
BPF	building performance factor
Btu	British thermal unit
Btu/h	British thermal unit per hour
BUG	backlight, uplight, and glare
CAC	ceiling attenuation class
CCOP	combined coefficient of performance
CDPH	California Department of Public Health
CEER	combined energy efficiency ratio
CFC	Chlorofluorocarbon
cfm	cubic feet per minute (ft ³ /min)
CH ₄	methane
c.i.	continuous insulation

CHAPTER 4
RESERVED

CHAPTER 5

SITE SUSTAINABILITY

501.1 (5.1) Scope. This section addresses requirements for *building projects* that pertain to *site* selection, *site* development, mitigation of *heat island effect*, light pollution reduction, and mitigation of transportation impacts.

501.2 (5.2) Compliance. All of the provisions of Chapter 5 (Section 5) are mandatory provisions.

501.3 (5.3) Mandatory Provisions.

501.3.1 (5.3.1) Site Selection. The *building project* shall comply with Sections 501.3.1.1 (5.3.1.1) and 501.3.1.2 (5.3.1.2).

501.3.1.1 (5.3.1.1) Allowable Sites. The *building project* shall take place in or on one of the following:

- a. An existing *building envelope*.
- b. A *brownfield*.
- c. A *greyfield*.
- d. A *greenfield* that is within 1/2 mi (800 m) of *residential* land that is developed, or that has one or more buildings under construction, with an average density of ten *dwelling units* per acre (4 units per ha) unless that *site* is *agricultural land* or *forest land*. Proximity is determined by drawing a circle with a 1/2 mi (800 m) radius around the center of the proposed *site*.
- e. A *greenfield* where the proposed building complies with ASTM E2843, unless that *site* is *agricultural land* or *forest land*.
- f. A *greenfield* where the proposed building complies with ASTM E2844, unless that *site* is *agricultural land* or *forest land*.
- g. A *greenfield* that is *agricultural land*, and the purpose of the proposed building is related to the agricultural use of the land.
- h. A *greenfield* that is *forest land*, and the purpose of the proposed building is related to the forestry use of the land.
- i. A *greenfield* that is *designated park land*, and the purpose of the proposed building is related to the use of the land as a park.

501.3.1.2 (5.3.1.2) Prohibited Development Activity. There shall be no *site* disturbance or development of the following:

- a. Previously undeveloped land having an elevation lower than 5 ft (1.5 m) above the elevation of the 100-year flood, as defined by USFEMA.

Exceptions:

1. Development of *low-impact trails* shall be allowed anywhere within a flood zone.

2. Development of building structures shall be allowed in alluvial “AO” designated flood zones, provided that such structures include engineered flood-proofing up to an elevation that is at least as high as the minimum lowest floor elevation determined by the *authority having jurisdiction (AHJ)* and provided that the *site* includes drainage paths constructed to guide floodwaters around and away from the structures.

- b. Land within 150 ft (50 m) of any *fish and wildlife habitat conservation area*.

Exceptions:

1. Development of *low-impact trails* shall be allowed, provided that such trails are located at least 15 ft (4.5 m) from the area.
2. *Site* disturbance or development shall be allowed for habitat enhancement measures.

- c. Land within 100 ft (35 m) of any *wetland*

Exceptions:

1. Development of *low-impact trails* shall be allowed, provided that such trails are located at least 15 ft (4.5 m) from the *wetland*.
2. *Site* disturbance or development shall be allowed for habitat enhancement measures or for restoration of the functions of the *wetland*.

501.3.2 (5.3.2) Predesign Site Inventory and Assessment. A predesign inventory and assessment of the natural resources of the *building project site* shall be submitted with the *site* design and *construction documents*. The inventory and assessment shall include all of the following:

- a. Location of any prohibited development areas identified in Section 501.3.1.2 (5.3.1.2) that are located on or adjacent to the *building project site*.
- b. Identification of *invasive plant* species on the *site*.
- c. Identification of *native plant* species on the *site*.
- d. Identification of *site* features designated for preservation.

501.3.3 (5.3.3) Plants.

501.3.3.1 (5.3.3.1) Invasive Plants. *Invasive plants* shall be removed from the *building project site* and destroyed or disposed of in a land fill. *Invasive plants* shall not be planted on the *building project site*.

4. Lighting for theatrical purposes, including performance, stage, film production, and video production.
5. Lighting for athletic playing areas.
6. Lighting that is in use for no more than 60 continuous days and is not reinstalled any sooner than 60 days after being uninstalled.
7. Lighting for industrial production, material handling, transportation *sites*, and associated storage areas.
8. Theme elements in theme/amusement parks.
9. Roadway lighting required by governmental authorities.
10. Lighting classified for and used in hazardous locations as specified in NFPA 70.
11. Lighting for swimming pools and water features.
12. Lighting in *LZ3* and *LZ4*, solely for uplighting structures, building façades, or landscaping.
13. Lighting in *LZ1* and *LZ2*, solely for uplighting structures, building façades, or landscaping, provided the applicable lighting power densities (LPDs) do not exceed 50% of the *lighting power allowances* in ANSI/ASHRAE/IES Standard 90.1, Table 9.4.2-2.

**TABLE 501.3.6.2A (TABLE 5.3.6.2A)
MAXIMUM ALLOWABLE GLARE RATINGS FOR BUILDING-MOUNTED
LUMINAIRES WITHIN TWO MOUNTING HEIGHTS OF ANY PROPERTY LINE^{a,b}**

DISTANCE IN MOUNTING HEIGHTS TO NEAREST PROPERTY LINE	LZ0	LZ1	LZ2	LZ3	LZ4
≥ 1 and < 2	G0	G0	G1	G1	G2
≥ 0.5 and < 1	G0	G0	G0	G1	G1
< 0.5	G0	G0	G0	G0	G1

a. For property lines that abut public walkways, bikeways, plazas, and parking lots, the property line may be considered to be 5 ft (1.5 m) beyond the actual property line for the purpose of determining compliance with this section. For property lines that abut public roadways and public transit corridors, the property line may be considered to be the centerline of the public roadway or public transit corridor for the purpose of determining compliance with this section.

b. Backlight, uplight, and glare ratings are defined based on specific lumen limits per IES TM-15 Addendum A.

**TABLE 501.3.6.2B (TABLE 5.3.6.2B)
MAXIMUM ALLOWABLE BACKLIGHT, UPLIGHT, AND GLARE (BUG) RATINGS^{a,b,c,d}**

	LZ0	LZ1	LZ2	LZ3	LZ4
Allowed Backlight Rating					
> 2 mounting heights from property line	B1	B3	B4	B5	B5
1 to 2 mounting heights from property line	B1	B2	B3	B4	B4
0.5 to 1 mounting height to property line	B0	B1	B2	B3	B3
< 0.5 mounting height to property line	B0	B0	B0	B1	B2
Allowed Uplight Rating	U0	U1	U2	U3	U4
Allowed Glare Rating	G0	G1	G2	G3	G4

a. Except where installed on a building surface, luminaires that are located at a distance of two times the mounting height of the luminaire or less from a property line shall have the backlight of the luminaire aimed toward and perpendicular to the nearest property line. Backlight is that part of the luminaire’s lumen output that was used to determine the backlight rating in its final angular position.

b. For property lines that abut public walkways, bikeways, plazas, and parking lots, the property line may be considered to be 5 ft (1.5 m) beyond the actual property line for the purpose of determining compliance with this section. For property lines that abut public roadways and public transit corridors, the property line may be considered to be the centerline of the public roadway or public transit corridor for the purpose of determining compliance with this section.

c. If the luminaire is installed in other than the intended manner, or is an adjustable luminaire for which the aiming is specified, the rating shall be determined by the actual photometric geometry in the aimed orientation.

d. Backlight, uplight, and glare ratings are defined based on specific lumen limits per IES TM-15 Addendum A.

**TABLE 501.3.6.3 (TABLE 5.3.6.3)
MAXIMUM ALLOWABLE PERCENTAGE OF UPLIGHT**

	LZ0	LZ1	LZ2	LZ3	LZ4
Percentage of total exterior fixture lumens allowed to be emitted above 90 degrees or higher from nadir (straight down)	0%	0%	1%	2%	5%

be sized to supply the future charging stations based on a design load of not less than 40 amp per required parking *space* at a supply voltage of not less than 208/240 VAC.

**TABLE 501.3.7.3 (TABLE 5.3.7.3)
NUMBER OF SPACES REQUIRED TO HAVE RACEWAYS**

TOTAL NUMBER OF PARKING SPACES PROVIDED	NUMBER OF SPACES REQUIRED TO HAVE RACEWAY
1 through 25	1
26 through 50	2
51 through 75	4
76 through 100	5
101 through 150	7
151 through 200	10
201 and over	5% of total

501.3.8 (5.3.8) Building Site Waste Management.

501.3.8.1 (5.3.8.1) Building Site Waste Management Plan. A building *site* waste management plan shall be developed and implemented for excavated soil, rock, and land-clearing debris. Land-clearing debris is limited to stumps and vegetation. Diverted land-clearing debris and removed rock and soil shall not be sent to *sites* where development activity is prohibited by Section 501.3.1.2 (5.3.1.2) or to *greenfields* other than those being used for agricultural purposes or being developed as part of a *building project*.

Not less than 90% of the land-clearing debris, excluding *invasive plant* materials, shall be diverted from disposal in landfills and incinerators other than waste-to-energy systems with an energy-recovery efficiency rate higher than 60%. Land-clearing debris calculations shall be based on either weight or volume but not both. Receipts or other documentation related to diversion shall be maintained through the course of construction.

The plan shall address all of the following:

- a. Land-clearing debris, rock, and soil to be diverted from disposal by composting, recycling, or reuse.
- b. Waste materials that will be diverted on-site.
- c. The locations to which waste materials will be diverted off-site.
- d. Soils to be stockpiled for future use at any location.
- e. Woody waste to be used as fuel.
- f. The destruction and disposal of *invasive plant* materials.
- g. The methods of removal of any contaminated soils.
- h. The treatment of vegetation to comply with the rules of government-designated quarantine zones for invasive insect species.

CHAPTER 6

WATER USE EFFICIENCY

601.1 (6.1) Scope. This section specifies requirements for *potable water* and *nonpotable water* use efficiency, both for the *site* and for the building, and water monitoring.

601.2 (6.2) Compliance. All provisions of Section 6 are mandatory provisions.

601.3 (6.3) Mandatory Provisions.

601.3.1 (6.3.1) Site Water Use Reduction.

601.3.1.1 (6.3.1.1) Landscape Design. A minimum of 60% of the area of the *improved landscape* shall be in *biodiverse planting* of *native plants* and *rainfall-ET_c compatible plants*.

Exceptions:

1. The area of dedicated athletic fields, golf courses, driving ranges, and areas dedicated for production of food for human consumption, shall be excluded from the calculation of the *improved landscape* for schools, *residential* common areas, or public recreational facilities.
2. Landscape areas irrigated solely with *alternate on-site sources of water* shall be exempt from these requirements.
3. Where average annual rainfall is less than 12 in. (300 mm), *plants* other than *turfgrass*, with an annual *ET_c* of 15 in. (380 mm) or less, shall be deemed equivalent to *rainfall-ET_c compatible plants*.

601.3.1.2 (6.3.1.2) Irrigation. For golf courses and driving ranges, only municipally reclaimed water or *alternate on-site sources of water* shall be used to irrigate the landscape. For other landscaped areas, not greater than one-third of *improved landscape* area is allowed to be irrigated with *potable water*. The area of dedicated athletic fields shall be excluded from the calculation of the *improved landscape* for schools, *residential* common areas, and public recreational facilities. All other irrigation shall be provided from *alternate on-site sources of water* or municipally reclaimed water.

Exception: *Potable water* is allowed to be temporarily used on such newly installed landscape for the *landscape establishment period*. The amount of *potable water* allowed to be applied to the newly planted areas during the temporary *landscape establishment period* shall not exceed 70% of *ET_o* for *turfgrass* and 55% of *ET_o* for other plantings. Where municipally reclaimed water is available at a water main within 200 ft (60 m) of the project *site*, such water shall be used instead of *potable water* during the *landscape establishment period*. After the *landscape establishment period* has expired, all irriga-

tion water use shall comply with the requirements established elsewhere in this code.

601.3.1.2.1 (6.3.1.2.1) Irrigation System Design. The design of the irrigation system shall be performed by an accredited or certified irrigation professional and shall be in accordance with the following:

a. Irrigation systems:

1. Shall be based on *hydrozones*. *Turfgrass* areas shall be on their own *irrigation stations*.
2. Shall have backflow prevention in accordance with the plumbing code (**Informative note:** e.g., *International Plumbing Code*).
3. Shall have a master valve on municipally supplied water sources that allows pressurization of the irrigation mainline only when irrigation is scheduled.
4. Shall have a flow sensor and monitoring equipment that will shut off the control valve if the flow exceeds normal flow from an *irrigation station*.
5. Shall prevent piping from draining between irrigation events.

b. Irrigation emission devices shall comply with ASABE/ICC 802, *Landscape Irrigation Sprinkler and Emitter Standard*.

c. Irrigation sprinklers:

1. Shall not spray water directly on buildings or *hardscape* area.
2. Shall have matched precipitation rate nozzles within an *irrigation station*.
3. Shall be prohibited on landscape areas having any dimension less than 4 ft (1220 mm).
4. Shall have an application rate less than or equal to 0.75 in. (19 mm) per hour on slopes greater than 1 unit vertical in 4 units horizontal.
5. Shall be limited to use with *turfgrass* or *ground cover* areas with vegetation maintained at 8 in. (203 mm) or less in height.
6. Where of the pop-up configuration, shall have a pop-up height of not less than 4 in (100 mm).

**TABLE 601.3.2.1 (TABLE 6.3.2.1)
PLUMBING FIXTURES AND FITTINGS REQUIREMENTS**

PLUMBING FIXTURE	MAXIMUM
Water closets (toilets)—flushometer single-flush valve type	Single-flush volume of 1.28 gal (4.8 L)
Water closets (toilets)—flushometer dual-flush valve type	Full-flush volume of 1.28 gal (4.8 L)
Water closets (toilets)—single-flush tank-type	Single-flush volume of 1.28 gal (4.8 L)
Water closets (toilets)—dual-flush tank-type	Full-flush volume of 1.28 gal (4.8 L)
Urinals	Flush volume 0.5 gal (1.9 L)
Public lavatory faucets	Flow rate—0.5 gpm (1.9 L/min)
Public metering self-closing faucet	0.25 gal (1.0 L) per metering cycle
Residential bathroom lavatory sink faucets	Flow rate—1.5 gpm (5.7 L/min)
Residential kitchen faucets	Flow rate—1.8 gpm (6.8 L/min) ^a
Residential showerheads	Flow rate—2.0 gpm (7.6 L/min)
Residential shower compartment (stall) in <i>dwelling units</i> and guest rooms	Flow rate from all shower outlets total of 2.0 gpm (7.6 L/min)

a. With provision for a temporary override to 2.2 gpm (8.3 L/min) as specified in Section 601.3.2(g) [6.3.2.1(g)].

d. Microirrigation zones:

1. Shall be equipped with pressure regulators, filters, and flush assemblies.
2. Shall have indicators that allow confirmation of operation by visual inspection.

601.3.1.2.2 (6.3.1.2.2) Controls. Where any irrigation system for the project *site* uses an *automatic* controller, the system shall be controlled by a qualifying *smart controller* that uses *evapotranspiration (ET)* and weather data to adjust irrigation schedules and that complies with the minimum requirements. Alternatively, the system shall be controlled by an on-site rain or moisture sensor that automatically shuts off the system after a predetermined amount of rainfall or sensed moisture in the soil. Qualifying *smart controllers* shall be labeled according to USEPA WaterSense Specification for Weather-Based Irrigation Controllers or tested in accordance with Irrigation Association SWAT Climatologically Based Controllers, 8th Testing Protocol. *Smart controllers* that use *ET* data shall provide the following irrigation amounts:

- a. *Irrigation adequacy*—80% minimum ET_c .
- b. *Irrigation excess*—not to exceed 10% of ET_c .

Exception: A temporary irrigation system used exclusively for the establishment of new landscape shall be exempt from this requirement. Temporary irrigation systems shall be removed or permanently disabled at such time as the *landscape establishment period* has expired.

601.3.1.2.2.1 (6.3.1.2.2.1). The following settings and schedule for the irrigation control system shall be posted on or adjacent to the controller:

- a. Precipitation rate of each *irrigation station*.
- b. *Plant* factors for each *hydrozone*.
- c. Soil type.
- d. Rain sensor settings.
- e. Soil moisture sensor settings, where installed.
- f. Peak demand schedule, including run times, cycle starts, and soak times.
- g. Maximum runtimes to prevent water runoff.

601.3.1.2.3 (6.3.1.2.3) Irrigation of Rainfall- ET_c Compatible Plants. The use of *potable water* or *reclaimed water* for irrigation of *adapted plants* is prohibited after the *landscape establishment period*. In-ground irrigation systems for *rainfall- ET_c compatible plants* using potable or off-site treated *reclaimed water* are prohibited. After the *landscape establishment period* of *adapted plants*, the irrigation system using *potable water* or *reclaimed water* shall be permanently disabled or removed from *site*.

Exception: *Plants* deemed equivalent to *rainfall- ET_c compatible plants* by Section 601.3.1.1 (6.3.1.1), Exception 3, shall be exempt from the requirements of Section 601.3.1.3 (6.3.1.3).

601.3.2 (6.3.2) Building Water Use Reduction.

601.3.2.1 (6.3.2.1) Plumbing Fixtures and Fittings. Plumbing fixtures (water closets and urinals) and fit-

**TABLE 601.3.4.1A (TABLE 6.3.4.1A)
WATER SUPPLY SOURCE MEASUREMENT THRESHOLDS**

WATER SOURCE	MAIN MEASUREMENT THRESHOLD
Potable water	1000 gal/day (3800 L/day)
Municipally <i>reclaimed water</i>	1000 gal/day (3800 L/day)
Alternate sources of water	500 gal/day (1900 L/day)

**TABLE 601.3.4.1B (TABLE 6.3.4.1B)
SUBSYSTEM WATER MEASUREMENT THRESHOLDS**

SUBSYSTEM	SUBMETERING THRESHOLD
Cooling towers (meter on makeup water and blowdown)	Cooling tower flow through tower > 500 gpm (30 L/s)
Evaporative coolers	Makeup water > 0.6 gpm (0.04 L/s)
Steam and hot-water boilers	> 500,000 Btu/h (150 kW) input
Total irrigated landscape area with controllers	> 25,000 ft ² (2500 m ²)
Separate campus or project buildings	Consumption > 1000 gal/day (3800 L/day)
Separately leased or rental <i>space</i>	Consumption > 1000 gal/day (3800 L/day)
Any large water-using process	Consumption > 1000 gal/day (3800 L/day)

601.3.5.1 (6.3.5.1) Demand-Initiated Regeneration. Water softeners shall be equipped with demand-initiated regeneration control systems. Timer-based control systems shall be prohibited.

601.3.5.2 (6.3.5.2) Water Consumption. During regeneration, water softeners shall have a maximum water consumption of 4 gal (15.1 L) per 1000 grains (17.1 g/L) of hardness removed, as measured in accordance with NSF 44.

601.3.5.3 (6.3.5.3) Waste Connections. Waste water from water softener regeneration shall not discharge to reclaimed water collection systems and shall discharge in accordance with the *International Plumbing Code*.

601.3.5.4 (6.3.5.4) Efficiency and Listing. Water softeners that regenerate in place, that are connected to the water system they serve by piping not exceeding 1¹/₄ in. (31.8 mm) in diameter, or that have a volume of 3 ft³ (0.085 m³) or more of cation exchange media shall have a rated salt efficiency of not less than 4000 grains of total hardness exchange per pound of salt (571 grams of total hardness exchange per kilogram of salt), based on sodium chloride equivalency, and shall be listed and labeled in accordance with NSF 44. All other water softeners shall have a rated salt efficiency of not less than 3500 grains of total hardness exchange per pound of salt (500 grams of total hardness exchange per kilogram of salt), based on sodium chloride equivalency.

601.3.6 (6.3.6) Reverse Osmosis Water Treatment Systems. Reverse osmosis systems shall be equipped with an *automatic* shutoff valve that prevents the production of reject water when there is no demand for treated water. Point-of-use reverse osmosis treatment systems for drinking water shall be listed and labeled in accordance with NSF 58.

601.3.7 (6.3.7) On-Site Reclaimed Water Treatment Systems. On-site reclaimed water treatment systems, including grey water reuse treatment systems and waste water treatment systems, used to produce *nonpotable water* for use in water closet and urinal flushing, surface irrigation, and similar applications shall be listed and labeled in accordance with NSF 350.

601.3.8 (6.3.8) Dual Water Supply Plumbing.

601.3.8.1 (6.3.8.1) Where sufficient supply of *reclaimed water* or *alternate on-site sources of water* is available, or planned to be available, within five years of completed building construction, the water supply system within the building shall be installed to allow the supply of reclaimed or alternative water to all urinals and water closets.

Exceptions:

- Existing buildings under renovation, where the water supply to the urinals and water closets within the building is to remain intact, shall not be required to supply *nonpotable water* to urinals and water closets.
- Urinals and water closets designed to operate without the use of water shall not be required to have alternate or reclaimed water supply to the fixture.

CHAPTER 7

ENERGY EFFICIENCY

701.1 (7.1) Scope. This section specifies requirements for energy efficiency for buildings and appliances, for *on-site renewable energy systems*, and for energy measuring.

701.2 (7.2) Compliance. The energy systems shall comply with Section 701.3 (7.3), “Mandatory Provisions,” and either

- a. Section 701.4 (7.4), “Prescriptive Option,” or
- b. Section 701.5 (7.5), “Performance Option.”

701.3 (7.3) Mandatory Provisions.

701.3.1 (7.3.1) General. *Building projects* shall be designed to comply with Sections 5.4, 6.4, 7.4, 8.4, 9.4, and 10.4 of ANSI/ASHRAE/IES Standard 90.1.

701.3.1.1 (7.3.1.1) Continuous Air Barrier. The exceptions to the requirement for a *continuous air barrier* in ANSI/ASHRAE/IES Standard 90.1, Section 5.4.3.1, for specific *climate zones* and constructions shall not apply. The testing criteria of Section 1001.3.1.5(a) [10.3.1.3.5(a)] shall supersede ANSI/ASHRAE/IES Standard 90.1, Section 5.4.3.1.3(a).

701.3.2 (7.3.2) On-Site Renewable Energy Systems. *Building project* design shall show allocated *space* and pathways for future installation of *on-site renewable energy systems* and associated infrastructure that provide the annual energy production equivalent of not less than 6.0 kBtu/ft² (20 kWh/m²) for single-story buildings and not less than 10.0 kBtu/ft² (32 kWh/m²) multiplied by the *gross roof area* in feet squared (metres squared) for all other buildings.

Exceptions:

1. *Building projects* that have an annual daily average incident solar radiation available to a flat plate collector oriented due south at an angle from horizontal equal to the latitude of the collector location less than 1.2 kBtu/ft²·day (4.0 kWh/m²·day), accounting for existing buildings, permanent infrastructure that is not part of the *building project*, topography, or trees.
2. *Building projects* that comply with Section 701.4.1.1 (7.4.1.1).

701.3.3 (7.3.3) Energy Consumption Management.

701.3.3.1 (7.3.3.1) Consumption Management. Measurement devices with remote communication capability shall be provided to collect energy consumption data for each energy supply source to the building (including gas, electricity, and district energy) that exceeds the thresholds listed in Table 701.3.3.1A (7.3.3.1A). The measurement devices shall have the capability to automatically communicate the energy consumption data to a data acquisition system.

For all buildings that exceed the threshold in Table 701.3.3.1A (7.3.3.1A), subsystem measurement

devices with remote capability (including current sensors or flowmeters) shall be provided to measure energy consumption data of each subsystem for each use category that exceeds the thresholds listed in Table 701.3.3.1B (7.3.3.1B).

The energy consumption data from the subsystem measurement devices shall be automatically communicated to the data acquisition system.

**TABLE 701.3.3.1A (TABLE 7.3.3.1A)
ENERGY SOURCE THRESHOLDS**

ENERGY SOURCE	THRESHOLD
Electrical service	> 200 kVA
On-site renewable electric power	All systems > 1 kVA (peak)
Gas and district services	> 1,000,000 Btu/h (300 kW)
<i>Geothermal energy</i>	> 1,000,000 Btu/h (300 kW) heating
On-site renewable thermal energy	> 100,000 Btu/h (30 kW)

**TABLE 701.3.3.1B (TABLE 7.3.3.1B)
SYSTEM ENERGY USE THRESHOLDS**

USE (TOTAL OF ALL LOADS)	SUBSYSTEM THRESHOLD
HVAC system	Connected electric load > 100kVA
	Connected gas or district services load > 500,000 Btu/h (150 kW)
People moving	Sum of all feeders > 50 kVA
Lighting	Connected load > 50 kVA
Process and plug process	Connected load > 50 kVA
	Connected gas or district services load > 250,000 Btu/h (75 kW)

701.3.3.2 (7.3.3.2) Energy Consumption Data Collection and Display. All building measurement devices shall be configured to automatically communicate the energy data to the data acquisition system. Measurement devices shall provide daily data and shall record hourly energy profiles. Such hourly energy profiles shall be capable of being used to assess building performance at least monthly. The hourly energy profiles shall be displayed.

701.3.3.3 (7.3.3.3) Data Storage and Retrieval. The data acquisition system shall be capable of electronically storing the data from the measurement devices and other sensing devices for a minimum of 36 months and creating user reports showing hourly, daily, monthly, and annual energy consumption.

Exception: Portions of buildings used as *residential*.

701.3.4 (7.3.4) Automated Demand Response. *Building projects* shall contain *automatic* control systems that have

the capability to reduce building equipment loads to lower electric peak demand of the building.

The building controls shall be designed with automated demand-response (DR) infrastructure capable of receiving DR requests from the utility, electrical system operator, or third-party DR program provider and automatically implementing load adjustments to the HVAC and lighting systems.

701.3.4.1 (7.3.4.1) HVAC Systems Zone Set Points.

The building project's HVAC systems shall be programmed to allow centralized demand reduction in response to a signal from a centralized contact or software point in accordance with the following:

- a. The controls shall be programmed to automatically adjust upward the zone operating cooling set points by a minimum of 3°F (1.7°C).
- b. The controls shall be programmed to automatically adjust downward the zone operating heating set points by a minimum of 3°F (1.7°C).
- c. The controls shall be programmed to automatically adjust downward the zone operating cooling set points by a minimum of 2°F (1.1°C).
- d. The automated DR strategy shall include both ramp-up and ramp-down logic to prevent the building peak demand from exceeding that expected without the DR implementation.

Exception: Systems serving areas deemed by the *owner* to be critical in nature.

701.3.4.2 (7.3.4.2) Variable-Speed Equipment. For HVAC equipment with variable-speed control, the controls shall be programmed to allow *automatic* adjustment of the maximum speed of the equipment to 90% of design speed during automated DR events. Airflow adjustments shall not decrease the supply airflow rate below the level that would result in outdoor airflow being below the *minimum outdoor airflow rates* specified in Section 801.3.1.1 (8.3.1.1), or that would cause adverse building pressurization problems.

701.3.4.3 (7.3.4.3) Lighting. For *building projects* with interior lighting control systems controlled at a central point, such systems shall be programmed to allow automated DR. The programming shall reduce the total connected lighting power demand during a DR event by not less than 15% but no more than 50% of the baseline power level. The baseline lighting power shall be determined in accordance with Section 701.4.6.1.1 (7.4.6.1.1). For *building projects* without central lighting controls, DR capabilities for lighting systems shall not be required.

For *spaces* not in the *daylight area* and not connected to automated daylighting control, the lighting levels shall be uniformly reduced throughout the *space*.

Exceptions:

1. Luminaires or signage on emergency circuits.

2. Luminaires located within a *daylight area* that are dimmable and connected to automated daylighting control systems.
3. Lighting systems, including dimming systems, claiming a *lighting power allowance* for *instinctual tuning* in accordance with Section 701.4.6.1.1(f) [7.4.6.1.1(f)].

701.4 (7.4) Prescriptive Option.

701.4.1 (7.4.1) General Comprehensive Prescriptive Requirements. When a requirement is provided below, it supersedes the requirement in ANSI/ASHRAE/IES Standard 90.1. For all other criteria, the *building project* shall comply with the requirements of ANSI/ASHRAE/IES Standard 90.1.

701.4.1.1 (7.4.1.1) On-Site Renewable Energy Systems. *Building projects* shall comply with either the Standard Renewables Approach in Section 701.4.1.1.1 (7.4.1.1.1) or the Alternate Renewables Approach in Section 701.4.1.1.2 (7.4.1.1.2).

701.4.1.1.1 (7.4.1.1.1) Standard Renewables Approach: Baseline On-Site Renewable Energy Systems. *Building projects* shall contain *on-site renewable energy systems* that provide the annual energy production equivalent of not less than 6.0 kBtu/ft² (20 kWh/m²) multiplied by the horizontal projection of the *gross roof area* in feet squared (metres squared) for single-story buildings, and not less than 10.0 kBtu/ft² (32 kWh/m²) multiplied by the horizontal projection of the *gross roof area* in feet squared (metres squared) for all other buildings. The annual energy production shall be the combined sum of all *on-site renewable energy systems*. Documentation shall be provided to the *AHJ* that indicates that the *renewable energy certificates (RECs)* associated with the *on-site renewable energy system* will be retained and retired by the *owner*. Where the *building owner* does not have ownership of the *RECs* associated with the *on-site renewable energy system*, the *owner* shall obtain and retire an equal or greater quantity of *RECs*.

Exceptions: Buildings that demonstrate compliance with both of the following are not required to contain *on-site renewable energy systems*:

1. An annual daily average incident solar radiation available to a flat plate collector oriented due south at an angle from horizontal equal to the latitude of the collector location less than 4.0 kWh/m²-day (1.2 kBtu/ft²/day), accounting for existing buildings, permanent infrastructure that is not part of the *building project*, topography, and trees.
2. A commitment to purchase renewable electricity products complying with the Green-Energy National Standard for Renewable Electricity Products, of at least 7 kWh/ft² (75 kWh/m²) of *conditioned space* each year until the cumulative purchase totals 70

rately, or an area-weighted *PF* value shall be calculated and used for all windows and glass doors. Horizontal projections shall extend over the full width of the glazing.

Exceptions: Permanent projections are not required for the following buildings and fenestrations:

1. Where *vertical fenestration* is located within 18 in. (450 mm) of the lot line.
2. Where equivalent shading of the *vertical fenestration* is provided by buildings, structures, geological formations, or permanent exterior projections that are not horizontal, as determined by sun-angle studies at the peak solar altitude on the summer solstice and three hours before and after the peak solar altitude on the summer solstice.
3. *Vertical fenestration* with automatically controlled shading devices capable of modulating in multiple steps the amount of solar gain and light transmitted into the *space* in response to daylight levels or solar intensity that comply with all of the following:
 - a. Exterior shading devices shall be capable of providing at least 90% coverage of the *fenestration* in the closed position.
 - b. Interior shading devices shall be capable of providing at least 90% coverage of the *fenestration* in the closed position and have a minimum solar reflectance of 0.50 for the surface facing the *fenestration*.
 - c. A manual override located in the same *enclosed space* as the *vertical fenestration* shall override operation of *automatic* controls no longer than four hours.
 - d. Acceptance testing and commissioning shall be conducted as required by Chapter 10 (Section 10) to verify that *automatic* controls for shading devices respond to changes in illumination or radiation intensity.
4. *Vertical fenestration* with automatically controlled *dynamic glazing* capable of modulating in multiple steps the amount of solar gain and light transmitted into the *space* in response to daylight levels or solar intensity that comply with all of the following:
 - a. *Dynamic glazing* shall have a lower labeled *SHGC* equal to or less than 0.12, lowest labeled visible transmittance (VT) no greater than 0.05, and highest labeled VT no less than 0.40.
 - b. A manual override located in the same *enclosed space* as the *vertical fenestration*

shall override operation of *automatic* controls no longer than 4 hours.

- c. Acceptance testing and commissioning shall be conducted as required by Chapter 10 (Section 10) to verify that *automatic* controls for *dynamic glazing* respond to changes in illumination or radiation intensity.

5. Existing buildings undergoing alteration, repair, relocation, or a change of occupancy.

701.4.2.7 (7.4.2.7) SHGC of Vertical Fenestration.

For *SHGC* compliance, the methodology in ANSI/ASHRAE/IES Standard 90.1, Section 5.5.4.4.1, Exception 2, is allowed, provided that the *SHGC* multipliers in Table 701.4.2.7 (7.4.2.7) of this standard are used. This requirement supersedes the requirement in ANSI/ASHRAE/IES Standard 90.1, Table 5.5.4.4.1; that table shall not apply. *Vertical fenestration* that is *north oriented* shall be allowed to have a maximum *SHGC* of 0.10 greater than that specified in ANSI/ASHRAE/IES Standard 90.1, Tables 5.5-1 through 5.5-8. When this provision is used, separate calculations shall be performed for these sections of the *building envelope*, and these values shall not be averaged with any others for compliance purposes.

TABLE 701.4.2.7 (TABLE 7.4.2.7)
SHGC MULTIPLIERS FOR PERMANENT PROJECTIONS

PF	SHGC MULTIPLIER	SHGC MULTIPLIER
	(ALL OTHER ORIENTATIONS)	(NORTH-ORIENTED)
0 to 0.60	1.00	1.00
> 0.60 to 0.70	0.92	0.96
> 0.70 to 0.80	0.84	0.94
> 0.80 to 0.90	0.77	0.93
> 0.90 to 1.00	0.72	0.90

701.4.2.8 (7.4.2.8) Building Envelope Trade-Off Option.

The *building envelope* trade-off option in ANSI/ASHRAE/IES Standard 90.1, Section 5.6, shall not apply unless the procedure incorporates the modifications and additions to ANSI/ASHRAE/IES Standard 90.1 noted in Section 701.4.2 (7.4.2).

701.4.2.9 (7.4.2.9) Orientation. The *vertical fenestration* shall comply with either (a) or (b):

- a. $A_W \leq (A_N + A_S)/4$ and $A_E \leq (A_N + A_S)/4$
- b. $A_W \times SHGC_W \leq (A_N \times SHGC_C + A_S \times SHGC_C)/6$
and $A_E \times SHGC_E \leq (A_N \times SHGC_C + A_S \times SHGC_C)/6$

where:

$SHGC_x$ = the *SHGC* for orientation *x* that complies with Section 701.4.2.7 (7.4.2.7).

$SHGC_C$ = the *SHGC* criteria for each *climate zone* from Section 701.4.2.1 (7.4.2.1).

c. *Outdoor air CO₂* concentrations shall be determined by one of the following:

1. *Outdoor air CO₂* concentrations shall be dynamically measured using one or multiple CO₂ sensors. The CO₂ sensor locations shall be identified on the *construction documents*.
2. When documented statistical data on the local ambient CO₂ concentrations are available, a fixed value typical of the location where the building is located shall be allowed in lieu of an outdoor sensor.

d. Occupant CO₂ generation rate assumptions shall be shown in the design documents.

701.4.3.3 (7.4.3.3) Duct Leakage Tests. Leakage tests shall comply with the requirements in ANSI/ASHRAE/IES Standard 90.1, Section 6.4.4.2.2, with the following modification. Ductwork that is designed to operate at static pressures in excess of 2 in. of water (500 Pa), and all ductwork located outdoors, shall be leak-tested according to industry-accepted test procedures.

701.4.3.4 (7.4.3.4) Economizers. Systems shall include economizers meeting the requirements in ANSI/ASHRAE/IES Standard 90.1, Section 6.5.1, except as modified by the following:

- a. The minimum size requirements for economizers for comfort cooling and for computer rooms are defined in Table 701.4.3.4 (7.4.3.4) and supersede the requirements in ANSI/ASHRAE/IES Standard 90.1, Tables 6.5.1-1 and 6.5.1-2.
- b. Rooftop units with a capacity of less than 54,000 Btu/h (16 kW) shall have two stages of capacity control, with the first stage controlling the economizer and the second stage controlling *mechanical cooling*. Units with a capacity equal to or greater than 54,000 Btu/h (16 kW) shall comply with the staging requirements defined in ANSI/ASHRAE/IES Standard 90.1, Section 6.5.3.1
- c. For systems that control to a fixed leaving air temperature (i.e., *variable-air-volume [VAV]* systems), the system shall be capable of resetting the supply air temperature up at least 5°F (3°C) during economizer operation.

All the exceptions in ANSI/ASHRAE/IES Standard 90.1, Section 6.5.1, shall apply except as modified by the following:

- a. Where the reduced renewable approach defined in Section 701.4.1.1.1 (7.4.1.1.1) is used, ANSI/

ASHRAE/IES Standard 90.1, Section 6.5.1, Exception (9), shall be permitted to eliminate the economizer requirement, provided the requirements in ANSI/ASHRAE/IES Standard 90.1, Table 6.5.1-3, are applied to the efficiency requirements required by Section 701.4.1.1.2 (7.4.1.1.2). If the standard renewable approach is chosen as defined in Section 701.4.1.1.1 (7.4.1.1.1) then the requirements in ANSI/ASHRAE/IES Standard 90.1, Table 6.5.1-3, shall be applied to the efficiency requirements in ANSI/ASHRAE/IES Standard 90.1, Tables 6.8.1-1 through 6.8.1-11.

- b. For water-cooled units with a capacity less than 54,000 Btu/h (16 kW) that are used in systems where heating and cooling loads are transferred within the building (i.e., water-source heat-pump systems), the requirement for an air or water economizer can be eliminated if the condenser-water temperature controls are capable of being set to maintain full-load heat-rejection capacity down to a 55°F (12°C) condenser-water supply temperature, and the HVAC equipment is capable of operating with a 55°F (12°C) condenser-water supply temperature.

701.4.3.5 (7.4.3.5) Zone Controls. The exceptions to ANSI/ASHRAE/IES Standard 90.1, Section (6.5.2.1), shall be modified as follows:

- a. Exception (1) shall not be used.
- b. Exception (2)(a)(2) shall be replaced by the following text: “the design outdoor airflow rate for the zone.”

701.4.3.6 (7.4.3.6) Fan System Power and Efficiency.

701.4.3.6.1 (7.4.3.6.1) Fan System Power Limitation. Systems shall have fan power limitations 10% below limitations specified in ANSI/ASHRAE/IES Standard 90.1, Table 6.5.3.1-1. This requirement supersedes the requirement in ANSI/ASHRAE/IES Standard 90.1, Section (6.5.3.1) and Table (6.5.3.1-1). All exceptions in ANSI/ASHRAE/IES Standard 90.1, Section 6.5.3.1, shall apply.

701.4.3.6.2 (7.4.3.6.2) Fan Efficiency. The fan efficiency requirements defined in ANSI/ASHRAE/IES Standard 90.1, Section 6.5.3.1.3, shall be used, except that the total efficiency of the fan at the design point of operation shall be within ten percentage points of the maximum total efficiency of the fan. All exceptions in ANSI/ASHRAE/IES Standard 90.1, Section 6.5.3.1.3, shall apply.

**TABLE 701.4.3.4 (TABLE 7.4.3.4)
MINIMUM SYSTEM SIZE FOR WHICH AN ECONOMIZER IS REQUIRED**

CLIMATE ZONES	COOLING CAPACITY FOR WHICH AN ECONOMIZER IS REQUIRED ^a
0A, 0B, 1A, 1B	No economizer requirement
2A, 2B, 3A, 3B, 3C, 4A, 4B, 4C, 5A, 5B, 5C, 6A, 6B, 7, 8	≥33,000 Btu/h (9.7 kW) ^a

- a. Where economizers are required, the total capacity of all systems without economizers shall not exceed 480,000 Btu/h (140 kW) per building or 20% of the building’s air economizer capacity, whichever is greater.

701.4.3.7 (7.4.3.7) Exhaust Air Energy Recovery.

The exhaust air energy recovery requirements defined in ANSI/ASHRAE/IES Standard 90.1, Section 6.5.6.1, including the requirements in Tables 6.5.6.1-1 and 6.5.6.1-2, shall be used except that the energy recovery effectiveness shall not be less than 60%, superseding the 50% effectiveness requirement in ANSI/ASHRAE/IES Standard 90.1, Section 6.5.6.1.

701.4.3.8 (7.4.3.8) Kitchen Exhaust Systems. The requirements in ANSI/ASHRAE/IES Standard 90.1, Section 6.5.7.2 shall apply, except as follows: Sections 701.4.3.8.1 (7.4.3.8.1) and 701.4.3.8.2 (7.4.3.8.2) supersede the requirements in ANSI/ASHRAE/IES Standard 90.1, Sections 6.5.7.2.2 and 6.5.7.2.3.

701.4.3.8.1 (7.4.3.8.1) For kitchen/dining facilities with total kitchen hood exhaust airflow rate greater than 2000 cfm (950 L/s), the maximum exhaust flow rate for each hood shall be determined in accordance with Table 701.4.3.8.1 (7.4.3.8.1). For single hoods, or hood sections installed over appliances with different duty ratings, the maximum allowable exhaust flow rate for the hood or hood section shall be determined in accordance with Table 701.4.3.8.1 (7.4.3.8.1) for the highest appliance duty rating under the hood or hood section. Refer to ANSI/ASHRAE Standard 154 for definitions of hood type, appliance duty, and net exhaust flow rate.

Exception: When at least 75% of all the replacement air is *transfer air* that would otherwise be exhausted.

701.4.3.8.2 (7.4.3.8.2) Kitchen/dining facilities with total kitchen hood exhaust airflow rate greater than 2000 cfm (950 L/s) shall comply with at least one of the following:

- a. At least 50% of all replacement air must be *transfer air* that would otherwise be exhausted.
- b. At least 75% of kitchen hood exhaust air shall be controlled by demand ventilation system, which shall:
 - 1. Be capable of reducing exhaust and replacement air system airflow rates by no more than the larger of:

- i. 50% of total design exhaust and replacement air system airflow rate; or
- ii. The outdoor airflow and exhaust rates required to meet the ventilation and exhaust requirements of Sections 6.2 and 6.5 of ASHRAE Standard 62.1 for the zone.

- 2. Include controls to modulate airflow in response to appliance operation and to maintain full capture and containment of smoke, effluent, and combustion products during cooking and idle;
- 3. Include controls that result in full flow when the demand ventilation systems fail to modulate airflow in response to appliance operation; and
- 4. Allow occupants to temporarily override the systems to full flow.

- c. Listed energy recovery devices with a sensible heat recovery effectiveness of not less than 40% shall be applied on at least 50% of the total exhaust airflow.
- d. In *Climate Zones* 0B, 1B, 2B, 3B, 4B, 5B, 6B, 7B, and 8B, when *makeup air* is uncooled or cooled without the use of *mechanical cooling*, the capacity of any nonmechanical *cooling* systems (**Informative Note:** e.g., natural cooling or evaporative cooling) shall be demonstrated to be no less than the system capacity of a *mechanical cooling* system necessary to meet the same loads under design conditions.

701.4.3.9 (7.4.3.9) Duct Insulation. Duct insulation shall comply with the minimum requirements in Normative Appendix A, Tables A-2 and A-3. These requirements supersede the requirements in ANSI/ASHRAE/IES Standard 90.1, Table 6.8.2.

701.4.3.10 (7.4.3.10) Automatic Control of HVAC and Lights in Hotel/Motel Guest Rooms. In hotels and motels with over 50 guest rooms, *automatic controls* for the lighting, switched outlets, television, and HVAC equipment serving each guest room shall be configured according to the following requirements.

**TABLE 701.4.3.8.1 (TABLE 7.4.3.8.1)
MAXIMUM NET EXHAUST FLOW RATE PER LENGTH OF HOOD**

TYPE OF HOOD	LIGHT-DUTY EQUIPMENT		MEDIUM-DUTY EQUIPMENT		HEAVY-DUTY EQUIPMENT		EXTRA-HEAVY-DUTY EQUIPMENT	
	cfm per linear foot	L/s per linear metre	cfm per linear foot	L/s per linear metre	cfm per linear foot	L/s per linear metre	cfm per linear foot	L/s per linear metre
Wall-mounted canopy	140	217	210	325	280	433	385	596
Single island ^a	280	433	350	541	420	650	490	758
Double island (per side)	175	271	210	325	280	433	385	596
Eyebrow	175	271	175	271	Not allowed	Not allowed	Not allowed	Not allowed
Backshelf/Passover	210	325	210	325	280	433	Not allowed	Not allowed

a. The total exhaust flow rate for all single-island hoods in a kitchen/dining facility shall be no more than 5000 cfm (2360 L/s).

**TABLE 701.4.6.1A (TABLE 7.4.6.1A)
LIGHTING POWER DENSITIES USING THE
BUILDING AREA METHOD**

BUILDING AREA TYPE ^a	LPD, W/ft ²	LPD, W/m ²
Automotive facility	0.64	6.9
Convention center	0.51	5.5
Courthouse	0.74	8.0
Dining: Bar lounge/leisure	0.69	7.4
Dining: Cafeteria/fast food	0.66	7.1
Dining: Family	0.61	6.6
Dormitory	0.52	5.6
Exercise center	0.61	6.6
Fire station	0.50	5.4
Gymnasium	0.67	7.2
Health care clinic	0.68	7.3
Hospital	0.86	9.3
Hotel/Motel	0.70	7.5
Library	0.72	7.8
Manufacturing facility	0.60	6.5
Motion picture theater	0.62	6.7
Multifamily	0.49	5.3
Museum	0.68	7.3
Office	0.69	7.4
Parking garage	0.12	1.3
Penitentiary	0.67	7.2
Performing arts theater	0.85	9.1
Police station	0.68	7.3
Post office	0.62	6.7
Religious facility	0.70	7.5
Retail	0.91	9.8
School/university	0.67	7.2
Sports arena	0.76	8.2
Town hall	0.72	7.8
Transportation	0.51	5.5
Warehouse	0.41	4.4
Workshop	0.83	8.9

a. In cases where both a general building area type and a specific building area type are listed, the specific building area type shall apply.

lighting power allowance is permitted in the following cases:

1. For *spaces* in which lighting is specified to be installed in addition to the general lighting for the purpose of decorative appearance or for highlighting art or exhibits, provided that the additional lighting power shall not exceed 0.5W/ft² (5.4 W/m²) of such *spaces*.
2. For lighting equipment installed in sales areas and specifically designed and directed to highlight merchandise, calculate the additional lighting power as follows:

Additional interior *lighting power allowance* =

750 W

+ [Retail Area 1 × 0.40 W/ft² (4.3 W/m²)]
+ [Retail Area 2 × 0.40 W/ft² (4.3 W/m²)]
+ [Retail Area 3 × 1.00 W/ft² (10.8 W/m²)]
+ [Retail Area 4 × 1.50 W/ft² (16.1 W/m²)]

where:

Retail Area 1 = the floor area for all products not listed in Retail Areas 2, 3, or 4.

Retail Area 2 = the floor area used for the sale of vehicles, sporting goods, and small *electronics*.

Retail Area 3 = the floor area used for the sale of furniture, clothing, cosmetics, and artwork.

Retail Area 4 = the floor area used for the sale of jewelry, crystal, and china.

Exception: Other merchandise categories included in Retail Areas 2 through 4 where the *authority having jurisdiction* has approved the documented need for additional lighting power based on visual inspection, contrast, or other critical display.

- e. Any of the control factors from ANSI/ASHRAE/IES Standard 90.1, Table 9.6.3, shall be permitted to be applied, provided that the corresponding control method is not required by ANSI/ASHRAE/ICC/USGBC/IES Standard 189.1.
- f. An additional *lighting power allowance* shall be credited for *institutional tuning* of dimmable lighting systems that meet all of the following requirements:
 1. *Institutional tuning* controls shall be accessible only to authorized personnel.
 2. *Construction documents* shall state that maximum light output or power of controlled lighting shall be reduced by at least 15% from full output.
 3. The maximum light output or power of the controlled lighting shall be measured without *institutional tuning* and with *institutional tuning* to verify reduction of light output or power by at least 15% when tuned. In daylighted areas these measurements shall be conducted at night.

For controlled lighting in daylighted areas, the additional *lighting power allowance* shall be 0.05 times the controlled lighting power. In nondaylighted areas, the additional *lighting power allowance* shall be 0.10 times the controlled lighting power.

**TABLE 701.4.6.1B (TABLE 7.4.6.1B)
LIGHTING POWER DENSITY (LPD) ALLOWANCES AND ROOM CAVITY RATIO (RCR)
THRESHOLDS USING THE SPACE-BY-SPACE METHOD**

Informative Note: This table is divided into two sections. The first section covers *space* types that can be commonly found in multiple-building types. The second part covers *space* types that are typically found in a single-building type.

COMMON SPACE TYPES ^a	LPD, W/ft ²	LPD, W/m ²	RCR THRESHOLD
Atrium			
< 20 ft (6.1 m) in height	0.023/ft total height	0.81/m total height	NA
≥ 20 ft (6.1m) and ≤ 40 ft (12.2 m) in height	0.023/ft total height	0.81/m total height	NA
> 40 ft (12.2 m) in height	0.30 + 0.015/ft total height	3.2 + 0.53/m total height	NA
Audience Seating Area			
Auditorium	0.67	7.2	6
Convention center	0.65	7.0	4
Gymnasium	0.43	4.6	6
Motion picture theater	0.64	6.9	4
Penitentiary	0.44	4.7	4
Performing arts theater	1.34	14.4	8
Religious building	0.98	10.5	4
Sports arena	0.42	4.5	4
All other audience <i>seating</i> areas	0.40	4.3	4
Banking Activity Area	0.79	8.5	6
Breakroom (see Lounge/Breakroom)			
Classroom/Lecture Hall/Training Room			
Penitentiary	1.06	11.4	4
All other <i>classrooms</i> /lecture halls/training rooms	0.74	8.0	4
Conference/Meeting/Multipurpose Room	0.93	10.0	6
Confinement Cells	0.52	5.6	6
Copy/Print Room	0.50	5.4	6
Corridor ^b			
Facility for the visually impaired (and not used primarily by the staff) ^c	0.81	8.7	width < 8 ft (2.4 m)
Hospital	0.81	8.7	width < 8 ft (2.4 m)
Manufacturing facility	0.28	3.0	width < 8 ft (2.4 m)
All other corridors	0.58	6.2	width < 8 ft (2.4 m)
Courtroom	0.98	10.5	6
Computer Room	1.16	12.5	4

- a. In cases where both a common *space* type and a building area specific *space* type are listed, the building area specific *space* type shall apply.
- b. In corridors, the extra LPD allowance is permitted when the width of the corridor is less than 8 ft (2.4 m) and is not based on the RCR, see Section 701.4.6.1.1(c) [7.4.6.1.1(c)].
- c. A “Facility for the visually impaired” is a facility that can be documented as being designed to comply with the light levels in ANSI/IES RP-28 and is licensed or will be licensed by local/state authorities for either senior long-term care, adult daycare, senior support, and/or people with special visual needs.
- d. For accent lighting, see Section 701.4.6.1.1(d) [7.4.6.1.1(d)].
- e. Sometimes referred to as a “picking area.”
- f. Not used to keep footnote numbering consistent with ANSI/ASHRAE/IES Standard 90.1.
- g. Electrical/mechanical rooms. An additional 0.50 W/ft² (5.4 W/m²) shall be allowed, provided that the additional lighting is controlled separately from the base allowance of 0.39 W/ft² (4.2 W/m²). The additional 0.50 W/ft² (5.4 W/m²) allowance shall not be used for any other purpose.
- h. Class of play as defined by IES RP-6.

(continued)

**TABLE 701.4.6.1B (TABLE 7.4.6.1B)
LIGHTING POWER DENSITY (LPD) ALLOWANCES AND ROOM CAVITY RATIO (RCR)
THRESHOLDS USING THE SPACE-BY-SPACE METHOD (Continued)**

Informative Note: This table is divided into two sections. The first section covers *space* types that can be commonly found in multiple-building types. The second part covers *space* types that are typically found in a single-building type.

COMMON SPACE TYPES ^a	LPD, W/ft ²	LPD, W/m ²	RCR THRESHOLD
Dining Area			
Penitentiary	0.72	7.8	6
Facility for the visually impaired (and not used primarily by staff) ^c	1.48	15.9	4
Bar/lounge or leisure dining	0.62	6.7	4
Cafeteria or fast food dining	0.53	5.7	4
Family dining	0.54	5.8	4
All other dining areas	0.53	5.7	4
Electrical/Mechanical Room^g	0.39	4.2	6
Emergency Vehicle Garage	0.53	5.7	4
Food Preparation Area	0.92	9.9	6
Guest Room	0.75	8.1	6
Laboratory			
In or as a <i>classroom</i>	1.04	11.2	6
All other laboratories	1.24	13.3	6
Laundry/Washing Area	0.43	4.6	4
Loading Dock, Interior	0.51	5.5	6
Lobby			
Facility for the visually impaired (and not used primarily by the staff) ^c	1.30	14.0	4
Elevator	0.52	5.6	6
Hotel	0.68	7.3	4
Motion picture theater	0.38	4.1	4
Performing arts theater	0.82	8.8	6
All other lobbies	0.86	9.3	4
Locker Room	0.45	4.8	6
Lounge/Breakroom			
Healthcare facility	0.53	5.7	6
All other lounges/breakrooms	0.44	4.7	4

- a. In cases where both a common *space* type and a building area specific *space* type are listed, the building area specific *space* type shall apply.
- b. In corridors, the extra LPD allowance is permitted when the width of the corridor is less than 8 ft (2.4 m) and is not based on the RCR, see Section 701.4.6.1.1(c) [7.4.6.1.1(c)].
- c. A “Facility for the visually impaired” is a facility that can be documented as being designed to comply with the light levels in ANSI/IES RP-28 and is licensed or will be licensed by local/state authorities for either senior long-term care, adult daycare, senior support, and/or people with special visual needs.
- d. For accent lighting, see Section 701.4.6.1.1(d) [7.4.6.1.1(d)].
- e. Sometimes referred to as a “picking area.”
- f. Not used to keep footnote numbering consistent with ANSI/ASHRAE/IES Standard 90.1.
- g. Electrical/mechanical rooms. An additional 0.50 W/ft² (5.4 W/m²) shall be allowed, provided that the additional lighting is controlled separately from the base allowance of 0.39 W/ft² (4.2 W/m²). The additional 0.50 W/ft² (5.4 W/m²) allowance shall not be used for any other purpose.
- h. Class of play as defined by IES RP-6.

(continued)

TABLE 701.4.6.1B (TABLE 7.4.6.1B)
LIGHTING POWER DENSITY (LPD) ALLOWANCES AND ROOM CAVITY RATIO (RCR)
THRESHOLDS USING THE SPACE-BY-SPACE METHOD (Continued)

Informative Note: This table is divided into two sections. The first section covers *space* types that can be commonly found in multiple-building types. The second part covers *space* types that are typically found in a single-building type.

COMMON SPACE TYPES ^a	LPD, W/ft ²	LPD, W/m ²	RCR THRESHOLD
Office			
Enclosed and ≤ 250 ft ² (23 m ²)	0.85	9.1	8
Enclosed and > 250 ft ² (23 m ²)	0.85	9.1	8
Open plan	0.78	8.4	4
Parking Area, Interior	0.11	1.2	4
Pharmacy Area	1.23	13.2	6
Restroom			
Facility for the visually impaired (and not used primarily by the staff) ^c	0.81	8.7	8
All other restrooms	0.75	8.1	8
Sales Area ^d	1.06	11.4	6
Seating Area, General	0.38	4.1	4
Stairway	The <i>space</i> containing the stairway shall determine the LPD requirements for the stairway.		
Stairwell	0.50	5.4	10
Storage Room			
< 50 ft ² (4.6m ²)	0.86	9.3	6
≥ 50 ft ² (4.6m ²) and ≤ 1000 ft ² (93 m ²)	0.43	4.6	6
All other storage rooms	0.43	4.6	6
Vehicular Maintenance Area	0.53	5.7	4
Workshop	1.09	11.7	6
BUILDING TYPE SPECIFIC SPACE TYPES ^a	LPD, W/ft ²	LPD, W/m ²	RCR THRESHOLD
Facility for the Visually Impaired ^c			
Chapel (used primarily by residents)	0.89	8.9	4
Recreation room/common living room (and not used primarily by staff)	1.53	15.3	6
Automotive (see Vehicular Maintenance Area)			
Convention Center—Exhibit Space	0.69	7.43	4
Dormitory—Living Quarters	0.46	4.95	8
Fire Station—Sleeping Quarters	0.19	2.05	6

- a. In cases where both a common *space* type and a building area specific *space* type are listed, the building area specific *space* type shall apply.
- b. In corridors, the extra LPD allowance is permitted when the width of the corridor is less than 8 ft (2.4 m) and is not based on the RCR, see Section 701.4.6.1.1(c) [7.4.6.1.1(c)].
- c. A “Facility for the visually impaired” is a facility that can be documented as being designed to comply with the light levels in ANSI/IES RP-28 and is licensed or will be licensed by local/state authorities for either senior long-term care, adult daycare, senior support, and/or people with special visual needs.
- d. For accent lighting, see Section 701.4.6.1.1(d) [7.4.6.1.1(d)].
- e. Sometimes referred to as a “picking area.”
- f. Not used to keep footnote numbering consistent with ANSI/ASHRAE/IES Standard 90.1.
- g. Electrical/mechanical rooms. An additional 0.50 W/ft² (5.4 W/m²) shall be allowed, provided that the additional lighting is controlled separately from the base allowance of 0.39 W/ft² (4.2 W/m²). The additional 0.50 W/ft² (5.4 W/m²) allowance shall not be used for any other purpose.
- h. Class of play as defined by IES RP-6.

(continued)

ENERGY EFFICIENCY

**TABLE 701.4.6.1B (TABLE 7.4.6.1B)
LIGHTING POWER DENSITY (LPD) ALLOWANCES AND ROOM CAVITY RATIO (RCR)
THRESHOLDS USING THE SPACE-BY-SPACE METHOD (Continued)**

Informative Note: This table is divided into two sections. The first section covers *space* types that can be commonly found in multiple-building types. The second part covers *space* types that are typically found in a single-building type.

BUILDING TYPE SPECIFIC SPACE TYPES^a	LPD, W/ft²	LPD, W/m²	RCR THRESHOLD
Gymnasium/Fitness Center			
Exercise area	0.50	5.4	4
Playing area	0.75	8.1	4
Healthcare Facility			
Exam/treatment room	1.16	12.5	8
Imaging room	0.98	10.5	6
Medical supply room	0.54	5.8	6
Nursery	0.94	10.1	6
Nurse’s station	0.75	8.1	6
Operating room	1.87	20.1	6
Patient room	0.45	4.8	6
Physical therapy room	0.85	9.1	6
Recovery room	0.89	9.6	6
Library			
Reading area	0.77	8.3	4
Stacks	1.08	11.6	4
Manufacturing Facility			
Detailed manufacturing area	0.86	9.3	4
Equipment room	0.61	6.6	6
Extra high bay area (> 50 ft [15.2 m] floor-to-ceiling height)	0.73	7.9	4
High bay area (25 ft [7.6 m] to 50 ft [15.2 m] floor-to-ceiling height)	0.58	6.2	4
Low bay area (< 25 ft [7.6 m] floor-to-ceiling height)	0.61	6.6	4
Museum			
General exhibition area	0.61	6.6	6
Restoration room	0.77	8.3	6
Performing Arts Theater—Dressing Room	0.35	3.8	6
Post Office—Sorting Area	0.66	7.1	4
Religious Buildings			
Fellowship hall	0.42	4.5	4
Worship/pulpit/choir area	0.98	10.5	4

- a. In cases where both a common *space* type and a building area specific *space* type are listed, the building area specific *space* type shall apply.
- b. In corridors, the extra LPD allowance is permitted when the width of the corridor is less than 8 ft (2.4 m) and is not based on the RCR, see Section 701.4.6.1.1(c) [7.4.6.1.1(c)].
- c. A “Facility for the visually impaired” is a facility that can be documented as being designed to comply with the light levels in ANSI/IES RP-28 and is licensed or will be licensed by local/state authorities for either senior long-term care, adult daycare, senior support, and/or people with special visual needs.
- d. For accent lighting, see Section 701.4.6.1.1(d) [7.4.6.1.1(d)].
- e. Sometimes referred to as a “picking area.”
- f. Not used to keep footnote numbering consistent with ANSI/ASHRAE/IES Standard 90.1.
- g. Electrical/mechanical rooms. An additional 0.50 W/ft² (5.4 W/m²) shall be allowed, provided that the additional lighting is controlled separately from the base allowance of 0.39 W/ft² (4.2 W/m²). The additional 0.50 W/ft² (5.4 W/m²) allowance shall not be used for any other purpose.
- h. Class of play as defined by IES RP-6.

(continued)

**TABLE 701.4.6.1B (TABLE 7.4.6.1B)
LIGHTING POWER DENSITY (LPD) ALLOWANCES AND ROOM CAVITY RATIO (RCR)
THRESHOLDS USING THE SPACE-BY-SPACE METHOD (Continued)**

Informative Note: This table is divided into two sections. The first section covers *space* types that can be commonly found in multiple-building types. The second part covers *space* types that are typically found in a single-building type.

BUILDING TYPE SPECIFIC SPACE TYPES ^a	LPD, W/ft ²	LPD, W/m ²	RCR THRESHOLD
Retail Facilities			
Dressing/fitting room	0.49	5.3	8
Mall concourse	0.79	8.5	4
Sports Arena—Playing Area^b			
Class I facility	2.26	24.3	4
Class II facility	1.45	15.6	4
Class III facility	1.08	11.6	4
Class IV facility	0.72	7.8	4
Transportation Facility			
Baggage/carousel area	0.40	4.3	4
Airport concourse	0.22	2.4	4
Terminal ticket counter	0.48	5.2	4
Warehouse—Storage Area			
Medium-to-bulky, palletized items	0.27	2.9	4
Smaller, hand-carried items ^c	0.65	7.0	6

- a. In cases where both a common *space* type and a building area specific *space* type are listed, the building area specific *space* type shall apply.
- b. In corridors, the extra LPD allowance is permitted when the width of the corridor is less than 8 ft (2.4 m) and is not based on the RCR, see Section 701.4.6.1.1(c) [7.4.6.1.1(c)].
- c. A “Facility for the visually impaired” is a facility that can be documented as being designed to comply with the light levels in ANSI/IES RP-28 and is licensed or will be licensed by local/state authorities for either senior long-term care, adult daycare, senior support, and/or people with special visual needs.
- d. For accent lighting, see Section 701.4.6.1.1(d) [7.4.6.1.1(d)].
- e. Sometimes referred to as a “picking area.”
- f. Not used to keep footnote numbering consistent with ANSI/ASHRAE/IES Standard 90.1.
- g. Electrical/mechanical rooms. An additional 0.50 W/ft² (5.4 W/m²) shall be allowed, provided that the additional lighting is controlled separately from the base allowance of 0.39 W/ft² (4.2 W/m²). The additional 0.50 W/ft² (5.4 W/m²) allowance shall not be used for any other purpose.
- h. Class of play as defined by IES RP-6.

701.4.6.1.2 (7.4.6.1.2) Exterior LPDs. The exterior lighting power allowance shall be determined using ANSI/ASHRAE/IES Standard 90.1, Section 9.4.3, with the following modification. The LPDs from ANSI/ASHRAE/IES Standard 90.1, Table 9.4.2-2, shall be multiplied by the appropriate LPD factor from Table 701.4.6.1.2 (7.4.6.1.2).

701.4.6.2 (7.4.6.2) Occupancy Sensor Controls with Multilevel Switching or Dimming. The lighting in commercial and industrial storage stack areas shall be controlled by an occupant sensor with multilevel switching or dimming system that reduces lighting power a minimum of 50% within 20 minutes of all occupants leaving the stack area.

Exception: Storage stack areas illuminated by high-intensity discharge (HID) lighting with an LPD of 0.8 W/ft² (8.6 W/m²) or less.

701.4.6.3 (7.4.6.3) Automatic Controls for Egress and Security Lighting. Lighting in any area within a

building that is required to be continuously illuminated for reasons of building security or emergency egress shall not exceed 0.1 W/ft² (1 W/m²). Additional egress and security lighting shall be allowed, provided it is controlled by an *automatic* control device that turns off the additional lighting.

701.4.6.4 (7.4.6.4) Controls for Exterior Sign Lighting. This section supersedes ANSI/ASHRAE/IES Standard 90.1, Section 9.4.1.4, for all exterior sign lighting. All exterior sign lighting, including internally illuminated signs and lighting on externally illuminated signs, shall comply with the requirements of Sections 701.4.6.4.1 (7.4.6.4.1) or 701.4.6.4.2 (7.4.6.4.2).

Exceptions:

1. Sign lighting that is specifically required by a health or life safety statute, ordinance, or regulation.
2. Signs in tunnels.

**TABLE 701.4.6.1.2 (TABLE 7.4.6.1.2)
LIGHTING POWER ALLOWANCE FACTORS**

	LIGHTING ZONE				
	LZ0	LZ1	LZ2	LZ3	LZ4
For tradable areas, uncovered parking areas: parking areas and drives with measured <i>SRI</i> < 29 or without <i>SRI</i> measurement	Not allowed	1	0.75	0.83	0.63
For tradable areas, uncovered parking areas: parking areas and drives with new concrete without added color pigment or with measured <i>SRI</i> ≥ 29	Not allowed	1	1	1	1
For tradable areas, other	1.00	0.90	0.90	0.95	0.95
For nontradable areas	1.00	0.95	0.95	0.95	0.95

701.4.6.4.1 (7.4.6.4.1) All sign lighting that operates more than one hour per day during *daylight hours* shall include controls to automatically reduce the input power to a maximum of 35% of full power for a period from one hour after sunset to one hour before sunrise.

Exception: Sign lighting using neon lamps with controls to automatically reduce the input power to a maximum of 70% of full power for a period from one hour after sunset to one hour before sunrise.

701.4.6.4.2 (7.4.6.4.2) All other sign lighting shall include the following:

- a. Controls to automatically reduce the input power to a maximum of 50% of full power for a period from midnight or within one hour of the end of business operations, whichever is later, until 6:00 am or business opening, whichever is earlier.
- b. Controls to automatically turn off during *daylight hours*.

701.4.6.5 (7.4.6.5) Parking and Outdoor Sales Lighting. This section supersedes ANSI/ASHRAE/IES Standard 90.1, Section 9.4.1.4, for lighting serving uncovered parking areas and open areas in outdoor sales lots. Outdoor luminaires serving uncovered parking areas and open areas in outdoor sales lots shall be controlled by all of the following:

- a. Luminaires shall be controlled by a device that automatically turns off the luminaire during *daylight hours*.
- b. Luminaires shall be controlled by a timeclock or other control that automatically turns off the luminaire according to a timed schedule.
- c. For luminaires having a rated input wattage of more than 50 W and where the bottom of the luminaire is mounted 24 ft (7.3 m) or less above the ground, the luminaires shall be controlled by one or more devices that automatically reduce lighting power of each luminaire by a minimum of 50% when there is no activity detected in the controlled zone for a period no longer than 15

minutes. No more than 1500 input watts of lighting power shall be controlled together.

Exceptions:

1. Lighting serving street frontage for vehicle sales lots.
2. Lighting for covered vehicle entrances or exits from buildings or parking structures where required for safety, security, or eye adaptation.

701.4.7 (7.4.7) Other Equipment. The other equipment shall comply with ANSI/ASHRAE/IES Standard 90.1, Section 10, with the following modifications and additions.

701.4.7.1 (7.4.7.1) Equipment Efficiency for the Alternate Renewables Approach. All *building projects* complying with the Alternate Renewables Approach in Section 701.4.1.1.2 (7.4.1.1.2) shall comply with the applicable equipment efficiency requirements in Normative Appendix B and the applicable ENERGY STAR requirements in Section 701.4.7.3.2 (7.4.7.3.2).

701.4.7.2 (7.4.7.2) Supermarket Heat Recovery. Supermarkets with a floor area of 25,000 ft² (2500 m²) or greater shall recover waste heat from the condenser heat rejection on *permanently installed* refrigeration equipment meeting one of the following criteria:

- a. Twenty-five percent (25%) of the refrigeration system full-load total heat rejection.
- b. Eighty percent (80%) of the *space* heat, *service water heating*, and dehumidification reheat.

If a recovery system is used that is installed in the refrigeration system, the system shall not increase the saturated condensing temperature at design conditions by more than 5°F (3°C) and shall not impair other head pressure control/energy reduction strategies.

701.4.7.3 (7.4.7.3) ENERGY STAR Equipment. All *building projects* shall comply with the requirements in Section 701.4.7.3.1 (7.4.7.3.1) and all *building projects* complying with the Alternate Renewables Approach in Section 701.4.1.1.2 (7.4.1.1.2) shall also comply with Section 701.4.7.3.2 (7.4.7.3.2).

- [see also the water efficiency requirements in Section 601.3.2.2 (6.3.2.2)].
2. Dehumidifiers: ENERGY STAR Program Requirements for Dehumidifiers.
 3. Dishwashers: ENERGY STAR Program Requirements Product Specifications for *Residential Dishwashers* [see also the water efficiency requirements in Section 601.3.2.2 (6.3.2.2)].
 4. Refrigerators and freezers: ENERGY STAR Program Requirements for Refrigerators and Freezers.
 5. Room air conditioners: ENERGY STAR Program Requirements and Criteria for Room Air Conditioners.
- b. Heating and Cooling:
1. *Residential* air-source heat pumps: ENERGY STAR Program Requirements for ASHPs and Central Air Conditioners [see also the energy efficiency requirements in Section 701.4.1 (7.4.1)].
 2. *Residential* boilers: ENERGY STAR Program Requirements for Boilers [see also the energy efficiency requirements in Section 701.4.1 (7.4.1)].
 3. *Residential* central air conditioners: ENERGY STAR Program Requirements for ASHPs and Central Air Conditioners [see also the energy efficiency requirements in Section 701.4.1 (7.4.1)].
 4. *Residential* ceiling fans: ENERGY STAR Program Requirements for *Residential Ceiling Fans*.
 5. Dehumidifiers: ENERGY STAR Program Requirements for Dehumidifiers.
 6. *Residential* warm air furnaces: ENERGY STAR Program Requirements for Furnaces.
 7. *Residential* geothermal heat pumps: ENERGY STAR Program Requirements for Geothermal Heat Pumps.
- c. Water Heaters: ENERGY STAR Program Requirements for *Residential Water Heaters*.
- d. Lighting:
1. Lamps: ENERGY STAR Program Requirements for Lamps (Light Bulbs).
 2. Luminaires: ENERGY STAR Program Requirements for Luminaires.
 3. *Residential* light fixtures: ENERGY STAR Program Requirements for *Residential Light Fixtures*.
- e. Commercial Food Service:
1. Commercial refrigerators and freezers: ENERGY STAR Program Require-

ments for Commercial Refrigerators and Freezers.

2. Commercial ice machines: ENERGY STAR Program Requirements for Commercial Ice Machines.

f. Other Products:

1. Battery charging systems: ENERGY STAR Program Requirements for Products with Battery Charger Systems (BCSs).
2. External power adapters: ENERGY STAR Program Requirements for Single-Voltage AC-DC and AC-AC Power Supplies.
3. Vending machines: ENERGY STAR Program Requirements for Refrigerated Beverage Vending Machines.

701.4.7.4 (7.4.7.4) Programmable Thermostats. *Residential* programmable thermostats shall meet the requirements of NEMA Standards Publication DC 3, Annex A, “Energy-Efficiency Requirements for Programmable Thermostats.”

701.4.7.5 (7.4.7.5) Refrigerated Display Cases. All open refrigerated display cases shall be covered by using field-installed strips, curtains, or doors.

701.4.8 (7.4.8) Energy Cost Budget. The Energy Cost Budget option in ANSI/ASHRAE/IES Standard 90.1, Section 11, shall not be used.

701.5 (7.5) Performance Option.

701.5.1 (7.5.1) Annual Energy Cost. The *proposed building performance* cost index with consideration of renewables shall be calculated in accordance with ANSI/ASHRAE/IES Standard 90.1, Normative Appendix G, and be equal to or less than the Performance Cost Index (PCI) Target, as determined from the following equation:

$$PCI_{target} = \frac{BBUEC + (BBREC \times BPF) - REC}{BBUEC + BBREC}$$

where:

PCI_{target} = target PCI required for achieving compliance with the standard, unitless.

BBUEC = the component of *baseline building performance* that is due to *unregulated energy use*, \$.

BBREC = the component of *baseline building performance* that is due to *regulated energy use*, or *baseline building performance* minus BBUEC, \$.

BPF = building performance factor taken from Table 701.5.2A (7.5.2A), unitless.

REC = renewable energy production determined from Section 701.4.1.1.1 (7.4.1.1.1) and converted to cost, \$.

The proposed building PCI, without consideration of renewables, shall comply with the requirements of ANSI/ASHRAE/IES Standard 90.1, Section 4.2.1.1.

On-site renewable energy systems in the proposed design shall be calculated using the procedures in Normative Appendix C. For mixed-use buildings, the building performance factor (BPF) shall be determined by weighting each building type by floor area.

701.5.2 (7.5.2) Annual Carbon Dioxide Equivalent (CO₂e). The *proposed design* shall have an annual CO₂e equal to or less than the annual CO₂e of the *baseline building design* multiplied by the building performance factor (BPF) target determined from Table 701.5.2A (7.5.2A) using the Performance Rating Method in ANSI/ASHRAE/IES Standard 90.1, Normative Appendix G. To determine the annual CO₂e for each energy source in the *baseline building design* and *proposed design*, the energy consumption shall be multiplied by the CO₂e emission factors from Table 701.5.2B (7.5.2B).

**TABLE 701.5.2A (TABLE 7.5.2A)
ENERGY COST AND CO₂e BUILDING
PERFORMANCE FACTORS (BPF)**

BUILDING TYPE	BUILDING PERFORMANCE FACTOR (BPF)
Multifamily	0.71
Healthcare/hospital	0.56
Hotel/motel	0.58
Office	0.54
Restaurant	0.59
Retail	0.50
School	0.37
Semiheated warehouse ^a	0.44
All others	0.54

a. Conditioned warehouses shall use the “All others” category.

**TABLE 701.5.2B (TABLE 7.5.2B)
CO₂e EMISSION FACTORS**

BUILDING PROJECT ENERGY SOURCE	CO ₂ e, lb/MWh	CO ₂ e, kg/MWh
Grid-delivered electricity and other fuels not specified in this table	1348	612
LPG or propane	601	273
Fuel oil (residual)	685	311
Fuel oil (distillate)	663	301
Coal	820	372
Gasoline	681	309
Natural gas	509	231
District chilled water	323	146
District steam	855	388
District hot water	807	366

The values in this table represent national averages for the United States and include both direct and indirect emissions.

CHAPTER 8

INDOOR ENVIRONMENTAL QUALITY (IEQ)

801.1 (8.1) Scope. This section specifies requirements for indoor environmental quality, including indoor air quality, environmental tobacco smoke control, *outdoor air* delivery monitoring, thermal comfort, *building entrances*, acoustic control, *lighting quality*, daylighting, and low-emitting materials.

801.2 (8.2) Compliance. The indoor environmental quality shall comply with Section 801.3 (8.3), “Mandatory Provisions,” and either

- a. Section 801.4 (8.4), “Prescriptive Option,” or
- b. Section 801.5 (8.5), “Performance Option.”

Daylighting and low-emitting materials are not required to use the same option, i.e., prescriptive or performance, for demonstrating compliance.

801.3 (8.3) Mandatory Provisions

801.3.1 (8.3.1) Indoor Air Quality. Buildings shall comply with the design requirements of ANSI/ASHRAE Standard 62.1, Sections 4 through 6, including applicable normative appendices, with the modifications and additions indicated herein. Health care facilities shall comply with the design requirements of ANSI/ASHRAE/ASHE Standard 170, including applicable normative appendices, with the modifications and additions indicated herein. *Residential dwelling units* shall comply with the design requirements of ANSI/ASHRAE Standard 62.2, Sections 4 through 8, with the modifications and additions indicated herein.

Requirements provided in Sections 801.3.1.1 (8.3.1.1) through 801.3.1.7 (8.3.1.7) supersede such requirements in ASHRAE Standard 62.1, ASHRAE Standard 62.2, and ASHRAE/ASHE Standard 170.

801.3.1.1 (8.3.1.1) Minimum Ventilation Rates. In health care facilities, the ventilation requirements of ASHRAE/ASHE Standard 170 shall apply. In *residential dwelling units*, the *dwelling unit* ventilation rates and local exhaust airflow rates as required by ASHRAE Standard 62.2 shall apply. ASHRAE Standard 62.2, Section 4.1.2, shall not apply. In all other cases, ASHRAE Standard 62.1, Sections 6.1.1 and 6.2, shall be used to determine minimum zone and intake outdoor airflow rates. ASHRAE Standard 62.1, Sections 6.1.2 and 6.1.3, shall not apply.

Informative Note: ASHRAE Standard 62.1, Sections 6.1.1 and 6.2, define the Ventilation Rate Procedure for determining ventilation rates.

801.3.1.2 (8.3.1.2) Outdoor Air Delivery Monitoring.

801.3.1.2.1 (8.3.1.2.1) System Design for Outdoor Air Intake Measurement. Each mechanical ventilation system shall be configured to allow for the

measurement of the *outdoor air* intake for use in testing and balancing, recommissioning, and *outdoor air* monitoring as required in Section 801.3.1.2.2 (8.3.1.2.2).

801.3.1.2.2 (8.3.1.2.2) Monitoring Requirements. Each mechanical ventilation system shall have a *permanently installed* device to measure the *minimum outdoor airflow* that meets the following requirements:

- a. The device shall employ methods described in ANSI/ASHRAE Standard 111.
- b. The device shall have an accuracy of $\pm 10\%$ of the *minimum outdoor airflow*. Where the *minimum outdoor airflow* varies, as in *demand control ventilation (DCV)* systems, the device shall maintain this accuracy over the entire range of occupancy and system operation.
- c. The device shall be capable of notifying the building operator, either by activating a local indicator or sending a signal to a building monitoring system, whenever an *outdoor air fault condition* exists. This notification shall require manual reset.

Exception: Constant-volume air supply systems that do not employ *DCV* and that use an indicator to confirm that the intake damper is open to the position needed to maintain the design *minimum outdoor airflow* as determined during system startup and balancing.

801.3.1.3 (8.3.1.3) Filtration and Air Cleaner Requirements.

- a. **Particulate Matter.** The following requirements shall apply in all buildings.

Exceptions: In health care facilities, the particulate filter requirements of ASHRAE/ASHE Standard 170 shall apply.

1. **Wetted Surfaces.** Particulate matter filters or air cleaners having a minimum efficiency reporting value (MERV) of not less than 8 when rated in accordance with ANSI/ASHRAE Standard 52.2 shall be provided upstream of all cooling coils or other devices with wetted surfaces through which air is supplied to an *occupiable space*. These requirements supersede the requirements in ASHRAE Standard 62.1, Section 5.8.

2. **Particulate Matter Smaller than 10 Micrometers (PM10).** Particulate matter filters or air cleaners shall be provided in

TABLE 801.3.3.2 (TABLE 8.3.3.2)
MAXIMUM INTERIOR BACKGROUND SOUND PRESSURE LEVELS FROM BUILDING SYSTEMS AND EXTERIOR SOUND SOURCES ^a

ROOM TYPE	HOURLY AVERAGE SOUND PRESSURE LEVEL (L_{eq})		MAXIMUM SOUND PRESSURE LEVEL (L_{max} [slow time weighting])	
	dBA	dBC	dBA	dBC
Residential sleeping areas (nighttime ^b)	35	60	45	70
Residential living and sleeping areas (daytime)	40	60	50	70
Hotel and motel guest rooms or suites and dormitories	40	60	50	70
Meeting and banquet rooms	35	60	45	70
Corridors and lobbies	45	65	60	75
Service and support areas	45	65	60	75
Enclosed offices	35	60	45	70
Conference rooms	35	60	45	70
Teleconference rooms	30	55	40	65
Open-plan offices	45	65	55	75
Courtrooms—unamplified speech	35	60	45	70
Courtrooms—amplified speech	40	60	50	70
Laboratories—minimal speech communication	55	75	65	85
Laboratories—extensive phone use and speech communication	50	70	60	80
Laboratories—group teaching	40	60	50	70
Religious—general assembly with music program	30	55	40	65
Library study and reading areas	35	60	45	70
Gymnasiums and natatoriums without speech amplification	50	70	60	80
Gymnasiums and natatoriums with speech amplification	55	75	65	85

- a. For high-noise exterior events, refer to Section 801.3.3.2.1 (8.3.3.2.1).
- b. “Nighttime” is defined as the time between 10 p.m. and 7 a.m.

801.3.3.2.3.1 (8.3.3.2.3.1) Building Envelope. The composite sound transmission class (cSTC) for the *building envelope* shall be calculated and used in determining the maximum interior background sound pressure levels for room types listed in Table 801.3.3.2 (8.3.3.2).

801.3.3.2.3.2 (8.3.3.2.3.2) Interior Systems. Interior noise from HVAC systems shall be calculated for room types listed in Table 801.3.3.2 (8.3.3.2) and used in determining the maximum interior background sound pressure levels for the room types listed in Table 801.3.3.2 (8.3.3.2).

801.3.3.2.3.3 (8.3.3.2.3.3) Penetrations and Fenestrations. All penetrations through, and fenestrations within, sound rated assemblies shall be sealed in accordance with ASTM C919 and installed per the manufacturer’s recommendations.

801.3.3.2.3.4 (8.3.3.2.3.4) Inspection. Construction of acoustical items required in Sections 801.3.3.2.3 (8.3.3.2.3) through 801.3.3.2.3.3 (8.3.3.2.3.3) shall be visually inspected by an approved agency.

801.3.3.2.4 (8.3.3.2.4) Interior Background Noise—Testing. Acceptance testing shall be performed in accordance with Section 1001.3.1.1.5 (10.3.1.1.5). Noise from construction activities,

emergency vehicles, and sirens need not be considered.

801.3.3.3 (8.3.3.3) Interior Sound Transmission. Interior *wall* and floor-ceiling assemblies separating adjacent interior *spaces* shall be designed and constructed to provide airborne sound isolation that complies with the minimum cSTC values specified in Table 801.3.3.3 (8.3.3.3). For *wall* and floor-ceiling assemblies separating different room types, the greater of the two cSTC values shall apply. Floor-ceiling assemblies separating adjacent interior *spaces* shall be designed and constructed to provide impact sound isolation that complies with the minimum IIC values specified in Table 801.3.3.3 (8.3.3.3). For floor-ceiling assemblies separating different room types, the IIC value associated with the room on the story below shall apply.

801.3.3.3.1 (8.3.3.3.1) Conformance. Conformance to the requirements in Section 801.3.3.3 (8.3.3.3) shall be demonstrated either through the design requirements of Section 801.3.3.3.2 (8.3.3.3.2) or testing requirements of Section 801.3.3.3.3 (8.3.3.3.3).

801.3.3.3.2 (8.3.3.3.2) Interior Sound Transmission—Design. *Wall* and floor-ceiling assemblies shall comply with the following:

- a. Assemblies shall be required to provide sound isolation in accordance with this sec-

**TABLE 801.3.3.3 (TABLE 8.3.3.3)
MINIMUM SOUND AND IMPACT SOUND RATINGS**

ROOM TYPE	cSTC ^{c,d}	IIC
Dwelling unit (apartment, condominium, duplex, hotel guest room, etc.)	55	55
Retail or restaurant	50	45
Exercise, gym or pool ^b	55	50 ^a
Mechanical, electrical, and elevator machinery rooms ^b	60	N/A ^c
Conference and teleconference rooms	50	50
Enclosed offices	45	45
Open offices	N/A ^c	45

- a. The IIC value listed addresses footfall noise but not exercise-related vibration-borne sound. Exercise-related vibration-borne sound shall comply with the requirements of Section 801.3.3.2 (8.3.3.2).
- b. Minimum cSTC and IIC values are not required between adjacent rooms of the same room type.
- c. For operable partitions and walls containing doors, windows, or both, the minimum cSTC ratings shall be 5 less than the values listed in Table 801.3.3.3 (8.3.3.3).
- d. The minimum cSTC values shall be 5 less than the cSTC values in Table 801.3.3.3 (8.3.3.3) for walls between spaces and corridors and between spaces and open offices. The minimum cSTC values shall be 15 less than the cSTC values specified in Table 801.3.3.3 (8.3.3.3) for walls having doors that open to corridors or open offices.
- e. Not applicable.

tion and shall adjoin other intersecting sound isolating assemblies along all perimeter edges so as to provide continuity of sound isolation.

- b. All partitions between spaces with different uses shall be full-height partitions or shall extend to a ceiling system with a ceiling attenuation class (CAC) rating equal to or greater than the wall cSTC rating, and all floor-ceiling assemblies shall be full-span assemblies connected to the walls/partitions.
- c. Assemblies shall be sealed at all potential flanking paths and around all penetrations according to ASTM C919 and installed in accordance with the sealant manufacturer’s recommendations to achieve the assembly’s required performance rating.

801.3.3.3.2.1 (8.3.3.3.2.1) Inspection. Construction of acoustical items required in Section 801.3.3.3.2 (8.3.3.3.2) shall be visually inspected by an approved agency.

801.3.3.3.3 (8.3.3.3.3) Interior Sound Transmission—Testing. Acceptance testing shall be performed in accordance with Section 1001.3.1.1.5 (10.3.1.1.5).

801.3.3.4 (8.3.3.4) Interior Sound Reverberation. The reverberation time T_{60} for designated spaces shall be calculated in accordance with ANSI/ASA S12.60-2010, Part 1, Annex A, for the octave bands 500, 1000, and 2000 Hz and shall not exceed the values specified in Table 801.3.3.4 (8.3.3.4) for fully furnished rooms.

801.3.3.5 (8.3.3.5) Property Line Sound Levels. Design and construction of mechanical systems for control of sound levels at the property line shall be in accordance with either the design provisions of Section 801.3.3.5.1 (8.3.3.5.1) or the testing provisions of Section 801.3.3.5.2 (8.3.3.5.2).

801.3.3.5.1 (8.3.3.5.1) Property Line Sound Levels—Design. HVAC and other mechanical systems on the premises shall be designed to have a maximum *hourly average sound pressure level* L_{eq} less than or equal to the values in Table 801.3.3.5.1 (8.3.3.5.1) at grade level and up to the highest potential window location on all property lines adjoining receiving properties. When generators are used for emergency power only, they shall be exempt from this criterion.

801.3.3.5.2 (8.3.3.5.2) Property Line Sound Levels—Testing. Sound produced by HVAC or other mechanical systems on the premises shall not exceed the values in Table 801.3.3.5.2 (8.3.3.5.2) at grade level and up to the highest window location on all property lines adjoining receiving properties. Where a generator is used only to provide emergency power, and all periodic operational testing is performed between the hours of 7:00 a.m. and 10:00 p.m., the sound produced by emergency generator during nighttime hours need only comply with the daytime maximum sound level values specified in Table 801.3.3.5.2 (8.3.3.5.2). Acceptance testing shall be performed in accordance with Section 1001.3.1.1.5.1.3 (10.3.1.1.5.1.3).

801.3.4 (8.3.4) Soil-Gas Control. Soil-gas entry into enclosed spaces that are immediately above crawlspaces, slabs-on-grade, and basement slabs shall be controlled in accordance with Sections 801.3.4.1 (8.3.4.1) or 801.3.4.2 (8.3.4.2).

Exceptions:

- 1. Buildings or portions thereof that are not routinely occupied, such as warehouses and parking structures.
- 2. Ventilated garages that comply with ANSI/ASHRAE Standard 62.1, Sections 5.15 and 6.5.

801.3.4.1 (8.3.4.1) Soil-Gas Control Systems.

801.3.4.1.1 (8.3.4.1.1) Soil-Gas Barriers. Soil-gas retarder systems shall be provided and shall comply with all of the following:

- a. Earthen floors in basements and enclosed crawlspaces shall be covered with a soil-gas retarder membrane. Such membrane shall be sealed to the foundation at the edges. Soil-gas retarder membranes or systems shall be placed between slab floors and the base course gas-permeable layer required by Section 801.3.4.1.2 (8.3.4.1.2). Soil-gas retarder materials shall meet or exceed the durability requirements of ASTM E1745, and the installation shall comply with ASTM E1643.

**TABLE 801.3.3.4 (TABLE 8.3.3.4)
MAXIMUM REVERBERATION TIME**

ROOM TYPES	T_{60} , sec
Meeting and banquet rooms < 3000 ft ³ (85 m ³)	0.8
Meeting and banquet rooms 3000 ft ³ (85 m ³) up to 8000 ft ³ (225 m ³)	1.0
Meeting and banquet rooms > 8000 ft ³ (225m ³) up to 30,000 ft ³ (850 m ³)	1.2
Meeting and banquet rooms > 30,000 ft ³ (850 m ³)	1.5
Enclosed offices	0.6
Conference/teleconference rooms	0.6
Open-plan offices	0.6
Courtrooms—unamplified speech	0.7
Courtrooms—amplified speech	1.0
Testing/research labs (tittle speech communication)	1.0
Labs (extensive phone use and speech communication)	0.6
Library study and reading areas	1.0
Gymnasiums and natatoriums	2.0

**TABLE 801.3.3.5.1 (TABLE 8.3.3.5.1)
PROPERTY LINE MAXIMUM SOUND LEVELS—PRESCRIPTIVE OPTION**

INITIATING PROPERTY	RECEIVING PROPERTY	HOURLY AVERAGE SOUND PRESSURE LEVEL L_{eq}
All, except factory or industrial	All, except factory or industrial	50
Factory or industrial	All, except factory or industrial	55
Factory or industrial	Factory or industrial	75

**TABLE 801.3.3.5.2 (TABLE 8.3.3.5.2)
PROPERTY LINE MAXIMUM SOUND LEVELS—TESTED PERFORMANCE OPTION**

INITIATING PROPERTY	RECEIVING PROPERTY	HOURLY AVERAGE SOUND PRESSURE LEVEL L_{eq}	
		DAYTIME	NIGHTTIME
		7:00 A.M. TO 10:00 P.M.	10:00 P.M. TO 7:00 A.M.
All, except factory or industrial	All, except factory or industrial	60	50
Factory or industrial	All, except factory or industrial	65	55
Factory or industrial	Factory or industrial	75	75

Damp-proofing or waterproofing materials shall be installed on the exterior surface of foundation *walls* and shall extend from the top of the footing to above grade.

- b. Joints in concrete around the perimeter of each poured slab section shall be permanently sealed with closed-cell gasket materials or equivalent methods that retain closure after the slab has cured.
- c. Openings in slab floors; below-grade masonry *walls*; and membranes, such as those for plumbing, ground water control systems, soil vent pipes, electrical, mechanical piping, and structural supports, shall be sealed at the penetration with caulk that complies with ASTM C920 class 25 or higher equivalent closed-cell gasket materials or other equivalent method.
- d. Sumps shall be covered with a rigid lid that is mechanically fastened and sealed with a gasket or caulk that will allow removal of the lid for maintenance.

e. Hollow masonry unit *walls* shall be designed and constructed as follows:

1. The first course of masonry units bearing on a footing shall be laid with a full mortar bedding and shall be solid units or fully grouted masonry units.
2. Where portions of masonry units are below grade and in contact with earth, the course of masonry units that is at or partially below grade shall be made of solid masonry units or fully grouted masonry units. Such course of masonry units need not change elevation to compensate for lower-grade elevations along the building perimeter. Openings in *walls* that are below such course of solid or fully grouted masonry units, such as window and door openings, shall be surrounded by solid or fully grouted masonry units.

801.3.4.1.2 (8.3.4.1.2) Gas-Permeable Layer and Soil-Gas Conveyance. There shall be a continuous gas-permeable layer under each slab-on-grade and basement slab for the entire area of the slab and under each membrane installed over earth for the entire area of the membrane. Perforated pipe, geotextile matting, or soil-gas collection pits shall be installed below the slab or membrane and shall be connected to exhaust vent pipe as specified in Section 801.3.4.1.3 (8.3.4.1.3). The gas-permeable layer and soil-gas conveyance pipe shall comply with Table 801.3.4.1.2 (8.3.4.1.2) and (a), (b), or (c) as applicable.

- a. **Stone Aggregate Layer.** The gas-permeable layer shall be a uniform layer not less than 4 in. (0.1 m) in depth and shall consist of gravel or crushed stone that meets ASTM C33 requirements for size numbers 5, 56, 57, or 6. Vent pipe openings to unobstructed interstices between stones within the gas-permeable layer shall not be less than the equivalent values indicated in Table 801.3.4.1.2 (8.3.4.1.2).
- b. **Small Stone, Sand, and Soil.** The gas-permeable layer shall be a uniform layer not less than 4 in. (0.10 m) in depth that consists of any of the following:
 - 1. Small stone aggregates classified in ASTM C33 as size numbers 46, 67, 7, or 8.
 - 2. Sand classified in ASTM C33 as size number 9.
 - 3. Soil that contains less than 35% sand, rock fragment fines, clay, and silt. Such clay and silt shall consist of not more than 10% high-plasticity clay or silt.

Perforated pipe or geotextile drainage matting shall be placed at distances not farther than 20 ft (6 m) apart and not farther than 10 ft (3 m) away from foundation walls or other surfaces that surround the gas-permeable layer. Perforated pipe shall be surrounded by not less than 4 in. (0.10 m) of gas-permeable aggregates that meet ASTM C33 requirements for size numbers 5, 56, 57, or 6. The minimum length and soil-gas inlet openings in the perforated pipe and geotextile matting shall not be less than equivalent values indicated in Table 801.3.4.1.2 (8.3.4.1.2).

- c. **Crawlspace Membranes.** Perforated pipe or equivalent material not less than 10 ft (3 m) in length and 3 in. (0.08 m) in nominal diameter shall be provided under the membrane. The configuration shall allow air movement under the entire area of the membrane.

801.3.4.1.2.1 (8.3.4.1.2.1) Soil-Gas Conveyance Clearance and Dimension. Geotextile mats and perforated pipe shall not be less than 12 in. (0.3 m) and not farther than 10 ft (3 m) from

TABLE 801.3.4.1.2 (TABLE 8.3.4.1.2) SOIL-GAS CONVEYANCE COMPONENTS

SYSTEM VENT PIPE NOMINAL DIAMETER	MINIMUM DIAMETER OF PITS ^a	MINIMUM LENGTH OF PERFORATED PIPE OR GEOTEXTILE MATTING ^b
3 in. (0.08 m)	12 in. (0.30 m) diameter pit	18 ft (5.4 m)
4 in. (0.10 m)	16 in. (0.40) diameter pit	32 ft (10 m)
6 in. (0.15 m)	24 in. (0.60 m) diameter pit	71 ft (22 m)

- a. Pits shall not be less than 4 in. (0.10 m) in depth.
- b. Openings in perforated pipe and geotextile matting shall not be less than 1.0 in.²/ft (21 cm²/m) of pipe or matting length.

foundation walls or other surfaces that surround the gas-permeable layer. Soil-gas inlet openings into the geotextile mats and perforated pipe shall have an area of not less than 1.0 in.²/ft (21 cm²/m) of length. The airway path within geotextile mats and perforated pipe shall not be less than the nominal equivalent area of 3 in. (0.08 cm) pipe inner diameter. Pipe materials below slabs and membranes shall be configured to drain collected water within piping.

801.3.4.1.2.2 (8.3.4.1.2.2) Connections to Exhaust Vent Pipes. Exhaust vent piping, as specified in Section 801.3.4.1.3 (8.3.4.1.3), shall connect to soil-gas inlet configurations within the gas-permeable layer and extend not less than 2 ft (0.6 m) above the top of the slab or membrane. Such pipes shall be temporarily capped or otherwise closed during construction to prevent debris from entering the pipes. The pipe that extends above the slab or membrane shall be labeled with the words “radon vent” or “soil-gas vent” in the prevailing language at the location.

801.3.4.1.3 (8.3.4.1.3) Soil-Gas Exhaust Vent Pipe. Soil-gas exhaust vent piping shall be provided as follows:

- a. **Pipe Placement.** Nonperforated Schedule 40 pipe, as defined by ASTM D1785, shall extend from within the gas-permeable layers to the point of exhaust above the roof. The vent pipe size shall not be reduced at any point between its connection to the gas permeable layers and the exhaust terminal above the roof. Such piping shall be labeled on each floor level of the building with the words “radon vent” or “soil-gas vent” in the prevailing language at the location.
- b. **Multiple Vented Areas.** Where interior footings divide a gas-permeable layer into two or more unconnected areas, such areas shall be interconnected by piping below the slab or membrane or above the slab or membrane. Such piping shall be nonperforated and of a size indicated in Table 801.3.4.1.3 (8.3.4.1.3).

- c. **Provision for Fan.** Soil-gas venting systems shall include a fan or a dedicated *space* for the future installation of a fan. The fan and soil-gas vent piping on the discharge side of the fan shall not be installed within or under occupied *spaces*. A dedicated *space* having a vertical height of not less than 48 in. (1.2 m) and a diameter of not less than 21 in. (0.53 m) shall be provided in the *attic* or other interior area to accommodate the installation of a fan. The fan inlet and outlet vent pipes shall be centered in such dedicated *space*. An electrical supply for the fan shall be provided within 6 ft (1.8 m) of the fan location.
- d. **Vented Area.** The maximum foundation area served by a soil-gas exhaust vent pipe shall be determined in accordance with Table 801.3.4.1.3 (8.3.4.1.3).

Exception: Where inspections verify compliance with Sections 801.3.4.1.1 (8.3.4.1.1) through 801.3.4.1.3 (8.3.4.1.3), the maximum vented area per vent pipe indicated in Table 801.3.4.1 (8.3.4.1) shall be increased by 40%. Where the soil-gas barrier consists of a spray-applied vapor barrier or a geomembrane that provides a homogeneous closure, the maximum vented area per vent pipe shall be increased by an additional 20%.

**TABLE 801.3.4.1.3 (TABLE 8.3.4.1.3)
VENT PIPE DIAMETER PER VENTED AREA**

VENT PIPE DIAMETER	MAXIMUM VENTED AREA PER VENT PIPE
3 in. (0.08 m)	2500 ft ² (230 m ²)
4 in. (0.10 m)	4500 ft ² (420 m ²)
6 in. (0.15 m)	10,000 ft ² (1000 m ²)

801.3.4.2 (8.3.4.2) Alternative Methods of Soil-Gas Control. A soil-gas control system shall be provided, and such system shall be clearly identified or otherwise noted on *construction documents* and shall be approved by a qualified soil-gas professional and the *building project FPT provider*.

801.3.5 (8.3.5) Lighting Quality. The interior lighting and lighting controls shall be installed to meet the requirements of Sections 801.3.5.1 (8.3.5.1) and 801.3.5.2 (8.3.5.2).

801.3.5.1 (8.3.5.1) Enclosed Office Spaces. Lighting for at least 90% of enclosed office *spaces* with less than 250 ft² (23.3 m²) of floor area shall comply with at least one of the following:

- a. Provide *multilevel lighting control*.
- b. Provide *bilevel lighting control* and separate *task lighting*.

801.3.5.2 (8.3.5.2) Multioccupant Spaces. Lighting for conference rooms, meeting rooms, multipurpose rooms, gymnasiums, auditoriums, ballrooms, cafete-

rias, *classrooms*, and other training or lecture rooms shall be provided with *multilevel lighting control*. Lighting settings or the lighting controlled by each manual control shall be labeled at the control devices. The lighting in gymnasiums, auditoriums, ballrooms, and cafeterias shall also consist of at least two separately controlled groups of luminaires.

801.3.6 (8.3.6) Moisture Control. Either a dynamic heat and moisture analysis, in accordance with ANSI/ASHRAE Standard 160, or steady-state water vapor transmission analysis, in accordance with Sections 801.3.6.1 (8.3.6.1) and 801.3.6.2 (8.3.6.2), shall be performed on above-grade portions of the *building envelope* and on interior partitions as described in Section 801.3.6.2 (8.3.6.2). Conditions conducive to condensate formation, as demonstrated by analysis, shall not occur at any location within the *building envelope* or partition components or on the interior side of surfaces not specifically designed and constructed to manage moisture.

Exception: Where analysis indicates that incidental condensate occurs in components engineered to allow or manage such condensate without damage to the *building envelope* components.

801.3.6.1 (8.3.6.1) Exterior Building Envelope. The analysis shall be conducted using the average of at least ten consecutive years of weather data for the *outdoor air* temperature for the warmest three months of the year (summer condition) and the *outdoor air* temperature for the coldest three months of the year (winter condition). The analysis shall include all *building envelope* components, including interior *wall* finishes of the exterior *walls*.

801.3.6.2 (8.3.6.2) Humid Spaces. A separate analysis shall be performed in *spaces* where process or occupancy requirements dictate dew-point conditions that are unique with respect to other *spaces* in the building, such as kitchens, water therapy rooms, swimming-pool enclosures, ice rink enclosures, shower rooms, locker rooms, operating rooms in health care facilities, and exhibit areas in museums.

801.3.6.2.1 (8.3.6.2.1) For exterior *building envelope* components of humid *spaces*, the analysis shall use the *outdoor air* temperature conditions described in Section 801.3.6.1 (8.3.6.1).

801.3.6.2.2 (8.3.6.2.2) For *walls*, floors, and ceilings between occupied *spaces* and adjacent *spaces*, the analysis shall be performed using design summer (cooling) conditions and design winter (heating) conditions of both types of *conditioned space*.

Exception: *Spaces* and their individual mechanical systems that are designed to control condensation and moisture accumulation in the adjacent *building envelope*, *walls*, or ceilings.

801.3.6.3 (8.3.6.3) Flashing of Fenestration, Door Assemblies, Mechanical Equipment, and Other Penetrations of Building Envelope. Flashing or sealants shall be installed around *fenestration*, door assemblies,

and penetrations associated with mechanical equipment and utility services, except where there is a mechanism for drainage to the outdoors or where the materials are designed for long-term contact with water.

801.3.7 (8.3.7) Glare Control. *View fenestration* for the *spaces* listed in Table 801.4.1.2A (8.4.1.2A) shall comply with this section.

View fenestration shall have one or more operable glare control devices capable of reducing the *specular visible transmittance* of the *fenestration* assembly to 3% or less. Such glare control devices shall allow an occupant or control system to change the device's position or light transmission level in order to address glare in the *space*. Operable glare control devices include movable interior window blinds, curtains, and shades; movable exterior louvers, screens, awnings, shades, and blinds; and *dynamic glazing*. Where fabric shades are used, the openness factor, also known as "direct-direct transmittance," shall be tested according to Standard EN14500.

Exceptions:

1. For buildings located greater than 20 degrees latitude north or south of the equator, *view fenestration* oriented within 10 degrees of true north in northern hemisphere locations or within 10 degrees of true south in southern hemisphere location.
2. Where permanent interior or exterior obstructions, such as buildings, structures, overhangs, and fins, have a *specular visible transmittance* of not greater than 3% and block a direct beam of sunlight from passing through the *view fenestration* at a point in the middle of the *view fenestration* both horizontally and vertically, at the peak solar altitude and four hours before and after the peak solar altitude on the summer solstice and the spring equinox as determined by sun-angle studies.
3. *Spaces* that have an *annual sunlight exposure* of not more than 93 fc (1000 lux) of direct sunlight illumination for more than 250 hours per year for less than 3% of the floor area.

801.3.8 (8.3.8) Occupant Override. Occupants shall have the capability to temporarily override *automatic* methods of glare control for periods not exceeding two hours.

801.4 (8.4) Prescriptive Option.

801.4.1 (8.4.1) Daylighting.

801.4.1.1 (8.4.1.1) Daylighting in Large Spaces Directly under a Roof and Having High Ceilings. *Enclosed spaces*, including conditioned and unconditioned *spaces*, meeting all of the following criteria, shall comply with Sections 801.4.1.1.1, 801.4.1.1.2 and 801.4.1.1.3 (8.4.1.1.1, 8.4.1.1.2 and 8.4.1.1.3):

- a. The *space* is in a building with three stories or fewer above grade.
- b. The *space* area is greater than 2500 ft² (232 m²).

- c. The *space* is located directly under a *roof*, and average ceiling heights are greater than 15 ft (4.6 m).

Exceptions:

1. *Spaces* in buildings located in *Climate Zones* 7 or 8.
2. Auditoria, motion picture theaters, performing arts theaters, museums, places of worship, and refrigerated warehouses.
3. *Enclosed spaces* where documentation shows that existing structures or natural objects block direct sunlight on at least 50% of the *roof* over the *enclosed space* at all three of the following times on the date of the spring equinox: three hours before solar noon (peak solar altitude), at solar noon, and three hours after solar noon.

801.4.1.1.1 (8.4.1.1.1) Minimum Daylight Area. Not less than 50% of the floor area shall be in the *daylight area* as defined in Chapter 3 (Section 3). For the purposes of Section 801.4.1.1.1 (8.4.1.1.1), the definition of *daylight area* shall be modified such that partitions and other obstructions that are less than the ceiling height are disregarded. *Daylight areas* shall be under *skylights*, under *roof monitors*, or in the primary or *secondary sidelighted areas* and shall meet not less than one of the following requirements:

- a. The combined area of the *skylights* within the *space* shall not be less than 3% of the calculated *daylight area under skylights*.
- b. The *space* shall have a *skylight effective aperture* of not less than 1%.
- c. The combined area within the *space* of any *vertical fenestration* in *roof monitors* shall not be less than 20% of the calculated *daylight area under roof monitors*.
- d. *Primary sidelighted areas* shall have a *side-lighting effective aperture* of not less than 0.15.
- e. *Secondary sidelighted areas* shall have a *side-lighting effective aperture* of not less than 0.30.

801.4.1.1.2 (8.4.1.1.2) Visible Transmittance (VT) of Skylights and Roof Monitors. The visible transmittance of *skylights* and *roof monitors* for *daylight areas* used to comply with Section 801.4.1.1.1 (8.4.1.1.1) shall not be less than 0.40. For *dynamic glazing*, the highest-labeled VT shall be used for compliance with this section.

Exception: *Enclosed spaces* that have a *skylight effective aperture* of not less than 1%.

801.4.1.1.3 (8.4.1.1.3) Skylight Optical Diffusion Characteristics. *Skylights* used to comply with Section 801.4.1.1.1 (8.4.1.1.1) shall have a glazing material or diffuser that has a measured haze value

greater than 90% when tested according to ASTM D1003 or other test method approved by the *AHJ*.

Exceptions:

1. *Skylights* with a measured haze value less than or equal to 90% and having a combined area not in excess of 5% of the total *skylight* area.
2. *Tubular daylighting devices* having a diffuser.
3. *Skylights* designed to prevent direct sunlight from entering the occupied *space* below during occupied hours.
4. *Skylights* in transportation terminals and concourses, sports arenas, convention centers, atria, and shopping malls.

801.4.1.2 (8.4.1.2) Minimum Sidelighting Effective Aperture for Office Spaces and Classrooms. The *spaces* listed in Table 801.4.1.2A (8.4.1.2A) shall comply with items (a), (b) and (c).

- a. The north-, south-, and east-facing *façades* shall have a minimum *sidelighting effective aperture* as prescribed in Table 801.4.1.2B (8.4.1.2B).
- b. For all *façades*, the combined width of the *primary sidelighted areas* shall not be less than 75% of the length of the *façade wall*.
- c. Opaque interior surfaces in *daylight areas* shall have average visible light reflectances greater than or equal to 80% for ceilings, 40% for partitions higher than 60 in. (1.5 m), and 60% for *walls*.

Exceptions:

1. *Spaces* not adjacent to an exterior *wall*.
2. A *space* that would have tasks or activities requiring routine dark conditions for more than four daytime hours per day.
3. *Spaces* covered by and in compliance with Section 801.4.1.1 (8.4.1.1) without the use of any exception.
4. *Daylight areas* where the height of existing adjacent structures above the window is not less than twice the distance between the window and the adjacent structures, measured from the top of the *glazing*.
5. Existing buildings undergoing alteration, repair, relocation, or a change in occupancy.

801.4.1.3 (8.4.1.3) Shading for Offices. For office *spaces* 250 ft² (23 m²) and larger, each *façade* shall be designed with a shading *projection factor (PF)*. The *PF* shall not be less than 0.5 for the first story above grade and 0.25 for other above-grade stories. Shading is allowed to be external or internal using the *interior PF*. Shading devices shall be limited to the following:

- a. Louvers, sun shades, light shelves, and any other permanent device. Any *vertical fenestration* that

employs a combination of interior and external shading is allowed to be separated into multiple segments for compliance purposes. Each segment shall comply with the requirements for either external or *interior PF*.

- b. Building self-shading through *roof* overhangs or recessed windows.

Exceptions:

1. *Facades* facing within 45 degrees of true north in the northern hemisphere or *façades* facing 45 degrees from true south in the southern hemisphere.
2. Translucent panels and *glazing systems* with a measured haze value greater than 90% when tested according to ASTM D1003 or other test method approved by the *AHJ*, and that are entirely 8 ft (2.5 m) above the floor do not require external shading devices.
3. Where equivalent shading of the *vertical fenestration* is provided by buildings, structures, geological formations, or permanent exterior projections that are not horizontal, as determined by sun-angle studies at the peak solar altitude on the summer solstice and three hours before and after the peak solar altitude on the summer solstice.
4. *Vertical fenestration* with automatically controlled shading devices in compliance with Exception (2) of Section 701.4.2.5 (7.4.2.5).
5. *Vertical fenestration* with automatically controlled *dynamic glazing* in compliance with Exception (3) of Section 701.4.2.5 (7.4.2.5).
6. Existing buildings undergoing alteration, repair, relocation, or a change in occupancy.

**TABLE 801.4.1.2A (TABLE 8.4.1.2A)
DAYLIT SPACES**

Classroom/training room
Conference /meeting/multipurpose room except in convention centers
Lounge/breakroom
Enclosed office and open plan office
Library reading area
Patient rooms and physical therapy rooms within a healthcare facility

**TABLE 801.4.1.2B (TABLE 8.4.1.2B)
MINIMUM SIDELIGHTING EFFECTIVE APERTURE**

CLIMATE ZONE	MINIMUM SIDELIGHTING EFFECTIVE APERTURE
0, 1, 2, 3A, 3B	0.10
3C, 4, 5, 6, 7, 8	0.15

and limited in accordance with the California Air Resources Board Suggested Control Measure for Architectural Coatings.

801.4.2.3 (8.4.2.3) Floor Covering Materials.

Emissions of floor covering materials installed in the building interior, and each product layer within a flooring system containing more than one distinct product layer, shall be individually determined according to CDPH/EHLB/Standard Method V1.1 (commonly known as California Section 01350) and shall comply with the limit requirements for either office or *classroom spaces*, regardless of the *space* type. The emissions testing shall be performed by an ISO/IEC 17025 accredited laboratory that has CDPH/EHLB/Standard Method V.1.1, USEPA TO-17, and ASTM Standard Method D5197 within the scope of its accreditation. Third-party certifiers shall be accredited to ISO/IEC 17065 and have the relevant certification program in the scope of accreditation.

801.4.2.3.1 (8.4.2.3.1) Deemed to Comply.

Floor covering materials that are composed of materials listed in Table 801.4.2.3.1 (8.4.2.3.1) shall be deemed to comply with the requirements of Section 801.4.2.3 (8.4.2.3). Where these products include integral organic-based surface coatings, binders, or sealants, or are installed using adhesives, sealants, paints, or coatings, those products shall be subject to other requirements of Section 801.4.2 (8.4.2).

**TABLE 801.4.2.3.1 (TABLE 8.4.2.3.1)
FLOOR COVERING DEEMED TO COMPLY
WITH VOC EMISSION LIMITS**

Ceramic and concrete tile
Natural stone
Gypsum plaster
Clay masonry
Concrete masonry
Concrete
Metal

801.4.2.4 (8.4.2.4) Composite Wood, Wood Structural Panel, and Agrifiber Products.

Composite wood, wood structural panel, and agrifiber products used on the interior of the building (defined as inside of the *weatherproofing system*) shall contain no added urea-formaldehyde resins. Laminating adhesives used to fabricate on-site and shop-applied composite wood and agrifiber assemblies shall contain no added urea-formaldehyde resins. Composite wood and agrifiber products are defined as follows: particleboard, medium density fiberboard (MDF), wheatboard, strawboard, panel substrates, and door cores. Materials considered furniture, fixtures, and equipment (FF&E) are not considered base building elements and are not included in this requirement.

Emissions for products covered by this section shall be determined according to, and shall comply with, one of the following:

- a. Third-party certification shall be submitted indicating compliance with the California Air Resource Board’s (CARB) regulation, *Airborne Toxic Control Measure to Reduce Formaldehyde Emissions from Composite Wood Products*. Third-party certifier shall be approved by CARB.
- b. CDPH/EHLB/Standard Method V1.1 (commonly referred to as California Section 01350) and shall comply with the limit requirements for either office or *classroom spaces*, regardless of the *space* type.

Exceptions: Structural panel components such as plywood, particle board, wafer board, and oriented strand board identified as “EXPOSURE 1,” “EXTERIOR,” or “HUD-APPROVED” are considered acceptable for interior use.

801.4.2.5 (8.4.2.5) Office Furniture Systems and Seating.

Office furniture systems and *seating* installed prior to occupancy shall comply with the requirements of both Sections 801.4.2.5.1 (8.4.2.5.1) and 801.4.2.5.2 (8.4.2.5.2), based on testing according to ANSI/BIFMA M7.1.

801.4.2.5.1 (8.4.2.5.1) At least 95% of the total number of installed *office furniture system* workstations, and at least 95% of the total number of *seating* units installed, shall comply with ANSI/BIFMA X7.1.

801.4.2.5.2 (8.4.2.5.2) At least 50% of the total number of installed *office furniture system* workstations, and at least 50% of the total number of *seating* units installed, shall comply with Section 7.6.2 of ANSI/BIFMA e3.

801.4.2.6 (8.4.2.6) Ceiling and Wall Assemblies and Systems.

Ceiling and wall assemblies and systems include acoustical treatments, ceiling panels and tiles, gypsum panel products, tackable *wall* panels and coverings, *wall* coverings, and *wall* and ceiling paneling and planking. Emissions from these assemblies and systems shall be determined according to CDPH/EHLB/Standard Method V1.1 (commonly known as California Section 01350) and shall comply with the limit requirements for either office or *classroom spaces*, regardless of the *space* type. The emissions testing shall be performed by an ISO/IEC 17025 accredited laboratory that has CDPH/EHLB/Standard Method V.1.1, USEPA TO-17, and ASTM Standard Method D5197 within the scope of its accreditation. Third-party certifiers shall be accredited to ISO/IEC 17065 and have the relevant certification program in the scope of accreditation.

801.4.2.6.1 (8.4.2.6.1) Deemed to Comply. Ceiling and *wall* assemblies and systems that are composed of materials listed in Table 801.4.2.6.1

INDOOR ENVIRONMENTAL QUALITY (IEQ)

(8.4.2.6.1) shall be deemed to comply with the requirements of Section 801.4.2.6 (8.4.2.6). Where these products include integral organic-based surface coatings, binders, or sealants, or are installed using adhesives, sealants, paints, or coatings, those products shall be subject to other requirements of Section 801.4.2 (8.4.2).

**TABLE 801.4.2.6.1 (TABLE 8.4.2.6.1)
CEILING AND WALL PRODUCTS DEEMED TO
COMPLY WITH VOC EMISSION LIMITS**

Ceramic and concrete tile
Natural stone
Gypsum plaster
Clay masonry
Concrete masonry
Concrete
Metal

801.4.2.7 (8.4.2.7) Insulation. Emissions shall be determined according to CDPH/EHLB/Standard Method V1.1 (commonly known as California Section 01350) and shall comply with the limit requirements for either office or *classroom spaces*, regardless of the *space* type. The emissions testing shall be performed by an ISO/IEC 17025 accredited laboratory that has CDPH/EHLB/Standard Method V.1.1, USEPA TO-17, and ASTM Standard Method D5197 within the scope of its accreditation. Third-party certifiers shall be accredited to ISO/IEC 17065 and have the relevant certification program in the scope of accreditation.

801.4.3 (8.4.3) Lighting for Presentations. Luminaires that are located entirely or partially within 3 ft (0.9 m) horizontally of any *permanently installed* presentation surfaces, including whiteboards, blackboards, chalkboards, and screens for projection units, shall be controlled separately from all other luminaires in the *space* and be capable of being turned off. Control settings for these luminaires shall be labeled at the control device. At least one luminaire shall be located entirely or partially within 3 ft (0.9 m) horizontally of each *permanently installed* whiteboard, blackboard, or chalkboard that is not self-illuminated.

801.5 (8.5) Performance Option.

801.5.1 (8.5.1) Daylight Simulation. For the *spaces* listed in Table 801.4.1.2A (8.4.1.2A), and any *spaces* required to have daylighting in accordance with Section 801.4.1.1 (8.4.1.1), the total floor area shall be calculated, and computer modeling shall be used to determine that the requirements specified in Sections 801.5.1.1 (8.5.1.1) and 801.5.1.2 (8.5.1.2) are met. Computer models shall use an hourly simulation and shall adhere to the modeling protocols described in IES LM 83 for *spatial daylight autonomy* (*sDA*) calculations in Section 801.5.1.1 (8.5.1.1) and *annual sunlight exposure* (*ASE*) calculations in Section 801.5.1.2 (8.5.1.2).

801.5.1.1 (8.5.1.1) Minimum Daylight. The computed area-weighted *sDA* shall not be less than 40%.

The *sDA* within each *space* shall be calculated in accordance with the methodology of IES LM 83. Calculations shall be made on the basis of 28 fc (300 lux) for all *spaces*, with the exception of the following *space* types, which shall be calculated on the basis of 14 fc (150 lux): health-care patient rooms, post-office sorting areas, gymnasias, big box retail, transportation facility terminal ticket counters, airport concourses, and nonrefrigerated warehouses.

Exceptions:

1. A *space* used for tasks or activities requiring routine dark conditions for more than 4 daytime hours per day.
2. A *space* where the height of existing facing structures above the *vertical fenestration* is not less than twice the distance between the *vertical fenestration* and facing structures, measured from the top of the glazing.

801.5.1.2 (8.5.1.2) Excessive Sunlight. The *ASE*, calculated with a threshold of 93 fc (1000 lux) and 250 hours, shall not exceed 20% of the floor area.

Exceptions:

1. Spaces less than 250 ft² (23 m²).
2. *Vertical fenestration* with automatically controlled shading devices in compliance with Section 701.4.2.5 (7.4.2.5), Exception (2).
3. *Vertical fenestration* with automatically controlled *dynamic glazing* in compliance with Section 701.4.2.5 (7.4.2.5), Exception (3).

801.5.2 (8.5.2) Materials. The emissions of all the materials listed below and used within the building (defined as inside of the *weatherproofing system* and applied on-site) shall be modeled for individual VOC concentrations. The sum of each individual VOC concentration from the materials listed below shall be shown to be in compliance with the limits as listed in CDPH/EHLB/Standard Method V1.1 (commonly referred to as California Section 01350), Section 4.3, and shall be compared to 100% of its corresponding listed limit. In addition, the modeling for the building shall include, at a minimum, the criteria listed in Normative Appendix D of this code. Emissions of materials used for modeling VOC concentrations shall be obtained in accordance with the testing procedures of CDPH/EHLB/Standard Method V1.1 unless otherwise noted below.

- a. Tile, strip, panel, and plank products, including vinyl composition tile, resilient floor tile, linoleum tile, wood floor strips, parquet flooring, laminated flooring, and modular carpet tile.
- b. Sheet and roll goods, including broadloom carpet, sheet vinyl, sheet linoleum, carpet cushion, wallcovering, and other fabric.

CHAPTER 9

MATERIALS AND RESOURCES

901.1 (9.1) Scope. This section specifies requirements related to the environmental and human health impacts of materials, including resource conservation, reduced life-cycle impacts of building materials, impacts on the atmosphere, product transparency, and waste management.

901.2 (9.2) Compliance. The building materials shall comply with Section 901.3 (9.3), “Mandatory Provisions,” and either

- a. Section 901.4 (9.4), “Prescriptive Option,” or
- b. Section 901.5 (9.5), “Performance Option.”

901.3 (9.3) Mandatory Provisions.

901.3.1 (9.3.1) Construction Waste Management.

901.3.1.1 (9.3.1.1) Diversion. A minimum of 50% of nonhazardous construction and demolition waste material generated prior to the issuance of the final certificate of occupancy shall be diverted from disposal in landfills and incinerators by reuse, recycling, repurposing, and/or composting. Excavated soil and land-clearing debris shall not be included in the waste diversion calculation. *Alternative daily cover* and waste-to-energy incineration shall not be included as diverted material. All diversion calculations shall be based on either weight or volume, but not both, throughout the construction process.

Informative Note: Reuse includes donation of materials to charitable organizations; salvage of existing materials on-site; reclamation of products by manufacturers; and return of packaging materials to the manufacturer, shipper, or other source for reuse as packaging in future shipments.

901.3.1.2 (9.3.1.2) Total Waste. For new *building projects* on *sites* with less than 5% existing buildings, structures, or *hardscape*, the total amount of construction waste generated prior to the issuance of the final certificate of occupancy on the project shall not exceed 42 yd³ or 12,000 lbs per 10,000 ft² (35 m³ or 6000 kg per 1000 m²) of new building floor area. This shall apply to all waste, whether diverted, landfilled, incinerated, or otherwise disposed of. Excavated soil and land-clearing debris shall not be included in the calculation. The amount of waste shall be tracked throughout the construction process in accordance with the construction waste management plan required in Section 901.3.1.3 (9.3.1.3).

901.3.1.3 (9.3.1.3) Construction Waste Management Plan. Prior to issuance of a demolition or building permit, a preconstruction waste management plan shall be submitted to the *owner*. The plan shall:

- a. identify the construction and demolition waste materials expected to be diverted,

- b. determine whether construction and demolition waste materials are to be source-separated or comingled,
- c. identify service providers and designate destination facilities for construction and demolition waste materials generated at the job *site*, and
- d. identify the average diversion rate for facilities that accept or process comingled construction and demolition materials. Separate average percentages shall be included for those materials collected by construction and demolition materials processing facilities that end up as *alternative daily cover* and incineration.

901.3.2 (9.3.2) Extracting, Harvesting, and/or Manufacturing. This section applies to all materials, products, and/or assemblies installed prior to the issuance of the final certificate of occupancy.

Materials shall be harvested and/or extracted, and products and/or assemblies shall be manufactured, according to the laws and regulations of the country of origin.

Wood products in the project, other than recovered or reused wood, shall not contain wood from endangered wood species unless the trade of such wood conforms with the requirements of the Convention on International Trade in Endangered Species of Wild Fauna and Flora (CITES).

901.3.3 (9.3.3) Refrigerants. Chlorofluorocarbon (CFC) based refrigerants in HVAC&R systems shall not be used. Fire suppression systems shall not contain ozone-depleting substances (CFCs, hydrochlorofluorocarbons [HCFCs], or halons).

901.3.4 (9.3.4) Areas for Storage and Collection of Recyclables and Discarded Goods. Areas for recyclables and discarded goods shall be provided as described in this section. These areas shall be coordinated with the anticipated collection services to maximize the effectiveness of the dedicated areas. Instructions regarding the identification and handling of recyclables and discarded goods in these areas shall be posted in or adjacent to each dedicated area.

901.3.4.1 (9.3.4.1) Recyclables. There shall be areas that serve the entire building and are dedicated to the collection and storage of nonhazardous materials for recycling, including paper, corrugated cardboard, glass, plastics, and metals.

901.3.4.2 (9.3.4.2) Reusable Goods. For *building projects* with *residential spaces*, there shall be an area that serves the entire building and is designed for the collection and storage of discarded but clean items in good condition. Charitable organizations or others to arrange for periodic pickups shall be identified and posted.

**TABLE 901.3.5 (TABLE 9.3.5)
MAXIMUM MERCURY CONTENT FOR ELECTRIC LAMPS**

LAMP	MAXIMUM MERCURY CONTENT
Screw-base compact fluorescent lamps < 25 W	4 mg
Screw-base compact fluorescent lamps ≥ 25 W and < 40 W	5 mg
Pin-base compact fluorescent lamps, all wattages	5 mg
Straight fluorescent T5 normal lifetime lamps ^a	3 mg
Straight fluorescent T8 normal lifetime lamps ^a	4 mg
Straight fluorescent T5 and T8 long lifetime lamps ^b	5 mg
T12 eight-foot straight fluorescent lamps	15 mg

- a. Electric lamps with a rated lifetime less than 25,000 hours when tested on an electronic fluorescent ballast, including T8 instant-start ballasts and T5 programmed-start ballasts, and turned OFF and ON every three hours.
- b. Electric lamps with a rated lifetime equal to or greater than 25,000 hours when tested on an electronic fluorescent ballast, including T8 instant-start ballasts and T5 programmed-start ballasts, and turned OFF and ON every three hours.

comply when the annual average amount of certified wood products purchased by the *vendor*, for which they have chain of custody *verification* not older than two years, is 60% or greater of their total annual wood products purchased.

901.4.1.4 (9.4.1.4) Multiple-Attribute Product Declaration or Certification. A minimum of ten different products installed in the *building project* at the time of issuance of certificate of occupancy shall comply with one of the following subsections. Declarations, reports, and assessments shall be submitted to the *authority having jurisdiction (AHJ)* and shall contain documentation of the critical peer review by an independent third party, results from the review, the reviewer’s name, company name, contact information, and date of the review or certification.

901.4.1.4.1 (9.4.1.4.1) Industry-Wide Declaration. A Type III industry-wide environmental product declaration (EPD) shall be submitted for each product. Where the program operator explicitly recognizes the EPD as fully representative of the product group on a national level, it is considered industry-wide. In the case where an industry-wide EPD represents only a subset of an industry group, as opposed to being industry-wide, the manufacturer shall be explicitly recognized as a participant by the EPD program operator. All EPD shall be consistent with ISO Standards 14025 and 21930, with at least a cradle-to-gate scope. Each product complying with this section shall be counted as one product for compliance with Section 901.4.1.4 (9.4.1.4).

901.4.1.4.2 (9.4.1.4.2) Product-Specific Declaration. A product-specific Type III EPD shall be submitted for each product. The product-specific declaration shall be manufacturer-specific for a product family. Type III EPDs shall be certified as complying with the goal and scope for the cradle-to-gate requirements in accordance with ISO Standards 14025 and 21930. Each product complying with this section shall be counted as two products for compliance with Section 901.4.1.4 (9.4.1.4).

901.4.1.4.3 (9.4.1.4.3) Third-Party Multiattribute Certification. A material-specific assessment shall be submitted for each product in accordance with one of the following standards, where applicable. The assessment shall be certified as meeting the minimum performance level specified in each standard. Each product complying with this section shall be counted as two products for compliance with Section 901.4.1.4 (9.4.1.4).

- a. ANSI/BIFMA e3
- b. NSF/ANSI 140
- c. NSF/ANSI 332
- d. NSF/ANSI 336
- e. NSF/ANSI 342
- f. NSF/ANSI 347
- g. NSC 373
- h. ANSI A138.1
- i. UL 100
- j. UL 102

901.4.1.4.4 (9.4.1.4.4) Product Life Cycle. A report by a third-party that has critically reviewed the *life-cycle assessment (LCA)* of a product, based on ISO Standards 14040 and 14044, shall be submitted. The report shall demonstrate compliance with the goal and scope for the cradle-to-gate requirements. Each product complying with this section shall be counted as two products for compliance with Section 901.4.1.4 (9.4.1.4).

901.5 (9.5) Performance Option

901.5.1 (9.5.1) Life-Cycle Assessment (LCA). An *LCA* shall be performed in accordance with ASTM E2921 and ISO Standard 14044, as modified by this section, for a minimum of two building alternatives, both of which shall conform to the *owner’s project requirements (OPR)*.

901.5.1.1 (9.5.1.1) LCA Performance Metric. The *LCA* shall demonstrate that the final building design achieves one of the following minimum improvements over the reference building design assessed in the *LCA*:

901.3.4.3 (9.3.4.3) Fluorescent and High-Intensity Discharge (HID) Lamps and Ballasts. An area shall be provided that serves the entire building, is designed for the collection and storage of fluorescent and HID lamps and ballasts, and facilitates proper disposal and/or recycling according to jurisdictional hazardous waste requirements.

901.3.4.4 (9.3.4.4) Electronics and Batteries. Separate containers or areas shall be provided that serve the entire building; are designed for the collection and storage of *electronics*, alkaline batteries, and rechargeable batteries; and facilitate disposal and/or recycling according to jurisdictional requirements.

901.3.5 (9.3.5) Mercury Content Levels of Lamps. Electric lamps used in the *building project* shall not contain mercury in an amount exceeding, per lamp, the maximum mercury content levels of Table 901.3.5 (9.3.5).

Exceptions:

1. Eight-foot models of straight fluorescent T8 lamps.
2. High-output and very-high-output, straight fluorescent lamps greater than 1.25 in. (32 mm) in diameter.
3. Mogul bi-pin-based lamps.
4. Preheat straight fluorescent lamps of any size.
5. U-bend and circline fluorescent lamps.
6. HID lamps.
7. Induction lamps.
8. Special-purpose lamps: appliance, black light, germicidal, bug, colored, grow, straight fluorescent reflector, reprographic, shatter resistant, cold temperature, and three-way lamps.

901.4 (9.4) Prescriptive Option.

901.4.1 (9.4.1) Reduced Impact Materials. The *building project* shall comply with any two of the following: Sections 901.4.1.1, 901.4.1.2, 901.4.1.3, or 901.4.1.4 (9.4.1.1, 9.4.1.2, 9.4.1.3, or 9.4.1.4). Calculations shall only include materials *permanently installed* in the project. A value of 45% of the total construction cost shall be permitted to be used in lieu of the actual total cost of materials.

901.4.1.1 (9.4.1.1) Recycled Content and Salvaged Material Content. The sum of the *recycled content* and the *salvaged material* content shall constitute a minimum of 10%, based on cost, of the total materials in the *building project*.

901.4.1.1.1 (9.4.1.1.1) Recycled Content. The *recycled content* of a material shall be the *postconsumer recycled content* plus one-half of the *preconsumer recycled content*, determined by weight (mass). The recycled fraction of the material in a product or an assembly shall then be multiplied by the cost of the product or assembly to determine its contribution to the 10% requirement.

The annual average industry values, by country of production, for the *recycled content* of steel products manufactured in basic oxygen furnaces and electric arc furnaces shall be permitted to be used as the *recycled content* of the steel. For the purpose of calculating the *recycled content* contribution of concrete, the constituent materials in concrete (***Informative Note:*** e.g., the cementitious materials, aggregates, and water) shall be permitted to be treated as separate components and calculated separately.

901.4.1.1.2 (9.4.1.1.2) Salvaged Material Content. The *salvaged material* content shall be determined based on the actual cost of the *salvaged material* or the cost of a comparable alternative component material.

901.4.1.2 (9.4.1.2) Regional Materials. A minimum of 15% of building materials or products used, based on cost, shall be regionally extracted/harvested/recovered or manufactured within a radius of 500 mi (800 km) of the project *site*. If only a fraction of a product or material is extracted/harvested/recovered or manufactured locally, then only that percentage (by weight) shall contribute to the regional value.

Exception: For building materials or products shipped in part by rail or water, the total distance to the project shall be determined by weighted average, whereby that portion of the distance shipped by rail or water shall be multiplied by 0.25 and added to that portion not shipped by rail or water, provided that the total does not exceed 500 mi (800 km).

901.4.1.3 (9.4.1.3) Biobased Products. A minimum of 5% of building materials used, based on cost, shall be *biobased products*. *Biobased products* shall:

- a. comply with the minimum biobased contents of the USDA’s BioPreferred Program;
- b. contain the “USDA Certified *Biobased Product*” label; or
- c. be composed of solid wood, engineered wood, bamboo, wool, cotton, cork, agricultural fibers, or other biobased materials with at least 50% biobased content.

901.4.1.3.1 (9.4.1.3.1) Wood Building Components. Wood building components, including but not limited to structural framing, sheathing, flooring, subflooring, wood window sash and frames, doors, and architectural millwork, used to comply with this requirement shall contain not less than 60% certified wood content tracked through a chain of custody process, either by physical separation or percentage-based approaches, or wood that qualifies as a *salvaged material*. Certified wood content documentation shall be provided by sources certified through a forest certification system with principles, criteria, and standards developed using ISO/IEC Guide 59 or the WTO Technical Barriers to Trade. Wood building components from a *vendor* shall be permitted to

CHAPTER 10

CONSTRUCTION AND PLANS FOR OPERATION

1001.1 (10.1) Scope. This section specifies requirements for construction and plans for operation, including the *commissioning (Cx) process*, building *functional and performance testing (FPT)*, measurement and *verification (M&V)*, energy use reporting, durability, transportation management, erosion and sediment control, construction, and indoor air quality (IAQ) during construction.

1001.2 (10.2) Compliance. All of the provisions of Chapter 10 (Section 10) are mandatory provisions.

1001.3 (10.3) Mandatory Provisions.

1001.3.1 (10.3.1) Construction.

1001.3.1.1 (10.3.1.1) Building Systems FPT. *Functional and performance testing* shall be performed on all building systems specifically referenced in this section using *generally accepted engineering standards* acceptable to the *authority having jurisdiction (AHJ)*.

An *FPT* process and system performance requirements shall be incorporated into *construction documents* and construction schedule of the *building project* to verify system performance.

1001.3.1.1.1 (10.3.1.1.1) FPT Requirements. An *FPT* process shall be performed for the following:

- a. Heating, ventilating, air conditioning, and refrigeration systems (mechanical and passive) and associated controls that exceed total system capacities of 180,000 Btu/h (53,000 W) for cooling, 300,000 Btu/h (88,000 W) for heating, or 10,000 cfm (5000 L/s) for ventilation.
- b. Lighting systems over 5 kW in total capacity, including *automatic* and daylighting controls, manual daylighting controls, occupancy-sensing devices, time switching, and *automatic* shut-off controls.
- c. Domestic water-heating systems rated at over 50,000 Btu/h (15,000 W).
- d. Water pumping and mixing systems over 5 hp (4 kW).
- e. Irrigation systems that use more than 1000 gal (4000 L) per day.

1001.3.1.1.1.1 (10.3.1.1.1.1) Activities Prior to Building Permit for Facilities Using the FPT Process. The following activities shall be completed before a permit is issued for any system requiring *FPT*:

- a. Designate *FPT providers*. For systems that are required to comply with Section 1001.3.1.1.1 (10.3.1.1.1), *FPT providers* shall be *owner's* qualified employees, independent commissioning (*Cx*) providers, or

qualified designers experienced with *FPT* on the designated systems. *FPT providers* shall be independent of the building system design and construction function and shall possess the necessary experience and testing equipment.

- b. *FPT providers* shall review the *construction documents* to verify that the relevant sensor locations, devices, and control sequences are properly specified; performance and testing criteria are included; and equipment to be tested is accessible for testing and maintenance.

1001.3.1.1.1.2 (10.3.1.1.1.2) Activities Prior to Building Occupancy for Facilities Using the FPT Process. Before issuance of a certificate of occupancy, the *FPT providers* shall complete the following activities:

- a. Installation and startup of the specified systems shall be verified.
- b. *FPT* of systems shall be verified.

Exception: Systems for which operation is seasonally dependent, and which cannot be fully commissioned in accordance with the *commissioning (Cx) plan* at the time of occupancy, shall be commissioned at the earliest operation time, postoccupancy, as determined by the *FPT providers*.

- c. The preparation of operation and maintenance (O&M) documentation and warranty information shall be verified. O&M documentation, including the information needed to understand, operate, and maintain the building systems, shall be provided to the building *owner* and facility manager.

1001.3.1.1.1.3 (10.3.1.1.1.3) Documentation. The completed project design and *FPT* documentation shall be provided to the *owner* and shall be retained with the project records.

1001.3.1.1.2 (10.3.1.1.2) Acoustical Control.

1001.3.1.1.2.1 (10.3.1.1.2.1) Acoustical Field Measurement. Where required by Chapter 8 (Section 8), the *FPT* specified in Sections 1001.3.1.1.2.1.1 (10.3.1.1.2.1.1) through 1001.3.1.1.2.1.2 (10.3.1.1.2.1.2) shall be completed.

1001.3.1.1.2.1.1 (10.3.1.1.2.1.1) Interior Background Sound Levels. The interior sound level shall be measured in accordance with ANSI S12.72 using a sound level meter

for all construction activities. The ESC plan shall conform to the erosion and sedimentation control requirements of the most current version of the USEPA NPDES General Permit for Stormwater Discharges from Construction Activities, or local erosion and sedimentation control standards and codes, whichever is more stringent, and regardless of size of project.

1001.3.1.5 (10.3.1.5) IAQ Construction Management. Develop and implement an IAQ construction management plan to include the following:

- a. Air conveyance materials shall be stored and covered so that they remain clean. All filters and controls shall be in place and operational when HVAC systems are operated during building flush-out or baseline IAQ monitoring. Except for system startup, testing, balancing, and commissioning, permanent HVAC systems shall not be used during construction.
- b. After construction ends, prior to occupancy and with all interior finishes installed, a postconstruction, preoccupancy building flush-out as described under Section 1001.3.1.5(b)(1) [10.3.1.5(b)(1)], or postconstruction, preoccupancy baseline IAQ monitoring as described under Section 1001.3.1.5(b)(2) [10.3.1.5(b)(2)], shall be performed:

1. **Postconstruction, preoccupancy flush-out.** A total air volume of *outdoor air* in total air changes as defined by Equation 10-1 shall be supplied while maintaining an internal temperature of a minimum of 60°F (15°C) and relative humidity no higher than 60%. For buildings located in nonattainment areas, filtration and/or air cleaning as described in Section 801.3.1.3 (8.3.1.3) shall be supplied when the Air Quality Index forecast exceeds 100 (category orange, red, purple, or maroon). One of the following options shall be followed:

- i. **Continuous postconstruction, preoccupancy flush-out.** The flush-out shall be continuous and supplied at an outdoor airflow rate no less than that determined in Section 801.3.1.1 (8.3.1.1).
- ii. **Continuous postconstruction, preoccupancy/postoccupancy flush-out.** If occupancy is desired prior to completion of the flush-out, the *space* is allowed to be occupied following delivery to the *space* of half of the total air changes calculated from Equation 10-1. The *space* shall be ventilated at a minimum rate of 0.30 cfm per ft² (1.5 L/s per m²) of *outdoor air*, or the outdoor airflow rate determined in Section 801.3.1.1 (8.3.1.1),

whichever is greater. These conditions shall be maintained until the total air changes calculated according to Equation 10-1 have been delivered to the *space*. The flush-out shall be continuous.

$$TAC = V_{ot} \times \frac{1}{A} \times \frac{1}{H} \times 60 \text{ min/h} \\ \times 24 \text{ h/day} \times 14 \text{ days (I-P)}$$

$$TAC = V_{ot} \times \frac{1 \text{ m}^3}{1000L} \times \frac{1}{A} \times \frac{1}{H} \times 3600 \text{ s/h} \\ \times 24 \text{ h/day} \times 14 \text{ days (SI)}$$

(Equation 10-1)

where:

TAC = total air changes.

V_{ot} = system design *outdoor air* intake flow, cfm (L/s) (according to ANSI/ASHRAE Standard 62.1).

A = floor area, ft² (m²).

H = ceiling height, ft (m).

2. **Postconstruction, preoccupancy baseline IAQ monitoring.** Baseline IAQ testing shall be conducted after construction ends and prior to occupancy. The ventilation system shall be operated continuously, within ±10% of the outdoor airflow rate provided by the ventilation system at design occupancy, for a minimum of 24 hours prior to IAQ monitoring. Testing shall be performed using protocols consistent with the USEPA Compendium of Methods for the Determination of Toxic Organic Pollutants in Ambient Air, TO-1, TO-11, TO-17, and ASTM Standard Method D 5197. The testing shall demonstrate that the *contaminant* maximum concentrations listed in Table 1001.3.1.5 (10.3.1.5) are not exceeded in the return airstreams of the HVAC systems that serve the *space* intended for occupancy. If the return airstream of the HVAC system serving the *space* intended for occupancy cannot be separated from other *spaces*, then for each portion of the building served by a separate ventilation system, the testing shall demonstrate that the *contaminant* maximum concentrations at *breathing zone* listed in Table 1001.3.1.5 (10.3.1.5) are not exceeded in the larger of the following number of locations: (i) no fewer than one location per 25,000 ft² (2500 m²) or (ii) in each contiguous floor area. For each sampling point where the maximum concentration limits are exceeded, conduct additional

**TABLE 1001.3.1.5 (TABLE 10.3.1.5)
MAXIMUM CONCENTRATION OF
AIR POLLUTANTS RELEVANT TO IAQ**

CONTAMINANT	MAXIMUM CONCENTRATION, µg/m ³ (UNLESS OTHERWISE NOTED)
Nonvolatile Organic Compounds	
Carbon monoxide (CO)	9 ppm and no greater than 2 ppm above outdoor levels
Ozone	0.075 ppm (8-h)
Particulates (PM2.5)	35 (24 h)
Particulates (PM10)	150 (24 h)
Volatile Organic Compounds	
Acetaldehyde	140
Acrylonitrile	5
Benzene	60
1,3-butadiene	20
t-butyl methyl ether (methyl-t-butyl ether)	8000
Carbon disulfide	800
Caprolactam ^a	100
Carbon tetrachloride	40
Chlorobenzene	1000
Chloroform	300
1,4-dichlorobenzene	800
Dichloromethane (methylene chloride)	400
1,4-Dioxane	3000
Ethylbenzene	2000
Ethylene glycol	400
Formaldehyde	33
2-Ethylhexanoic acid ^a	25
n-Hexane	7000
1-methyl-2-pyrrolidinone ^a	160
Naphthalene	9
Nonanal ^a	13
Octanal ^a	7.2
Phenol	200
4-phenylcyclohexene (4 PCH) ^a	2.5
2-propanol (isopropanol)	7000
Styrene	900
Tetrachloroethene (tetrachloroethylene, perchloroethylene)	35
Toluene	300
1,1,1-trichloroethane (methyl chloroform)	1000
Trichloroethene (trichloroethylene)	600
Xylene isomers	700
Total volatile organic compounds (TVOC)	— ^b

- a. This test is only required if carpets and fabrics with styrene butadiene rubber (SBR) latex backing material are installed as part of the base building systems.
- b. TVOC reporting shall be in accordance with CDPH/EHLB/Standard Method V1.1 and shall be in conjunction with the individual VOCs listed.

flush-out with *outdoor air*, and retest the specific parameters exceeded to demonstrate that the requirements are achieved. Repeat procedure until all requirements have been met. When retesting noncomplying building areas, take samples from the same locations as in the first test.

1001.3.1.6 (10.3.1.6) Moisture Control. The following items to control moisture shall be implemented during construction:

- a. Materials stored on-site, or materials installed that are absorptive, shall be protected from moisture damage.
- b. Building construction materials that show visual evidence of biological growth due to the presence of moisture shall not be installed on the *building project*.

1001.3.1.7 (10.3.1.7) Construction Activity Pollution Prevention: Idling of Construction Vehicles. Construction-related vehicles shall not idle on the construction *site* for more than five minutes in any 60-minute period, except where necessary to perform their construction-related function. Signage shall be posted at vehicle entrances to the *building project* providing notice of this requirement.

1001.3.1.8 (10.3.1.8) Construction Activity Pollution Prevention: Protection of Occupied Areas. The *construction documents* shall identify operable windows, doors, and air intake openings that serve occupied *spaces*, including those not associated with the *building project*, that are in the area of construction activity or within 35 ft (11 m) of the limits of construction activity. Such windows, doors, and air intake openings that are under control of the *owner* shall be closed, or other measures shall be taken to limit *contaminant* entry.

Management of the affected buildings not under the control of the *building project owner* shall be notified in writing of planned construction activity and possible entry of *contaminants* into their buildings.

1001.3.1.9 (10.3.1.9) Soil-Gas Control. The building shall be tested, postconstruction, for radon in accordance with ANSI/AARST MALB. The indoor radon concentration shall be below 2.7 pCi/L (100 Bq/m³). Where radon testing indicates that the indoor radon concentration is 2.7 pCi/L (100 Bq/m³) or greater, radon mitigation shall be conducted in accordance with ANSI/AARST RMS-LB, and the building shall be retested to verify that the radon concentration is below 2.7 pCi/L (100 Bq/m³).

1001.3.1.10 (10.3.1.10) Construction Waste Management.

1001.3.1.10.1 (10.3.1.10.1) Collection. Specific areas on the construction *site* shall be designated for collection of recyclable and reusable materials. Alternatively, off-site storage and sorting of materials shall be permitted. Diversion efforts shall be tracked throughout the construction process.

2. The survey report shall indicate the percentage of satisfaction for each question in accordance with ASHRAE Standard 55, Section 7.4.1(a).
3. The percentage satisfaction results shall be compared to a nationally recognized survey benchmarking database where the building occupancy category is represented in the databases of nationally recognized organizations.

1001.3.2.2 (10.3.2.2) Maintenance Plan. A *maintenance plan* shall be developed for mechanical, electrical, plumbing, and fire protection systems. The plan shall include the following:

- a. The plan shall be in accordance with ANSI/ASHRAE/ACCA Standard 180 for HVAC systems in buildings that meet the definition of commercial buildings in ASHRAE/ACCA Standard 180.
- b. The plan shall address all elements of ASHRAE/ACCA Standard 180, Section 4, and shall develop required inspection and maintenance tasks similar to ASHRAE/ACCA Standard 180, Section 5, for electrical and plumbing systems in buildings that meet the definition of commercial buildings in ASHRAE/ACCA Standard 180.
- c. *Outdoor air* delivery monitors required by Section 801.3.1.2 (8.3.1.2) shall be visually inspected at least once each quarter and cleaned or repaired, as necessary, and calibrated at the manufacturer’s recommended interval or not less than once per year, whichever is more frequent.
- d. For systems with a damper indicator and with less than 2000 cfm (1000 L/s) of supply air, the system components that control the *minimum outdoor airflow* shall be visually inspected every two years. Records of this inspection shall be maintained on-site either in electronic or written form.
- e. Documentation of the plan and of completed maintenance procedures shall be maintained on the building *site* at all times in:
 1. electronic format for storage on the building energy management system (EMS), building management system (BMS), com-

puterized maintenance management system (CMMS), or other computer storage means, or

2. maintenance manuals specifically developed and maintained for documenting completed maintenance activities.

1001.3.2.3 (10.3.2.3) Service Life Plan. A service life plan that is consistent with the *OPR* shall be developed to estimate to what extent structural, *building envelope* (not mechanical and electrical), and *hardscape* materials will need to be repaired or replaced during the service life of the building. The design service life of the building shall be no less than that determined using Table 1001.3.2.3 (10.3.2.3). The estimated service life shall be documented for building assemblies, products, and materials that will need to be inspected, repaired, and/or replaced during the service life of the building. *Site* improvements and *hardscape* shall also be included. Documentation in the service life plan shall include the *building project* design service life and basis for determination, and the following for each assembly or component:

- a. Building assembly description.
- b. Materials or products.
- c. Design or estimated service life in years.
- d. Maintenance frequency.
- e. Maintenance access for components with an estimated service life less than the service life of the building.

Provide a service life plan at the completion of design development. The *owner* shall retain a copy of the service life plan for use during the life of building.

1001.3.2.4 (10.3.2.4) Transportation Management Plan. A transportation management plan shall be developed compliant with the following requirements. *Owner* shall retain a copy of the transportation management plan.

1001.3.2.4.1 (10.3.2.4.1) All Building Projects. The plan shall include the following:

- a. Preferred parking for carpools and vanpools with parking facilities.
- b. A plan for bicycle transportation.

**TABLE 1001.3.2.3 (TABLE 10.3.2.3)
MINIMUM DESIGN SERVICE LIFE FOR BUILDINGS**

CATEGORY	MINIMUM SERVICE LIFE	BUILDING TYPES
Temporary	Up to 10 years	Nonpermanent construction buildings (sales offices, bunkhouses) Temporary exhibition buildings
Medium life	25 years	Industrial buildings Stand-alone parking structures
Long life	50 years	All buildings not temporary or medium life, including the parking structures below buildings designed for long life category

CHAPTER 11

NORMATIVE REFERENCES

Section numbers indicate where the reference occurs in this document.

AARST

American Association of Radon Scientists and Technologists
475 South Church Street, Suite 600
Hendersonville, NC 28792

ANSI/AARST RMS-LB-2014: Radon Mitigation Standards for Schools and Large Buildings

1001.3.1.9 (10.3.1.9), 1001.3.2.1.4.4 (10.3.2.1.4.4)

ANSI/AARST MALB-2014: Protocols for Measuring Radon and Radon Decay Products in School and Large Buildings

1001.3.1.9 (10.3.1.9), 1001.3.2.1.4.4 (10.3.2.1.4.4)

AHAM

Association of Home Appliance Manufacturers
1111 19th Street NW, Suite 402
Washington, DC, 20036

ANSI/AHAM RAC-1-R2015: Room Air Conditioners

Appendix B

AHRI

Air-Conditioning, Heating, and Refrigeration Institute
2111 Wilson Blvd, Suite 500
Arlington, VA 22201

ANSI/AHRI 210/240-2008 (with Addenda 1 and 2): Performance Rating of Unitary Air-Conditioning and Air-Source Heat Pump Equipment

Appendix B

ANSI/AHRI 310/380-2014: Standard for Packaged Terminal Air-Conditioners and Heat Pumps (CSA-C744-14)

Appendix B

AHRI 340/360-2015 (I-P): Performance Rating of Commercial and Industrial Unitary Air-Conditioning and Heat Pump Equipment

Appendix B

ANSI/AHRI 365-2009: Performance Rating of Commercial and Industrial Unitary Air-Conditioning Condensing Units

Appendix B

ANSI/AHRI 460-2005: Performance Rating of Remote Mechanical-Draft Air-Cooled Refrigerant Condensers

Appendix B

ANSI/AHRI 1230-2010 (with Addendum 2): Performance Rating of Variable Refrigerant Flow (VRF) Multi-Split Air-Conditioning and Heat Pump Equipment

Appendix B

AMCA

Air Movement and Control Association International, Inc.
30 West University Drive
Arlington Heights, IL 60004-1893

ANSI/AMCA 220-05 (R2012): Laboratory Methods of Testing Air Curtain Units for Aerodynamic Performance Rating

701.4.2.4 (7.4.2.4)

ANSI

American National Standards Institute
25 West 43rd Street
New York, NY 20036

ANSI Z21.10.3-2015: Gas Water Heaters, Volume 3, Storage Water Heaters with Input Ratings above 75,000 Btu/h, Circulating and Instantaneous

Appendix B

ANSI Z21.11.2-2013: Gas-fired room heaters, volume II, unvented room heaters

801.3.1.5 (8.3.1.5)

ANSI Z21.47-2012: Gas-Fired Central Furnaces

Appendix B

ANSI Z83.4-2015/CSA 3.7-2015: Non-recirculating direct gas-fired industrial air heaters

801.3.1.5 (8.3.1.5)

ANSI Z83.8-2013: Gas Unit Heaters, Gas Packaged Heaters, Gas Utility Heaters, and Gas-Fired Duct Furnaces

Appendix B

ANSI Z83.19-2009/CSA 2.35-2009: Gas-fired high-intensity infrared heaters

801.3.1.5 (8.3.1.5)

ASA

Acoustical Society of America
1305 Walt Whitman Road
Suite 300
Melville, NY 11747-4300

ANSI/ASA S1.13-2005 (R2010): Measurement of Sound Pressure Levels in Air

1001.3.1.1.2 (10.3.1.1.2)

ANSI/ASA S1.4-2014: Sound Level Meters

1001.3.1.1.2 (10.3.1.1.2)

ANSI/ASA S12.60-2009: Acoustical Performance Criteria, Design Requirements, and Guidelines for Schools, Part 2: Relocatable Classroom Factors

801.3.3 (8.3.3), 801.3.3.4 (8.3.3.4)

ANSI/ASA S12.60-2010: Acoustical Performance Criteria, Design Requirements, and Guidelines for Schools, Part 1: Permanent Schools

801.3.3 (8.3.3)

ANSI/ASA 12.72-2015: Measuring the Ambient Noise Level in a Room

1001.3.1.1.2 (10.3.1.1.2)

ASABE

American Society of Agricultural and Biological Engineers
2950 Niles Road
Saint Joseph, MI 49085

ASABE/ICC 802-2014: Landscape Irrigation Sprinkler and Emitter Standard

601.3.1.2.1 (6.3.1.2.1)

ASHE

American Society for Healthcare Engineering of the American Hospital Association
155 N. Wacker Drive, Suite 400
Chicago, IL 60606

2014 FGI Guidelines: Hospitals and Outpatient Facilities: Guidelines for Design and Construction of Hospitals and Outpatient Facilities

801.3.3 (8.3.3)

2014 FGI Guidelines: Residential Health, Care and Support Facilities: Guidelines for Design and Construction of Residential Health, Care, and Support Facilities

801.3.3 (8.3.3)

ASHRAEASHRAE
1791 Tullie Circle NE
Atlanta, GA 30329**ANSI/ASHRAE Standard 52.2-2017: Method of Testing General Ventilation Air-Cleaning Devices for Removal Efficiency by Particle Size**

801.3.1.3 (8.3.1.3)

ANSI/ASHRAE Standard 55-2017: Thermal Environmental Conditions for Human Occupancy

801.3.2 (8.3.2), 1001.3.2.1.5 (10.3.2.1.5)

ANSI/ASHRAE Standard 62.1-2016: Ventilation for Acceptable Indoor Air Quality

301.2 (3.2), 701.4.3.2 (7.4.3.2), 701.4.3.8 (7.4.3.8), 801.3 (8.3), 1001.3.1.5 (10.3.1.5), 1001.3.2.1.4 (10.3.2.1.4)

ANSI/ASHRAE Standard 62.2-2016: Ventilation and Acceptable Indoor Air Quality in Residential Buildings

801.3.1 (8.3.1), 801.3.1.1 (8.3.1.1), 801.3.1.5 (8.3.1.5)

ANSI/ASHRAE/IES Standard 90.1-2016: Energy Standard for Buildings Except Low-Rise Residential Buildings

301.1 (3.1), 301.2 (3.2), 501.3.6 (5.3.6), 701.3.1 (7.3.1), 701.4.1 (7.4.1), 701.4.2 (7.4.2), 701.4.3 (7.4.3), 701.4.4 (7.4.4), 701.4.5 (7.4.5), 701.4.6 (7.4.6), 701.4.7 (7.4.7), 701.4.8 (7.4.8), 801.3.1.10 (8.3.1.10), 1001.3.1.3.5 (10.3.1.3.5), Appendix A, Appendix B, Appendix C

ANSI/ASHRAE Standard 111-2008: Measurement, Testing, Adjusting, and Balancing of Building HVAC Systems

801.3.1.2.2 (8.3.1.2.2), 1001.3.2.1.4 (10.3.2.1.4), 1001.3.2.1.4.6 (10.3.2.1.4.6)

ANSI/ASHRAE Standard 146-2011: Method of Testing and Rating Pool Heaters

Appendix B

ANSI/ASHRAE Standard 154-2011: Ventilation for Commercial Cooking Operations

701.4.3.8.1 (7.4.3.8.1)

ANSI/ASHRAE Standard 160-2016: Criteria for Moisture-Control Design Analysis in Buildings

801.3.6 (8.3.6)

ANSI/ASHRAE Standard 169-2013: Climatic Data for Building Design Standards

Appendix A

ANSI/ASHRAE/ASHE Standard 170-2013: Ventilation of Health Care Facilities

801.3.1 (8.3.1)

ANSI/ASHRAE/ACCA Standard 180-2012: Standard Practice for Inspection and Maintenance of Commercial Building HVAC Systems

301.2 (3.2), 1001.3.2.2 (10.3.2.2)

ANSI/ASHRAE/IES Standard 202-2013: Commissioning Process for Buildings and Systems

1001.3.1.2 (10.3.1.2), 1001.3.1.3 (10.3.1.3)

ASMEAmerican Society of Mechanical Engineers
Three Park Avenue
New York, NY 10016-5990**ASME A112.18.1-2012/CSA B125.1-12: Plumbing Supply Fittings**

601.3.2.1 (6.3.2.1)

ASME A112.19.2-2013/CSA B45.1-13: Ceramic Plumbing Fixtures

601.3.2.1 (6.3.2.1)

ASME A112.19.14-2013: Six-Liter Water Closets Equipped with a Dual Flushing Device

601.3.2.1 (6.3.2.1)

ASME A112.19.19-2006: Vitreous China Nonwater Urinals

601.3.2.1 (6.3.2.1)

ASTM

ASTM International
100 Barr Harbor Dr.
West Conshohocken, PA 19428-2959

- ASTM C33: Standard Specification for Concrete Aggregates**
801.3.4.1.2 (8.3.4.1.2)
- ASTM C518-15: Standard Test Method for Steady-State Thermal Transmission Properties by Means of the Heat Flow Meter Apparatus**
Appendix A
- ASTM C919-12: Standard Practice for Use of Sealants in Acoustical Applications.**
801.3.3.1.1 (8.3.3.1.1), 801.3.3.2.3.3 (8.3.3.2.3.3), 801.3.3.3.2 (8.3.3.3.2)
- ASTM C920-14: Standard Specification for Elastomeric Joint Sealants**
801.3.4.1.1 (8.3.4.1.1)
- ASTM C1371-15: Standard Test Method for Determination of Emittance of Materials Near Room Temperature Using Portable Emissometers**
501.3.5.4 (5.3.5.4)
- ASTM C1549-09(2014): Standard Test Method for Determination of Solar Reflectance Near Ambient Temperature Using a Portable Solar Reflectometer**
501.3.5.4 (5.3.5.4)
- ASTM D1003-13: Standard Test Method for Haze and Luminous Transmittance of Transparent Plastics**
301.2 (3.2), 801.4 (8.4), 801.4.1.1.3 (8.4.1.1.3), 801.4.1.3 (8.4.1.3)
- ASTM D1785-15: Standard Specification for Poly(Vinyl Chloride) (PVC) Plastic Pipe, Schedules 40, 80, and 120**
801.3.4.1.3 (8.3.4.1.3)
- ASTM D5197-09e1: Standard Test Method for Determination of Formaldehyde and Other Carbonyl Compounds in Air (Active Sampler Methodology)**
801.4.2 (8.4.2), 1001.3.1.5 (10.3.1.5)
- ASTM E90-09: Standard Test Method for Laboratory Measurement of Airborne Sound Transmission Loss of Building Partitions and Elements**
801.3.3.1.1 (8.3.3.1.1)
- ASTM E336-14: Standard Test Method for Measurement of Airborne Sound Attenuation Between Rooms in Buildings**
801.3.3.1.1 (8.3.3.1.1), 1001.3.1.1.5.1.2 (10.3.1.1.5.1.2)
- ASTM E408-13: Standard Test Methods for Total Normal Emittance of Surfaces Using Inspection-Meter Techniques**
501.3.5.4 (5.3.5.4)
- ASTM E492-09s: Standard Test Method for Laboratory Measurement of Impact Sound Transmission through Floor-Ceiling Assemblies Using the Tapping Machine**
801.3.3.1.1 (8.3.3.1.1)
- ASTM E779-10: Standard Test Method for Determining Air Leakage Rate by Fan Pressurization**
1001.3.1.3.5 (10.3.1.3.5)
- ASTM E972-96 (2013): Standard Test Method for Solar Photometric Transmittance of Sheet Materials Using Sunlight**
301.2 (3.2)
- ASTM E1007-14: Standard Test Method for Field Measurement of Tapping Machine Impact Sound Transmission through Floor-Ceiling Assemblies and Associated Support Structures**
801.3.3.1.1 (8.3.3.1.1)
- ASTM E1643-11: Standard Practice for Selection, Design, Installation, and Inspection of Water Vapor Retarders Used in Contact with Earth or Granular Fill Under Concrete Slabs**
801.3.4.1.1 (8.3.4.1.1)
- ASTM E1745-11: Standard Specification for Plastic Water Vapor Retarders Used in Contact with Soil or Granular Fill under Concrete Slabs**
801.3.4.1.1 (8.3.4.1.1)
- ASTM E1827-11: Standard Test Methods for Determining Airtightness of Buildings Using an Orifice Blower Door**
1001.3.1.3.5 (10.3.1.3.5)
- ASTM E1903-11: Standard Practice for Environmental Site Assessments: Phase II Environmental Site Assessment Process**
301.2 (3.2)

ASTM—continued

- ASTM E1918-06(2015): Standard Test Method for Measuring Solar Reflectance of Horizontal and Low-Sloped Surfaces in the Field**
501.3.5.4 (5.3.5.4)
- ASTM E1980-11: Standard Practice for Calculating Solar Reflectance Index of Horizontal and Low-Sloped Opaque Surfaces**
501.3.5.4 (5.3.5.4)
- ASTM E2399-11: Standard Test Method for Maximum Media Density for Dead Load Analysis of Vegetative (Green) Roof Systems**
501.3.5.5 (5.3.5.5)
- ASTM E2843-17: Standard Specification for Demonstrating that a Building is in Walkable Proximity to Neighborhood Assets**
501.3.1.1 (5.3.1.1)
- ASTM E2844-15e1: Standard Specification for Demonstrating That a Building’s Location Provides Access to Public Transit**
501.3.1.1 (5.3.1.1)
- ASTM E2921-16: Standard Practice for Minimum Criteria for Comparing Whole Building Life Cycle Assessments for Use with Building Codes and Rating Systems**
901.5.1 (9.5.1)

BIFMA

Business and Institutional Furniture Manufacturer’s Association
678 Front Avenue NW, Suite 150
Grand Rapids, MI 49504-5368

- ANSI/BIFMA e3-2014: Furniture Sustainability Standard**
801.4.2.5 (8.4.2.5), 901.4.1.4.3 (9.4.1.4.3)
- ANSI/BIFMA M7.1-2011 (R2016): Standard Test Method For Determining VOC Emissions From Office Furniture Systems, Components and Seating**
801.4.2.5 (8.4.2.5), 801.5.2 (8.5.2)
- ANSI/BIFMA X7.1-2011 (R2016): Standard for Formaldehyde and TVOC Emissions of Low-Emitting Office Furniture Systems and Seating**
801.4.2.5 (8.4.2.5)

CARB

California Air Resources Board
1001 “I” Street
P.O. Box 2815
Sacramento, CA 95812

- CARB SCM for Architectural Coatings-2007: California Air Resources Board (ARB) Suggested Control Measure for Architectural Coatings**
801.4.2.2.2 (8.4.2.2.2)
- No-Added Formaldehyde Based Resins: Airborne Toxic Control Measure to Reduce Formaldehyde Emissions from Composite Wood Products. California Code of Regulations, Title 17, Sections 93120-93120.12**
801.4.2.4 (8.4.2.4)

CDPH

California Department of Public Health
Indoor Air Quality Section
850 Marina Bay Parkway
Richmond, CA 94804

- CDPH/EHLB/Standard Method V1.1 (2010): Standard Method for the Testing and Evaluation of Volatile Organic Chemical Emissions from Indoor Sources Using Environmental Chambers—Version 1.1**
801.4.2 (8.4.2), 801.5.2 (8.5.2), Table 1001.3.1.5 (Table 10.3.1.5), Appendix D

CEN

European Committee for Standardization
Avenue Marnix 17—B-1000
Brussels, Belgium

- EN14500:2008: Blinds and shutters—Thermal and visual comfort—Test and calculation methods**
801.3.8 (8.3.8)

NORMATIVE REFERENCES

CGSB

Canadian General Standards Board
Place du Portage III, 6B1
11 Laurier Street
Gatineau, Quebec K1A 1G6, Canada

CAN/CGSB 149.10-M86: Determination of the Airtightness of Building Envelopes by the Fan Depressurization Method

1001.3.1.3.5 (10.3.1.3.5)

CAN/CGSB 149.15-96: Determination of the Overall Envelope Airtightness of Buildings by the Fan Pressurization Method Using the Building's Air Handling Systems

1001.3.1.3.5 (10.3.1.3.5)

CITES

Convention on International Trade in Endangered Species of Wild Fauna and Flora
International Environment House
11 Chemin des Anémones
CH-1219 Châtelaine, Geneva, Switzerland

CITES- 1973, amended 1979 and 1983: Convention on International Trade in Endangered Species of Wild Fauna and Flora

901.3.2 (9.3.2)

CRRC

Cooling Roof Rating Council
449 15th Street, Suite 400
Oakland, CA 94612

ANSI/CRRC S100-2016: Standard Test Methods for Determining Radiative Properties of Materials

501.3.5.4 (5.3.5.4)

CTI

Cooling Technology Institute
PO Box 681807
Houston, TX 77268

CTI ATC-105 (00): Acceptance Test Code for Water Cooling Towers

Appendix B

CTI ATC-105S (11): Acceptance Test Code for Closed-Circuit Cooling Towers

Appendix B

CTI ATC-106 (11): Acceptance Test Code for Mechanical Draft Evaporative Vapor Condensers

Appendix B

CTI STD-201RS (15): Standard for the Certification of Water Cooling Tower Thermal Performance

Appendix B

Green-e

Green-e
c/o Center for Resource Solutions
1012 Torney Ave., Second Floor
San Francisco, CA 94129

Version 2.8, April 1, 2016: Green-e Energy National Standard for Renewable Electricity Products

701.4.1.1.1 (7.4.1.1.1)

GS

Green Seal
1001 Connecticut Avenue, NW, Suite 827
Washington, DC 20036-5525

GS-11, 3.2, October 26, 2016: Green Seal Standard for Paints, Coatings, Stains, and Sealers. Section 3.0: "Product-Specific Health and Environmental Requirements"

801.4.2.2.2 (8.4.2.2.2)

GS-36, 2.1, July 12, 2013: Standard for Adhesives for Commercial Use

801.4.2.1.2 (8.4.2.1.2)

GS-42, July 7, 2015: Standard for Commercial and Institutional Cleaning Services

1001.3.2.1.4.5 (10.3.2.1.4.5)

IA

Irrigation Association
8280 Willow Oaks Corporate Drive, Suite 400
Fairfax, VA 22031

Smart Water Application Technologies (SWAT) Climatologically Based Controllers, 8th Testing Protocol—September 2008: Smart Water Application Technologies (SWAT), Turf and Landscape Irrigation System Smart Controllers, Climatologically Based Controllers

301.2 (3.2), 601.3.1.2.2 (6.3.1.2.2)

IAPMO

International Association of Plumbing and Mechanical Officials
5001 East Philadelphia Street
Ontario, CA 91761

Z124.9-2004: Plastic Urinal Fixtures

601.3.2.1 (6.3.2.1)

ICC

International Code Council
500 New Jersey Ave NW # 300
Washington, DC 20001

2018 IBC: International Building Code®

102.4, 102.6, 104.1

2018 IECC: International Energy Conservation Code®

102.4

2018 IEBC: International Existing Building Code®

102.4, 102.6

2018 IFC: International Fire Code®

102.4, 102.6, 501.3.5.5 (5.3.5.5)

2018 IFGC: International Fuel Gas Code®

102.4

2018 IMC: International Mechanical Code®

102.4

2018 IPC: International Plumbing Code®

102.4, 601.3.5.3 (6.3.5.3)

2018 IPMC: International Property Maintenance Code®

102.4, 102.6

2018 IRC: International Residential Code®

101.3.2 (2.2), 102.4

2018 ICC PC: Performance Code for Buildings and Facilities®

102.4

IES

Illuminating Engineering Society
120 Wall Street, Floor 17
New York, NY 10005-4001

TM-15-2011 including addendum a: Luminaire Classification System for Outdoor Luminaires

501.3.6.2 (5.3.6.2)

LM-83-12: Approved Method: IES Spatial Daylight Autonomy (sDA) and Annual Sunlight Exposure (ASE)

301.2 (3.2), 801.5.1 (8.5.1)

NORMATIVE REFERENCES

ISO

International Organization for Standardization
ISO Central Secretariat, 1 rue de Varembée, Case postale 56
CH-1211 Geneva 20, Switzerland

- ISO-9972-2015: Thermal Performance of Buildings—Determination of Air Permeability of Buildings—Fan Pressurization Method**
1001.3.1.3.5 (10.3.1.3.5)
- ISO-13256-1-1998: Water-Source Heat Pumps—Testing and Rating for Performance—Part 1: Water-to-Air and Brine-to-Air Heat Pumps**
Appendix B
- ISO-13256-2-1998: Water-Source Heat Pumps—Testing and Rating for Performance—Part 2: Water-to-Water and Brine-to-Water Heat Pumps**
Appendix B
- ISO 14025-2006: Environmental Labels and Declarations—Type III Environmental Declarations—Principles and Procedures**
901.4.1.4 (9.4.1.4)
- ISO 14040-2006: Environmental Management—Life Cycle Assessment—Principles and Framework**
901.4.1.4 (9.4.1.4)
- ISO 14044-2006: Environmental Management—Life Cycle Assessment— Requirements and Guidelines**
901.5.1 (9.5.1), 901.5.1.2 (9.5.1.2)
- ISO 21930-2007: Sustainability in Building Construction—Environmental Declaration of Building Products**
901.4.1.4 (9.4.1.4)
- ISO/IEC-17025-2005 (Reviewed 2010): General Requirements for the Competence of Testing and Calibration Laboratories**
801.4.2 (8.4.2)
- ISO/IEC 17065-2012: Conformity Assessment—Requirements for Bodies Certifying Products, Processes, and Services**
801.4.2 (8.4.2)
- ISO/IEC Guide 59-1994: Code of Good Practice for Standardization**
901.4.1.3.1 (9.4.1.3.1)

NEMA

National Electrical Manufacturers Association
1300 North 17th Street, Suite 900
Rosslyn, VA 22209

- ANSI/NEMA MG 1-2009: Motors and Generators**
701.4.3.1 (7.4.3.1)
- NEMA DC 3, Annex A-2013: Energy-Efficiency Requirements for Programmable Thermostats**
701.4.7.4 (7.4.7.4)

NFPA

National Fire Protection Association
1 Battery March Park
Quincy, MA 02169-7471

- NFPA 70-2014: National Electrical Code**
501.3.6.3 (5.3.6.3)

NFRC

National Fenestration Rating Council
6305 Ivy Lane, Suite 140
Greenbelt, MD 20770-6323

- ANSI/NFRC 200-2014: Procedure for Determining Fenestration Product Solar Heat Gain Coefficients and Visible Transmittance at Normal Incidence**
301.2 (3.2)

NSC

Natural Stone Council
P.O. Box 539
Hollis, NH 03049

NSC 373-2013: Sustainable Production of Natural Dimension Stone
901.4.1.4 (9.4.1.4)

NSF

NSF International
789 Dixboro Road
Ann Arbor, MI 48105

NSF/ANSI 44-2016: Residential Cation Exchange Water Softeners
601.3.5 (6.3.5)

NSF/ANSI 58-2016: Reverse Osmosis Drinking Water Treatment Systems
601.3.6 (6.3.6)

NSF/ANSI 140-2015: Sustainability Assessment for Carpet
901.4.1.4 (9.4.1.4)

NSF/ANSI 332-2015: Sustainability Assessment for Resilient Floor Coverings
901.4.1.4 (9.4.1.4)

NSF/ANSI 336-2011: Sustainability Assessment for Commercial Furnishings Fabric
901.4.1.4 (9.4.1.4)

NSF/ANSI 342-2014: Sustainability Assessment for Wallcovering Products
901.4.1.4 (9.4.1.4)

NSF/ANSI 347-2012: Sustainability Assessment for Single Ply Roofing Membranes
901.4.1.4 (9.4.1.4)

NSF/ANSI 350-2017: On-Site Residential and Commercial Water Reuse Systems
601.3.7 (6.3.7)

SCAQMD

South Coast Air Quality Management District
California Air Resources Board
1001 "P" Street; P.O. Box 2815
Sacramento, CA 95812

SCAQMD Rule 1113r, Amended February 5, 2016: Architectural Coatings
801.4.2.2 (8.4.2.2)

SCAQMD Rule 1168, Amended January 7, 2005: Adhesive and Sealant Applications
801.4.2.1 (8.4.2.1)

TCNA

Tile Council of North America
100 Clemson Research Boulevard
Anderson, SC 29625

ANSI A138.1-2011: Standard Specifications for Sustainable Ceramic Tiles, Glass Tiles, and Tile Installation Materials
901.4.1.4 (9.4.1.4)

UL

Underwriters Laboratories Inc.
333 Pfingsten Road
Northbrook, IL 60062

UL 100-2012: Standard for Sustainability for Gypsum Boards and Panels
901.4.1.4 (9.4.1.4)

UL 102-2012: Standard for Sustainability for Door Leafs
901.4.1.4 (9.4.1.4)

NORMATIVE REFERENCES

UL—continued

UL 727-2006: Standard for Oil-Fired Central Furnaces
Appendix B

UL 731-2012: Standard for Oil-Fired Unit Heaters
Appendix B

U.S. Congress

United States Congress
Washington, DC 20515

EPAct 2005 HR6 Public Law 109-58: The Energy Policy Act (EPAct) of 2005
701.4.7.3 (7.4.7.3)

EISA 2007 HR6 Public Law 110-140: The Energy Independence and Security Act of 2007
701.4.7 (7.4.7)

USDA

United States Department of Agriculture
BioPreferred Program
1400 Independence Avenue, SW
Washington, DC 20250

7 CFR Part 3201 Subpart B, (Includes Rounds 1–7) August 29, 2011; Round 8, April 4, 2012; Round 9, November 19, 2012; Round 10, June 11, 2013: Guidelines for Designating Biobased Products for Federal Procurement; Designated Items
901.4.1.3 (9.4.1.3)

USDOE

United States Department of Energy
Energy Information Administration
Washington, DC 20585

10 CFR Part 430, App N: Uniform Test Method for Measuring the Energy Consumption of Furnaces
Appendix B

USEPA

United States Environmental Protection Agency
Ariel Rios Building
1200 Pennsylvania Avenue, NW
Washington, DC 20460

Code of Federal Regulations, Title 40 Part 50 (40 CFR 50), as amended July 1, 2004: National Primary and Secondary Ambient Air Quality Standards
801.3.1.3 (8.3.1.3)

EPA 420-F-07-063, November 2007: Green Vehicle Guide: Consider a SmartWay Vehicle Program—Requirements for Certified Passenger Vehicles
501.3.7 (5.3.7)

EPA 625/R-96/0106, January 1999: Compendium of Methods for the Determination of Toxic Organic Pollutants in Ambient Air, Sections TO-1, TO-11, TO-17
1001.3.1.5 (10.3.1.5)

February 16, 2012: NPDES General Permit for Stormwater Discharges From Construction Activities
1001.3.1.4 (10.3.1.4)

USEPA Method TO-17 (1999): Determination of Volatile Organic Compounds in Ambient Air Using Active Sampling Onto Sorbent Tubes
801.4.2 (8.4.2)

Version 1.0, August 1, 2012: ENERGY STAR Program Requirements for Uninterruptible Power Supplies
701.4.7 (7.4.7)

Version 1.0, August 14, 2009: WaterSense Specification for Flushing Urinals
601.3.2.1 (6.3.2.1)

Version 1.0, March 4, 2010: WaterSense Specification for Showerheads
601.3.2.1 (6.3.2.1)

Version 1.0, October 1, 2007: WaterSense Tank-Type High-Efficiency Lavatory Faucet Specification
601.3.2.1 (6.3.2.1)

NORMATIVE REFERENCES

USEPA—continued

- Version 5.0, May 13, 2016: ENERGY STAR Program Requirements for Set-Top Boxes**
701.4.7 (7.4.7)
- Version 5.0, September 15, 2014: ENERGY STAR Program Requirements for Refrigerators and Freezers**
701.4.7 (7.4.7)
- Version 5.0, September, 15, 2015: ENERGY STAR Program Requirements for ASHPs and Central Air Conditioners**
701.4.7 (7.4.7)
- Version 6.0, April 29, 2015: ENERGY STAR Program Requirements Product Specification for Residential Dishwashers**
601.3.2.2 (6.3.2.2), 701.4.7 (7.4.7)
- Version 6.1, August 12, 2014: ENERGY STAR Program Requirements for Computers**
701.4.7 (7.4.7)
- Version 7.0, May 2016: ENERGY STAR Program Requirements for Displays**
701.4.7 (7.4.7)
- Version 7.0, October 30, 2015: ENERGY STAR Program Requirements for Televisions**
701.4.7 (7.4.7)
- Version 7.1, May 20, 2015: ENERGY STAR Program Requirements for Clothes Washers**
601.3.2.2 (6.3.2.2), 701.4.7 (7.4.7)

WTO

World Trade Organization
Centre William Rappard
Rue de Lausanne 154,
CH-1211 Geneva 21, Switzerland

- WTO TBT-1994: WTO Technical Barriers to Trade (TBT) Agreement Annex 3 Code of Good Practice for the Preparation, Adoption and Application of Standards**
901.4.1.3.1 (9.4.1.3.1)

NORMATIVE APPENDIX A

CLIMATE ZONES AND PRESCRIPTIVE BUILDING ENVELOPE AND DUCT INSULATION TABLES

(This is a normative appendix and is part of this code.)

Tables A101.1 (A-1) through A101.3 (A-3) appear twice in this appendix. The three tables are shown first with I-P units, followed by three tables with SI units.

For *climate zones*, see ANSI/ASHRAE/IES Standard 90.1, Section 5.1.4, and ANSI/ASHRAE Standard 169.

- a. For locations in the United States and its territories, use ANSI/ASHRAE Standard 169, Table B-1, “U.S. States by State and County,” to determine the assigned climate zone and, where required, the assigned climate zone letter. **Informative Note:** Referenced Standard Reproduction Annex ASHRAE Standard 169 (included at the end of this document) contains an extraction of ANSI/ASHRAE Standard 169, Figure B-1, “Climate Zone for United States Counties,” (which is informative for Standards 90.1 and 189.1). ANSI/ASHRAE/IES Standard 90.1 Referenced Standard Reproduction Annex ASHRAE Standard 169 (included at the end of ANSI/ASHRAE/IES Standard 90.1) contains an extraction of ANSI/ASHRAE Standard 169, Table B-1, “U.S. States by State and County.”
- b. For locations in Canada that are listed in ASHRAE Standard 169, Table A-5, “Canada Stations and Climate Zones,” use this table to determine the assigned

climate zone number and, where required, the assigned *climate zone* letter. For locations in other international countries that are listed in ASHRAE Standard 169, Table A-6, “International Stations and Climate Zones,” use this table to determine the required *climate zone* number and, where required, the assigned *climate zone* letter. For all international locations that are not listed either in ASHRAE Standard 169, Table A-5 or Table A-6, use ASHRAE Standard 169, Section A3, “Climate Zone Definitions,” and Table A-3, “Thermal Climate Zone Definitions,” to determine both the *climate zone* number and letter. **Informative Note:** Reference Standard Reproduction Annex ASHRAE Standard 169 (included at the end of this document) contains an extraction of ASHRAE Standard 169, Section A3, “Climate Zone Definitions,” and Table A-3, “Thermal Climate Zone Definitions.” ANSI/ASHRAE/IES Standard 90.1 Referenced Standard Reproduction Annex ASHRAE Standard 169 (included at the end of ANSI/ASHRAE/IES Standard 90.1) contains an extraction of ASHRAE Standard 169, Table A-5, “Canada Stations and Climate Zones,” and Table A-6, “International Stations and Climate Zones.”

TABLE A101.1 (TABLE A-1)
(SUPERSEDES TABLE A2.4.2 IN ANSI/ASHRAE/IES STANDARD 90.1)
SINGLE-RAFTER ROOF REQUIREMENTS (I-P)

CLIMATE ZONE	MINIMUM INSULATION R-VALUE OR MAXIMUM ASSEMBLY U-FACTOR		
	NONRESIDENTIAL	RESIDENTIAL	SEMHEATED
0, 1	R-38 U-0.029	R-38 + R10 ci U-0.022	R-19 U-0.055
2	R-38 + R10 ci U-0.022	R-38 + R10 ci U-0.022	R-19 U-0.055
3, 4, 5	R-38 + R10 ci U-0.022	R-38 + R10 ci U-0.022	R-30 U-0.036
6	R-38 + R10 ci U-0.022	R-38 + R10 ci U-0.022	R-38 U-0.029
7, 8	R-38 + R15 ci U-0.020	R-38 + R15 ci U-0.020	R-38 U-0.029

TABLE A101.2 (TABLE A-2)
(SUPERSEDES TABLE 6.8.2 IN ANSI/ASHRAE/IES STANDARD 90.1)
MINIMUM DUCT INSULATION R-VALUE^a HEATING- AND COOLING-ONLY SUPPLY DUCTS AND RETURN DUCTS (I-P)

CLIMATE ZONE	DUCT LOCATION						
	EXTERIOR	VENTILATED ATTIC	UNVENTED ATTIC ABOVE INSULATED CEILING	UNVENTED ATTIC WITH ROOF INSULATION ^a	UNCONDITIONED SPACE ^b	INDIRECTLY CONDITIONED SPACE ^c	BURIED
Heating-Only Ducts							
0, 1, 2	None	None	None	None	None	None	None
3	R-6	None	None	None	R-6	None	None
4	R-6	None	None	None	R-6	None	None
5	R-8	R-6	None	None	R-6	None	R-6
6	R-8	R-8	R-6	None	R-6	None	R-6
7	R-10	R-8	R-8	None	R-6	None	R-6
8	R-10	R-10	R-8	None	R-8	None	R-8
Cooling-Only Ducts							
0, 1	R-6	R-8	R-10	R-6	R-6	None	R-6
2	R-6	R-8	R-10	R-6	R-6	None	R-6
3	R-6	R-8	R-8	R-6	R-3.5	None	None
4	R-3.5	R-6	R-8	R-3.5	R-3.5	None	None
5, 6	R-3.5	R-3.5	R-6	R-3.5	R-3.5	None	None
7, 8	R-1.9	R-3.5	R-3.5	R-3.5	R-3.5	None	None
Return Ducts							
0 to 8	R-6	R-6	R-6	None	None	None	None

- a. Insulation R-values, measured in (h·ft²·°F)/Btu, are for the insulation as installed and do not include film resistance. The required minimum thicknesses do not consider water vapor transmission and possible surface condensation. Where exterior walls are used as plenum walls, wall insulation shall be as required by the most restrictive condition of this table or Section 701.4.2 (7.4.2). Insulation resistance is measured on a horizontal plane in accordance with ASTM C518 at a mean temperature of 75°F at the installed thickness.
- b. Includes crawlspaces, both ventilated and nonventilated.
- c. Includes return air plenums with or without exposed roofs above.

TABLE A101.3 (TABLE A-3)
(SUPERSEDES TABLE 6.8.2 IN ANSI/ASHRAE/IES STANDARD 90.1)
MINIMUM DUCT INSULATION R-VALUE^a COMBINED HEATING AND COOLING SUPPLY DUCTS AND RETURN DUCTS (I-P)

CLIMATE ZONE	DUCT LOCATION						
	EXTERIOR	VENTILATED ATTIC	UNVENTED ATTIC ABOVE INSULATED CEILING	UNVENTED ATTIC WITH ROOF INSULATION ^a	UNCONDITIONED SPACE ^b	INDIRECTLY CONDITIONED SPACE ^c	BURIED
Supply Ducts							
0, 1	R-8	R-8	R-10	R-6	R-6	None	R-6
2	R-8	R-8	R-8	R-6	R-8	None	R-6
3	R-8	R-8	R-8	R-6	R-8	None	R-6
4	R-8	R-8	R-8	R-6	R-8	None	R-6
5	R-8	R-8	R-8	R-3.5	R-8	None	R-6
6	R-10	R-8	R-8	R-3.5	R-8	None	R-6
7	R-10	R-8	R-8	R-3.5	R-8	None	R-6
8	R-10	R11	R11	R-3.5	R-8	None	R-8
Return Ducts							
0 to 8	R-6	R-6	R-6	None	None	None	None

- a. Insulation R-values, measured in (h·ft²·°F)/Btu, are for the insulation as installed and do not include film resistance. The required minimum thicknesses do not consider water vapor transmission and possible surface condensation. Where exterior walls are used as plenum walls, wall insulation shall be as required by the most restrictive condition of this table or Section 701.4.2 (7.4.2). Insulation resistance is measured on a horizontal plane in accordance with ASTM C518 at a mean temperature of 75°F at the installed thickness.
- b. Includes crawlspaces, both ventilated and non-ventilated.
- c. Includes return air plenums with or without exposed roofs above.

TABLE A101.1 (TABLE A-1)
(SUPERSEDES TABLE A2.4.2 IN ANSI/ASHRAE/IES STANDARD 90.1)
SINGLE-RAFTER ROOF REQUIREMENTS (SI)

CLIMATE ZONE	MINIMUM INSULATION R-VALUE OR MAXIMUM ASSEMBLY U-FACTOR		
	NONRESIDENTIAL	RESIDENTIAL	SEMIHEATED
0, 1	R-6.7 U-0.165	R-6.7 + R-1.8 ci U-0.112	R-3.3 U-0.312
2	R-6.7 + R-1.8 ci U-0.112	R-6.7 + R-1.8 ci U-0.112	R-3.3 U-0.312
3, 4, 5	R-6.7 + R-1.8 ci U-0.112	R-6.7 + R-1.8 ci U-0.112	R-5.3 U-0.204
6	R-6.7 + R-1.8 ci U-0.112	R-6.7 + R-1.8 ci U-0.112	R-6.7 U-0.165
7, 8	R-6.7 + R-2.6 ci U-0.111	R-6.7 + R-2.6 ci U-0.111	R-6.7 U-0.165

TABLE A101.2 (TABLE A-2)
(SUPERSEDES TABLE 6.8.2 IN ANSI/ASHRAE/IES STANDARD 90.1)
MINIMUM DUCT INSULATION R-VALUE^a HEATING- AND COOLING-ONLY SUPPLY DUCTS AND RETURN DUCTS (SI)

CLIMATE ZONE	DUCT LOCATION						
	EXTERIOR	VENTILATED ATTIC	UNVENTED ATTIC ABOVE INSULATED CEILING	UNVENTED ATTIC WITH ROOF INSULATION ^a	UNCONDITIONED SPACE ^b	INDIRECTLY CONDITIONED SPACE ^c	BURIED
Heating-Only Ducts							
0, 1, 2	None	None	None	None	None	None	None
3	R-1.06	None	None	None	R-1.06	None	None
4	R-1.06	None	None	None	R-1.06	None	None
5	R-1.41	R-1.06	None	None	R 1.06	None	R-1.06
6	R-1.41	R-1.41	R-1.06	None	R 1.06	None	R-1.06
7	R-1.76	R-1.41	R-1.41	None	R-1.06	None	R-1.06
8	R-1.76	R-1.76	R-1.41	None	R-1.41	None	R-1.41
Cooling-Only Ducts							
0, 1	R-1.06	R-1.41	R-10	R-1.06	R-1.06	None	R-1.06
2	R-1.06	R-1.41	R-10	R-1.06	R-1.06	None	R-1.06
3	R-1.06	R-1.41	R-1.41	R-1.06	R-0.62	None	None
4	R-0.62	R-1.06	R-1.41	R-0.62	R-0.62	None	None
5, 6	R-0.62	R-0.62	R-1.06	R-0.62	R-0.62	None	None
7, 8	R-1.9	R-0.62	R-0.62	R-0.62	R-0.62	None	None
Return Ducts							
0 to 8	R-1.06	R-1.06	R-1.06	None	None	None	None

- a. Insulation R-values, measured in m²·k/kW, are for the insulation as installed and do not include film resistance. The required minimum thicknesses do not consider water vapor transmission and possible surface condensation. Where exterior *walls* are used as plenum *walls*, *wall* insulation shall be as required by the most restrictive condition of this table or Section 701.4.2 (7.4.2). Insulation resistance measured on a horizontal plane in accordance with ASTM C518 at a mean temperature of 23.8 C at the installed thickness.
- b. Includes crawlspaces, both ventilated and non-ventilated.
- c. Includes return air plenums with or without exposed *roofs* above.

TABLE A101.3 (TABLE A-3)
(SUPERSEDES TABLE 6.8.2 IN ANSI/ASHRAE/IES STANDARD 90.1)
MINIMUM DUCT INSULATION R-VALUE^a COMBINED HEATING AND COOLING SUPPLY DUCTS AND RETURN DUCTS (SI)

CLIMATE ZONE	DUCT LOCATION						
	EXTERIOR	VENTILATED ATTIC	UNVENTED ATTIC ABOVE INSULATED CEILING	UNVENTED ATTIC WITH ROOF INSULATION ^a	UNCONDITIONED SPACE ^b	INDIRECTLY CONDITIONED SPACE ^c	BURIED
Supply Ducts							
0, 1	R-1.41	R-1.41	R-1.76	R-1.06	R-1.06	None	R-1.06
2	R-1.41	R-1.41	R-1.41	R-1.06	R-1.41	None	R-1.06
3	R-1.41	R-1.41	R-1.41	R-1.06	R-1.41	None	R-1.06
4	R-1.41	R-1.41	R-1.41	R-1.06	R-1.41	None	R-1.06
5	R-1.41	R-1.41	R-1.41	R-0.62	R-1.41	None	R-1.06
6	R-1.76	R-1.41	R-1.41	R-0.62	R-1.41	None	R-1.06
7	R-1.76	R-1.41	R-1.41	R-0.62	R-1.41	None	R-1.06
8	R-1.76	R-1.94	R-1.94	R-0.62	R-1.41	None	R-1.41
Return Ducts							
0 to 8	R-1.06	R-1.06	R-1.06	None	None	None	None

- a. Insulation R-values, measured in m²·k/kW, are for the insulation as installed and do not include film resistance. The required minimum thicknesses do not consider water vapor transmission and possible surface condensation. Where exterior *walls* are used as plenum *walls*, *wall* insulation shall be as required by the most restrictive condition of this table or Section 701.4.2 (7.4.2). Insulation resistance measured on a horizontal plane in accordance with ASTM C518 at a mean temperature of 23.8 C at the installed thickness.”
- b. Includes crawlspaces, both ventilated and non-ventilated.
- c. Includes return air plenums with or without exposed *roofs* above.

NORMATIVE APPENDIX B

PRESCRIPTIVE EQUIPMENT EFFICIENCY TABLES FOR THE ALTERNATE REDUCED RENEWABLES AND INCREASED EQUIP- MENT EFFICIENCY APPROACH IN SECTION 701.4.1.1.2 (7.4.1.1.2)

(This is a normative appendix and is part of this code.)

Informative Note: The first 11 tables appear in I-P units and are followed by 11 tables in SI units.

TABLE B101.1 (TABLE B-1)
(SUPERSEDES TABLE 6.8.1-1 IN ANSI/ASHRAE/IES STANDARD 90.1)
ELECTRICALLY OPERATED UNITARY AIR CONDITIONERS AND
CONDENSING UNITS—MINIMUM EFFICIENCY REQUIREMENTS (I-P)

EQUIPMENT TYPE	SIZE CATEGORY	HEATING SECTION TYPE	SUBCATEGORY OR RATING CONDITIONS	MINIMUM EFFICIENCY	TEST PROCEDURE ^a
Air conditioners, air cooled	< 65,000 Btu/h (one phase)	All	Split systems	15.0 SEER 12.5 EER	AHRI 210/240
			Single packaged	15.0 SEER 12.0 EER	
	< 65,000 Btu/h (three phase)	All	Split systems	15.0 SEER 12.5 EER	
			Single packaged	15.0 SEER 12.0 EER	
Through-the-wall, air cooled	< 3 0,000 Btu/h	All	Split systems	12.0 SEER	AHRI 210/240
			Single packaged	12.0 SEER	
Small duct, high velocity, air cooled	< 65,000 Btu/h (one phase)	All	Split systems	12.0 SEER	AHRI 210/240
Small duct, high velocity, air cooled	< 65,000 Btu/h (three phase)	All	Split systems	12.0 SEER	
Air conditioners, air cooled	≥ 65,000 Btu/h and < 135,000 Btu/h	Electric resistance (or none)	Split systems and single package	12.2 EER 14.0 IEER	AHRI 340/360
		All other	Split systems and single package	12.0 EER 13.8 IEER	
	≥ 135,000 Btu/h and < 240,000 Btu/h	Electric resistance (or none)	Split systems and single package	12.2 EER 13.2 IEER	
		All other	Split systems and single package	12.0 EER 13.0 IEER	
	≥ 240,000 Btu/h and < 760,000 Btu/h	Electric resistance (or none)	Split systems and single package	10.8 EER 12.3 IEER	
		All other	Split systems and single package	10.6 EER 12.1 IEER	
	≥ 760,000 Btu/h	Electric resistance (or none)	Split systems and single package	10.4 EER 11.6 IEER	
		All other	Split systems and single package	10.2 EER 11.4 IEER	

a. Chapter 11 (Section 11) contains a details on the referenced test procedures, including year and version of the test procedure.

(continued)

TABLE B101.1 (TABLE B-1)
(SUPERSEDES TABLE 6.8.1-1 IN ANSI/ASHRAE/IES STANDARD 90.1)
ELECTRICALLY OPERATED UNITARY AIR CONDITIONERS AND
CONDENSING UNITS—MINIMUM EFFICIENCY REQUIREMENTS (I-P) (Continued)

EQUIPMENT TYPE	SIZE CATEGORY	HEATING SECTION TYPE	SUBCATEGORY OR RATING CONDITIONS	MINIMUM EFFICIENCY	TEST PROCEDURE ^a	
Air conditioners, water cooled	< 65,000 Btu/h	All	Split systems and single package	14.0 EER 15.3 IEER	AHRI 210/240	
	≥ 65,000 Btu/h and < 135,000 Btu/h	Electric resistance (or none)	Split systems and single package	14.0 EER 15.3 IEER	AHRI 340/360	
		All other	Split systems and single package	13.8 EER 15.1 IEER		
	≥ 135,000 Btu/h and < 240,000 Btu/h	Electric resistance (or none)	Split systems and single package	14.0 EER 14.8 IEER		
		All other	Split systems and single package	13.8 EER 14.6 IEER		
	≥ 240,000 Btu/h and < 760,000 Btu/h	Electric resistance (or none)	Split systems and single package	14.0 EER 14.8 IEER		
		All other	Split systems and single package	13.8 EER 14.6 IEER		
	≥ 760,000 Btu/h	Electric resistance (or none)	Split systems and single package	14.0 EER 14.8 IEER		
		All other	Split systems and single package	13.8 EER 14.6 IEER		
	Air conditioners, evaporatively cooled	< 65,000 Btu/h	All	Split systems and single package		14.0 EER 15.3 IEER
≥ 65,000 Btu/h and < 135,000 Btu/h		Electric resistance (or none)	Split systems and single package	14.0 EER 15.3 IEER		AHRI 340/360
		All other	Split systems and single package	13.8 EER 15.1 IEER		
≥ 135,000 Btu/h and < 240,000 Btu/h		Electric resistance (or none)	Split systems and single package	14.0 EER 14.8 IEER		
		All other	Split systems and single package	13.8 EER 14.6 IEER		
≥ 240,000 Btu/h and < 760,000 Btu/h		Electric resistance (or none)	Split systems and single package	14.0 EER 14.8 IEER		
		All other	Split systems and single package	13.8 EER 14.6 IEER		
≥ 760,000 Btu/h		Electric resistance (or none)	Split systems and single package	14.0 EER 14.8 IEER		
		All other	Split systems and single package	13.8 EER 14.6 IEER		
Condensing units, air cooled		≥ 135,000 Btu/h			Not applicable match with indoor coil	
Condensing, water or evaporatively cooled	≥ 135,000 Btu/h			Not applicable match with indoor coil		

a. Chapter 11 (Section 11) contains a details on the referenced test procedures, including year and version of the test procedure.

(continued)

TABLE B101.2 (TABLE B-2)
(SUPERSEDES TABLE 6.8.1-2 IN ANSI/ASHRAE/IES STANDARD 90.1)
ELECTRICALLY OPERATED UNITARY AND APPLIED HEAT PUMPS—MINIMUM EFFICIENCY REQUIREMENTS (I-P)

EQUIPMENT TYPE	SIZE CATEGORY	HEATING SECTION TYPE	SUBCATEGORY OR RATING CONDITIONS	MINIMUM EFFICIENCY	TEST PROCEDURE ^a
Air conditioners, air cooled (cooling mode)	< 65,000 Btu/h (one phase)	All	Split systems	15.0 SEER 12.5 EER	AHRI 210/240
			Single packaged	15.0 SEER 12.0 EER	
	< 65,000 Btu/h (three phase)	All	Split systems	15.0 SEER 12.5 EER	
			Single packaged	15.0 SEER 12.0 EER	
Through-the-wall, air cooled (cooling mode)	< 30,000 Btu/h	All	Split systems	12.0 SEER	AHRI 210/240
			Single packaged	12.0 SEER	
Small duct high velocity, air cooled (cooling mode)	< 65,000 Btu/h (one phase)	All	Split systems	12.0 SEER	AHRI 210/240
	< 65,000 Btu/h (three phase)	All	Split systems	12.0 SEER	
Air conditioners, air cooled (cooling mode)	≥ 65,000 Btu/h and < 135,000 Btu/h	Electric resistance (or none)	Split systems and single package	11.3 EER 12.3 IEER	AHRI 340/360
		All other	Split systems and single package	11.1 EER 12.1 IEER	
	≥ 135,000 Btu/h and < 240,000 Btu/h	Electric resistance (or none)	Split systems and single package	10.9 EER 11.9 IEER	
		All other	Split systems and single package	10.7 EER 11.7 IEER	
	≥ 240,000 Btu/h	Electric resistance (or none)	Split systems and single package	10.3 EER 10.9 IEER	
		All other	Split systems and single package	10.1 EER 10.7 IEER	
Water-to-air water loop (cooling mode)	< 17,000 Btu/h	All	86°F entering water	14.0 EER	ISO-13256-1
	≥ 17,000 Btu/h and < 65,000 Btu/h	All	86°F entering water	14.0 EER	
	> 65,000 Btu/h and < 135,000 Btu/h	All	86°F entering water	14.0 EER	
Water-to-air ground water (cooling mode)	< 135,000 Btu/h	All	59°F entering water	18.0 EER	ISO-13256-1
Water-to-air ground loop (cooling mode)	< 135,000 Btu/h	All	77°F entering water	14.1 EER	
Water-to-water water loop (cooling mode)	< 135,000 Btu/h	All	86°F entering water	10.6 EER	ISO-13256-2
Water-to-water groundwater (cooling mode)	< 135,000 Btu/h	All	59°F entering water	16.3 EER	
Brine-to-water ground loop (cooling mode)	< 135,000 Btu/h	All	77°F entering water	12.1 EER	

a. Chapter 11 (Section 11) contains details on the referenced test procedures, including year and version of the test procedure.

(continued)

TABLE B101.2 (TABLE B-2)
(SUPERSEDES TABLE 6.8.1-2 IN ANSI/ASHRAE/IES STANDARD 90.1)
ELECTRICALLY OPERATED UNITARY AND APPLIED HEAT PUMPS—MINIMUM EFFICIENCY REQUIREMENTS (I-P) (Continued)

EQUIPMENT TYPE	SIZE CATEGORY	HEATING SECTION TYPE	SUBCATEGORY OR RATING CONDITIONS	MINIMUM EFFICIENCY	TEST PROCEDURE ^a
Air conditioners, air cooled (heating mode)	< 65,000 Btu/h (cooling capacity) (one phase)	All	Split systems	9.00 HSPF	AHRI 210/240
			Single packaged	8.50 HSPF	
	< 65,000 Btu/h (cooling capacity) (three phase)	All	Split systems	9.00 HSPF	
			Single packaged	8.50 HSPF	
Through-the-wall, air cooled (heating mode)	< 30,000 Btu/h (cooling capacity)	All	Split systems	7.40 HSPF	
			Single packaged	7.40 HSPF	
Small-duct high velocity, air cooled (heating mode)	< 65,000 Btu/h (cooling capacity) (one phase)	All	Split systems	7.20 HSPF	AHRI 210/240
	< 65,000 Btu/h (cooling capacity) (three phase)	All	Split systems	7.20 HSPF	
Air cooled (heating mode)	≥ 65,000 Btu/h and < 135,000 Btu/h (cooling capacity)		47°F db/43°F wb outdoor air	3.40 COP _H	AHRI 340/360
			17°F db/15°F wb outdoor air	2.40 COP _H	
	≥ 135,000 Btu/h (cooling capacity)		47°F db/43°F wb outdoor air	3.20 COP _H	
			17°F db/15°F wb outdoor air	2.10 COP _H	
Water-to-air water loop (heating mode)	< 135,000 Btu/h (cooling capacity)		68°F entering water	4.60 COP _H	ISO-13256-1
Water-to-air groundwater (heating mode)	< 135,000 Btu/h (cooling capacity)		50°F entering water	3.70 COP _H	
Brine-to-air ground loop (heating mode)	< 135,000 Btu/h (cooling capacity)		32°F entering fluid	3.20 COP _H	
Water-to-water water loop (heating mode)	< 135,000 Btu/h (cooling capacity)		68°F entering water	3.70 COP _H	ISO-13256-2
Water-to-water groundwater (heating mode)	< 135,000 Btu/h (cooling capacity)		50°F entering water	3.10 COP _H	
Brine-to-water ground loop (heating mode)	< 135,000 Btu/h (cooling capacity)		32°F entering fluid	2.50 COP _H	

a. Chapter 11 (Section 11) contains details on the referenced test procedures, including year and version of the test procedure.

TABLE B101.3 (TABLE B-3)
(SUPERSEDES TABLE 6.8.1-4 IN ANSI/ASHRAE/IES STANDARD 90.1)
ELECTRICALLY OPERATED SINGLE-PACKAGED VERTICAL AIR CONDITIONERS AND SINGLE-PACKAGED VERTICAL HEAT PUMPS AIR-CONDITIONER HEAT PUMPS—MINIMUM EFFICIENCY REQUIREMENTS (I-P)

EQUIPMENT TYPE	SIZE CATEGORY	SUBCATEGORY OR RATING CONDITION	MINIMUM EFFICIENCY	TEST PROCEDURE ^a
PTAC (cooling mode) standard size	All capacities	95°F db <i>outdoor air</i>	14.4 – (0.300 × Cap/1000) ^c EER	AHRI 310/380
PTAC (cooling mode) nonstandard size ^b	All capacities	95°F db <i>outdoor air</i>	10.9 – (0.213 × Cap/1000) ^c EER	AHRI 310/380
PTHP (cooling mode) standard size	All capacities	95°F db <i>outdoor air</i>	14.4 – (0.300 × Cap/1000) ^c EER	ARI 310/380
PTHP (cooling mode) nonstandard size ^b	< 7000 Btu/h	95°F db <i>outdoor air</i>	10.8 – (0.213 × Cap/1000) ^c EER	ARI 310/380
PTHP (heating mode) new constructions	All capacities	47°F db/43°F wb <i>outdoor air</i>	3.7 – (0.052 × Cap/1000) ^c COP _H	ARI 310/380
PTHP (heating mode) nonstandard size ^b	All capacities	47°F db/43°F wb <i>outdoor air</i>	2.9 – (0.026 × Cap/1000) ^c COP _H	ARI 310/380

- a. Chapter 11 (Section 11) contains a complete specification of the referenced test procedures, including year version of the test procedure.
- b. Replacement units shall be factory labeled as follows: “MANUFACTURED FOR REPLACEMENT APPLICATIONS ONLY; NOT TO BE INSTALLED IN NEW CONSTRUCTION PROJECTS.” Replacement efficiencies apply only to units with existing sleeves less than 16 in. high and less than 42 in. wide and having a cross-sectional area less than 670 in.².
- c. “Cap” means the rated cooling capacity of the product in Btu/h. If the unit’s capacity is less than 7000 Btu/h, use 7000 Btu/h in the calculation. If the unit’s capacity is greater than 15,000 Btu/h, use 15,000 Btu/h in the calculation.

TABLE B101.4 (TABLE B-4)
(SUPERSEDES TABLE 6.8.1-4 IN ANSI/ASHRAE/IES STANDARD 90.1)
SINGLE-PACKAGED VERTICAL AIR CONDITIONERS, SINGLE-PACKAGED VERTICAL HEAT PUMPS, ROOM AIR CONDITIONERS, AND ROOM AIR-CONDITIONER HEAT PUMPS—MINIMUM EFFICIENCY REQUIREMENTS (I-P)

EQUIPMENT TYPE	SIZE CATEGORY (INPUT)	SUBCATEGORY OR RATING CONDITION	MINIMUM EFFICIENCY BASE	MINIMUM EFFICIENCY CONNECTED ^b	TEST PROCEDURE ^a
SPVAC (cooling mode)	< 65,000 Btu/h	95°F db/75°F wb <i>outdoor air</i>	14.0 SEER		AHRI 210/240
	≥ 65,000 Btu/h and < 135,000 Btu/h	95°F db/75°F wb <i>outdoor air</i>	11.2 EER 12.9 IEER		AHRI 340/360
	≥ 135,000 Btu/h and < 240,000 Btu/h	95°F db/75°F wb <i>outdoor air</i>	11.0 EER 12.4 IEER		
SPVHP (cooling mode)	< 65,000 Btu/h	95°F db/75°F wb <i>outdoor air</i>	14.0 SEER		AHRI 210/240
	≥ 65,000 Btu/h and < 135,000 Btu/h	95°F db/75°F wb <i>outdoor air</i>	11.0 EER 12.2 IEER		AHRI 340/360
	≥ 135,000 Btu/h and < 240,000 Btu/h	95°F db/75°F wb <i>outdoor air</i>	10.6 EER 11.6 IEER		
SPVHP (heating mode)	< 65,000 Btu/h	47°F db/43°F wb <i>outdoor air</i>	8.0 HSPF		AHRI 210/240
	≥ 65,000 Btu/h and < 135,000 Btu/h	47°F db/43°F wb <i>outdoor air</i>	3.3 COP _H		AHRI 340/360
	≥ 135,000 Btu/h and < 240,000 Btu/h	47°F db/43°F wb <i>outdoor air</i>	3.2 COP _H		
Room air conditioners, with louvered sides	< 6,000 Btu/h		12.1 CEER	11.5 CEER	ANSI/AHAM RAC-1
	≥ 6,000 Btu/h and < 8,000 Btu/h		12.1 CEER	11.5 CEER	
	≥ 8,000 Btu/h and < 14,000 Btu/h		12.0 CEER	11.5 CEER	
	≥ 14,000 Btu/h and < 20,000 Btu/h		11.8 CEER	11.2 CEER	
	≥ 20,000 Btu/h and < 28,000 Btu/h		10.3 CEER	9.8 CEER	
	≥ 28,000 Btu/h		9.9 CEER	9.4 CEER	
Room air conditioners, without louvered sides	< 6,000 Btu/h		11.0 CEER	10.5 CEER	
	≥ 6,000 Btu/h and < 8,000 Btu/h		11.0 CEER	10.5 CEER	
	≥ 8,000 Btu/h and < 11,000 Btu/h		10.6 CEER	10.1 CEER	
	≥ 11,000 Btu/h and < 14,000 Btu/h		10.5 CEER	10.0 CEER	
	≥ 14,000 Btu/h and < 20,000 Btu/h		10.2 CEER	9.7 CEER	
	≥ 20,000 Btu/h		10.3 CEER	9.8 CEER	
Room air conditioner heat pump, with louvered sides	< 20,000 Btu/h		10.8 CEER	10.3 CEER	
	≥ 20,000 Btu/h		10.2 CEER	9.7 CEER	
Room air conditioner heat pump, without louvered sides	< 14,000 Btu/h		10.2 CEER	9.7 CEER	
	≥ 14,000 Btu/h		9.6 CEER	9.1 CEER	
Room air conditioner, casement only	All capacities		10.5 CEER	10.0 CEER	
Room air conditioner, casement-slider	All capacities		11.4 CEER	10.8 CEER	

a. Chapter 11 (Section 11) contains details for the referenced test procedure, including the referenced year version of the test procedure.
b. Connected room air conditioners that are connected to utility programs are allowed a lower CEER value but must be in compliance with and certified per EnergyStar version 4.0 requirements for connected equipment.

TABLE B101.5 (TABLE B-5)
(SUPERSEDES TABLE 6.8.1-5 IN ANSI/ASHRAE/IES STANDARD 90.1)
WARM-AIR FURNACES AND COMBINATION WARM-AIR FURNACES/AIR-CONDITIONING UNITS, WARM-AIR DUCT FURNACES, AND UNIT HEATERS—MINIMUM EFFICIENCY REQUIREMENTS (I-P)

EQUIPMENT TYPE	SIZE CATEGORY (INPUT)	SUBCATEGORY OR RATING CONDITION	MINIMUM EFFICIENCY	TEST PROCEDURE ^a
Warm-air furnace, gas fired (weatherized)	< 225,000 Btu/h	Maximum capacity ^c	81% AFUE ^b	DOE 10 CFR Part 430 or Section 2.39, Thermal Efficiency, ANSI Z21.47
	≥ 225,000 Btu/h		80% E_t ^d	Section 2.39, Thermal Efficiency, ANSI Z21.47
Warm-air furnace, gas fired (nonweatherized)	< 225,000 Btu/h	Maximum capacity ^c	90% AFUE or 92% E_t ^{b,d}	DOE 10 CFR Part 430 or Section 2.39, Thermal Efficiency, ANSI Z21.47
	≥ 225,000 Btu/h		92% E_t ^d	Section 2.39, Thermal Efficiency, ANSI Z21.47
Warm-air furnace, oil fired (weatherized)	< 225,000 Btu/h	Maximum capacity ^c	78% AFUE ^{b,d}	DOE 10 CFR Part 430 or Section 42, Combustion, UL 727
	> 225,000 Btu/h		81% E_t ^d	Section 42, Combustion, UL 727
Warm-air furnaces, oil fired (nonweatherized)	< 225,000 Btu/h	Maximum capacity ^c	85% AFUE or 87% E_t ^{b,d}	DOE 10 CFR Part 430 or Section 42, Combustion, UL 727
	≥ 225,000 Btu/h		87% E_t ^d	Section 42, Combustion, UL 727
Warm-air duct furnace, gas fired (weatherized)	All capacities	Maximum capacity ^c	80% E_c ^e	Section 2.10, Efficiency, ANSI Z83.8
Warm-air duct furnace, gas fired (nonweatherized)	All capacities	Maximum capacity ^c	90% E_c ^e	Section 2.10, Efficiency, ANSI Z83.8
Warm-air unit heater, gas fired (nonweatherized)	All capacities	Maximum capacity ^c	80% E_c ^{e,f}	Section 2.10, Efficiency, ANSI Z83.8
Warm-air unit heater, oil fired (weatherized)	All capacities	Maximum capacity ^c	90% E_c ^{e,f}	Section 40, Combustion, UL 731

- a. Chapter 11 (Section 11) contains a complete specification of the referenced test procedure, including the referenced year version of the test procedure.
- b. Combination units not covered by the U.S. Department of Energy Code of Federal Regulations 10 CFR 430 (three-phase power or cooling capacity greater than or equal to 65,000 Btu/h) may comply with either rating.
- c. Compliance of multiple firing rate units shall be at the maximum firing rate.
- d. E_t = thermal efficiency. Units must also include an interrupted or intermittent ignition device (IID), have jacket losses not exceeding 0.75% of the input rating, and have either power venting or a flue damper. A vent damper is an acceptable alternative to a flue damper for those furnaces where combustion air is drawn from the conditioned space.
- e. E_c = combustion efficiency (100% less flue losses). See test procedure for detailed discussion.
- f. As of August 8, 2008, according to the Energy Policy Act of 2005, units must also include an interrupted or intermittent ignition device (IID) and have either power venting or an automatic flue damper.

**TABLE B101.6 (TABLE B-6)
(SUPERSEDES TABLE 6.8.1-6 IN ANSI/ASHRAE/IES STANDARD 90.1)
GAS- AND OIL-FIRED BOILERS—MINIMUM EFFICIENCY REQUIREMENTS (I-P)**

EQUIPMENT TYPE ^a	SUBCATEGORY OR RATING CONDITION	SIZE CATEGORY (INPUT)	MINIMUM EFFICIENCY ^{b,c}	TEST PROCEDURE ^g
Boilers, hot water	Gas fired	< 300,000 Btu/h ^{h,i}	89% AFUE ^{E,h}	10 CFR Part 430
		≥ 300,000 Btu/h and ≤ 2,500,000 Btu/h ^d	89% E_t^f	10 CFR Part 431
		> 2,500,000 Btu/h ^a	91% E_c^f	
	Oil fired ^e	< 300,000 Btu/h	89% AFUE ^f	10 CFR Part 430
		≥ 300,000 Btu/h and ≤ 2,500,000 Btu/h ^d	85% E_t^f	10 CFR Part 431
		> 2,500,000 Btu/h ^a	86% E_c^f	
Boilers, steam	Gas fired	< 300,000 Btu/h ⁱ	80% AFUE	10 CFR Part 430
	Gas fired all except natural draft	≥ 300,000 Btu/h and ≤ 2,500,000 Btu/h ^d	79% E_t	10 CFR Part 431
		> 2,500,000 Btu/h ^a	79% E_t	
	Gas fired natural draft	≥ 300,000 Btu/h and ≤ 2,500,000 Btu/h ^d	77% E_t	
		> 2,500,000 Btu/h ^a	77% E_t	
	Oil fired ^e	< 300,000 Btu/h	82% AFUE	10 CFR Part 430
		≥ 300,000 Btu/h and ≤ 2,500,000 Btu/h ^d	81% E_t	10 CFR Part 431
		> 2,500,000 Btu/h ^a	81% E_t	

- a. These requirements apply to boilers with rated input of 8,000,000 Btu/h or less that are not packaged boilers and to all packaged boilers. Minimum efficiency requirements for boilers cover all capacities of packaged boilers.
- b. E_c = thermal efficiency (100% less flue losses). See reference document for detailed information.
- c. E_t = thermal efficiency. See reference document for detailed information.
- d. Maximum capacity—minimum and maximum ratings as provided for and allowed by the unit's controls.
- e. Includes oil fired (residual).
- f. Systems shall be designed with lower operating return hot-water temperatures (<130°F) and use hot-water reset to take advantage of the much higher efficiencies of condensing boilers.
- g. Chapter 11 (Section 11) contains details for the referenced test procedure, including the referenced year version of the test procedure.
- h. A boiler not equipped with a tankless domestic water-heating coil shall be equipped with an *automatic* means for adjusting the temperature of the water such that an incremental change in inferred heat load produces a corresponding incremental change in the temperature of the water supplied.
- i. Boilers shall not be equipped with a continuous pilot ignition system.

TABLE B101.7 (TABLE B-7)
(SUPERSEDES TABLE 6.8.1-7 IN ANSI/ASHRAE/IES STANDARD 90.1)
PERFORMANCE REQUIREMENTS FOR HEAT REJECTION EQUIPMENT—MINIMUM EFFICIENCY REQUIREMENTS (I-P)

EQUIPMENT TYPE	TOTAL SYSTEM HEAT REJECTION CAPACITY AT RATED CONDITIONS	SUBCATEGORY OR RATING CONDITION ^a	PERFORMANCE REQUIRED ^{a,b,c,d,e,f,i}	TEST PROCEDURE ^b
Propeller or axial fan open-circuit cooling towers	All	95°F entering water 85°F leaving water 75°F entering wb	≥ 42.1 gpm/hp	CTI ATC-105 and CTI STD-201RS
Centrifugal fan open-circuit cooling towers	All	95°F entering water 85°F leaving water 75°F entering wb	≥ 22.0 gpm/hp	CTI ATC-105 and CTI STD-201RS
Propeller or axial fan closed-circuit cooling towers	All	102°F entering water 90°F leaving water 75°F entering wb	≥ 16.1 gpm/hp	CTI ATC-105S and CTI STD-201RS
Centrifugal fan closed-circuit cooling towers	All	102°F entering water 90°F leaving water 75°F entering wb	≥ 8.0 gpm/hp	CTI ATC-105S and CTI STD-201RS
Propeller or axial fan evaporative condensers	All	Ammonia test fluid 140°F entering gas temperature 96.3°F condensing temperature 75°F entering wb	≥ 134,000 Btu/h·hp	CTI ATC-106
Centrifugal fan evaporative condensers	All	Ammonia test fluid 140°F entering gas temperature 96.3°F condensing temperature 75°F entering wb	≥ 110,000 Btu/h·hp	CTI ATC-106
Propeller or axial fan evaporative condensers	All	R-507A test fluid 165°F entering gas temperature 105°F condensing temperature 75°F entering wb	≥ 157,000 Btu/h·hp	CTI ATC-106
Centrifugal fan evaporative condensers	All	R-507A test fluid 165°F entering gas temperature 105°F condensing temperature 75°F entering wb	≥ 135,000 Btu/h·hp	CTI ATC-106
Air-cooled condensers	All	190°F entering gas temperature 125°F condensing temperature 15°F subcooling 95°F entering wb	≥ 176,000 Btu/h·hp	AHRI 460

- a. For purposes of this table, *open-circuit cooling tower performance* is defined as the water flow rating of the tower at the thermal rating condition listed in Table B101.7 (B-7) divided by the fan motor nameplate power.
- b. For purposes of this table, *closed-circuit cooling tower performance* is defined as the process water flow rating of the tower at the thermal rating condition listed in Table B101.7 (B-7) divided by the sum of the fan motor nameplate power and the integral spray pump motor nameplate power.
- c. For purposes of this table, *evaporative condenser performance* is defined as the heat rejected at the specified rating condition in the table divided by the sum of the fan motor nameplate power and the integral spray pump nameplate power.
- d. For purposes of this table, *air-cooled condenser performance* is defined as the heat rejected from the refrigerant divided by the fan motor nameplate power.
- e. The efficiencies and test procedures for both *open-* and *closed-circuit cooling towers* are not applicable to hybrid cooling towers that contain a combination of separate wet and dry heat exchange sections. The certification requirements do not apply to field erected cooling towers.
- f. All cooling towers, closed-circuit coolers, evaporative condensers, and air-cooled condensers shall comply with the minimum efficiency listed in the table for that specific type of equipment with the capacity effect of any project specific accessories and/or options included with the equipment.
- g. Requirements for evaporative condensers are listed with ammonia (R-717) and R-507A as test fluids in the table. Evaporative condensers intended for use with halocarbon refrigerants other than R-507A must meet the minimum efficiency requirements listed for R-507A as the test fluid.
- h. Informative Appendix G contains information on the referenced test procedures.
- i. Not applicable for air-cooled condensers applied to condenserless chillers. The air-cooled condenser and condenserless chiller shall comply with the requirements for air-cooled chillers as defined in ANSI/ASHRAE/IES Standard 90.1, Table 6.8.1-3.

TABLE B101.8 (TABLE B-8)
(SUPERSEDES TABLE 7.8 IN ANSI/ASHRAE/IES STANDARD 90.1)
PERFORMANCE REQUIREMENTS FOR SERVICE WATER HEATING EQUIPMENT (I-P)

EQUIPMENT TYPE	SIZE CATEGORY (INPUT)	RATED STORAGE VOLUME AND INPUT RATING (IF APPLICABLE)	DRAW PATTERN	PERFORMANCE REQUIRED ^a	TEST PROCEDURE ^b
Electric table-top water heaters ^c	≤ 12 kW	≥ 20 gal and ≤ 120 gal	Very small	UEF ≥ 0.6323 – 0.0058 <i>V</i>	DOE 10 CFR Part 430
			Low	UEF ≥ 0.9188 – 0.0031 <i>V</i>	
			Medium	UEF ≥ 0.9577 – 0.0023 <i>V</i>	
			High	UEF ≥ 0.9844 – 0.0016 <i>V</i>	
Electric resistance storage water heaters		≥ 20 gal and ≤ 55 gal	Very small	UEF ≥ 0.8808 – 0.0008 <i>V</i>	DOE 10 CFR Part 430
			Low	UEF ≥ 0.9254 – 0.0003 <i>V</i>	
			Medium	UEF ≥ 0.9307 – 0.0002 <i>V</i>	
		High	UEF ≥ 0.9349 – 0.0001 <i>V</i>		
		> 55 gal		Must use heat-pump water heater	
Electric resistance grid-enabled water heaters		> 75 gal	Very small	UEF ≥ 1.0136 – 0.0028 <i>V</i>	DOE 10 CFR Part 430
			Low	UEF ≥ 0.09984 – 0.0014 <i>V</i>	
			Medium	UEF ≥ 0.9853 – 0.0010 <i>V</i>	
			High	UEF ≥ 0.9720 – 0.0007 <i>V</i>	
Heat-pump water heaters		≤ 55 gal		EF ≥ 2.00, FHR ≥ 50 gal	DOE 10 CFR Part 430
		> 55 gal		EF ≥ 2.20, FHR ≥ 50 gal	
Gas-fired storage water heaters	≤ 75,000 Btu/h	≤ 55 gal		EF ≥ 0.67, FHR ≥ 67 gal	DOE 10 CFR Part 430
	> 75,000 Btu/h	> 55 gal		EF ≥ 0.77, FHR ≥ 67 gal	
Gas instantaneous water heaters	> 50,000 Btu/h and < 200,000 Btu/h ^d	≥ 4,000 (Btu/h)/gal and < 2 gal		EF ≥ 0.90 and GPM ≥ 2.5 over a 77°F rise	DOE 10 CFR Part 430
	≥ 75,000 Btu/h ^c	≤ 140 gal and ≥ 4,000 (Btu/h)/gal		$E_t ≥ 0.94$ or $EF ≥ 0.93$ $SL = 0.84 × (Q/800 + 110√V)$, Btu/h	ANSI Z21.10.3
Oil storage water heaters	≤ 105,000 Btu/h	≤ 50 gal	Very small	EF = 0.2509 – 0.0012 <i>V</i>	DOE 10 CFR Part 430
			Low	EF = 0.5330 – 0.0016 <i>V</i>	
			Medium	EF = 0.6078 – 0.0016 <i>V</i>	
			High	EF = 0.6815 – 0.0014 <i>V</i>	
	> 105,000 Btu/h	< 4,000 (Btu/h)/gal		$E_t ≥ 80%$ and $SL ≤ (Q/800 + 110√V)$, Btu/h	ANSI Z21.10.3
Oil instantaneous water heaters	≤ 210,000 Btu/h	≤ 50 gal		EF ≥ 0.59 – 0.0019 <i>V</i>	DOE 10 CFR Part 430
	> 210,000 Btu/h	≥ 4,000 (Btu/h)/gal and < 10 gal		$E_t ≥ 80%$	ANSI Z21.10.3
	> 210,000 Btu/h	≥ 4,000 (Btu/h)/gal and ≥ 10 gal		$E_t ≥ 78%$ and $SL ≤ (Q/800 + 110√V)$, Btu/h	
Solar water heater		Electric backup		SEF ≥ 1.8	ANSI Z21.10.3
		Gas backup		SEF ≥ 1.2	
Hot-water supply boilers, gas and oil	> 300,000 Btu/h and ≤ 12,500,000 Btu/h	≥ 4,000 (Btu/h)/gal and < 10 gal		$E_t ≥ 80%$	ANSI Z21.10.3
Hot-water supply boilers, gas		≥ 4,000 (Btu/h)/gal and ≥ 10 gal		$E_t ≥ 80%$ $SL ≤ (Q/800 + 110√V)$, Btu/h	ANSI Z21.10.3

- a. Energy factor (EF) and thermal efficiency (E_t) are minimum requirements, while standby loss (SL) is maximum Btu/h based on a 70°F temperature difference between stored water and ambient requirements. In the EF equation, V is the rated volume in gallons. In the SL equation, V is the rated volume in gallons and Q is the nameplate input rate in Btu/h.
- b. Chapter 11 (Section 11) contains details on the referenced test procedures, including the year/version of the referenced test procedure.
- c. Section G.1 is titled “Test Method for Measuring Thermal Efficiency,” and Section G.2 is titled “Test Method for Measuring Standby Loss.”
- d. UEF is the Uniform Energy Factor and is a dimensionless number that is calculated per DOE 10 CFR Part 430 test procedures.

(continued)

TABLE B101.8 (TABLE B-8)
(SUPERSEDES TABLE 7.8 IN ANSI/ASHRAE/IES STANDARD 90.1)
PERFORMANCE REQUIREMENTS FOR SERVICE WATER HEATING EQUIPMENT (I-P) (Continued)

EQUIPMENT TYPE	SIZE CATEGORY (INPUT)	RATED STORAGE VOLUME AND INPUT RATING (IF APPLICABLE)	DRAW PATTERN	PERFORMANCE REQUIRED ^a	TEST PROCEDURE ^b
Hot-water supply boilers, oil		≥ 4,000 (Btu/h)/gal and ≥ 10 gal		$E_t \geq 78\%$ $SL \leq (Q/800 + 110\sqrt{V}), \text{ Btu/h}$	
Pool heaters, gas	All sizes			$E_t \geq 82\%$	ASHRAE 146
Pool heaters, oil	All sizes			$E_t \geq 78\%$	ASHRAE 146
Heat-pump pool heaters	All sizes	50°F db 44.2°F wb outdoor air 80.0°F entering water		≥ 4.0 COP	AHRI 1180
Unfired storage tanks	All sizes			≥ R-12.5	None

- a. Energy factor (EF) and thermal efficiency (E_t) are minimum requirements, while standby loss (SL) is maximum Btu/h based on a 70°F temperature difference between stored water and ambient requirements. In the EF equation, V is the rated volume in gallons. In the SL equation, V is the rated volume in gallons and Q is the nameplate input rate in Btu/h.
- b. Chapter 11 (Section 11) contains details on the referenced test procedures, including the year/version of the referenced test procedure.
- c. Section G.1 is titled “Test Method for Measuring Thermal Efficiency,” and Section G.2 is titled “Test Method for Measuring Standby Loss.”
- d. UEF is the Uniform Energy Factor and is a dimensionless number that is calculated per DOE 10 CFR Part 430 test procedures.

TABLE B101.9 (TABLE B-9)
COMMERCIAL CLOTHES WASHERS (I-P)

PRODUCT	MEF ^a	WF ^b , gal/ft ³
All commercial clothes washers	1.72	4.0

- a. MEF = modified energy factor, a combination of energy factor and remaining moisture content. MEF measures energy consumption of the total laundry cycle (washing and drying). It indicates how many cubic feet of laundry can be washed and dried with one kWh of electricity; the higher the number, the greater the efficiency.
- b. WF = water factor (in gal/ft³).

TABLE B101.10 (TABLE B-10)
(SUPERSEDES TABLE 6.8.1-9 IN ANSI/ASHRAE/IES STANDARD 90.1)
ELECTRICALLY OPERATED VARIABLE-REFRIGERANT-FLOW (VRF) AIR CONDITIONERS—MINIMUM EFFICIENCY REQUIREMENTS (I-P)

EQUIPMENT TYPE	SIZE CATEGORY	HEATING SECTION TYPE	SUBCATEGORY OR RATING CONDITION	MINIMUM EFFICIENCY	TEST PROCEDURE ^a
VRF air conditioners, air cooled	< 65,000 Btu/h	All	VRF multisplit system	15.0 SEER 12.5 EER	AHRI 1230
	≥ 65,000 Btu/h and < 135,000 Btu/h	Electric resistance (or none)	VRF multisplit system	11.7 EER 14.9 IEER	
	≥ 135,000 Btu/h and < 240,000 Btu/h	Electric resistance (or none)	VRF multisplit system	11.7 EER 14.4 IEER	
	≥ 240,000 Btu/h	Electric resistance (or none)	VRF multisplit system	10.5 EER 13.0 IEER	

- a. Chapter 11 (Section 11) contains details for the referenced test procedure, including year version of the test procedure.

TABLE B101.11 (TABLE B-11)
(SUPERSEDES TABLE 6.8.1-10 IN ANSI/ASHRAE/IES STANDARD 90.1)
ELECTRICALLY OPERATED VARIABLE-REFRIGERANT-FLOW AND APPLIED
HEAT PUMP—MINIMUM EFFICIENCY REQUIREMENTS (I-P)

EQUIPMENT TYPE	SIZE CATEGORY	HEATING SECTION TYPE	SUBCATEGORY OR RATING CONDITION	MINIMUM EFFICIENCY	TEST PROCEDURE ^a
VRF air cooled (cooling mode)	< 65,000 Btu/h	All	VRF multisplit system	15.0 SEER 12.5 EER	AHRI 1230
	≥ 65,000 Btu/h and < 135,000 Btu/h	Electric resistance (or none)	VRF multisplit system	11.3 EER 14.6 IEER	
	≥ 65,000 Btu/h and < 135,000 Btu/h	Electric resistance (or none)	VRF multisplit system with heat recovery	11.1 EER 14.4 IEER	
	≥ 135,000 Btu/h and < 240,000 Btu/h	Electric resistance (or none)	VRF multisplit system	10.9 EER 13.9 IEER	
	≥ 135,000 Btu/h and < 240,000 Btu/h	Electric resistance (or none)	VRF multisplit system with heat recovery	10.7 EER 13.7 IEER	
	≥ 240,000 Btu/h	Electric resistance (or none)	VRF multisplit system	10.3 EER 12.7 IEER	
	≥ 240,000 Btu/h	Electric resistance (or none)	VRF multisplit system with heat recovery	10.1 EER 12.5 IEER	
VRF water source (cooling mode)	< 65,000 Btu/h	All	VRF multisplit systems 86°F entering water	14.0 EER 16.0 IEER	AHRI 1230
	< 65,000 Btu/h	All	VRF multisplit systems with heat recovery 86°F entering water	13.8 EER 15.8 IEER	
	≥ 65,000 Btu/h and < 135,000 Btu/h	All	VRF multisplit system 86°F entering water	14.0 EER 16.0 IEER	
	≥ 65,000 Btu/h and < 135,000 Btu/h	All	VRF multisplit system with heat recovery 86°F entering water	13.8 EER 15.8 IEER	
	≥ 135,000 Btu/h	All	VRF multisplit system 86°F entering water	11.6 EER 14.0 IEER	
	≥ 135,000 Btu/h	All	VRF multisplit system with heat recovery 86°F entering water	11.2 EER 13.8 IEER	
VRF groundwater source (cooling mode)	< 135,000 Btu/h	All	VRF multisplit system 59°F entering water	16.2 EER	AHRI 1230
	< 135,000 Btu/h	All	VRF multisplit system with heat recovery 59°F entering water	16.0 EER	
	≥ 135,000 Btu/h	All	VRF multisplit system 59°F entering water	13.8 EER	
	≥ 135,000 Btu/h	All	VRF multisplit system with heat recovery 59°F entering water	13.6 EER	
VRF ground source (cooling mode)	< 135,000 Btu/h	All	VRF multisplit system 77°F entering water	13.4 EER	AHRI 1230
	< 135,000 Btu/h	All	VRF multisplit system with heat recovery 77°F entering water	13.2 EER	
	≥ 135,000 Btu/h	All	VRF multisplit system 77°F entering water	11.0 EER	
	≥ 135,000 Btu/h	All	VRF multisplit system with heat recovery 77°F entering water	10.8 EER	

a. Chapter 11 (Section 11) contains details for the referenced test procedure, including year version of the test procedure.

(continued)

TABLE B101.11 (TABLE B-11)
(SUPERSEDES TABLE 6.8.1-10 IN ANSI/ASHRAE/IES STANDARD 90.1)
ELECTRICALLY OPERATED VARIABLE-REFRIGERANT-FLOW AND APPLIED
HEAT PUMP—MINIMUM EFFICIENCY REQUIREMENTS (I-P) (Continued)

EQUIPMENT TYPE	SIZE CATEGORY	HEATING SECTION TYPE	SUBCATEGORY OR RATING CONDITION	MINIMUM EFFICIENCY	TEST PROCEDURE ^a
VRF air cooled (heating mode)	< 65,000 Btu/h (cooling capacity)		VRF multisplit system	8.5 HSPF	AHRI 1230
	≥ 65,000 Btu/h and < 135,000 Btu/h (cooling capacity)		VRF multisplit system 47°F db/43°F wb <i>outdoor air</i>	3.40 COP _H	
			VRF multisplit system 17°F db/15°F wb <i>outdoor air</i>	2.40 COP _H	
	≥ 135,000 Btu/h (cooling capacity)		VRF multisplit system 47°F db/43°F wb <i>outdoor air</i>	3.20 COP _H	
VRF multisplit system 17°F db/15°F wb <i>outdoor air</i>			2.10 COP _H		
VRF water source (heating mode)	< 135,000 Btu/h (cooling capacity)		VRF multisplit system 68°F entering water	4.60 COP _H	AHRI 1230
	≥ 135,000 Btu/h (cooling capacity)		VRF multisplit system 68°F entering water	4.20 COP _H	
VRF groundwater source (heating mode)	< 135,000 Btu/h (cooling capacity)		VRF multisplit system 50°F entering water	3.60 COP _H	AHRI 1230
	≥ 135,000 Btu/h (cooling capacity)		VRF multisplit system 50°F entering water	3.30 COP _H	
VRF ground source (heating mode)	< 135,000 Btu/h (cooling capacity)		VRF multisplit system 32°F entering fluid	3.10 COP _H	AHRI 1230
	≥ 135,000 Btu/h (cooling capacity)		VRF multisplit system 32°F entering fluid	2.80 COP _H	

a. Chapter 11 (Section 11) contains details for the referenced test procedure, including year version of the test procedure.

TABLE B101.1 (TABLE B-1)
(SUPERSEDES TABLE 6.8.1-1 IN ANSI/ASHRAE/IES STANDARD 90.1)
ELECTRICALLY OPERATED UNITARY AIR CONDITIONERS AND
CONDENSING UNITS—MINIMUM EFFICIENCY REQUIREMENTS (SI)

EQUIPMENT TYPE	SIZE CATEGORY	HEATING SECTION TYPE	SUBCATEGORY OR RATING CONDITIONS	MINIMUM EFFICIENCY	TEST PROCEDURE ^a
Air conditioners, air cooled	< 19 kW (one phase)	All	Split systems	4.40 SCOP _C 3.66 COP _C	AHRI 210/240
			Single packaged	4.40 SCOP _C 3.52 COP _C	
	< 19 kW (three phase)	All	Split systems	4.40 SCOP _C 3.52 COP _C	
			Single packaged	4.10 SCOP _C 3.40 COP _C	
Through-the-wall, air cooled	< 9 kW	All	Split systems	3.52 SCOP _C	
			Single packaged	3.52 SCOP _C	
Small duct, high velocity, air cooled	< 19 kW (one phase)	All	Split systems	3.52 SCOP _C	
	< 19 kW (three phase)	All	Split systems	3.52 SCOP _C	
Air conditioners air cooled	≥ 19 kW and < 40 kW	Electric resistance (or none)	Split systems and single package	3.58 COP _C 4.10 ICOP _C	ARI 340/360
		All other	Split systems and single package	3.52 COP _C 4.04 ICOP _C	
	≥ 40 kW and < 70 kW	Electric resistance (or none)	Split systems and single package	3.58 COP _C 3.87 ICOP _C	
		All other	Split systems and single package	3.52 COP _C 3.81 ICOP _C	
	≥ 70 kW and < 223 kW	Electric resistance (or none)	Split systems and single package	3.17 COP _C 3.60 ICOP _C	
		All other	Split systems and single package	3.11 COP _C 3.55 ICOP _C	
	≥ 223 kW	Electric resistance (or none)	Split systems and single package	3.05 COP _C 3.40 ICOP _C	
		All other	Split systems and single package	2.99 COP _C 3.34 ICOP _C	

a. Chapter 11 (Section 11) contains a details on the referenced test procedures, including year and version of the test procedure.

(continued)

TABLE B101.1 (TABLE B-1)
(SUPERSEDES TABLE 6.8.1-1 IN ANSI/ASHRAE/IES STANDARD 90.1)
ELECTRICALLY OPERATED UNITARY AIR CONDITIONERS AND
CONDENSING UNITS—MINIMUM EFFICIENCY REQUIREMENTS (SI) (Continued)

EQUIPMENT TYPE	SIZE CATEGORY	HEATING SECTION TYPE	SUBCATEGORY OR RATING CONDITIONS	MINIMUM EFFICIENCY	TEST PROCEDURE ^a
Air conditioners, water cooled	< 19 kW	All	Split systems and single package	4.10 COP _c	AHRI 210/240
			Split systems and single package	4.48 ICOP _c	
	≥ 19 kW and < 140 kW	Electric resistance (or none)	Split systems and single package	4.10 COP _c 4.48 ICOP _c	AHRI 340/360
		All other	Split systems and single package	4.04 COP _c 4.43 ICOP _c	
	≥ 40 kW and < 70 kW	Electric resistance (or none)	Split systems and single package	4.10 COP _c 4.34 ICOP _c	
		All other	Split systems and single package	4.04 COP _c 4.28 ICOP _c	
	≥ 70 kW and < 223 kW	Electric resistance (or none)	Split systems and single package	4.10 COP _c 4.34 ICOP _c	
		All other	Split systems and single package	3.99 COP _c 4.28 ICOP _c	
	≥ 223 kW	Electric resistance (or none)	Split systems and single package	4.10 COP _c 4.34 ICOP _c	
		All other	Split systems and single package	4.04 COP _c 4.28 ICOP _c	
Air conditioners, evaporatively cooled	< 19 kW	All	Split systems and single package	4.10 COP _c 4.48 ICOP _c	AHRI 210/240
	≥ 19 kW and < 140 kW	Electric resistance (or none)	Split systems and single package	4.10 COP _c 4.48 ICOP _c	AHRI 340/360
		All other	Split systems and single package	4.04 COP _c 4.43 ICOP _c	
	≥ 40 kW and < 70 kW	Electric resistance (or none)	Split systems and single package	3.96 COP _c 4.19 ICOP _c	
		All other	Split systems and single package	3.90 COP _c 4.13 ICOP _c	
	≥ 70 kW and < 223 kW	Electric resistance (or none)	Split systems and single package	3.96 COP _c 4.19 ICOP _c	
		All other	Split systems and single package	3.90 COP _c 4.13 ICOP _c	
	≥ 223 kW	Electric resistance (or none)	Split systems and single package	3.96 COP _c 4.19 ICOP _c	
		All other	Split systems and single package	3.90 COP _c 4.13 ICOP _c	
	Condensing units, air cooled	≥ 40 kW			Not applicable match with indoor coil
Condensing, water or evaporatively cooled	40 kW			Not applicable match with indoor coil	

a. Chapter 11 (Section 11) contains a details on the referenced test procedures, including year and version of the test procedure.

TABLE B101.2 (TABLE B-2)
(SUPERSEDES TABLE 6.8.1-2 IN ANSI/ASHRAE/IES STANDARD 90.1)
ELECTRICALLY OPERATED UNITARY AND APPLIED HEAT PUMPS—MINIMUM EFFICIENCY REQUIREMENTS (SI)

EQUIPMENT TYPE	SIZE CATEGORY	HEATING SECTION TYPE	SUBCATEGORY OR RATING CONDITIONS	MINIMUM EFFICIENCY	TEST PROCEDURE ^a
Air conditioners, air cooled (cooling mode)	< 19 kW (one phase)	All	Split systems	4.40 SCOP _C 3.66 COP _C	AHRI 210/240
			Single packaged	4.40 SCOP _C 3.52 COP _C	
	< 19 kW (three phase)	All	Split systems	4.40 SCOP _C 3.66 COP _C	
			Single packaged	4.40 SCOP _C 3.52 COP _C	
Through-the-wall, air cooled (cooling mode)	< 9 kW	All	Split systems	3.52 SCOP _C	AHRI 210/240
			Single packaged	3.52 SCOP _C	
Small duct high velocity, air cooled (cooling mode)	< 19 kW (one phase)	All	Split systems	3.52 SCOP _C	AHRI 210/240
	< 19 kW (three phase)	All	Split systems	3.52 SCOP _C	
Air conditioners, air cooled (cooling mode)	≥ 19 kW and < 40 kW	Electric resistance (or none)	Split systems and single package	3.31 COP _C 3.60 ICOP _C	AHRI 340/360
		All other	Split systems and single package	3.25 COP _C 3.55 ICOP _C	
	≥ 40 kW and < 70 kW	Electric resistance (or none)	Split systems and single package	3.19 COP _C 3.40 ICOP _C	
		All other	Split systems and single package	3.14 COP _C 3.34 ICOP _C	
	≥ 70 kW	Electric resistance (or none)	Split systems and single package	3.02 COP _C 3.11 ICOP _C	
		All other	Split systems and single package	2.96 COP _C 3.05 ICOP _C	
Water-to-air water loop (cooling mode)	< 5 kW	All	30°C entering water	4.10 COP _C	ISO-13256-1
	≥ 5 kW and < 19kW	All	30°C entering water	4.10 COP _C	
	> 19kW and < 40 kW	All	30°C entering water	4.10 COP _C	
Water-to-air ground water (cooling mode)	< 40 kW	All	15°C entering water	5.28 COP _C	ISO-13256-1
Water-to-air ground loop (cooling mode)	< 40 kW	All	25°C entering water	4.13 COP _C	
Water-to-water water loop (cooling mode)	< 40 kW	All	30°C entering water	3.11 COP _C	
Water-to-water groundwater (cooling mode)	< 40 kW	All	15°C entering water	4.78 COP _C	ISO-13256-2
Brine-to-water ground loop (cooling mode)	< 40 kW	All	30° C entering water	3.55 COP _C	
Air conditioners, air cooled (heating mode)	< 19kW (cooling capacity) (one phase)	All	Split systems	2.49 COP _H	AHRI 210/240
			Single packaged	2.40 COP _H	
	< 19kW (cooling capacity) (three phase)	All	Split systems	2.49 COP _H	
			Single packaged	2.40 COP _H	

a. Chapter 11 (Section 11) contains details on the referenced test procedures, including year and version of the test procedure.

(continued)

TABLE B101.2 (TABLE B-2)
(SUPERSEDES TABLE 6.8.1-2 IN ANSI/ASHRAE/IES STANDARD 90.1)
ELECTRICALLY OPERATED UNITARY AND APPLIED HEAT PUMPS—MINIMUM EFFICIENCY REQUIREMENTS (SI) (Continued)

EQUIPMENT TYPE	SIZE CATEGORY	HEATING SECTION TYPE	SUBCATEGORY OR RATING CONDITIONS	MINIMUM EFFICIENCY	TEST PROCEDURE ^a
Through-the-wall, air cooled (heating mode)	< 9 kW (cooling capacity)	All	Split systems	2.17 COP _H	AHRI 210/240
			Single packaged	2.17 COP _H	
Small-duct high velocity, air cooled (heating mode)	< 19kW (cooling capacity) (one phase)	All	Split systems	2.11 COP _H	AHRI 210/240
	< 19kW (cooling capacity) (three phase)	All	Split systems	2.11 COP _H	
Air cooled (heating mode)	≥ 19kW and < 40 kW (cooling capacity)		8.3°C db/6.1°C wb outdoor air	3.40 COP _H	AHRI 340/360
			-8.3°C db/9.4°C wb outdoor air	2.40 COP _H	
	≥ 40 kW (cooling capacity)		8.3°C db/6.1°C wb outdoor air	3.20 COP _H	
			-8.3°C db/9.4°C wb outdoor air	2.10 COP _H	
Water-to-air water loop (heating mode)	< 40 kW (cooling capacity)		20°C entering water	4.60 COP _H	ISO-1356-1
Water-to-air groundwater (heating mode)	< 40 kW (cooling capacity)		10°C entering water	3.70 COP _H	
Brine-to-air ground loop (heating mode)	< 40 kW (cooling capacity)		0°C entering fluid	3.20 COP _H	
Water-to-water water loop (heating mode)	< 40 kW (cooling capacity)		20°C entering water	3.70 COP _H	ISO-13256-2
Water-to-water groundwater (heating mode)	< 40 kW (cooling capacity)		10°C entering water	3.10 COP _H	
Brine-to-water ground loop (heating mode)	< 40 kW (cooling capacity)		0°C entering fluid	2.50 COP _H	

a. Chapter 11 (Section 11) contains details on the referenced test procedures, including year and version of the test procedure.

TABLE B101.3 (TABLE B-3)
(SUPERSEDES TABLE 6.8.1-4 IN ANSI/ASHRAE/IES STANDARD 90.1)
ELECTRICALLY OPERATED SINGLE-PACKAGED VERTICAL AIR CONDITIONERS AND SINGLE-PACKAGED
VERTICAL HEAT PUMPS AIR-CONDITIONER HEAT PUMPS—MINIMUM EFFICIENCY REQUIREMENTS (SI)

EQUIPMENT TYPE	SIZE CATEGORY (INPUT)	SUBCATEGORY OR RATING CONDITION	MINIMUM EFFICIENCY	TEST PROCEDURE ^a
PTAC (cooling mode) standard size	All capacities	35°C db <i>outdoor air</i>	$4.22 - (0.300 \times \text{Cap}/1000)^{\circ} \text{COP}_C$	AHRI 310/380
PTAC (cooling mode) nonstandard size ^b	All capacities	35°C db <i>outdoor air</i>	$3.19 - (0.213 \times \text{Cap}/1000)^{\circ} \text{COP}_C$	AHRI 310/380
PTHP (cooling mode) standard size	All capacities	35°C db <i>outdoor air</i>	$4.22 - (0.300 \times \text{Cap}/1000)^{\circ} \text{COP}_C$	ARI 310/380
PTHP (cooling mode) nonstandard size ^b	< 7,000 Btu/h	35°C db <i>outdoor air</i>	$3.16 - (0.213 \times \text{Cap}/1000)^{\circ} \text{COP}_C$	ARI 310/380
PTHP (heating mode) new constructions	All capacities	8.3°C db/6.1°C wb <i>outdoor air</i>	$3.7 - (0.052 \times \text{Cap}/1000)^{\circ} \text{COP}_H$	ARI 310/380
PTHP (heating mode) nonstandard size ^b	All capacities	8.3°C db/6.1°C wb <i>outdoor air</i>	$2.9 - (0.026 \times \text{Cap}/1000)^{\circ} \text{COP}_H$	ARI 310/380

- a. Chapter 11 (Section 11) contains a complete specification of the referenced test procedures, including year version of the test procedure.
- b. Replacement units shall be factory labeled as follows: “MANUFACTURED FOR REPLACEMENT APPLICATIONS ONLY; NOT TO BE INSTALLED IN NEW CONSTRUCTION PROJECTS.” Replacement efficiencies apply only to units with existing sleeves less than 0.45 m. high and less than 1.0 m. wide and having a cross-sectional area less than 0.43 m².
- c. “Cap” means the rated cooling capacity of the product in Btu/h. If the unit’s capacity is less than 2.1 kW, use 2.1 kW in the calculation. If the unit’s capacity is greater than 4.4 kW, use 4.4 kW in the calculation.

TABLE B101.4 (TABLE B-4)
(SUPERSEDES TABLE 6.8.1-4 IN ANSI/ASHRAE/IES STANDARD 90.1)
SINGLE-PACKAGED VERTICAL AIR CONDITIONERS, SINGLE-PACKAGED VERTICAL HEAT PUMPS, ROOM AIR CONDITIONERS, AND ROOM AIR-CONDITIONER HEAT PUMPS—MINIMUM EFFICIENCY REQUIREMENTS (SI)

EQUIPMENT TYPE	SIZE CATEGORY (INPUT)	SUBCATEGORY OR RATING CONDITION	MINIMUM EFFICIENCY BASE	MINIMUM EFFICIENCY CONNECTED ^b	TEST PROCEDURE ^a
SPVAC (cooling mode)	< 19 kW	35°C db/23.9°C wb <i>outdoor air</i>	4.10 SCOP _C		AHRI 210/240
	≥ 19 kW and < 40 kW	35°C db/23.9°C wb <i>outdoor air</i>	3.28 COP _C 3.78 ICOP _C		AHRI 340/360
	≥ 40 kW and < 70 kW	35°C db/23.9°C wb <i>outdoor air</i>	3.22 COP _C 3.63 ICOP _C		
SPVHP (cooling mode)	< 19 kW	35°C db/23.9°C wb <i>outdoor air</i>	4.10 SCOP _C		AHRI 210/240
	≥ 19 kW and < 40 kW	35°C db/23.9°C wb <i>outdoor air</i>	3.22 COP _C 3.58 ICOP _C		AHRI 340/360
	≥ 40 kW and < 70 kW	35°C db/23.9°C wb <i>outdoor air</i>	3.11 COP _C 3.40 ICOP _C		
SPVHP (heating mode)	< 19 kW	8.3°C db/6.1°C wb <i>outdoor air</i>	2.34 SCOP _H		AHRI 210/240
	≥ 19 kW and < 40 kW	8.3°C db/6.1°C wb <i>outdoor air</i>	3.30 COP _H		AHRI 340/360
	≥ 40 kW and < 70 kW	8.3°C db/6.1°C wb <i>outdoor air</i>	3.2 COP _H		
Room air conditioners, with louvered sides	< 1.8 kW		3.55 CCOP _C	3.37 CCOP _C	ANSI/AHAM RAC-1
	≥ 1.8 kW and < 2.3 kW		3.55 CCOP _C	3.37 CCOP _C	
	≥ 2.3 kW and < 4.1 kW		3.52 CCOP _C	3.37 CCOP _C	
	≥ 4.1 kW and < 5.9 kW		3.46 CCOP _C	3.28 CCOP _C	
	≥ 5.9 kW and < 8.2 kW		3.02 CCOP _C	2.87 CCOP _C	
	≥ 8.2 kW		2.90 CCOP _C	2.75 CCOP _C	
Room air conditioners, without louvered sides	< 1.8 kW		3.22 CCOP _C	3.08 CCOP _C	
	≥ 1.8 kW and < 2.3 kW		3.22 CCOP _C	3.08 CCOP _C	
	≥ 2.3 kW and < 3.2 kW		3.11 CCOP _C	2.96 CCOP _C	
	≥ 3.2 kW and < 4.1 kW		3.08 CCOP _C	2.93 CCOP _C	
	≥ 4.1 kW and < 5.9 kW		2.99 CCOP _C	2.84 CCOP _C	
	≥ 5.9 kW		3.02 CCOP _C	2.87 CCOP _C	
Room air conditioner heat pump, with louvered sides	< 5.9 kW	3.17 CCOP _C	3.02 CCOP _C		
	≥ 5.9 kW	2.99 CCOP _C	2.84 CCOP _C		
Room air conditioner heat pump, without louvered sides	< 4.1 kW	2.99 CCOP _C	2.84 CCOP _C		
	≥ 4.1 kW	2.81 CCOP _C	2.67 CCOP _C		
Room air conditioner, casement only	All capacities	3.08 CCOP _C	2.93 CCOP _C		
Room air conditioner, casement-slider	All capacities	3.34 CCOP _C	3.17 CCOP _C		

- a. Chapter 11 (Section 11) contains details for the referenced test procedure, including the referenced year version of the test procedure.
- b. Connected room air conditioners that are connected to utility programs are allowed a lower *CEER* value but must be in compliance with and certified per ENERGY STAR version 4.0 requirements for connected equipment.

TABLE B101.5 (TABLE B-5)
(SUPERSEDES TABLE 6.8.1-5 IN ANSI/ASHRAE/IES STANDARD 90.1)
WARM-AIR FURNACES AND COMBINATION WARM-AIR FURNACES/AIR-CONDITIONING UNITS, WARM-AIR DUCT FURNACES, AND UNIT HEATERS—MINIMUM EFFICIENCY REQUIREMENTS (SI)

EQUIPMENT TYPE	SIZE CATEGORY (INPUT)	SUBCATEGORY OR RATING CONDITION	MINIMUM EFFICIENCY	TEST PROCEDURE ^a
Warm-air furnace, gas fired (weatherized)	< 65.9 kW	Maximum capacity ^c	78% AFUE or 80% E_t ^{b,d}	DOE 10 CFR Part 430 or Section 2.39, Thermal Efficiency, ANSI Z21.47
	≥ 65.9 kW		80% E_t ^d	Section 2.39, Thermal Efficiency, ANSI Z21.47
Warm-air furnace, gas fired (nonweatherized)	< 65.9 kW	Maximum capacity ^c	90% AFUE or 92% E_t ^{b,d}	DOE 10 CFR Part 430 or Section 2.39, Thermal Efficiency, ANSI Z21.47
	≥ 65.9 kW		92% E_t ^d	Section 2.39, Thermal Efficiency, ANSI Z21.47
Warm-air furnace, oil fired (weatherized)	< 65.9 kW	Maximum capacity ^c	78% AFUE or 80% E_t ^{b,d}	DOE 10 CFR Part 430 or Section 42, Combustion, UL 727
	> 65.9 kW		81% E_t ^d	Section 42, Combustion, UL 727
Warm-air furnace, oil fired (nonweatherized)	< 65.9 kW	Maximum capacity ^c	85% AFUE or 87% E_t ^{b,d}	DOE 10 CFR Part 430 or Section 42, Combustion, UL 727
	≥ 65.9 kW		87% E_t ^d	Section 42, Combustion, UL 727
Warm-air duct furnaces, gas fired (weatherized)	All capacities	Maximum capacity ^c	80% E_c ^e	Section 2.10, Efficiency, ANSI Z83.8
Warm-air duct furnaces, gas fired (nonweatherized)	All capacities	Maximum capacity ^c	90% E_c ^e	Section 2.10, Efficiency, ANSI Z83.8
Warm-air unit heaters, gas fired (nonweatherized)	All capacities	Maximum capacity ^c	80% E_c ^{e,f}	Section 2.10, Efficiency, ANSI Z83.8
Warm-air unit heaters, oil fired (weatherized)	All capacities	Maximum capacity ^c	90% E_c ^{e,f}	Section 40, Combustion, UL 731

- a. Chapter 11 (Section 11) contains a complete specification of the referenced test procedure, including the referenced year version of the test procedure.
- b. Combination units not covered by the U.S. Department of Energy Code of Federal Regulations 10 CFR 430 (three-phase power or cooling capacity greater than or equal to 19 kW) may comply with either rating.
- c. Compliance of multiple firing rate units shall be at the maximum firing rate.
- d. E_t = thermal efficiency. Units must also include an interrupted or intermittent ignition device (IID), have jacket losses not exceeding 0.75% of the input rating, and have either power venting or a flue damper. A vent damper is an acceptable alternative to a flue damper for those furnaces where combustion air is drawn from the conditioned space.
- e. E_c = combustion efficiency (100% less flue losses). See test procedure for detailed discussion.
- f. As of August 8, 2008, according to the Energy Policy Act of 2005, units must also include an interrupted or intermittent ignition device (IID) and have either power venting or an automatic flue damper.

**TABLE B101.6 (TABLE B-6)
(SUPERSEDES TABLE 6.8.1-6 IN ANSI/ASHRAE/IES STANDARD 90.1)
GAS- AND OIL-FIRED BOILERS—MINIMUM EFFICIENCY REQUIREMENTS (SI)**

EQUIPMENT TYPE ^a	SUBCATEGORY OR RATING CONDITION	SIZE CATEGORY (INPUT)	MINIMUM EFFICIENCY ^{b,c}	TEST PROCEDURE ^g
Boilers, hot water	Gas fired	< 87.9 kW ^{h,i}	89% AFUE ^f	10 CFR Part 430
		≥ 87.9 kW and < 732.7 kW ^d	89% E_t^f	10 CFR Part 431
		≥ 732.7 kW ^a	91% E_c^f	
	Oil fired ^e	< 87.9 kW	89% AFUE ^f	10 CFR Part 430
		≥ 87.9 kW and < 732.7 kW ^d	85% E_t^f	10 CFR Part 431
		≥ 732.7 kW ^a	86% E_c^f	
Boilers, steam	Gas fired	< 87.9 kW ⁱ	80% AFUE	10 CFR Part 430
	Gas fired all except natural draft	≥ 87.9 kW and < 732.7 kW ^d	79% E_t	10 CFR Part 431
		≥ 732.7 kW ^a	79% E_t	
	Gas fired natural draft	≥ 87.9 kW and < 732.7 kW ^d	77% E_t	
		≥ 732.7 kW ^a	77% E_t	
	Oil fired ^e	< 87.9 kW	82% AFUE	10 CFR Part 430
		≥ 87.9 kW and < 732.7 kW ^d	81% E_t	10 CFR Part 431
≥ 732.7 kW ^a		81% E_t		

- a. These requirements apply to boilers with rated input of 2344 kW or less that are not packaged boilers, and to all packaged boilers. Minimum efficiency requirements for boilers cover all capacities of packaged boilers.
- b. E_c = thermal efficiency (100% less flue losses). See reference document for detailed information.
- c. E_t = thermal efficiency. See reference document for detailed information.
- d. Maximum capacity—minimum and maximum ratings as provided for and allowed by the unit’s controls.
- e. Includes oil fired (residual).
- f. Systems shall be designed with lower operating return hot-water temperatures (< 55°C) and use hot-water reset to take advantage of the higher efficiencies of condensing boilers.
- g. Chapter 11 (Section 11) contains details for the referenced test procedure, including the referenced year version of the test procedure.
- h. A boiler not equipped with a tankless domestic water-heating coil shall be equipped with an *automatic* means for adjusting the temperature of the water such that an incremental change in inferred heat load produces a corresponding incremental change in the temperature of the water supplied.
- i. Boilers shall not be equipped with a continuous pilot ignition system.

**TABLE B101.7 (TABLE B-7)
(SUPERSEDES TABLE 6.8.1-7 IN ANSI/ASHRAE/IES STANDARD 90.1)
PERFORMANCE REQUIREMENTS FOR HEAT REJECTION EQUIPMENT—MINIMUM EFFICIENCY REQUIREMENTS (SI)**

EQUIPMENT TYPE	TOTAL SYSTEM HEAT REJECTION CAPACITY AT RATED CONDITIONS	SUBCATEGORY OR RATING CONDITION ^a	PERFORMANCE REQUIRED ^{a,b,c,d,e,f,i}	TEST PROCEDURE ^h
Propeller or axial fan open-circuit cooling towers	All	35.0°C entering water 29.4°C leaving water 23.9°C entering wb	≥ 3.56 L/s kW	CTI ATC-105 and CTI STD-201RS
Centrifugal fan open-circuit cooling towers	All	35.0°C entering water 29.4°C leaving water 23.9°C entering wb	≥ 1.86 L/s kW	CTI ATC-105 and CTI STD-201RS
Propeller or axial fan closed-circuit cooling towers	All	38.9°C entering water 32.2°C leaving water 23.9°C entering wb	≥ 1.36 L/s kW	CTI ATC-105S and CTI STD-201RS
Centrifugal fan closed-circuit cooling towers	All	38.9°C entering water 32.2°C leaving water 23.9°C entering wb	≥ 0.68 L/s kW	CTI ATC-105S and CTI STD-201RS
Propeller or axial fan evaporative condensers	All	Ammonia test fluid 60.0°C entering gas temperature 35.7°C condensing temperature 23.9°C entering wb	≥ 52.6 COP	CTI ATC-106
Centrifugal fan evaporative condensers	All	Ammonia test fluid 60.0°C entering gas temperature 35.7°C condensing temperature 23.9°C entering wb	≥ 43.2 COP	CTI ATC-106
Propeller or axial fan evaporative condensers	All	R-507A test fluid 73.9°C entering gas temperature 40.6°C condensing temperature 23.9°C entering wb	≥ 61.7 COP	CTI ATC-106
Centrifugal fan evaporative condensers	All	R-507A test fluid 73.9°C entering gas temperature 40.6°C condensing temperature 23.9°C entering wb	≥ 53.1 COP	CTI ATC-106
Air-cooled condensers	All	88°C entering gas temperature 52°C condensing temperature 8°C subcooling 35°C entering wb	≥ 69 COP	AHRI 460

- a. For purposes of this table, *open-circuit cooling tower performance* is defined as the water flow rating of the tower at the thermal rating condition listed in Table B101.8 (B-8) divided by the fan motor nameplate power.
- b. For purposes of this table, *closed-circuit cooling tower performance* is defined as the process water flow rating of the tower at the thermal rating condition listed in Table B101.8 (B-8) divided by the sum of the fan motor nameplate power and the integral spray pump motor nameplate power.
- c. For purposes of this table, *evaporative condenser performance* is defined as the heat rejected at the specified rating condition in the table divided by the sum of the fan motor nameplate power and the integral spray pump nameplate power.
- d. For purposes of this table, *air-cooled condenser performance* is defined as the heat rejected from the refrigerant divided by the fan motor nameplate power.
- e. The efficiencies and test procedures for both *open-* and *closed-circuit cooling towers* are not applicable to hybrid cooling towers that contain a combination of separate wet and dry heat exchange sections. The certification requirements do not apply to field erected cooling towers.
- f. All cooling towers, closed-circuit coolers, evaporative condensers and air-cooled condensers shall comply with the minimum efficiency listed in the table for that specific type of equipment with the capacity effect of any project specific accessories and/or options included with the equipment.
- g. Requirements for evaporative condensers are listed with ammonia (R-717) and R-507A as test fluids in the table. Evaporative condensers intended for use with halocarbon refrigerants other than R-507A must meet the minimum efficiency requirements listed for R-507A as the test fluid.
- h. Informative Appendix G contains information on the referenced test procedures.
- i. Not applicable for air-cooled condensers applied to condenserless chillers. The air-cooled condenser and condenserless chiller shall comply with the requirements for air-cooled chillers as defined in ANSI/ASHRAE/IES Standard 90.1, Table 6.8.1-3.

TABLE B101.8 (TABLE B-8)
(SUPERSEDES TABLE 7.8 IN ANSI/ASHRAE/IES STANDARD 90.1)
PERFORMANCE REQUIREMENTS FOR SERVICE WATER HEATING EQUIPMENT (SI)

EQUIPMENT TYPE	SIZE CATEGORY (INPUT)	RATED STORAGE VOLUME AND INPUT RATING (IF APPLICABLE)	DRAW PATTERN	PERFORMANCE REQUIRED ^{a, d}	TEST PROCEDURE ^b
Electric table-top water heaters ^c	≤ 12 kW	≥ 75.7 L and ≤ 454 L	Very small	UEF ≥ 0.6323 – 0.0015 <i>V</i>	DOE 10 CFR Part 430
			Low	UEF ≥ 0.9188 – 0.00082 <i>V</i>	
			Medium	UEF ≥ 0.9577 – 0.00061 <i>V</i>	
			High	UEF ≥ 0.9844 – 0.00042 <i>V</i>	
Electric resistance storage water heaters		≥ 75.7 L and ≤ 208 L	Very small	UEF ≥ 0.8808 – 0.00021 <i>V</i>	DOE 10 CFR Part 430
			Low	UEF ≥ 0.9254 – 0.000079 <i>V</i>	
			Medium	UEF ≥ 0.9307 – 0.000053 <i>V</i>	
			High	UEF ≥ 0.9349 – 0.000026 <i>V</i>	
		> 208 L		Must use heat-pump water heater	
Electric resistance grid-enabled water heaters		≥ 284 L	Very small	UEF ≥ 1.0136 – 0.00074 <i>V</i>	DOE 10 CFR Part 430
			Low	UEF ≥ 0.09984 – 0.00037 <i>V</i>	
			Medium	UEF ≥ 0.9853 – 0.00026 <i>V</i>	
			High	UEF ≥ 0.9720 – 0.00018 <i>V</i>	
Heat-pump water heaters		≤ 208 L		EF ≥ 2.00, FHR ≥ 190 L	DOE 10 CFR Part 430
		> 208 L		EF ≥ 2.20, FHR ≥ 190 L	
Gas-fired storage water heaters	≤ 22.0 kW	≤ 208 L		EF ≥ 0.67, FHR ≥ 250 L	DOE 10 CFR Part 430
	> 22.0 kWh	> 208 L		EF ≥ 0.77, FHR ≥ 250 L	
Gas instantaneous water heaters	> 14.6 kW and < 58.6 kW	≥ 309.7W/L and < 7.6 L		$E_t \geq 0.94$ or $EF \geq 0.93$ and $SL \leq 0.84 \times (Q/234 + 56.5\sqrt{V})$, W	DOE 10 CFR Part 430
	≥ 22.0 kW	≤ 530 L and ≥ 309.7W/L		$E_t \geq 0.94$ or $EF \geq 0.93$ and $SL = 0.84 \times (Q/234 + 56.5\sqrt{V})$, W	ANSI Z21.10.3
Oil storage water heaters	≤ 30.7 kW	≤ 190 L	Very small	EF = 0.2509 – 0.00032 <i>V</i>	DOE 10 CFR Part 430
			Low	EF = 0.5330 – 0.00042 <i>V</i>	
			Medium	EF = 0.6078 – 0.00042 <i>V</i>	
			High	EF = 0.6815 – 0.00037 <i>V</i>	
> 30.7 kW	< 309.7 W/L		$E_t \geq 80\%$ and $SL \leq (Q/234 + 56.5\sqrt{V})$, W	ANSI Z21.10.3	
Oil instantaneous water heaters	≤ 61.5 kW	≤ 190 L		EF ≥ 0.59 – 0.00050 <i>V</i>	DOE 10 CFR Part 430
	> 61.5 kW	≥ 309.7 W/L and < 38 L		$E_t \geq 80\%$	ANSI Z21.10.3
	> 61.5 kW	≥ 309.7W/L and ≥ 30 L		$E_t \geq 78\%$ and $SL \leq (Q/234 + 56.5\sqrt{V})$, W	
Solar water heater		Electric backup		SEF ≥ 1.8	ANSI Z21.10.3
		Gas backup		SEF ≥ 1.2	
Hot-water supply boilers, gas and oil	> 88 kW and ≤ 3660 kW	≥ 309.7 W/L and < 30 L		$E_t \geq 80\%$	ANSI Z21.10.3
Hot-water supply boilers, gas		≥ 309.7 W/L and ≥ 30 L		$E_t \geq 80\%$ and $SL \leq (Q/234 + 56.5\sqrt{V})$, W	ANSI Z21.10.3

- a. Energy factor (EF) and thermal efficiency (E_t) are minimum requirements, while standby loss (SL) is maximum W based on a 21°C temperature difference between stored water and ambient requirements. In the EF equation, V is the rated volume in litres. In the SL equation, V is the rated volume in litres and Q is the nameplate input rate in kW.
- b. Chapter 11 (Section 11) contains details on the referenced test procedures, including the year/version of the referenced test procedure.
- c. Section G.1 is titled “Test Method for Measuring Thermal Efficiency,” and Section G.2 is titled “Test Method for Measuring Standby Loss.”
- d. UEF is the Uniform Energy Factor and is a dimensionless number that is calculated per DOE 10 CFR Part 430 test procedures.

TABLE B101.8 (TABLE B-8)
(SUPERSEDES TABLE 7.8 IN ANSI/ASHRAE/IES STANDARD 90.1)
PERFORMANCE REQUIREMENTS FOR SERVICE WATER HEATING EQUIPMENT (SI) (Continued)

EQUIPMENT TYPE	SIZE CATEGORY (INPUT)	RATED STORAGE VOLUME AND INPUT RATING (IF APPLICABLE)	DRAW PATTERN	PERFORMANCE REQUIRED ^{a, d}	TEST PROCEDURE ^b
Hot-water supply boilers, oil		≥ 309.7 W/L and ≥ 30 L		$E_t \geq 78\%$ $SL \leq (Q/234 + 56.5\sqrt{V}), W$	ANSI Z21.10.3
Pool heaters, gas	All sizes			$E_t \geq 82\%$	ASHRAE 146
Pool heaters, oil	All sizes			$E_t \geq 78\%$	ASHRAE 146
Heat-pump pool heaters	All sizes	10°C db 6.8°C wb <i>outdoor air</i> 26.7°C entering water		≥ 4.0 COP	ASHRAE 146
Unfired storage tanks	All sizes			≥ R-2.2°C • m ² /W	None

- a. Energy factor (EF) and thermal efficiency (E_t) are minimum requirements, while standby loss (SL) is maximum W based on a 21°C temperature difference between stored water and ambient requirements. In the EF equation, V is the rated volume in litres. In the SL equation, V is the rated volume in litres and Q is the nameplate input rate in kW.
- b. Chapter 11 (Section 11) contains details on the referenced test procedures, including the year/version of the referenced test procedure.
- c. Section G.1 is titled “Test Method for Measuring Thermal Efficiency,” and Section G.2 is titled “Test Method for Measuring Standby Loss.”
- d. UEF is the Uniform Energy Factor and is a dimensionless number that is calculated per DOE 10 CFR Part 430 test procedures.

TABLE B101.9 (TABLE B-9)
COMMERCIAL CLOTHES WASHERS (SI)

PRODUCT	MEF ^a	WF ^b , L/L
All commercial clothes washers	48.7	0.53

- a. MEF = modified energy factor, a combination of energy factor and remaining moisture content. MEF measures energy consumption of the total laundry cycle (washing and drying). It indicates how many liters of laundry can be washed and dried with one kWh of electricity; the higher the number, the greater the efficiency.
- b. WF = water factor (in L/L).

TABLE B101.10 (TABLE B-10)
(SUPERSEDES TABLE 6.8.1-9 IN ANSI/ASHRAE/IES STANDARD 90.1)
ELECTRICALLY OPERATED VARIABLE-REFRIGERANT-FLOW (VRF) AIR CONDITIONERS—MINIMUM EFFICIENCY REQUIREMENTS (SI)

EQUIPMENT TYPE	SIZE CATEGORY	HEATING SECTION TYPE	SUBCATEGORY OR RATING CONDITION	MINIMUM EFFICIENCY	TEST PROCEDURE ^a
VRF air conditioners, air cooled	< 19 kW	All	VRF multisplit system	4.40 SCOP _C 3.36 COP _C	AHRI 1230
	≥ 19 kW and < 40 kW	Electric resistance (or none)	VRF multisplit system	3.43 COP _C 4.37 ICOP _C	
	≥ 40 kW and < 70 kW	Electric resistance (or none)	VRF multisplit system	3.43 COP _C 4.22 ICOP _C	
	≥ 70 kW	Electric resistance (or none)	VRF multisplit system	3.08 COP _C 3.81 ICOP _C	

- a. Chapter 11 (Section 11) contains details for the referenced test procedure, including year version of the test procedure.

**TABLE B101.11 (TABLE B-11)
(SUPERSEDES TABLE 6.8.1-10 IN ANSI/ASHRAE/IES STANDARD 90.1)
ELECTRICALLY OPERATED VARIABLE-REFRIGERANT-FLOW AND APPLIED
HEAT PUMP—MINIMUM EFFICIENCY REQUIREMENTS (SI)**

EQUIPMENT TYPE	SIZE CATEGORY	HEATING SECTION TYPE	SUBCATEGORY OR RATING CONDITION	MINIMUM EFFICIENCY	TEST PROCEDURE ^a
VRF air cooled (cooling mode)	< 19 kW	All	VRF multisplit system	4.40 SCOP _C 3.66 COP _C	AHRI 1230
	≥ 19 kW and < 40 kW	Electric resistance (or none)	VRF multisplit system	3.31 COP _C 4.28 ICOP _C	
	≥ 19 kW and < 40 kW	Electric resistance (or none)	VRF multisplit system with heat recovery	3.25 COP _C 4.22 ICOP _C	
	≥ 40 kW and < 70 kW	Electric resistance (or none)	VRF multisplit system	3.19 COP _C 4.07 ICOP _C	
	≥ 40 kW and < 70 kW	Electric resistance (or none)	VRF multisplit system with heat recovery	3.14 COP _C 4.02 ICOP _C	
	≥ 70 kW	Electric resistance (or none)	VRF multisplit system	3.02 COP _C 4.02 ICOP _C	
	≥ 70 kW	Electric resistance (or none)	VRF multisplit system with heat recovery	2.96 COP _C 3.66 ICOP _C	
VRF water source (cooling mode)	< 19 kW	All	VRF multisplit systems 30°C entering water	4.10 COP _C 4.69 ICOP _C	AHRI 1230
	< 19 kW	All	VRF multisplit systems with heat recovery 30°C entering water	4.04 COP _C 4.63 ICOP _C	
	≥ 19 kW and < 40 kW	All	VRF multisplit system 30°C entering water	4.10 COP _C 4.69 ICOP _C	
	≥ 19 kW and < 40 kW	All	VRF multisplit system with heat recovery 30°C entering water	4.04 COP _C 4.63 ICOP _C	
	≥ 40 kW	All	VRF multisplit system 30°C entering water	3.40 COP _C 4.10 ICOP _C	
	≥ 40 kW	All	VRF multisplit system with heat recovery 30°C entering water	3.28 COP _C 4.04 ICOP _C	
VRF groundwater source (cooling mode)	< 40 kW	All	VRF multisplit system 15°C entering water	4.75 COP _C	AHRI 1230
	< 40 kW	All	VRF multisplit system with heat recovery 15°C entering water	4.69 COP _C	
	≥ 40 kW	All	VRF multisplit system 15°C entering water	4.04 COP _C	
	≥ 40 kW	All	VRF multisplit system with heat recovery 15°C entering	3.99 COP _C	

a. Chapter 11 (Section 11) contains a complete specification of the reference test procedure, including year version of the test procedure.

(continued)

TABLE B101.11 (TABLE B-11)
(SUPERSEDES TABLE 6.8.1-10 IN ANSI/ASHRAE/IES STANDARD 90.1)
ELECTRICALLY OPERATED VARIABLE-REFRIGERANT-FLOW AND APPLIED
HEAT PUMP—MINIMUM EFFICIENCY REQUIREMENTS (SI) (Continued)

EQUIPMENT TYPE	SIZE CATEGORY	HEATING SECTION TYPE	SUBCATEGORY OR RATING CONDITION	MINIMUM EFFICIENCY	TEST PROCEDURE ^a
VRF ground source (cooling mode)	< 40 kW	All	VRF multisplit system 25°C entering water	3.93 COP _C	AHRI 1230
	< 40 kW	All	VRF multisplit system with heat recovery 25°C entering water	3.87 COP _C	
	≥ 40 kW	All	VRF multisplit system 25°C entering water	3.22 COP _C	
	≥ 40 kW	All	VRF multisplit system with heat recovery 25°C entering water	3.17 COP _C	
VRF air cooled (heating mode)	< 19 kW (cooling capacity)		VRF multisplit system	2.49 SCOP _H	AHRI 1230
	≥ 19 kW and < 40 kW (cooling capacity)		VRF multisplit system 8.3°C db/6.1°C wb <i>outdoor air</i>	3.40 COP _H	
			-8.3°C db/-9.4°C wb <i>outdoor air</i>	2.40 COP _H	
	≥ 40 kW (cooling capacity)		VRF multisplit system 8.3°C db/6.1°C wb <i>outdoor air</i>	3.20 COP _H	
		-8.3°C db/-9.4°C wb <i>outdoor air</i>	2.10 COP _H		
VRF water source (heating mode)	< 40 kW (cooling capacity)		VRF multisplit system 20°C entering water	4.60 COP _H	AHRI 1230
	≥ 40 kW (cooling capacity)		VRF multisplit system 20°C entering water	4.20 COP _H	
VRF groundwater source (heating mode)	< 40 kW (cooling capacity)		VRF multisplit system 10°C entering water	3.60 COP _H	AHRI 1230
	≥ 40 kW (cooling capacity)		VRF multisplit system 10°C entering water	3.30 COP _H	
VRF ground source (heating mode)	< 40 kW (cooling capacity)		VRF multisplit system 0°C entering fluid	3.10 COP _H	AHRI 1230
	≥ 40 kW (cooling capacity)		VRF multisplit system 0°C entering fluid	2.80 COP _H	

a. Chapter 11 (Section 11) contains a complete specification of the reference test procedure, including year version of the test procedure.

NORMATIVE APPENDIX C

PERFORMANCE OPTION FOR ENERGY EFFICIENCY

(This is a normative appendix and is part of this code.)

SECTION C101 (C1.) GENERAL

C101.1 (C1.1) Renewable, Recovered, and Purchased Energy. *On-site renewable energy systems* and *site recovered energy*: The modeling requirements for *on-site renewable energy systems* in the *proposed building performance* in ANSI/ASHRAE/IES Standard 90.1, Section G2.4.1, shall not apply and are superseded by Table C101.1 (C1.1), Section 15, “Renewable Energy Systems.”

C101.2 (C1.2) Building Performance Calculations. In addition to the requirements of ANSI/ASHRAE/IES Standard 90.1, Table G3.1, the *proposed design* shall comply with all modifications and additions in Table C101.1 (C1.1). All references to Table G3.1 in Table C101.1 (C1.1) refer to ANSI/ASHRAE/IES Standard 90.1, Appendix G, Table G3.1.

TABLE C101.1 (TABLE C1.1)
MODIFICATIONS AND ADDITIONS TO ANSI/ASHRAE/IES STANDARD 90.1, APPENDIX G, TABLE G3.1

PROPOSED BUILDING PERFORMANCE	BASELINE BUILDING PERFORMANCE
1. Design Model No modifications	No modifications
2. Additions and Alterations No modifications	No modifications
3. Space Use Classification No modifications	No modifications
4. Schedules No modifications	No modifications
5. Building Envelope No modifications	No modifications
6. Lighting No modifications	No modifications
7. Thermal Blocks—HVAC Zones Designed No modifications	No modifications
8. Thermal Blocks—HVAC Zones Not Designed No modifications	No modifications
9. Thermal Blocks—Multifamily Residential Buildings No modifications	No modifications
10. HVAC Systems No modifications	No modifications
11. Service Hot-Water Systems No modifications	No modifications
12. Receptacle and Other Loads No modifications	No modifications
13. Modeling Limitations to the Simulation Program No modifications	No modifications
14. Exterior Conditions No modifications	No modifications
15. On-Site Renewable Energy Systems The reduction in the <i>proposed building performance</i> and annual CO_2e of the <i>proposed design</i> due to energy generated by <i>on-site renewable energy systems</i> shall be calculated as follows: a. Annual Energy Cost. The annual energy cost of the <i>proposed design</i> with an <i>on-site renewable energy system</i> shall be calculated on an hourly basis and adjusted as follows: 1. Thermal Energy Performance Calculation. The hourly thermal loads of the <i>proposed design</i> shall be reduced by the hourly thermal energy production of the <i>on-site renewable energy system</i> (but thermal loads shall not be reduced to less than zero). When the on-site renewable thermal energy production exceeds the applicable thermal demands of the building for any hour, the excess generated energy may be used to displace thermal loads at other times, provided the system has the storage capability and storage losses are included in the calculation. The approved energy rate structure shall be applied to the reduced energy consumption.	

(continued)

TABLE C101.1 (TABLE C1.1)
MODIFICATIONS AND ADDITIONS TO ANSI/ASHRAE/IES STANDARD 90.1, APPENDIX G, TABLE G3.1 (Continued)

PROPOSED BUILDING PERFORMANCE	BASELINE BUILDING PERFORMANCE
<p>2. Electric Energy Performance Calculation. The total electrical energy production of the <i>on-site renewable energy system</i> shall be calculated on an hourly basis, and the energy cost of the <i>proposed building performance</i> shall be calculated by applying the approved electrical rate structure to each hour’s electrical usage, including any reduction from hourly electrical energy production of the <i>on-site renewable energy system</i>.</p> <p>Exception: For <i>building projects</i> with no net metering agreement, feed-in tariff, or other electrical rate structure for net generated electricity, the cost of imported electricity from the grid is calculated by applying the approved electrical rate structure to each hour’s electrical loads minus the hourly electrical energy production of the <i>on-site renewable energy system</i>, but the cost of imported electricity shall not be less than zero on a monthly basis.</p> <p>Electricity production of the <i>on-site renewable energy system</i> that has a retail value in excess of the retail cost of electricity consumption on a monthly basis shall be credited as a reduction in energy costs to the <i>building performance</i> at the wholesale rate as follows:</p> $\text{Credit} = \frac{(\text{ExRR} - \text{ImRR})}{\text{ExRR}} \times \text{ExkWh} \times \text{WR}$ <p>where:</p> <p>Credit = cost reduction credit for month where retail value of exported electricity is greater than retail value of imported electricity.</p> <p>ExRR = month’s value of exported electricity at retail rate.</p> <p>ImRR = month’s value of imported electricity at retail rate.</p> <p>ExkWh = total kilowatt-hours exported in month.</p> <p>WR = average monthly wholesale rate for the region where the building located.</p> <p>b. Annual CO₂e. The annual CO₂e of the proposed building that includes an <i>on-site renewable energy system</i> shall be equal to the annual CO₂e of the imported energy to serve the proposed building (with reduced loads due to the <i>on-site renewable energy system</i>) minus the annual exported electricity produced by the <i>on-site renewable energy system</i> multiplied by the electrical CO₂e emission factor.</p> <p>Documentation: The documentation required in ANSI/ASHRAE/IES Standard 90.1, Section G2.5 (a), (b), and (c), shall be made available to the <i>AHJ</i>, upon request, for all <i>on-site renewable energy systems</i> in the <i>proposed design</i>.</p>	

NORMATIVE APPENDIX D

BUILDING CONCENTRATIONS

(This is a normative appendix and is part of this code.)

SECTION D101 (D1.) BUILDING CONCENTRATIONS

Building concentrations shall be estimated based on the following parameters and criteria:

- a. Laboratory-measured volatile organic compound (VOC) emission factors and actual surface area of all materials as described in (b) below.
- b. At minimum, those materials listed in Section 801.5.2(a) through (g) [8.5.2(a) through (g)] to be installed shall be modeled.
- c. The actual building parameters for volume, average weekly minimum ventilation rate, and ventilated volume fraction for the building being modeled shall be used.
- d. Standard building scenarios or modeling from similar buildings shall not be allowed.
- e. Average weekly minimum air change rates shall be calculated based on the *minimum outdoor airflow* and hours of operation for the specific building being modeled.
- f. Steady-state conditions with respect to emission rates and building ventilation may be assumed.
- g. Zero *outdoor air* concentrations, perfect mixing within the building, and no net losses of VOCs from air due to other

effects such as irreversible or net sorption on surfaces (i.e., net sink effects) and chemical reactions may be assumed.

- h. All assumptions shall be clearly stated in the design documents.
- i. The estimated building concentration C_{Bi} ($\mu\text{g}/\text{m}^3$) of each target VOC shall be calculated using Equation 2 of CDPH/EHLB/Standard Method V1.1 (commonly referred to as California Section 01350), as shown below. Estimated building concentrations of individual target VOCs with multiple sources shall be added to establish a single total estimated building concentration for individual target VOCs.

$$C_{Bi} = (\text{EF}_{Ai} \times A_B) / (V_B \times a_B \times 0.9)$$

where:

EF_{Ai} = area specific emission rate or emission factor at 96 hours after placing a test specimen in the chamber (14 days total exposure time), $\mu\text{g}/\text{m}^2\cdot\text{h}$.

A_B = exposed surface area of the installed material in the building, m^2 .

V_B = building volume, m^3 .

a_B = average weekly minimum air change rate, 1/h.

INFORMATIVE APPENDIX E

BUILDING ENVELOPE TABLES

(This appendix is not part of this code. It is merely informative and does not contain requirements necessary for conformance to the code. It has not been processed according to the ANSI requirements for a code and may contain material that has not been subject to public review or a consensus process. Unresolved objectors on informative material are not offered the right to appeal at ASHRAE or ANSI.)

The first nine tables are in I-P units, followed by nine tables in SI units. U-factors, C-factors, F-factors, and *SHGC* in these tables meet the requirements of Section 701.4.2.1 (7.4.2.1), although the R-values in most cases provide more insulation than is required in Section 701.4.2.1 (7.4.2.1). These R-values represent common assemblies in building construction. Assemblies with lower R-values are allowed to be used to meet the criteria of Section 701.4.2.1 (7.4.2.1) when they meet the appropriate U-factor, C-factor, or F-factor criteria.

TABLE E101.0 (TABLE E-0)
(SUPERSEDES TABLE 5.5-0 IN ANSI/ASHRAE/IES STANDARD 90.1)
BUILDING ENVELOPE REQUIREMENTS FOR CLIMATE ZONE 0 (A,B)* (I-P)

OPAQUE ELEMENTS	NONRESIDENTIAL		RESIDENTIAL			SEMIHEATED			
	ASSEMBLY MAXIMUM	INSULATION MIN. R-VALUE**	ASSEMBLY MAXIMUM	INSULATION MIN. R-VALUE**	ASSEMBLY MAXIMUM	INSULATION MIN. R-VALUE**			
<i>Roofs</i>									
Insulation entirely above deck	U-0.039	R-25 c.i.	U-0.032	R-30 c.i.	U-0.218	R-3.8 c.i.			
Metal building ^a	U-0.041	R-10 + R-19 FC	U-0.041	R-10 + R-19 FC	U-0.115	R-10			
<i>Attic and other roofs</i>	U-0.027	R-38	U-0.027	R-38	U-0.081	R-13			
<i>Walls, above grade</i>									
Mass ^b	U-0.580	NR	U-0.151	R-5.7 c.i.	U-0.580	NR			
Metal building	U-0.094	R-0 + R-9.8 ci	U-0.094	R-0 + R-9.8 ci	U-0.352	NR			
Steel framed	U-0.124	R-13	U-0.124	R-13	U-0.352	NR			
Wood framed and other	U-0.089	R-13	U-0.089	R-13	U-0.292	NR			
<i>Wall, below grade</i>									
Below-grade wall	C-1.140	NR	C-1.140	NR	C-1.140	NR			
<i>Floors</i>									
Mass	U-0.322	NR	U-0.322	NR	U-0.322	NR			
Steel joist	U-0.350	NR	U-0.350	NR	U-0.350	NR			
Wood framed and other	U-0.282	NR	U-0.282	NR	U-0.282	NR			
<i>Slab-on-grade floors</i>									
Unheated	F-0.730	NR	F-0.730	NR	F-0.730	NR			
Heated	F-1.020	R-7.5 for 12 in.	F-1.020	R-7.5 for 12 in.	F-1.020	R-7.5 for 12 in.			
<i>Opaque doors</i>									
Swinging	U-0.370		U-0.370		U-0.700				
Nonswinging	U-0.310		U-0.310		U-1.450				
FENESTRATION	ASSEMBLY MAX. U	ASSEMBLY MAX. SHGC	ASSEMBLY MIN. VT/SHGC	ASSEMBLY MAX. U	ASSEMBLY MAX. SHGC	ASSEMBLY MIN. VT/SHGC	ASSEMBLY MAX. U	ASSEMBLY MAX. SHGC	ASSEMBLY MIN. VT/SHGC
Vertical glazing, 0% to 40% of wall		(for all frame types)			(for all frame types)			(for all frame types)	
Nonmetal framing (all)	U-0.30	E&W-0.21, N&S-0.22	1.10	U-0.30	E&W-0.21, N&S-0.22	1.10	U-0.88	NR	NR
Metal framing, fixed	U-0.48			U-0.48			U-1.14		
Metal framing, operable	U-0.62			U-0.62			U-1.14		
Metal framing, entrance door	U-0.79			U-0.79			U-1.05		
<i>Skylight, 0% to 3% of roof</i>									
All types	U-0.71	0.33	NR	U-0.71	0.33	NR	U-1.71	NR	NR

* The following definitions apply: c.i. = continuous insulation (see ANSI/ASHRAE/IES Standard 90.1, Section 3.2); NR = no (insulation) requirement; FC = filled cavity (see ANSI/ASHRAE/IES Standard 90.1, Section A2.3.2.5).

** The insulation minimum R-value criteria in this table meet the criteria in Section 701.4.2.1 (7.4.2.1), but it is possible that some assemblies with slightly less insulation minimum R-value will also meet the criteria of Section 701.4.2.1 (7.4.2.1).

- a. When using the R-value compliance method for metal building roofs, a thermal spacer block is required (see ANSI/ASHRAE/IES Standard 90.1, Section 3.2).
- b. Exception applies for mass walls above grade where the requirement is for a maximum assembly U-0.151 (see ANSI/ASHRAE/IES Standard 90.1, Section 5.5.3.2).

TABLE E101.1 (TABLE E-1)
(SUPERSEDES TABLE 5.5-1 IN ANSI/ASHRAE/IES STANDARD 90.1)
BUILDING ENVELOPE REQUIREMENTS FOR CLIMATE ZONE 1 (A,B)* (I-P)

OPAQUE ELEMENTS	NONRESIDENTIAL			RESIDENTIAL			SEMIHEATED		
	ASSEMBLY MAXIMUM	INSULATION MIN. R-VALUE**		ASSEMBLY MAXIMUM	INSULATION MIN. R-VALUE**		ASSEMBLY MAXIMUM	INSULATION MIN. R-VALUE**	
<i>Roofs</i>									
Insulation entirely above deck	U-0.048	R-20 c.i.		U-0.039	R-25 c.i.		U-0.218	R-3.8 c.i.	
Metal building ^a	U-0.041	R-10 + R-19 FC		U-0.041	R-10 + R-19 FC		U-0.115	R-10	
<i>Attic and other roofs</i>	U-0.027	R-38		U-0.027	R-38		U-0.081	R-13	
<i>Walls, above grade</i>									
Mass ^b	U-0.580	NR		U-0.151	R-5.7 c.i.		U-0.580	NR	
Metal building	U-0.094	R-0 + R-9.8 c.i.		U-0.094	R-0 + R-9.8 c.i.		U-0.352	NR	
Steel framed	U-0.124	R-13		U-0.124	R-13		U-0.352	NR	
Wood framed and other	U-0.089	R-13		U-0.089	R-13		U-0.292	NR	
<i>Wall, below grade</i>									
Below-grade wall	C-1.140	NR		C-1.140	NR		C-1.140	NR	
<i>Floors</i>									
Mass	U-0.322	NR		U-0.322	NR		U-0.322	NR	
Steel joist	U-0.350	NR		U-0.350	NR		U-0.350	NR	
Wood framed and other	U-0.282	NR		U-0.282	NR		U-0.282	NR	
<i>Slab-on-grade floors</i>									
Unheated	F-0.730	NR		F-0.730	NR		F-0.730	NR	
Heated	F-1.020	R-7.5 for 12 in.		F-1.020	R-7.5 for 12 in.		F-1.020	R-7.5 for 12 in.	
<i>Opaque doors</i>									
Swinging	U-0.370			U-0.370			U-0.700		
Nonswinging	U-0.310			U-0.310			U-1.450		
FENESTRATION	ASSEMBLY MAX. U	ASSEMBLY MAX. SHGC	ASSEMBLY MIN. VT/SHGC	ASSEMBLY MAX. U	ASSEMBLY MAX. SHGC	ASSEMBLY MIN. VT/SHGC	ASSEMBLY MAX. U	ASSEMBLY MAX. SHGC	ASSEMBLY MIN. VT/SHGC
Vertical glazing, 0% to 40% of wall		(for all frame types)			(for all frame types)			(for all frame types)	
Nonmetal framing, all	U-0.48	E&W-0.24, S-0.25, N-0.35	1.10	U-0.48	E&W-0.24, S-0.25, N-0.35	1.10	U-0.88	NR	NR
Metal framing, fixed	U-0.54			U-0.54			U-1.14		
Metal framing, operable	U-0.62			U-0.62			U-1.14		
Metal framing, entrance door	U-1.05			U-1.05			U-1.05		
<i>Skylight, 0% to 3% of roof</i>									
All types	U-0.71	0.33	NR	U-0.71	0.33	NR	U-1.71	NR	NR

* The following definitions apply: c.i. = continuous insulation (see ANSI/ASHRAE/IES Standard 90.1, Section 3.2); NR = no (insulation) requirement; FC = filled cavity (see ANSI/ASHRAE/IES Standard 90.1, Section A2.3.2.5).

** The insulation minimum R-value criteria in this table meet the criteria in Section 701.4.2.1 (7.4.2.1), but it is possible that some assemblies with slightly less insulation minimum R-value will also meet the criteria of Section 701.4.2.1 (7.4.2.1).

- a. When using the R-value compliance method for metal building roofs, a thermal spacer block is required (see ANSI/ASHRAE/IES Standard 90.1, Section 3.2).
- b. Exception applies for mass walls above grade where the requirement is for a maximum assembly U-0.151 (see ANSI/ASHRAE/IES Standard 90.1, Section 5.5.3.2).

TABLE E101.2 (TABLE E-2)
(SUPERSEDES TABLE 5.5-2 IN ANSI/ASHRAE/IES STANDARD 90.1)
BUILDING ENVELOPE REQUIREMENTS FOR CLIMATE ZONE 2 (A,B)* (I-P)

OPAQUE ELEMENTS	NONRESIDENTIAL		RESIDENTIAL			SEMIHEATED			
	ASSEMBLY MAXIMUM	INSULATION MIN. R-VALUE**	ASSEMBLY MAXIMUM	INSULATION MIN. R-VALUE**	ASSEMBLY MAXIMUM	INSULATION MIN. R-VALUE**			
<i>Roofs</i>									
Insulation entirely above deck	U-0.039	R-25 c.i.	U-0.039	R-25 c.i.	U-0.173	R-5 c.i.			
Metal building ^a	U-0.041	R-10 + R-19 FC	U-0.041	R-10 + R-19 FC	U-0.096	R-16			
<i>Attic and other roofs</i>	U-0.027	R-38	U-0.027	R-38	U-0.053	R-19			
<i>Walls, above grade</i>									
Mass ^b	U-0.151	R-5.7 c.i.	U-0.123	R-7.6 c.i.	U-0.580	NR			
Metal building	U-0.094	R-0 + R-9.8 c.i.	U-0.094	R-0 + R-9.8 c.i.	U-0.162	R-13			
Steel framed	U-0.084	R-13 + R-3.8 c.i.	U-0.064	R-13 + R-7.5 c.i.	U-0.124	R-13			
Wood framed and other	U-0.089	R-13	U-0.089	R-13	U-0.089	R-13			
<i>Wall, below grade</i>									
Below-grade wall	C-1.140	NR	C-1.140	NR	C-1.140	NR			
<i>Floors</i>									
Mass	U-0.107	R-6.3 c.i.	U-0.087	R-8.3 c.i.	U-0.322	NR			
Steel joist	U-0.038	R-30	U-0.038	R-30	U-0.069	R-13			
Wood framed and other	U-0.033	R-30	U-0.033	R-30	U-0.066	R-13			
<i>Slab-on-grade floors</i>									
Unheated	F-0.730	NR	F-0.730	NR	F-0.730	NR			
Heated	F-0.900	R-10 for 24 in.	F-0.860	R-15 for 24 in.	F-1.020	R-7.5 for 12 in.			
<i>Opaque doors</i>									
Swinging	U-0.370		U-0.370		U-0.700				
Nonswinging	U-0.310		U-0.310		U-1.450				
FENESTRATION	ASSEMBLY MAX. U	ASSEMBLY MAX. SHGC	ASSEMBLY MIN. VT/SHGC	ASSEMBLY MAX. U	ASSEMBLY MAX. SHGC	ASSEMBLY MIN. VT/SHGC	ASSEMBLY MAX. U	ASSEMBLY MAX. SHGC	ASSEMBLY MIN. VT/SHGC
Vertical glazing, 0% to 40% of wall		(for all frame types)			(for all frame types)			(for all frame types)	
Nonmetal framing, all	U-0.35	E&W-0.24, S-0.25, N-0.35	1.10	U-0.35	E&W-0.24, S-0.25, N-0.35	1.10	U-0.88	NR	NR
Metal framing, fixed	U-0.51			U-0.51			U-1.14		
Metal framing, operable	U-0.62			U-0.62			U-1.14		
Metal framing, entrance door	U-0.79			U-0.73			U-0.79		
<i>Skylight, 0% to 3% of roof</i>									
All types	U-0.62	0.33	NR	U-0.62	0.33	NR	U-1.71	NR	NR

* The following definitions apply: c.i. = continuous insulation (see ANSI/ASHRAE/IES Standard 90.1, Section 3.2); NR = no (insulation) requirement; FC = filled cavity (see ANSI/ASHRAE/IES Standard 90.1, Section A2.3.2.5).

** The insulation minimum R-value criteria in this table meet the criteria in Section 701.4.2.1 (7.4.2.1), but it is possible that some assemblies with slightly less insulation minimum R-value will also meet the criteria of Section 701.4.2.1 (7.4.2.1).

- a. When using the R-value compliance method for metal building roofs, a thermal spacer block is required (see ANSI/ASHRAE/IES Standard 90.1, Section 3.2).
- b. Exception applies for mass walls above grade where the requirement is for a maximum assembly U-0.151 (see ANSI/ASHRAE/IES Standard 90.1, Section 5.5.3.2).

TABLE E101.3 (TABLE E-3)
(SUPERSEDES TABLE 5.5-3 IN ANSI/ASHRAE/IES STANDARD 90.1)
BUILDING ENVELOPE REQUIREMENTS FOR CLIMATE ZONE 3 (A,B,C)* (I-P)

OPAQUE ELEMENTS	NONRESIDENTIAL			RESIDENTIAL			SEMIHEATED		
	ASSEMBLY MAXIMUM	INSULATION MIN. R-VALUE**		ASSEMBLY MAXIMUM	INSULATION MIN. R-VALUE**		ASSEMBLY MAXIMUM	INSULATION MIN. R-VALUE**	
<i>Roofs</i>									
Insulation entirely above deck	U-0.039	R-25 c.i.		U-0.039	R-25 c.i.		U-0.119	R-7.6 c.i.	
Metal building ^a	U-0.041	R-10 + R-19 FC		U-0.041	R-10 + R-19 FC		U-0.096	R-16	
<i>Attic and other roofs</i>	U-0.027	R-38		U-0.027	R-38		U-0.053	R-19	
<i>Walls, above grade</i>									
Mass	U-0.123	R-7.6 c.i.		U-0.104	R-9.5 c.i.		U-0.580	NR	
Metal building	U-0.094	R-0 + R-9.8 c.i.		U-0.072	R-0 + R-13 c.i.		U-0.162	R-13	
Steel framed	U-0.077	R-13 + R-5 c.i.		U-0.064	R-13 + R-7.5 c.i.		U-0.124	R-13	
Wood framed and other	U-0.089	R-13		U-0.064	R-13 + R-3.8 c.i.		U-0.089	R-13	
<i>Wall, below grade</i>									
Below-grade wall	C-1.140	NR		C-1.140	NR		C-1.140	NR	
<i>Floors</i>									
Mass	U-0.074	R-10 c.i.		U-0.074	R-10 c.i.		U-0.137	R-4.2 c.i.	
Steel joist	U-0.038	R-30		U-0.038	R-30		U-0.052	R-19	
Wood framed and other	U-0.033	R-30		U-0.033	R-30		U-0.051	R-19	
<i>Slab-on-grade floors</i>									
Unheated	F-0.730	NR		F-0.540	R-10 for 24 in.		F-0.730	NR	
Heated	F-0.860	R-15 for 24 in.		F-0.860	R-15 for 24 in.		F-1.020	R-7.5 for 12 in.	
<i>Opaque doors</i>									
Swinging	U-0.370			U-0.370			U-0.370		
Nonswinging	U-0.310			U-0.310			U-0.360		
FENESTRATION	ASSEMBLY MAX. U	ASSEMBLY MAX. SHGC	ASSEMBLY MIN. VT/SHGC	ASSEMBLY MAX. U	ASSEMBLY MAX. SHGC	ASSEMBLY MIN. VT/SHGC	ASSEMBLY MAX. U	ASSEMBLY MAX. SHGC	ASSEMBLY MIN. VT/SHGC
Vertical glazing, 0% to 40% of wall		(for all frame types)			(for all frame types)			(for all frame types)	
Nonmetal framing, all	U-0.31	E&W-0.24, S-0.25, N-0.35	1.10	U-0.33	E&W-0.24, S-0.25, N-0.35	1.10	U-0.83	NR	NR
Metal framing, fixed	U-0.43			U-0.47			U-1.14		
Metal framing, operable	U-0.57			U-0.57			U-1.14		
Metal framing, entrance door	U-0.73			U-0.65			U-0.73		
<i>Skylight, 0% to 3% of roof</i>									
All types	U-0.52	0.33	NR	U-0.52	0.33	NR	U-1.62	NR	NR

* The following definitions apply: c.i. = continuous insulation (see ANSI/ASHRAE/IES Standard 90.1, Section 3.2); NR = no (insulation) requirement; FC = filled cavity (see ANSI/ASHRAE/IES Standard 90.1, Section A2.3.2.5).

** The insulation minimum R-value criteria in this table meet the criteria in Section 701.4.2.1 (7.4.2.1), but it is possible that some assemblies with slightly less insulation minimum R-value will also meet the criteria of Section 701.4.2.1 (7.4.2.1).

a. When using the R-value compliance method for metal building roofs, a thermal spacer block is required (see ANSI/ASHRAE/IES Standard 90.1, Section 3.2).

TABLE E101.4 (TABLE E-4)
(SUPERSEDES TABLE 5.5-4 IN ANSI/ASHRAE/IES STANDARD 90.1)
BUILDING ENVELOPE REQUIREMENTS FOR CLIMATE ZONE 4 (A,B,C)* (I-P)

OPAQUE ELEMENTS	NONRESIDENTIAL			RESIDENTIAL			SEMIHEATED		
	ASSEMBLY MAXIMUM	INSULATION MIN. R-VALUE**		ASSEMBLY MAXIMUM	INSULATION MIN. R-VALUE**		ASSEMBLY MAXIMUM	INSULATION MIN. R-VALUE**	
<i>Roofs</i>									
Insulation entirely above deck	U-0.030	R-35 c.i.		U-0.030	R-35 c.i.		U-0.088	R-11 c.i.	
Metal building ^a	U-0.035	R-11 + R-19 c.i.		U-0.035	R-11 + R-19 c.i.		U-0.078	R-19 + R-6.5 c.i.	
<i>Attic and other roofs</i>	U-0.020	R-60		U-0.020	R-60		U-0.032	R-38	
<i>Walls, above grade</i>									
Mass	U-0.099	R-11.4 c.i.		U-0.086	R-13.3 c.i.		U-0.580	NR	
Metal building	U-0.057	R-11 + R-13 c.i.		U-0.048	R-11 + R-15.8 c.i.		U-0.154	R-19	
Steel framed	U-0.061	R-13 + R-12.5 c.i.		U-0.061	R-13 + R-12.5 c.i.		U-0.118	R-13 + R-3.8 c.i.	
Wood framed and other	U-0.061	R-13 + R-7.5 c.i.		U-0.061	R-13 + R-7.5 c.i.		U-0.085	R-13 + R-3.8 c.i.	
<i>Wall, below grade</i>									
Below-grade wall	C-0.113	R-10.0 c.i.		C-0.087	R-12.5 c.i.		C-1.140	NR	
<i>Floors</i>									
Mass	U-0.054	R-16.7 c.i.		U-0.048	R-18.7 c.i.		U-0.102	R-8.3 c.i.	
Steel joist	U-0.036	R-38		U-0.036	R-38		U-0.049	R-30	
Wood framed and other	U-0.031	R-38		U-0.031	R-38		U-0.048	R-30	
<i>Slab-on-grade floors</i>									
Unheated	F-0.494	R-20 for 48 in.		F-0.494	R-20 for 48 in.		F-0.730	NR	
Heated	F-0.801	R-20 for 48 in.		F-0.654	R-20 full slab		F-0.855	R-20 for 24 in.	
<i>Opaque doors</i>									
Swinging	U-0.352			U-0.352			U-0.352		
Nonswinging	U-0.295			U-0.295			U-0.342		
FENESTRATION	ASSEMBLY MAX. U	ASSEMBLY MAX. SHGC	ASSEMBLY MIN. VT/SHGC	ASSEMBLY MAX. U	ASSEMBLY MAX. SHGC	ASSEMBLY MIN. VT/SHGC	ASSEMBLY MAX. U	ASSEMBLY MAX. SHGC	ASSEMBLY MIN. VT/SHGC
Vertical glazing, 0% to 40% of wall		(for all frame types)			(for all frame types)			(for all frame types)	
Nonmetal framing, all	U-0.29	E&W-0.34, S-0.36, N-0.46	1.10	U-0.29	E&W-0.34, S-0.36, N-0.46	1.10	U-0.48	NR	NR
Metal framing, fixed	U-0.36			U-0.36			U-0.69		
Metal framing, operable	U-0.44			U-0.44			U-0.77		
Metal framing, entrance door	U-0.65			U-0.65			U-0.73		
<i>Skylight, 0% to 3% of roof</i>									
All types	U-0.48	0.38	NR	U-0.48	0.38	NR	U-1.09	NR	NR

* The following definitions apply: c.i. = continuous insulation (see ANSI/ASHRAE/IES Standard 90.1, Section 3.2); NR = no (insulation) requirement.

** The insulation minimum R-value criteria in this table meet the criteria in Section 701.4.2.1 (7.4.2.1), but it is possible that some assemblies with slightly less insulation minimum R-value will also meet the criteria of Section 701.4.2.1 (7.4.2.1).

a. When using the R-value compliance method for metal building roofs, a thermal spacer block is required (see ANSI/ASHRAE/IES Standard 90.1, Section 3.2).

TABLE E101.5 (TABLE E-5)
(SUPERSEDES TABLE 5.5-5 IN ANSI/ASHRAE/IES STANDARD 90.1)
BUILDING ENVELOPE REQUIREMENTS FOR CLIMATE ZONE 5 (A,B,C)* (I-P)

OPAQUE ELEMENTS	NONRESIDENTIAL			RESIDENTIAL			SEMIHEATED		
	ASSEMBLY MAXIMUM	INSULATION MIN. R-VALUE**		ASSEMBLY MAXIMUM	INSULATION MIN. R-VALUE**		ASSEMBLY MAXIMUM	INSULATION MIN. R-VALUE**	
<i>Roofs</i>									
Insulation entirely above deck	U-0.030	R-35 c.i.		U-0.030	R-35 c.i.		U-0.060	R-17 c.i.	
Metal building ^a	U-0.035	R-11 + R-19 c.i.		U-0.035	R-11 + R-19 c.i.		U-0.078	R-19 + R-6.5 c.i.	
<i>Attic and other roofs</i>	U-0.020	R-60		U-0.020	R-60		U-0.032	R-38	
<i>Walls, above grade</i>									
Mass	U-0.086	R-13.3 c.i.		U-0.076	R-15.0 c.i.		U-0.143	R-7.5 c.i.	
Metal building	U-0.048	R-11 + R-15.8 c.i.		U-0.048	R-11 + R-15.8 c.i.		U-0.089	R-11 + R-6.5 c.i.	
Steel framed	U-0.052	R-13 + R-12.5 c.i.		U-0.052	R-13 + R-12.5 c.i.		U-0.080	R-13 + R-5.0 c.i.	
Wood framed and other	U-0.048	R-13 + R-12.5 c.i.		U-0.048	R-13 + R-12.5 c.i.		U-0.085	R-13 + R-3.8 c.i.	
<i>Wall, below grade</i>									
Below-grade wall	C-0.113	R-10.0 c.i.		C-0.087	R-12.5 c.i.		C-1.140	NR	
<i>Floors</i>									
Mass	U-0.054	R-16.7 c.i.		U-0.048	R-18.7 c.i.		U-0.102	R-8.3 c.i.	
Steel joist	U-0.036	R-38		U-0.036	R-38		U-0.049	R-30	
Wood framed and other	U-0.031	R-38		U-0.031	R-38		U-0.048	R-30	
<i>Slab-on-grade floors</i>									
Unheated	F-0.494	R-20 for 48 in.		F-0.485	R-20 for 48 in.		F-0.730	NR	
Heated	F-0.654	R-20 full slab		F-0.654	R-20 full slab		F-0.855	R-20 for 24 in.	
<i>Opaque doors</i>									
Swinging	U-0.352			U-0.352			U-0.352		
Nonswinging	U-0.295			U-0.295			U-0.342		
FENESTRATION	ASSEMBLY MAX. U	ASSEMBLY MAX. SHGC	ASSEMBLY MIN. VT/SHGC	ASSEMBLY MAX. U	ASSEMBLY MAX. SHGC	ASSEMBLY MIN. VT/SHGC	ASSEMBLY MAX. U	ASSEMBLY MAX. SHGC	ASSEMBLY MIN. VT/SHGC
Vertical glazing, 0% to 40% of wall		(for all frame types)			(for all frame types)			(for all frame types)	
Nonmetal framing, all	U-0.29	E&W-0.36, S-0.38, N-0.48	1.10	U-0.29	E&W-0.36, S-0.38, N-0.48	1.10	U-0.43	NR	NR
Metal framing, fixed	U-0.36			U-0.36			U-0.59		
Metal framing, operable	U-0.44			U-0.44			U-0.67		
Metal framing, entrance door	U-0.65			U-0.65			U-0.73		
<i>Skylight, 0% to 3% of roof</i>									
All types	U-0.48	0.38	NR	U-0.48	0.38	NR	U-0.93	NR	NR

* The following definitions apply: c.i. = continuous insulation (see ANSI/ASHRAE/IES Standard 90.1, Section 3.2); NR = no (insulation) requirement.
 **The insulation minimum R-value criteria in this table meet the criteria in Section 701.4.2.1 (7.4.2.1), but it is possible that some assemblies with slightly less insulation minimum R-value will also meet the criteria of Section 701.4.2.1 (7.4.2.1).
 a. When using the R-value compliance method for metal building roofs, a thermal spacer block is required (see ANSI/ASHRAE/IES Standard 90.1, Section 3.2).

**TABLE E101.6 (TABLE E-6)
(SUPERSEDES TABLE 5.5-6 IN ANSI/ASHRAE/IES STANDARD 90.1)
BUILDING ENVELOPE REQUIREMENTS FOR CLIMATE ZONE 6 (A,B)* (I-P)**

OPAQUE ELEMENTS	NONRESIDENTIAL			RESIDENTIAL			SEMIHEATED		
	ASSEMBLY MAXIMUM	INSULATION MIN. R-VALUE**		ASSEMBLY MAXIMUM	INSULATION MIN. R-VALUE**		ASSEMBLY MAXIMUM	INSULATION MIN. R-VALUE**	
<i>Roofs</i>									
Insulation entirely above deck	U-0.030	R-35 c.i.		U-0.030	R-35 c.i.		U-0.060	R-17 c.i.	
Metal building ^a	U-0.029	R-30 + R-11 <i>Ls</i>		U-0.028	R-10 + R-19 + R-13 c.i.		U-0.057	R-10 + R-10 + R-6.5 c.i.	
<i>Attic and other roofs</i>	U-0.020	R-60		U-0.020	R-60		U-0.032	R-38	
<i>Walls, above grade</i>									
Mass	U-0.076	R-15.0 c.i.		U-0.067	R-17.5 c.i.		U-0.143	R-7.5 c.i.	
Metal building	U-0.048	R-11 + R-15.8 c.i.		U-0.048	R-11 + R-15.8 c.i.		U-0.089	R-11 + R-6.5 c.i.	
Steel framed	U-0.047	R-13 + R-15.6 c.i.		U-0.047	R-13 + R-15.6 c.i.		U-0.080	R-13 + R-5 c.i.	
Wood framed and other	U-0.048	R-13 + R-12.5 c.i.		U-0.048	R-13 + R-12.5 c.i.		U-0.085	R-13 + R-3.8 c.i.	
<i>Wall, below grade</i>									
Below-grade wall	C-0.087	R-12.5 c.i.		C-0.060	R-17.5 c.i.		C-0.113	R-10.0 c.i.	
<i>Floors</i>									
Mass	U-0.048	R-18.7 c.i.		U-0.048	R-18.7 c.i.		U-0.083	R-10 c.i.	
Steel joist	U-0.030	R-49.0		U-0.030	R-49		U-0.049	R-30	
Wood framed and other	U-0.026	R-38+ R-7.5 c.i.		U-0.026	R-38 + R-7.5 c.i.		U-0.048	R-30	
<i>Slab-on-grade floors</i>									
Unheated	F-0.485	R-20 for 48 in.		F-0.412	R-15 full slab		F-0.730	NR	
Heated	F-0.654	R-20 full slab		F-0.637	R-20 full slab		F-0.817	R-20 for 48 in.	
<i>Opaque doors</i>									
Swinging	U-0.352			U-0.352			U-0.352		
Nonswinging	U-0.295			U-0.295			U-0.342		
FENESTRATION	ASSEMBLY MAX. U	ASSEMBLY MAX. SHGC	ASSEMBLY MIN. VT/SHGC	ASSEMBLY MAX. U	ASSEMBLY MAX. SHGC	ASSEMBLY MIN. VT/SHGC	ASSEMBLY MAX. U	ASSEMBLY MAX. SHGC	ASSEMBLY MIN. VT/SHGC
Vertical glazing, 0% to 40% of wall		(for all frame types)			(for all frame types)			(for all frame types)	
Nonmetal framing, all	U-0.29	E&W-0.38, S-0.40, N-0.50	1.10	U-0.29	E&W-0.38, S-0.40, N-0.50	1.10	U-0.43	NR	NR
Metal framing, fixed	U-0.34			U-0.34			U-0.48		
Metal framing, operable	U-0.43			U-0.43			U-0.56		
Metal framing, entrance door	U-0.65			U-0.65			U-0.73		
<i>Skylight, 0% to 3% of roof</i>									
All types	U-0.48	0.38	NR	U-0.48	0.38	NR	U-0.81	NR	NR

* The following definitions apply: c.i. = continuous insulation (see ANSI/ASHRAE/IES Standard 90.1, Section 3.2); NR = no (insulation) requirement; *Ls* = liner system (see ANSI/ASHRAE/IES Standard 90.1, Section A2.3.2.4).

** The insulation minimum R-value criteria in this table meet the criteria in Section 701.4.2.1 (7.4.2.1), but it is possible that some assemblies with slightly less insulation minimum R-value will also meet the criteria of Section 701.4.2.1 (7.4.2.1).

a. When using the R-value compliance method for metal building roofs, a thermal spacer block is required (see ANSI/ASHRAE/IES Standard 90.1, Section 3.2).

TABLE E101.7 (TABLE E-7)
(SUPERSEDES TABLE 5.5-7 IN ANSI/ASHRAE/IES STANDARD 90.1)
BUILDING ENVELOPE REQUIREMENTS FOR CLIMATE ZONE 7* (I-P)

OPAQUE ELEMENTS	NONRESIDENTIAL			RESIDENTIAL			SEMIHEATED		
	ASSEMBLY MAXIMUM	INSULATION MIN. R-VALUE**		ASSEMBLY MAXIMUM	INSULATION MIN. R-VALUE**		ASSEMBLY MAXIMUM	INSULATION MIN. R-VALUE**	
<i>Roofs</i>									
Insulation entirely above deck	U-0.027	R-40 c.i.		U-0.027	R-40 c.i.		U-0.037	R-26 c.i.	
Metal building ^a	U-0.028	R-10 + R-19 + R-13 c.i.		U-0.028	R-10 + R-19 + R-13 c.i.		U-0.035	R-11 + R-19 c.i.	
<i>Attic and other roofs</i>	U-0.016	R-71		U-0.016	R-71		U-0.026	R-49	
<i>Walls, above grade</i>									
Mass	U-0.067	R-17.5 c.i.		U-0.067	R-17.5 c.i.		U-0.117	R-9.5 c.i.	
Metal building	U-0.042	R-11 + R-19 c.i.		U-0.042	R-11 + R-19 c.i.		U-0.068	R-11 + R-9.8 c.i.	
Steel framed	U-0.047	R-13 + R-15.6 c.i.		U-0.040	R-13 + R-18.8 c.i.		U-0.061	R-13 + R-12.5 c.i.	
Wood framed and other	U-0.048	R-13 + R-12.5 c.i.		U-0.048	R-13 + R-12.5 c.i.		U-0.061	R-13 + R-7.5 c.i.	
<i>Wall, below grade</i>									
Below-grade wall	C-0.060	R-17.5 c.i.		C-0.060	R-17.5 c.i.		C-0.113	R-10.0 c.i.	
<i>Floors</i>									
Mass	U-0.040	R-23 c.i.		U-0.040	R-23 c.i.		U-0.070	R-12.5 c.i.	
Steel joist	U-0.030	R-49		U-0.030	R-49		U-0.049	R-30	
Wood framed and other	U-0.026	R-38 + R-7.5 c.i.		U-0.026	R-38 + R-7.5 c.i.		U-0.048	R-30	
<i>Slab-on-grade floors</i>									
Unheated	F-0.485	R-20 for 48 in.		F-0.412	R-15 full slab		F-0.730	NR	
Heated	F-0.637	R-20 full slab		F-0.637	R-20 full slab		F-0.817	R-20 for 48 in.	
<i>Opaque doors</i>									
Swinging	U-0.352			U-0.352			U-0.352		
Nonswinging	U-0.295			U-0.295			U-0.295		
FENESTRATION	ASSEMBLY MAX. U	ASSEMBLY MAX. SHGC	ASSEMBLY MIN. VT/SHGC	ASSEMBLY MAX. U	ASSEMBLY MAX. SHGC	ASSEMBLY MIN. VT/SHGC	ASSEMBLY MAX. U	ASSEMBLY MAX. SHGC	ASSEMBLY MIN. VT/SHGC
Vertical glazing, 0% to 40% of wall		(for all frame types)			(for all frame types)			(for all frame types)	
Nonmetal framing, all	U-0.27	E&W-0.43, S-0.45, N-0.55	1.10	U-0.27	E&W-0.43, S-0.45, N-0.55	1.10	U-0.30	NR	NR
Metal framing, fixed	U-0.31			U-0.31			U-0.36		
Metal framing, operable	U-0.38			U-0.38			U-0.42		
Metal framing, entrance door	U-0.65			U-0.65			U-0.73		
<i>Skylight, 0% to 3% of roof</i>									
All types	U-0.48	NR	NR	U-0.48	NR	NR	U-0.81	NR	NR

* The following definitions apply: c.i. = continuous insulation (see ANSI/ASHRAE/IES Standard 90.1, Section 3.2); NR = no (insulation) requirement.
 **The insulation minimum R-value criteria in this table meet the criteria in Section 701.4.2.1 (7.4.2.1), but it is possible that some assemblies with slightly less insulation minimum R-value will also meet the criteria of Section 701.4.2.1 (7.4.2.1).
 a. When using the R-value compliance method for metal building roofs, a thermal spacer block is required (see ANSI/ASHRAE/IES Standard 90.1, Section 3.2).

**TABLE E101.8 (TABLE E-8)
(SUPERSEDES TABLE 5.5-8 IN ANSI/ASHRAE/IES STANDARD 90.1)
BUILDING ENVELOPE REQUIREMENTS FOR CLIMATE ZONE 8* (I-P)**

OPAQUE ELEMENTS	NONRESIDENTIAL			RESIDENTIAL			SEMIHEATED		
	ASSEMBLY MAXIMUM	INSULATION MIN. R-VALUE**		ASSEMBLY MAXIMUM	INSULATION MIN. R-VALUE**		ASSEMBLY MAXIMUM	INSULATION MIN. R-VALUE**	
<i>Roofs</i>									
Insulation entirely above deck	U-0.027	R-40 c.i.		U-0.027	R-40 c.i.		U-0.037	R-26 c.i.	
Metal building ^a	U-0.025	R-19 + R-19 + R-25 c.i.		U-0.025	R-19 + R-19 + R-25 c.i.		U-0.035	R-11 + R-19 c.i.	
<i>Attic and other roofs</i>	U-0.016	R-71		U-0.016	R-71		U-0.026	R-49	
<i>Walls, above grade</i>									
Mass	U-0.046	R-21.0 c.i.		U-0.046	R-21.0 c.i.		U-0.099	R-11.4 c.i.	
Metal building	U-0.037	R-11 + R-22.1 c.i.		U-0.037	R-11 + R-22.1 c.i.		U-0.057	R-11 + R-13 c.i.	
Steel framed	U-0.035	R-13 + R-21.9 c.i.		U-0.035	R-13 + R-21.9 c.i.		U-0.061	R-13 + R-12.5 c.i.	
Wood framed and other	U-0.030	R-13 + R-21.9 c.i.		U-0.030	R-13 + R-21.9 c.i.		U-0.048	R-13 + R-12.5 c.i.	
<i>Wall, below grade</i>									
Below-grade wall	C-0.060	R-17.5 c.i.		C-0.060	R-17.5 c.i.		C-0.113	R-10.0 c.i.	
<i>Floors</i>									
Mass	U-0.036	R-25.1 c.i.		U-0.036	R-25.1 c.i.		U-0.061	R-14.6 c.i.	
Steel joist	U-0.030	R-49		U-0.030	R-49		U-0.049	R-30	
Wood framed and other	U-0.026	R-38 + R-7.5 c.i.		U-0.026	R-38 + R-7.5 c.i.		U-0.031	R-38	
<i>Slab-on-grade floors</i>									
Unheated	F-0.412	R-15 full slab		F-0.403	R-15 full slab		F-0.513	R-20 for 24 in.	
Heated	F-0.637	R-20 full slab		F-0.354	R-25 full slab		F-0.817	R-20 for 48 in.	
<i>Opaque doors</i>									
Swinging	U-0.352			U-0.352			U-0.352		
Nonswinging	U-0.295			U-0.295			U-0.295		
FENESTRATION	ASSEMBLY MAX. U	ASSEMBLY MAX. SHGC	ASSEMBLY MIN. VT/SHGC	ASSEMBLY MAX. U	ASSEMBLY MAX. SHGC	ASSEMBLY MIN. VT/SHGC	ASSEMBLY MAX. U	ASSEMBLY MAX. SHGC	ASSEMBLY MIN. VT/SHGC
Vertical glazing, 0% to 40% of wall		(for all frame types)			(for all frame types)			(for all frame types)	
Nonmetal framing, all	U-0.24	E&W-0.43, S-0.45, N-0.55	1.10	U-0.24	E&W-0.43, S-0.45, N-0.55	1.10	U-0.30	NR	NR
Metal framing, fixed	U-0.28			U-0.28			U-0.36		
Metal framing, operable	U-0.33			U-0.33			U-0.42		
Metal framing, entrance door	U-0.65			U-0.65			U-0.73		
<i>Skylight, 0% to 3% of roof</i>									
All types	U-0.39	NR	NR	U-0.39	NR	NR	U-0.81	NR	NR

* The following definitions apply: c.i. = continuous insulation (see ANSI/ASHRAE/IES Standard 90.1, Section 3.2); NR = no (insulation) requirement.

** The insulation minimum R-value criteria in this table meet the criteria in Section 701.4.2.1 (7.4.2.1), but it is possible that some assemblies with slightly less insulation minimum R-value will also meet the criteria of Section 701.4.2.1 (7.4.2.1).

a. When using the R-value compliance method for metal building roofs, a thermal spacer block is required (see ANSI/ASHRAE/IES Standard 90.1, Section 3.2).

TABLE E101.0 (TABLE E-0)
(SUPERSEDES TABLE 5.5-0 IN ANSI/ASHRAE/IES STANDARD 90.1)
BUILDING ENVELOPE REQUIREMENTS FOR CLIMATE ZONE 0 (A,B)* (SI)

OPAQUE ELEMENTS	NONRESIDENTIAL			RESIDENTIAL			SEMIHEATED		
	ASSEMBLY MAXIMUM	INSULATION MIN. R-VALUE**		ASSEMBLY MAXIMUM	INSULATION MIN. R-VALUE**		ASSEMBLY MAXIMUM	INSULATION MIN. R-VALUE**	
<i>Roofs</i>									
Insulation entirely above deck	U-0.222	R-4.4 c.i.		U-0.184	R-5.3 c.i.		U-1.240	R-0.7 c.i.	
Metal building ^a	U-0.233	R-1.8 + R-3.3 FC		U-0.233	R-1.8 + R-3.3 FC		U-0.653	R-1.8	
<i>Attic and other roofs</i>	U-0.153	R-6.7		U-0.153	R-6.7		U-0.459	R-2.3	
<i>Walls, above grade</i>									
Mass ^b	U-3.293	NR		U-0.857	R-1.0 c.i.		U-3.293	NR	
Metal building	U-0.533	R-0 + R-1.7 ci		U-0.533	R-0 + R-1.7 ci		U-1.998	NR	
Steel framed	U-0.705	R-2.3		U-0.705	R-2.3		U-1.998	NR	
Wood framed and other	U-0.504	R-2.3		U-0.504	R-2.3		U-1.660	NR	
<i>Wall, below grade</i>									
Below-grade wall	C-6.473	NR		C-6.473	NR		C-6.473	NR	
<i>Floors</i>									
Mass	U-1.825	NR		U-1.825	NR		U-1.825	NR	
Steel joist	U-1.986	NR		U-1.986	NR		U-1.986	NR	
Wood framed and other	U-1.599	NR		U-1.599	NR		U-1.599	NR	
<i>Slab-on-grade floors</i>									
Unheated	F-1.264	NR		F-1.264	NR		F-1.264	NR	
Heated	F-1.766	R-1.3 for 300 mm		F-1.766	R-1.3 for 300 mm		F-1.766	R-1.3 for 300 mm	
<i>Opaque doors</i>									
Swinging	U-2.101			U-2.101			U-3.975		
Nonswinging	U-1.760			U-1.760			U-8.233		
FENESTRATION	ASSEMBLY MAX. U	ASSEMBLY MAX. SHGC	ASSEMBLY MIN. VT/SHGC	ASSEMBLY MAX. U	ASSEMBLY MAX. SHGC	ASSEMBLY MIN. VT/SHGC	ASSEMBLY MAX. U	ASSEMBLY MAX. SHGC	ASSEMBLY MIN. VT/SHGC
Vertical glazing, 0% to 40% of wall		(for all frame types)			(for all frame types)			(for all frame types)	
Nonmetal framing (all)	U-1.73	E&W-0.21, N&S-0.22	1.10	U-1.73	E&W-0.21, N&S-0.22	1.10	U-5.02	NR	NR
Metal framing, fixed	U-2.70			U-2.70			U-6.48		
Metal framing, operable	U-3.51			U-3.51			U-6.48		
Metal framing, entrance door	U-4.48			U-4.48			U-5.94		
<i>Skylight, 0% to 3% of roof</i>									
All types	U-4.05	0.33	NR	U-4.05	0.33	NR	U-9.71	NR	NR

* The following definitions apply: c.i. = continuous insulation (see ANSI/ASHRAE/IES Standard 90.1, Section 3.2); NR = no (insulation) requirement; FC = filled cavity (see ANSI/ASHRAE/IES Standard 90.1, Section A2.3.2.5).

** The insulation minimum R-value criteria in this table meet the criteria in Section 701.4.2.1 (7.4.2.1), but it is possible that some assemblies with slightly less insulation minimum R-value will also meet the criteria of Section 701.4.2.1 (7.4.2.1).

a. When using the R-value compliance method for metal building roofs, a thermal spacer block is required (see ANSI/ASHRAE/IES Standard 90.1, Section 3.2).

b. Exception applies for mass walls above grade where the requirement is for a maximum assembly U-0.151 (see ANSI/ASHRAE/IES Standard 90.1, Section 5.5.3.2).

**TABLE E101.1 (TABLE E-1)
(SUPERSEDES TABLE 5.5-1 IN ANSI/ASHRAE/IES STANDARD 90.1)
BUILDING ENVELOPE REQUIREMENTS FOR CLIMATE ZONE 1 (A,B)* (SI)**

OPAQUE ELEMENTS	NONRESIDENTIAL			RESIDENTIAL			SEMIHEATED		
	ASSEMBLY MAXIMUM	INSULATION MIN. R-VALUE**		ASSEMBLY MAXIMUM	INSULATION MIN. R-VALUE**		ASSEMBLY MAXIMUM	INSULATION MIN. R-VALUE**	
<i>Roofs</i>									
Insulation entirely above deck	U-0.273	R-3.5 c.i.		U-0.220	R-4.4 c.i.		U-1.240	R-0.7 c.i.	
Metal building ^a	U-0.233	R-1.8 + R-3.3 FC		U-0.233	R-1.8 + R-3.3 FC		U-0.653	R-1.8	
<i>Attic and other roofs</i>	U-0.153	R-6.7		U-0.153	R-6.7		U-0.459	R-2.3	
<i>Walls, above grade</i>									
Mass ^b	U-3.293	NR		U-0.857	R-1.0 c.i.		U-3.293	NR	
Metal building	U-0.533	R-0 + R-1.7 c.i.		U-0.533	R-0 + R-1.7 c.i.		U-1.998	NR	
Steel framed	U-0.705	R-2.3		U-0.705	R-2.3		U-1.998	NR	
Wood framed and other	U-0.504	R-2.3		U-0.504	R-2.3		U-1.660	NR	
<i>Wall, below grade</i>									
Below-grade wall	C-6.473	NR		C-6.473	NR		C-6.473	NR	
<i>Floors</i>									
Mass	U-1.825	NR		U-1.825	NR		U-1.825	NR	
Steel joist	U-1.986	NR		U-1.986	NR		U-1.986	NR	
Wood framed and other	U-1.599	NR		U-1.599	NR		U-1.599	NR	
<i>Slab-on-grade floors</i>									
Unheated	F-1.264	NR		F-1.264	NR		F-1.264	NR	
Heated	F-1.766	R-1.3 for 300 mm		F-1.766	R-1.3 for 300 mm		F-1.766	R-1.3 for 300 mm	
<i>Opaque doors</i>									
Swinging	U-2.101			U-2.101			U-3.975		
Nonswinging	U-1.760			U-1.760			U-8.233		
FENESTRATION	ASSEMBLY MAX. U	ASSEMBLY MAX. SHGC	ASSEMBLY MIN. VT/SHGC	ASSEMBLY MAX. U	ASSEMBLY MAX. SHGC	ASSEMBLY MIN. VT/SHGC	ASSEMBLY MAX. U	ASSEMBLY MAX. SHGC	ASSEMBLY MIN. VT/SHGC
Vertical glazing, 0% to 40% of wall		(for all frame types)			(for all frame types)			(for all frame types)	
Nonmetal framing, all	U-2.70	E&W-0.24, S-0.25, N-0.35	1.10	U-2.70	E&W-0.24, S-0.25, N-0.35	1.10	U-5.02	NR	NR
Metal framing, fixed	U-3.08			U-3.08			U-6.48		
Metal framing, operable	U-3.51			U-3.51			U-6.48		
Metal framing, entrance door	U-5.94			U-5.94			U-5.94		
<i>Skylight, 0% to 3% of roof</i>									
All types	U-4.05	0.33	NR	U-4.05	0.33	NR	U-9.71	NR	NR

* The following definitions apply: c.i. = continuous insulation (see ANSI/ASHRAE/IES Standard 90.1, Section 3.2); NR = no (insulation) requirement; FC = filled cavity (see ANSI/ASHRAE/IES Standard 90.1, Section A2.3.2.5).

** The insulation minimum R-value criteria in this table meet the criteria in Section 701.4.2.1 (7.4.2.1), but it is possible that some assemblies with slightly less insulation minimum R-value will also meet the criteria of Section 701.4.2.1 (7.4.2.1).

- a. When using the R-value compliance method for metal building roofs, a thermal spacer block is required (see ANSI/ASHRAE/IES Standard 90.1, Section 3.2).
- b. Exception applies for mass walls above grade where the requirement is for a maximum assembly U-0.151 (see ANSI/ASHRAE/IES Standard 90.1, Section 5.5.3.2).

TABLE E101.2 (TABLE E-2)
(SUPERSEDES TABLE 5.5-2 IN ANSI/ASHRAE/IES STANDARD 90.1)
BUILDING ENVELOPE REQUIREMENTS FOR CLIMATE ZONE 2 (A,B)* (SI)

OPAQUE ELEMENTS	NONRESIDENTIAL		RESIDENTIAL		SEMIHEATED				
	ASSEMBLY MAXIMUM	INSULATION MIN. R-VALUE**	ASSEMBLY MAXIMUM	INSULATION MIN. R-VALUE**	ASSEMBLY MAXIMUM	INSULATION MIN. R-VALUE**			
<i>Roofs</i>									
Insulation entirely above deck	U-0.220	R-4.4 c.i.	U-0.220	R-4.4 c.i.	U-0.982	R-0.9 c.i.			
Metal building ^a	U-0.233	R-1.8 + R-3.3 FC	U-0.233	R-1.8 + R-3.3 FC	U-0.545	R-2.8			
<i>Attic and other roofs</i>	U-0.153	R-6.7	U-0.153	R-6.7	U-0.300	R-3.3			
<i>Walls, above grade</i>									
Mass ^b	U-0.857	R-1.0 c.i.	U-0.701	R-1.3 c.i.	U-3.293	NR			
Metal building	U-0.533	R-0 + R-1.7 c.i.	U-0.533	R-0 + R-1.7 c.i.	U-0.920	R-2.3			
Steel framed	U-0.479	R-2.3 + R-0.7 c.i.	U-0.365	R-2.3 + R-1.3 c.i.	U-0.705	R-2.3			
Wood framed and other	U-0.504	R-2.3	U-0.504	R-2.3	U-0.504	R-2.3			
<i>Wall, below grade</i>									
Below-grade wall	C-6.473	NR	C-6.473	NR	C-6.473	NR			
<i>Floors</i>									
Mass	U-0.606	R-1.1	U-0.496	R-1.5	U-1.825	NR			
Steel joist	U-0.214	R-5.3	U-0.214	R-5.3	U-0.390	R-2.3			
Wood framed and other	U-0.188	R-5.3	U-0.188	R-5.3	U-0.376	R-2.3			
<i>Slab-on-grade floors</i>									
Unheated	F-1.264	NR	F-1.264	NR	F-1.264	NR			
Heated	F-1.558	R-1.8 for 600 mm	F-1.489	R-2.6 for 600 mm	F-1.766	R-1.3 for 300 mm			
<i>Opaque doors</i>									
Swinging	U-2.101		U-2.101		U-3.975				
Nonswinging	U-1.760		U-1.760		U-8.233				
FENESTRATION	ASSEMBLY MAX. U	ASSEMBLY MAX. SHGC	ASSEMBLY MIN. VT/SHGC	ASSEMBLY MAX. U	ASSEMBLY MAX. SHGC	ASSEMBLY MIN. VT/SHGC	ASSEMBLY MAX. U	ASSEMBLY MAX. SHGC	ASSEMBLY MIN. VT/SHGC
Vertical glazing, 0% to 40% of wall		(for all frame types)			(for all frame types)			(for all frame types)	
Nonmetal framing, all	U-2.00	E&W-0.24, S-0.25, N-0.35	1.10	U-2.00	E&W-0.24, S-0.25, N-0.35	1.10	U-5.02	NR	NR
Metal framing, fixed	U-2.91			U-2.91			U-6.48		
Metal framing, operable	U-3.51			U-3.51			U-6.48		
Metal framing, entrance door	U-4.48			U-4.15			U-4.48		
<i>Skylight, 0% to 3% of roof</i>									
All types	U-3.51	0.35	NR	U-3.51	0.33	NR	U-9.71	NR	NR

* The following definitions apply: c.i. = continuous insulation (see ANSI/ASHRAE/IES Standard 90.1, Section 3.2); NR = no (insulation) requirement; FC = filled cavity (see ANSI/ASHRAE/IES Standard 90.1, Section A2.3.2.5).

**The insulation minimum R-value criteria in this table meet the criteria in Section 701.4.2.1 (7.4.2.1), but it is possible that some assemblies with slightly less insulation minimum R-value will also meet the criteria of Section 701.4.2.1 (7.4.2.1).

- a. When using the R-value compliance method for metal building roofs, a thermal spacer block is required (see ANSI/ASHRAE/IES Standard 90.1, Section 3.2).
- b. Exception applies for mass walls above grade where the requirement is for a maximum assembly U-0.151 (see ANSI/ASHRAE/IES Standard 90.1, Section 5.5.3.2).

TABLE E101.3 (TABLE E-3)
(SUPERSEDES TABLE 5.5-3 IN ANSI/ASHRAE/IES STANDARD 90.1)
BUILDING ENVELOPE REQUIREMENTS FOR CLIMATE ZONE 3 (A,B,C)* (SI)

OPAQUE ELEMENTS	NONRESIDENTIAL			RESIDENTIAL			SEMIHEATED		
	ASSEMBLY MAXIMUM	INSULATION MIN. R-VALUE**		ASSEMBLY MAXIMUM	INSULATION MIN. R-VALUE**		ASSEMBLY MAXIMUM	INSULATION MIN. R-VALUE**	
<i>Roofs</i>									
Insulation entirely above deck	U-0.220	R-4.4 c.i.		U-0.220	R-4.4 c.i.		U-0.677	R-1.3 c.i.	
Metal building ^a	U-0.233	R-1.8 + R-3.3 FC		U-0.233	R-1.8 + R-3.3 FC		U-0.545	R-2.8	
<i>Attic and other roofs</i>	U-0.153	R-6.7		U-0.153	R-6.7		U-0.300	R-3.3	
<i>Walls, above grade</i>									
Mass	U-0.701	R-1.3 c.i.		U-0.592	R-1.7 c.i.		U-3.293	NR	
Metal building	U-0.533	R-0 + R-1.7 c.i.		U-0.409	R-0 + R-2.3 c.i.		U-0.920	R-2.3	
Steel framed	U-0.435	R-2.3 + R-0.9 c.i.		U-0.365	R-2.3 + R-1.3 c.i.		U-0.705	R-2.3	
Wood framed and other	U-0.504	R-2.3		U-0.365	R-2.3 + R-0.7 c.i.		U-0.504	R-2.3	
<i>Wall, below grade</i>									
Below-grade wall	C-6.473	NR		C-6.473	NR		C-6.473	NR	
<i>Floors</i>									
Mass	U-0.420	R-1.8 c.i.		U-0.420	R-1.8 c.i.		U-0.780	R-0.7 c.i.	
Steel joist	U-0.214	R-5.3		U-0.214	R-5.3		U-0.296	R-3.3	
Wood framed and other	U-0.188	R-5.3		U-0.188	R-5.3		U-0.288	R-3.3	
<i>Slab-on-grade floors</i>									
Unheated	F-1.264	NR		F-0.935	R-1.8 for 600 mm		F-1.264	NR	
Heated	F-1.489	R-2.6 for 600 mm		F-1.489	R-2.6 for 600 mm		F-1.766	R-1.3 for 300 mm	
<i>Opaque doors</i>									
Swinging	U-2.101			U-2.101			U-2.101		
Nonswinging	U-1.760			U-1.760			U-2.044		
FENESTRATION	ASSEMBLY MAX. U	ASSEMBLY MAX. SHGC	ASSEMBLY MIN. VT/SHGC	ASSEMBLY MAX. U	ASSEMBLY MAX. SHGC	ASSEMBLY MIN. VT/SHGC	ASSEMBLY MAX. U	ASSEMBLY MAX. SHGC	ASSEMBLY MIN. VT/SHGC
Vertical glazing, 0% to 40% of wall		(for all frame types)			(for all frame types)			(for all frame types)	
Nonmetal framing, all	U-1.78	E&W-0.24, S-0.25, N-0.35	1.10	U-1.89	E&W-0.24, S-0.25, N-0.35	1.10	U-4.69	NR	NR
Metal framing, fixed	U-2.43			U-2.64			U-6.48		
Metal framing, operable	U-3.24			U-3.24			U-6.48		
Metal framing, entrance door	U-4.15			U-3.67			U-4.15		
<i>Skylight, 0% to 3% of roof</i>									
All types	U-2.97	0.33	NR	U-2.97	0.33	NR	U-9.17	NR	NR

* The following definitions apply: c.i. = continuous insulation (see ANSI/ASHRAE/IES Standard 90.1, Section 3.2); NR = no (insulation) requirement; FC = filled cavity (see ANSI/ASHRAE/IES Standard 90.1, Section A2.3.2.5).

** The insulation minimum R-value criteria in this table meet the criteria in Section 701.4.2.1 (7.4.2.1), but it is possible that some assemblies with slightly less insulation minimum R-value will also meet the criteria of Section 701.4.2.1 (7.4.2.1).

a. When using the R-value compliance method for metal building roofs, a thermal spacer block is required (see ANSI/ASHRAE/IES Standard 90.1, Section 3.2).

TABLE E101.4 (TABLE E-4)
(SUPERSEDES TABLE 5.5-4 IN ANSI/ASHRAE/IES STANDARD 90.1)
BUILDING ENVELOPE REQUIREMENTS FOR CLIMATE ZONE 4 (A,B,C)* (SI)

OPAQUE ELEMENTS	NONRESIDENTIAL		RESIDENTIAL		SEMIHEATED				
	ASSEMBLY MAXIMUM	INSULATION MIN. R-VALUE**	ASSEMBLY MAXIMUM	INSULATION MIN. R-VALUE**	ASSEMBLY MAXIMUM	INSULATION MIN. R-VALUE**			
<i>Roofs</i>									
Insulation entirely above deck	U-0.173	R-6.2 c.i.	U-0.173	R-6.2 c.i.	U-0.502	R-1.9 c.i.			
Metal building ^a	U-0.200	R-1.9 + R-3.3 c.i.	U-0.200	R-1.9 + R-3.3 c.i.	U-0.442	R-3.3 + R-1.1 c.i.			
<i>Attic and other roofs</i>	U-0.113	R-10.6	U-0.113	R-10.6	U-0.183	R-6.7			
<i>Walls, above grade</i>									
Mass	U-0.561	R-2.0 c.i.	U-0.486	R-2.3 c.i.	U-3.294	NR			
Metal building	U-0.324	R-1.9 + R-2.3 c.i.	U-0.270	R-1.9 + R-2.8 c.i.	U-0.874	R-3.3			
Steel framed	U-0.345	R-2.3 + R-2.2 c.i.	U-0.345	R-2.3 + R-2.2 c.i.	U-0.669	R-2.3 + R-0.7 c.i.			
Wood framed and other	U-0.345	R-2.3 + R-1.3 c.i.	U-0.345	R-2.3 + R-1.3 c.i.	U-0.480	R-2.3 + R-0.7 c.i.			
<i>Wall, below grade</i>									
Below-grade wall	C-0.642	R-1.8 c.i.	C-0.496	R-2.2 c.i.	C-6.475	NR			
<i>Floors</i>									
Mass	U-0.308	R-2.9 c.i.	U-0.275	R-3.3 c.i.	U-0.577	R-1.5 c.i.			
Steel joist	U-0.205	R-6.7	U-0.205	R-6.7	U-0.281	R-5.3			
Wood framed and other	U-0.178	R-6.7	U-0.178	R-6.7	U-0.275	R-5.3			
<i>Slab-on-grade floors</i>									
Unheated	F-0.855	R-3.5 for 1200 mm	F-0.855	R-3.5 for 1200 mm	F-1.264	NR			
Heated	F-1.386	R-3.5 for 1200 mm	F-1.131	R-3.5 full slab	F-1.480	R-3.5 for 600 mm			
<i>Opaque doors</i>									
Swinging	U-1.997		U-1.997		U-1.997				
Nonswinging	U-1.673		U-1.673		U-1.943				
FENESTRATION	ASSEMBLY MAX. U	ASSEMBLY MAX. SHGC	ASSEMBLY MIN. VT/SHGC	ASSEMBLY MAX. U	ASSEMBLY MAX. SHGC	ASSEMBLY MIN. VT/SHGC	ASSEMBLY MAX. U	ASSEMBLY MAX. SHGC	ASSEMBLY MIN. VT/SHGC
Vertical glazing, 0% to 40% of wall		(for all frame types)			(for all frame types)			(for all frame types)	
Nonmetal framing, all	U-1.67	E&W-0.34, S-0.36, N-0.46	1.10	U-1.67	E&W-0.34, S-0.36, N-0.46	1.10	U-2.75	NR	NR
Metal framing, fixed	U-2.05			U-2.05			U-3.94		
Metal framing, operable	U-2.48			U-2.48			U-4.37		
Metal framing, entrance door	U-3.67			U-3.67			U-4.15		
<i>Skylight, 0% to 3% of roof</i>									
All types	U-2.70	0.38	NR	U-2.70	0.38	NR	U-6.21	NR	NR

* The following definitions apply: c.i. = continuous insulation (see ANSI/ASHRAE/IES Standard 90.1, Section 3.2); NR = no (insulation) requirement.
 **The insulation minimum R-value criteria in this table meet the criteria in Section 701.4.2.1 (7.4.2.1), but it is possible that some assemblies with slightly less insulation minimum R-value will also meet the criteria of Section 701.4.2.1 (7.4.2.1).
 a. When using the R-value compliance method for metal building roofs, a thermal spacer block is required (see ANSI/ASHRAE/IES Standard 90.1, Section 3.2).

**TABLE E101.5 (TABLE E-5)
(SUPERSEDES TABLE 5.5-5 IN ANSI/ASHRAE/IES STANDARD 90.1)
BUILDING ENVELOPE REQUIREMENTS FOR CLIMATE ZONE 5 (A, B, C)* (SI)**

OPAQUE ELEMENTS	NONRESIDENTIAL			RESIDENTIAL			SEMIHEATED		
	ASSEMBLY MAXIMUM	INSULATION MIN. R-VALUE**		ASSEMBLY MAXIMUM	INSULATION MIN. R-VALUE**		ASSEMBLY MAXIMUM	INSULATION MIN. R-VALUE**	
<i>Roofs</i>									
Insulation entirely above deck	U-0.173	R-6.2 c.i.		U-0.173	R-6.2 c.i.		U-0.340	R-3.0 c.i.	
Metal building ^a	U-0.200	R-1.9 + R-3.3 c.i.		U-0.200	R-1.9 + R-3.3 c.i.		U-0.442	R-3.3 + R-1.1 c.i.	
<i>Attic and other roofs</i>	U-0.113	R-10.6		U-0.113	R-10.6		U-0.183	R-6.7	
<i>Walls, above grade</i>									
Mass	U-0.486	R-2.3 c.i.		U-0.432	R-2.6 c.i.		U-0.815	R-1.3 c.i.	
Metal building	U-0.270	R-1.9 + R-2.8 c.i.		U-0.270	R-1.9 + R-2.8 c.i.		U-0.507	R-1.9 + R-1.1 c.i.	
Steel framed	U-0.297	R-2.3 + R-2.2 c.i.		U-0.297	R-2.3 + R-2.2 c.i.		U-0.453	R-2.3 + R-0.9 c.i.	
Wood framed and other	U-0.275	R-2.3 + R-2.2 c.i.		U-0.275	R-2.3 + R-2.2 c.i.		U-0.480	R-2.3 + R-0.7 c.i.	
<i>Wall, below grade</i>									
Below-grade wall	C-0.642	R-1.8 c.i.		C-0.496	R-2.2 c.i.		C-6.475	NR	
<i>Floors</i>									
Mass	U-0.308	R-2.9 c.i.		U-0.275	R-3.3 c.i.		U-0.577	R-1.5 c.i.	
Steel joist	U-0.205	R-6.7		U-0.205	R-6.7		U-0.281	R-5.3	
Wood framed and other	U-0.178	R-6.7		U-0.178	R-6.7		U-0.275	R-5.3	
<i>Slab-on-grade floors</i>									
Unheated	F-0.855	R-3.5 for 1200 mm		F-0.839	R-3.5 for 1200 mm		F-1.264	NR	
Heated	F-1.131	R-3.5 full slab		F-1.131	R-3.5 full slab		F-1.480	R-3.5 for 600 mm	
<i>Opaque doors</i>									
Swinging	U-1.997			U-1.997			U-1.997		
Nonswinging	U-1.673			U-1.673			U-1.943		
FENESTRATION	ASSEMBLY MAX. U	ASSEMBLY MAX. SHGC	ASSEMBLY MIN. VT/SHGC	ASSEMBLY MAX. U	ASSEMBLY MAX. SHGC	ASSEMBLY MIN. VT/SHGC	ASSEMBLY MAX. U	ASSEMBLY MAX. SHGC	ASSEMBLY MIN. VT/SHGC
Vertical glazing, 0% to 40% of wall		(for all frame types)			(for all frame types)			(for all frame types)	
Nonmetal framing, all	U-1.67	E&W-0.36, S-0.38, N-0.48	1.10	U-1.67	E&W-0.36, S-0.38, N-0.48	1.10	U-2.43	NR	NR
Metal framing, fixed	U-2.05			U-2.05			U-3.35		
Metal framing, operable	U-2.48			U-2.48			U-3.78		
Metal framing, entrance door	U-3.67			U-3.67			U-4.15		
<i>Skylight, 0% to 3% of roof</i>									
All types	U-2.70	0.38	NR	U-2.70	0.38	NR	U-5.29	NR	NR

* The following definitions apply: c.i. = continuous insulation (see ANSI/ASHRAE/IES Standard 90.1, Section 3.2); NR = no (insulation) requirement.

** The insulation minimum R-value criteria in this table meet the criteria in Section 701.4.2.1 (7.4.2.1), but it is possible that some assemblies with slightly less insulation minimum R-value will also meet the criteria of Section 701.4.2.1 (7.4.2.1).

a. When using the R-value compliance method for metal building roofs, a thermal spacer block is required (see ANSI/ASHRAE/IES Standard 90.1, Section 3.2).

TABLE E101.6 (TABLE E-6)
(SUPERSEDES TABLE 5.5-6 IN ANSI/ASHRAE/IES STANDARD 90.1)
BUILDING ENVELOPE REQUIREMENTS FOR CLIMATE ZONE 6 (A,B)* (SI)

OPAQUE ELEMENTS	NONRESIDENTIAL		RESIDENTIAL		SEMIHEATED				
	ASSEMBLY MAXIMUM	INSULATION MIN. R-VALUE**	ASSEMBLY MAXIMUM	INSULATION MIN. R-VALUE**	ASSEMBLY MAXIMUM	INSULATION MIN. R-VALUE**			
<i>Roofs</i>									
Insulation entirely above deck	U-0.173	R-6.2 c.i.	U-0.173	R-6.2 c.i.	U-0.340	R-3.0 c.i.			
Metal building ^a	U-0.167	R-5.3 + R-1.9 <i>Ls</i>	U-0.156	R-1.8 + R-3.3 + R-2.3 c.i.	U-0.324	R-1.8 + R-1.8 + R-1.1 c.i.			
<i>Attic and other roofs</i>	U-0.113	R-10.6	U-0.113	R-10.6	U-0.183	R-6.7			
<i>Walls, above grade</i>									
Mass	U-0.432	R-2.6 c.i.	U-0.383	R-3.1 c.i.	U-0.815	R-1.3 c.i.			
Metal building	U-0.270	R-1.9 + R-2.8 c.i.	U-0.270	R-1.9 + R-2.8 c.i.	U-0.507	R-1.9 + R-1.1 c.i.			
Steel framed	U-0.264	R-2.3 + R-2.7 c.i.	U-0.264	R-2.3 + R-2.7 c.i.	U-0.453	R-2.3 + R-0.9 c.i.			
Wood framed and other	U-0.275	R-2.3 + R-2.2 c.i.	U-0.275	R-2.3 + R-2.2 c.i.	U-0.480	R-2.3 + R-0.7 c.i.			
<i>Wall, below grade</i>									
Below-grade wall	C-0.496	R-2.2 c.i.	C-0.340	R-3.1 c.i.	C-0.642	R-1.8 c.i.			
<i>Floors</i>									
Mass	U-0.275	R-3.3 c.i.	U-0.275	R-3.3 c.i.	U-0.469	R-1.8 c.i.			
Steel joist	U-0.173	R-8.6	U-0.173	R-8.6	U-0.281	R-5.3			
Wood framed and other	U-0.146	R-6.7 + R-1.3 c.i.	U-0.146	R-6.7 + R-1.3 c.i.	U-0.275	R-5.3			
<i>Slab-on-grade floors</i>									
Unheated	F-0.839	R-3.5 for 1200 mm	F-0.714	R-2.6 full slab	F-1.264	NR			
Heated	F-1.131	R-3.5 full slab	F-1.103	R-3.5 full slab	F-1.414	R-3.5 for 1200 mm			
<i>Opaque doors</i>									
Swinging	U-1.997		U-1.997		U-1.997				
Nonswinging	U-1.673		U-1.673		U-1.943				
FENESTRATION	ASSEMBLY MAX. U	ASSEMBLY MAX. SHGC	ASSEMBLY MIN. VT/SHGC	ASSEMBLY MAX. U	ASSEMBLY MAX. SHGC	ASSEMBLY MIN. VT/SHGC	ASSEMBLY MAX. U	ASSEMBLY MAX. SHGC	ASSEMBLY MIN. VT/SHGC
Vertical glazing, 0% to 40% of wall		(for all frame types)			(for all frame types)			(for all frame types)	
Nonmetal framing, all	U-1.62	E&W-0.38, S-0.40, N-0.50	1.10	U-1.62	E&W-0.38, S-0.40, N-0.50	1.10	U-2.43	NR	NR
Metal framing, fixed	U-1.94			U-1.94			U-2.75		
Metal framing, operable	U-2.43			U-2.43			U-3.18		
Metal framing, entrance door	U-3.67			U-3.67			U-4.15		
<i>Skylight, 0% to 3% of roof</i>									
All types	U-2.70	0.38	NR	U-2.70	0.38	NR	U-4.59	NR	NR

* The following definitions apply: c.i. = continuous insulation (ANSI/ASHRAE/IES Standard 90.1, see Section 3.2); NR = no (insulation) requirement; *Ls* = liner system (see ANSI/ASHRAE/IES Standard 90.1, Section A2.3.2.4).

**The insulation minimum R-value criteria in this table meet the criteria in Section 701.4.2.1 (7.4.2.1), but it is possible that some assemblies with slightly less insulation minimum R-value will also meet the criteria of Section 701.4.2.1 (7.4.2.1).

a. When using the R-value compliance method for metal building roofs, a thermal spacer block is required (see ANSI/ASHRAE/IES Standard 90.1, Section 3.2).

**TABLE E101.7 (TABLE E-7)
(SUPERSEDES TABLE 5.5-7 IN ANSI/ASHRAE/IES STANDARD 90.1)
BUILDING ENVELOPE REQUIREMENTS FOR CLIMATE ZONE 7* (SI)**

OPAQUE ELEMENTS	NONRESIDENTIAL			RESIDENTIAL			SEMIHEATED		
	ASSEMBLY MAXIMUM	INSULATION MIN. R-VALUE**		ASSEMBLY MAXIMUM	INSULATION MIN. R-VALUE**		ASSEMBLY MAXIMUM	INSULATION MIN. R-VALUE**	
<i>Roofs</i>									
Insulation entirely above deck	U-0.151	R-7.0 c.i.		U-0.151	R-7.0 c.i.		U-0.210	R-4.6 c.i.	
Metal building ^a	U-0.156	R-1.8 + R-3.3 + R-2.3 c.i.		U-0.156	R-1.8 + R-3.3 + R-2.3 c.i.		U-0.200	R-1.9 + R-3.3 c.i.	
<i>Attic and other roofs</i>	U-0.092	R-12.5		U-0.092	R-12.5		U-0.146	R-8.6	
<i>Walls, above grade</i>									
Mass	U-0.383	R-3.1 c.i.		U-0.383	R-3.1 c.i.		U-0.664	R-1.7 c.i.	
Metal building	U-0.237	R-1.9 + R-3.3 c.i.		U-0.237	R-1.9 + R-3.3 c.i.		U-0.389	R-1.9 + R-1.7 c.i.	
Steel framed	U-0.264	R-2.3 + R-2.7 c.i.		U-0.227	R-2.3 + R-3.3 c.i.		U-0.345	R-2.3 + R-2.2 c.i.	
Wood framed and other	U-0.275	R-2.3 + R-2.2 c.i.		U-0.275	R-2.3 + R-2.2 c.i.		U-0.345	R-2.3 + R-1.3 c.i.	
<i>Wall, below grade</i>									
Below-grade wall	C-0.340	R-3.1 c.i.		C-0.340	R-3.1 c.i.		C-0.642	R-1.8 c.i.	
<i>Floors</i>									
Mass	U-0.227	R-4.1 c.i.		U-0.227	R-4.1 c.i.		U-0.399	R-2.2 c.i.	
Steel joist	U-0.173	R-8.6		U-0.173	R-8.6		U-0.281	R-5.3	
Wood framed and other	U-0.146	R-6.7+ R-1.3 c.i.		U-0.146	R-6.7 + R-1.3 c.i.		U-0.275	R-5.3	
<i>Slab-on-grade floors</i>									
Unheated	F-0.839	R-3.5 for 1200 mm		F-0.714	R-2.6 full slab		F-1.264	NR	
Heated	F-1.103	R-3.5 full slab		F-1.103	R-3.5 full slab		F-1.414	R-3.5 for 1200 mm	
<i>Opaque doors</i>									
Swinging	U-1.997			U-1.997			U-1.997		
Nonswinging	U-1.673			U-1.673			U-1.673		
FENESTRATION	ASSEMBLY MAX. U	ASSEMBLY MAX. SHGC	ASSEMBLY MIN. VT/SHGC	ASSEMBLY MAX. U	ASSEMBLY MAX. SHGC	ASSEMBLY MIN. VT/SHGC	ASSEMBLY MAX. U	ASSEMBLY MAX. SHGC	ASSEMBLY MIN. VT/SHGC
Vertical glazing, 0% to 40% of wall		(for all frame types)			(for all frame types)			(for all frame types)	
Nonmetal framing, all	U-1.51	E&W-0.43, S-0.45, N-0.55	1.10	U-1.51	E&W-0.43, S-0.45, N-0.55	1.10	U-1.73	NR	NR
Metal framing, fixed	U-1.78			U-1.78			U-2.05		
Metal framing, operable	U-2.16			U-2.16			U-2.37		
Metal framing, entrance door	U-3.67			U-3.67			U-4.15		
<i>Skylight, 0% to 3% of roof</i>									
All types	U-2.70	NR	NR	U-2.70	NR	NR	U-4.59	NR	NR

* The following definitions apply: c.i. = continuous insulation (see ANSI/ASHRAE/IES Standard 90.1, Section 3.2); NR = no (insulation) requirement.

** The insulation minimum R-value criteria in this table meet the criteria in Section 701.4.2.1 (7.4.2.1), but it is possible that some assemblies with slightly less insulation minimum R-value will also meet the criteria of Section 701.4.2.1 (7.4.2.1).

a. When using the R-value compliance method for metal building roofs, a thermal spacer block is required (see ANSI/ASHRAE/IES Standard 90.1, Section 3.2).

TABLE E101.8 (TABLE E-8)
(SUPERSEDES TABLE 5.5-8 IN ANSI/ASHRAE/IES STANDARD 90.1)
BUILDING ENVELOPE REQUIREMENTS FOR CLIMATE ZONE 8* (S1)

OPAQUE ELEMENTS	NONRESIDENTIAL			RESIDENTIAL			SEMIHEATED		
	ASSEMBLY MAXIMUM	INSULATION MIN. R-VALUE**		ASSEMBLY MAXIMUM	INSULATION MIN. R-VALUE**		ASSEMBLY MAXIMUM	INSULATION MIN. R-VALUE**	
<i>Roofs</i>									
Insulation entirely above deck	U-0.151	R-7.0 c.i.		U-0.151	R-7.0 c.i.		U-0.210	R-4.6 c.i.	
Metal building ^a	U-0.140	R-3.3 + R-3.3 + R-4.4 c.i.		U-0.140	R-3.3 + R-3.3 + R-4.4 c.i.		U-0.200	R-1.9 + R-3.3 c.i.	
<i>Attic and other roofs</i>	U-0.092	R-12.5		U-0.092	R-12.5		U-0.146	R-8.6	
<i>Walls, above grade</i>									
Mass	U-0.259	R-3.7 c.i.		U-0.259	R-3.7 c.i.		U-0.561	R-2.0 c.i.	
Metal building	U-0.210	R-1.9 + R-3.9 c.i.		U-0.210	R-1.9 + R-3.9 c.i.		U-0.324	R-1.9 + R-2.3 c.i.	
Steel framed	U-0.200	R-2.3 + R-3.9 c.i.		U-0.200	R-2.3 + R-3.9 c.i.		U-0.345	R-2.3 + R-2.2 c.i.	
Wood framed and other	U-0.173	R-2.3 + R-3.9 c.i.		U-0.173	R-2.3 + R-3.9 c.i.		U-0.275	R-2.3 + R-2.2 c.i.	
<i>Wall, below grade</i>									
Below-grade wall	C-0.340	R-3.1 c.i.		C-0.340	R-3.1 c.i.		C-0.642	R-1.8 c.i.	
<i>Floors</i>									
Mass	U-0.205	R-4.4 c.i.		U-0.205	R-4.4 c.i.		U-0.345	R-2.6 c.i.	
Steel joist	U-0.173	R-8.6		U-0.173	R-8.6		U-0.281	R-5.3	
Wood framed and other	U-0.146	R-6.7 + R-1.3 c.i.		U-0.146	R-6.7 + R-1.3 c.i.		U-0.178	R-6.7	
<i>Slab-on-grade floors</i>									
Unheated	F-0.714	R-2.6 full slab		F-0.697	R-2.6 full slab		F-0.888	R-3.5 for 600 mm	
Heated	F-1.103	R-3.5 full slab		F-0.613	R-4.4 full slab		F-1.414	R-3.5 for 1200 mm	
<i>Opaque doors</i>									
Swinging	U-1.997			U-1.997			U-1.997		
Nonswinging	U-1.673			U-1.673			U-1.673		
FENESTRATION	ASSEMBLY MAX. U	ASSEMBLY MAX. SHGC	ASSEMBLY MIN. VT/SHGC	ASSEMBLY MAX. U	ASSEMBLY MAX. SHGC	ASSEMBLY MIN. VT/SHGC	ASSEMBLY MAX. U	ASSEMBLY MAX. SHGC	ASSEMBLY MIN. VT/SHGC
Vertical glazing, 0% to 40% of wall		(for all frame types)			(for all frame types)			(for all frame types)	
Nonmetal framing, all	U-1.35	E&W-0.43, S-0.45, N-0.55	1.10	U-1.35	E&W-0.43, S-0.45, N-0.55	1.10	U-1.73	NR	NR
Metal framing, fixed	U-1.56			U-1.56			U-2.05		
Metal framing, operable	U-1.89			U-1.89			U-2.37		
Metal framing, entrance door	U-3.67			U-3.67			U-4.15		
<i>Skylight, 0% to 3% of roof</i>									
All types	U-2.21	NR	NR	U-2.21	NR	NR	U-4.59	NR	NR

* The following definitions apply: c.i. = continuous insulation (see ANSI/ASHRAE/IES Standard 90.1, Section 3.2); NR = no (insulation) requirement.
 **The insulation minimum R-value criteria in this table meet the criteria in Section 701.4.2.1 (7.4.2.1), but it is possible that some assemblies with slightly less insulation minimum R-value will also meet the criteria of Section 701.4.2.1 (7.4.2.1).
 a. When using the R-value compliance method for metal building roofs, a thermal spacer block is required (see ANSI/ASHRAE/IES Standard 90.1, Section 3.2).

INFORMATIVE APPENDIX F

INTEGRATED DESIGN

(This appendix is not part of this code. It is merely informative and does not contain requirements necessary for conformance to the code. It has not been processed according to the ANSI requirements for a code and may contain material that has not been subject to public review or a consensus process. Unresolved objectors on informative material are not offered the right to appeal at ASHRAE or ANSI.)

SECTION F101 (F1) Integrated Design Process/Integrated Project Delivery

Integrated design, and related concepts such as *integrated project delivery* and integrative design, leverages early stakeholder collaboration, through the sharing of knowledge and expertise among project team members, to develop stronger, more balanced design solutions. This *integrated design process* stands in contrast to traditional design methods, where there is limited use of the skills and knowledge of all stakeholders. An *integrated design process* provides increased predictability of project outcomes earlier and enables the construction of *high-performance green buildings* that consume fewer resources and provide better comfort and functionality.

Integrated design introduces major issues and key participants into the project early, where more opportunities occur for creative problem solving. The complex interactions of sophisticated building systems require early coordination to maximize their effectiveness and output. Early team building and goal setting may also reduce total project costs. The collaborative process can inform *building envelope*, mechanical, electrical, plumbing, and other building system design. The later in the design process that systems are introduced, the more expensive their implementation will be. Information technology can also be a valuable asset in increasing predictability of outcomes earlier in the project and is recommended for all integrated teams.

In contrast with a linear design process, which addresses problems sequentially, an integrated process approaches each problem with input from the various viewpoints of the participants and the domains they represent, circling back after each design decision to collectively evaluate the impact on all stakeholders. This process acknowledges the complex interdependency of building systems and their relationship to resource consumption and occupant well being.

Several existing, and currently evolving, models for collaboration should be considered, including *ASHRAE Handbook—HVAC Applications*, Chapter 57; the MTS 1.0 WSIP Guide, *Whole Systems Integrated Process Guide for Sustainable Buildings and Communities*; and *Integrated Project Delivery: A Guide* by the AIA and AIA California Council.

Project-specific integrated design and/or *integrated project delivery* processes should be determined with full participation of the stakeholder team. What works for one project may not be the best approach for the next. Additionally, the team should collectively identify the performance standards

and the associated metrics by which project success will be evaluated. Design charrettes of varying duration may be an effective tool to consider, though ultimately it is the responsibility of the stakeholder team to determine the process that will best fit a specific problem or project.

F101.1 (F1.1) Design Charrette. The following outlines one type of design charrette process that resulted in a successful integrated design. A charrette process can be initiated at the initial stages of building design, and the members of the process should include all stakeholders.

F101.1.1 (F1.1.1) Charrette Process. Experienced personnel representing each specialty should participate in the charrette process. A discussion of all systems and all items that affect the *integrated design* should be discussed. Stakeholders should be able to decide and vote on the best integrated system.

The integrative team process should entail the following steps of design optimization:

- a. The original goals and budget of the project should be revisited to see whether the overall intentions of the project are intact.
- b. The project should be compared with this code or at least one existing green rating system.
- c. Each of the building and *site* components should be scrutinized to help ensure that natural systems for energy conservation, lighting, ventilation, and passive heating and cooling are maximized before mechanical systems are engaged.
- d. The appropriateness and integration logic of the building's primary systems should be confirmed.
- e. The impact of the design on the *site* and its larger context should be evaluated, including the environmental impact on a life-cycle cost basis.
- f. Building information modeling (BIM) software, design tools, and the experience of the design team should be used, where practical, to help optimize the design.
- g. All members of the design team should be included when making design decisions.
- h. Commissioning and consideration of future operation and maintenance (O&M) requirements should be included within the design optimization process.

F101.1.2 (F1.1.2) Design Charrette Matrix. At the end of the charrette process, a matrix for each proposed build-

Scheme #1—with Atrium, maximum exposure on the south, three-story office building.

BUILDING SYSTEM	HIGH-PERFORMANCE CRITERIA						
	SITE	IAQ	IEQ	ENERGY	COMM. M&V	INITIAL COST	O & M
Arch	8	7	6	1	6	1	6
HVAC	—	5	6	2	6	2	7
Plumbing	NA	—	—	—	—	2	7
Structural	—	—	—	—	—	2	
Aggregate index	8	6	6	1.5	6	2	6.8

Result:

Least numbers under energy and cost column defines consumption of substantial energy with high initial cost.

Scheme #2—without Atrium, three-story, minimum exposure on the south and west side.

BUILDING SYSTEM	HIGH-PERFORMANCE CRITERIA						
	SITE	IAQ	IEQ	ENERGY	COMM. M&V	INITIAL COST	O & M
Arch	6	7	7	7	7	7	6
HVAC	NA	5	7	7	7	7	7
Plumbing	NA	—	—	—	7	7	7
Structural	—	—	—	—	—		
Aggregate index	6	6	7	7	7	7	6.8

Result:

High numbers on all columns indicate the building is conceived optimally.

**FIGURE F101.1 (FIGURE F-1)
SAMPLE CHARRETTE DESIGN MATRICES.**

INFORMATIVE APPENDIX G

INFORMATIVE REFERENCES

(This appendix is not part of this code. It is merely informative and does not contain requirements necessary for conformance to the code. It has not been processed according to the ANSI requirements for a code and may contain material that has not been subject to public review or a consensus process. Unresolved objectors on informative material are not offered the right to appeal at ASHRAE or ANSI.)

This appendix contains informative references for the convenience of users of this code and to acknowledge source documents when appropriate. Section numbers indicate where the reference occurs in this document.

AIA

American Institute of Architects
1735 New York Avenue NW
Washington, DC 20006

AIA National/AIA California Council: Integrated Project Delivery: A Guide, v. 1-2007
Appendix F

AISC

American Institute of Steel Construction
130 East Randolph, Suite 2000
Chicago, Illinois 60601

Brochure: Steel Takes LEED® with Recycled Content
901.4.1.1 (9.4.1.1)

ASHRAE

1791 Tullie Circle NE
Atlanta, GA 30329

ASHRAE Guideline 0-2013: The Commissioning Process
1001.3.1.1 (10.3.1.1)

ASHRAE Guideline 1.1-2007 : HVAC&R Technical Requirements for the Commissioning Process
1001.3.1.1 (10.3.1.1)

ASHRAE Guideline 4-2008 (RA 2013): Preparation of Operating and Maintenance Documentation for Building Systems
1001.3.1.1 (10.3.1.1)

ASHRAE Handbook, 2017: Fundamentals
Appendix C

ASHRAE Handbook, 2015: HVAC Applications
Appendix F

ASHRAE Standard 62.1-2016 (Appendix C): Ventilation for Acceptable Indoor Air Quality
Table 1001.3.1.4 (10.3.1.4)

APBP

Association of Pedestrian and Bicycle Professionals
201 East Main Street, Suite 1405
Lexington, KY 40507

Bicycle Parking Guidelines, 2nd Edition, 2010
501.3.7.2 (5.3.7.2)

ASTM

ASTM International
100 Barr Harbor Dr.
West Conshohocken, PA 19428-2959

ASTM C755-10 (2015): Standard Practice for Selection of Water Vapor Retarders for Thermal Insulation, Appendix X1 Problem Analysis

801.3.6 (8.3.6)

ASTM E1331-15: Standard Test Method for Reflectance Factor and Color by Spectrophotometry Using Hemispherical Geometry

801.4.1 (8.4.1)

ASTM E1477 - 98a (2013): Standard Test Method for Luminous Reflectance Factor of Acoustical Materials by Use of Integrating-Sphere Reflectometers

801.4.1 (8.4.1)

ASTM E2813-12e1: Standard Practice for Building Enclosure Commissioning

1001.3.1.3.5 (10.3.1.3.5)

BSI

British Standards Institute
389 Chiswick High Road
London, W4 4AL, United Kingdom

BS 8493:2008+A1:2010: Light reflectance value (LRV) of a surface. Method of test.

801.4.1 (8.4.1)

calEPA

California Environmental Protection Agency
Office of Environmental Health Hazard Assessment
Post Office Box 4010
Sacramento, CA 95812-4010

<http://www.oehha.org/air/allrels.html>: All OEHHA Acute, 8-hour and Chronic Reference Exposure Levels (chRELs) as of June 2014

801.4.2 (8.4.2), 801.5.2 (8.5.2)

CBE

Center for the Built Environment
University of California, 390 Wurster Hall #1839
Berkeley, CA 94720-1839

<http://www.cbe.berkeley.edu/research/survey.htm>: Indoor Environmental Quality (IEQ) Survey™

1001.3.2.1.5 (10.3.2.1.5)

CRI

Carpet and Rug Institute
100 South Hamilton Street
Dalton, Georgia 30720

801.4.2.3 (8.4.2.3)

CSA

Canadian Standards Association
5060 Spectrum Way, Suite 100
Mississauga, Ontario, L4W 5N6, Canada

CSA S478-95 (R2007): Guideline on Durability for Buildings

901.4.1 (9.4.1), 1001.3.2.3 (10.3.2.3)

DGS

State of California, Department of General Services, Procurement Division
Ziggurat Building
707 Third Street
West Sacramento, CA 95605-2811

RFP DGS-56275: Section 5.7, “Indoor Air Quality Requirements for Open Office Panel Systems”

Appendix D

DHHS ATSDR

United States Department of Health and Human Services
Agency for Toxic Substances and Disease Registry
4770 Buford Hwy NE
Atlanta, GA 30341

www.atsdr.cdc.gov/mrls: Minimal Risk Levels (MRLs)

Table 1001.3.1.5 (10.3.1.5)

EPA

United States Environmental Protection Agency
1200 Pennsylvania Ave NW
Washington, DC 20460

Portfolio Manager

1001.3.2.1.3.2 (10.3.2.1.3.2)

FSC

Forest Stewardship Council
1155 30th Street NW, Suite 300
Washington, DC 20007

901.4.1.3.1 (9.4.1.3.1)

GSA

United States General Services Administration
1800 F Street, NW
Washington, DC 20405

U.S. GSA-2005: The Building Commissioning Guide

1001.3.1 (10.3.1)

ICC

International Code Council
500 New Jersey Ave NW # 300
Washington, DC 20001

IBC-2018: International Building Code®

106.1, 801.3.1.8 (8.3.1.8), I201.1 (I2.1)

IECC-2018: International Energy Conservation Code®

Appendix H

IFC-2018: International Fire Code®

601.3.2.6 (6.3.2.6)

IPC-2018: International Plumbing Code®

601.3.1.2.1 (6.3.1.2.1)

ICC/ASHRAE 700-2015: National Green Building Standard

J101.1.1, J101.1.2, J101.1.3, J101.1.4, J101.1.5

IES

Illuminating Engineering Society
120 Wall Street, Floor 17
New York, NY 10005-4001

IDA/IES Model Lighting Ordinance: Model Lighting Ordinance (MLO)

501.3.6 (5.3.6)

ITE

Institute of Transportation Engineers
1627 Eye Street, NW, Suite 600
Washington, DC 20006

4th Edition, 2004: Parking Generation

1001.3.2.4 (10.3.2.4)

MTS

The Institute for Market Transformation to Sustainability
1511 Wisconsin Avenue, N.W.
Washington, D.C. 20007

MTS 1.0 WSIP Guide-2007: Whole Systems Integrated Process Guide for Sustainable Buildings and Communities
Appendix F

NIBS

National Institute of Building Sciences
1090 Vermont Avenue, NW, Suite 700
Washington, DC 20005-4905

NIBS Guideline 3-2012: Building Enclosure Commissioning Process BECx
1001.3.1.3.5 (10.3.1.3.5)

NREL

National Renewable Energy Laboratory
1617 Cole Blvd.
Golden, CO 80401-3393

NREL/TP-550-38617: Source Energy and Emissions Factors for Energy Use in Buildings
Table 701.5.2B (7.5.2B)

RFCI

Resilient Floor Covering Institute
115 Broad Street, Suite 201
LaGrange, GA 30240

801.4.2.3 (8.4.2.3)

SFI

Sustainable Forestry Initiative, Inc.
1600 Wilson Blvd, Suite 810
Arlington, VA 22209

901.4.1.3.1 (9.4.1.3.1)

SMACNA

Sheet Metal and Air Conditioning Contractors National Association
4201 Lafayette Center Drive
Chantilly, VA 20151

ANSI/SMACNA 008-2008: IAQ Guidelines for Occupied Buildings under Construction, Second Edition
1001.3.1.5 (10.3.1.5)

SRI

Steel Recycling Institute
680 Andersen Drive
Pittsburgh, PA 15220

Brochure: Steel Takes LEED® With Recycled Content
901.4.1.1 (9.4.1.1)

UBT

Usable Buildings Trust

Occupant Satisfaction Evaluation Survey: <http://www.busmethodology.org.uk>; info@busmethodology.org.uk
1001.3.2.1.5 (10.3.2.1.5)

UL

UL Environment
2211 Newmarket Parkway, #110
Marietta, GA 30067

UL2818-2013: Greenguard Certification Program for Chemical Emissions for Building Materials, Finishes and Furnishing
801.4.2 (8.4.2), 801.5.2 (8.5.2)

UL2821-2013: Greenguard Certification Program Method for Measuring and Evaluating Chemical Emissions from Building Materials, Finishes and Furnishings
801.4.2 (8.4.2), 801.5.2 (8.5.2)

INFORMATIVE APPENDIX H

OPTION FOR ENERGY EFFICIENCY USING THE IECC PRESCRIPTIVE COMPLIANCE PATH

The provisions contained in this appendix are not mandatory unless specifically referenced in the adopting ordinance. (This appendix is not part of this code. It is merely informative and does not contain requirements necessary for conformance to the code. It has not been processed according to the ANSI requirements for a code and may contain material that has not been subject to public review or a consensus process. Unresolved objectors on informative material are not offered the right to appeal at ASHRAE or ANSI.)

The purpose of this appendix is to provide users of the prescriptive energy path of the IECC a correlated version of ANSI/ASHRAE/ICC/USGBC/IES Standard 189.1, Chapter 7 (Section 7), that facilitates the use of the prescriptive provisions of the IECC without directly relying on the energy provisions of ANSI/ASHRAE/IES Standard 90.1. Section numbers in this appendix, unless otherwise specified, refer to Standard 189.1. Where ASHRAE standards are referenced in this appendix, ASHRAE provides free online access to read-only versions of the standards. See <https://www.ashrae.org/standards-research--technology/standards--guidelines/other-ashrae-standards-referenced-in-code>.

SECTION H101 (H1.)

DEFINITIONS APPLICABLE TO THIS APPENDIX

air, outdoor: see ANSI/ASHRAE Standard 62.1.

building envelope: see ANSI/ASHRAE/IES Standard 90.1.

dynamic glazing: see ANSI/ASHRAE/IES Standard 90.1.

enclosed space: see ANSI/ASHRAE/IES Standard 90.1.

fenestration: see ANSI/ASHRAE/IES Standard 90.1.

vertical fenestration: see ANSI/ASHRAE/IES Standard 90.1.

fenestration area: see ANSI/ASHRAE/IES Standard 90.1.

gross wall area: see ANSI/ASHRAE/IES Standard 90.1.

lighting power allowance: see ANSI/ASHRAE/IES Standard 90.1.

roof: see ANSI/ASHRAE/IES Standard 90.1.

service water heating: see ANSI/ASHRAE/IES Standard 90.1.

single-rafter roof: see ANSI/ASHRAE/IES Standard 90.1.

skylight: see ANSI/ASHRAE/IES Standard 90.1.

space: see ANSI/ASHRAE/IES Standard 90.1.

semiheated space: see ANSI/ASHRAE/IES Standard 90.1.

SECTION H201 (H2.)

GENERAL

H201.1 (H2.1) Scope. This section specifies prescriptive requirements for energy efficiency for buildings and appliances, for *on-site renewable energy systems*, and for energy measuring.

SECTION H301 (H3.) COMPLIANCE

H301.1 (H3.1) Compliance. The energy systems shall comply with Sections 701.3.2 (7.3.2) through 701.3.4 (7.3.4) and with the *International Energy Conservation Code (IECC)*, Sections C402 through C405. In addition, commercial buildings shall comply with the IECC, Section C406, and tenant spaces shall comply with the IECC, Section C406.1.1.

Where requirements are provided below, they shall supersede the requirements of the IECC. For all other criteria, the *building project* shall comply with the requirements of the IECC.

SECTION H401 (H4.) PRESCRIPTIVE REQUIREMENTS

H401.1 (H4.1) On-Site Renewable Energy Systems. *Building projects* shall comply with either the standard renewables approach in Section 701.4.1.1.1 (7.4.1.1.1) or the Alternate Renewables Approach in Section 701.4.1.1.2 (7.4.1.1.2).

H401.2 (H4.2) Building Envelope. The *building envelope* shall comply with the IECC, Sections C301 and C402, with the following modifications and additions.

H401.2.1 (H4.2.1) Continuous Air Barrier. The exceptions to the requirement for a *continuous air barrier* in the IECC, Section C402.5.1, for specific *climate zones* and constructions shall not apply.

H401.2.2 (H4.2.2) Building Envelope Requirements. The *building envelope* shall comply with the requirements in the IECC, Table C402.1.4, with the following modifications to values in the table.

For the opaque elements, each U-factor, C-factor, and F-factor in the table shall be reduced by 5%. For *vertical fenestration* and *skylights*, each U-factor in the IECC, Table C402.4, shall be reduced by 5%. For *skylights* and east-oriented and west-oriented *vertical fenestration*, each *solar heat gain coefficient (SHGC)* in the IECC, Table C402.4, shall be reduced by 5%. These adjustments shall also be applicable where the intent is to comply with the component performance alternative of the IECC, Section C402.1.5.

Exceptions:

1. The U-factor, C-factor, or F-factor shall not be modified where the corresponding R-value

INFORMATIVE APPENDIX I

ADDITIONAL GUIDANCE FOR FUNCTIONAL AND PERFORMANCE TESTING (FPT) AND THE COMMISSIONING (Cx) PROCESS

(This appendix is not part of this code. It is merely informative and does not contain requirements necessary for conformance to the code. It has not been processed according to the ANSI requirements for a code and may contain material that has not been subject to public review or a consensus process. Unresolved objectors on informative material are not offered the right to appeal at ASHRAE or ANSI.)

This appendix provides guidance on best practices for *functional and performance testing (FPT)* and the *commissioning (Cx) process* that relate to Section 1001.3.1.1 (10.3.1.1).

SECTION I101 (I1.) PROVIDER QUALIFICATIONS

I101.1 (I1.1) Recommended Minimum Qualifications and Independence of a Commissioning (Cx) Provider and a Functional and Performance Testing (FPT) Provider. A *commissioning (Cx) provider* or an *FPT provider* should have the following qualities to ensure the needed qualifications and independence for *building project testing* or *commissioning*:

- a. **Equipment.** A *Cx provider* or *FPT provider* should use equipment necessary to carry out the *commissioning (Cx) process* and *FPT*. Equipment should be calibrated in accordance with the manufacturer's specifications.
- b. **Personnel Experience.** The *Cx provider* or *FPT provider* should provide personnel experienced in conducting, supervising, or evaluating *functional and performance testing*, inspections, and, where applicable, performing commissioning activities prior to and subsequent to the tests. Where possible, the *Cx provider* should have completed the *Cx process* on not fewer than two projects of equal or greater scope and complexity, or should be able to demonstrate adequate experience and training in the fundamentals and application of the *Cx process*.
- c. **Independence.** The *Cx provider* and the *FPT provider* should be independent of the building system design and construction functions of the systems being commissioned. The *Cx provider* and *FPT provider* should disclose possible conflicts of interest to ensure objectivity.
- d. **Registration, Licensure, or Certification of a Cx Provider.** Where available, a *Cx provider* should be registered or licensed in a relevant discipline or certified according to the provisions of ISO 17024 or an equivalent certification process.

I101.2 (I1.2) Overview of the Cx Process. Table I101.2 (I1.2) provides an overview of activities, documentation, and responsibilities that should be included in the *Cx process*.

SECTION I201 (I2.) Cx DOCUMENTATION

The *Cx process* should result in the following deliverables.

I201.1 (I2.1) Typical Elements Included in Owner's Project Requirements (OPR). The *OPR* is a document developed by the *owner* with assistance from the design and *Cx* teams that details the requirements of a project and the expectations for how it will be used and operated. The *OPR* should include project goals, measurable performance criteria, cost considerations, benchmarks, success criteria, and supporting information. The term "project intent" or "design intent" is used by some *owners* for their *Cx process OPR*.

The *OPR* document should address the following for the commissioned systems:

- a. Facility objectives, size, location, user requirements, and *owner* directives, including *space* use and occupancy/operations schedules and special project requirements.
- b. Applicable codes and standards, in addition to local building codes (**Informative note:** e.g., *International Building Code*), and environmental, sustainability, and efficiency goals and benchmarks.
- c. Indoor environment requirements, including temperature, humidity, and ventilation.
- d. *Cx process* scope and requirements; listing of equipment; systems and assemblies requiring commissioning, including installation, evaluation, and testing requirements; and *commissioning (Cx) plan* and report formats and distribution requirements. Sampling procedures, if permitted, for all reviews, evaluations, and testing should be detailed.
- e. Equipment, systems, and assemblies requirements, expectations, and warranty provisions.
- f. Maintainability, access, and operational performance requirements.
- g. Project documentation requirements, including formats and delivery schedules for *Basis of Design (BoD)*, *Cx* specifications, *Cx plan* and reports, equipment submittals, and the systems manual; documentation reviews, approvals, and distribution during design and construction phases.

- h. Training requirements for *owner's* operation and maintenance personnel and occupants.

**TABLE I101.2 (TABLE I1.2)
TYPICAL CX PROCESS ACTIVITIES, DELIVERABLES, AND RESPONSIBILITIES**

ITEM	ACTIVITY	DELIVERABLE	NORMALLY PROVIDED BY
1	<i>Owner's project requirements</i>	<i>OPR</i> document	<i>Owner</i> with assistance from design and <i>Cx</i> teams
2	<i>Basis of Design</i>	<i>BoD</i> document	Design team
3	<i>Cx plan</i>	<i>Cx plan</i> document	<i>Cx provider</i> with input from <i>owner</i> , design team, and contractor
4	Contractor <i>Cx</i> requirements	<i>Cx</i> specifications	Design team and <i>Cx provider</i>
5	Design review	<i>Cx</i> design review report	<i>Cx provider</i>
6	Submittal review	Submittal review report	<i>Cx provider</i>
7	Commissioning designated systems inspections, <i>functional and performance testing</i>	Installation, inspection, functional test reports, performance test reports	Contractors, manufacturers, <i>Cx provider</i> and team
8	Issue and resolution log	Issue and resolution logs	<i>Cx provider</i> and team
9	Systems manual	Systems manual	Contractors with review by <i>Cx provider</i>
10	Training	Training plan and reports	Contractor and manufacturers with review by <i>Cx provider</i>
11	Preliminary <i>Cx</i> report	Preliminary <i>Cx</i> report	<i>Cx provider</i>
12	<i>Cx</i> activities during occupancy	Additional information and updates to reports	<i>Cx provider</i> and building operations
13	Final <i>Cx</i> report	Final <i>Cx</i> report	<i>Cx provider</i>

I201.2 (I2.2) Basis of Design (BoD). The *BoD* is a document developed by the design team that records the concepts, calculations, decisions, and product selections used to meet the *OPR* and to satisfy applicable regulatory requirements, standards, and guidelines. The document should include both narrative descriptions and lists of individual items that support the design process, including the following:

- a. A detailed description of the design team's technical approach to, and assumptions about, the *OPR*.
- b. A platform for the review of the design and for changes as the project progresses.
- c. A detailed description addressing coordination of applicable technical and code requirements.

I201.3 (I2.3) Cx Plan. A *Cx plan* is a document developed by a *Cx provider* that should include the following:

- a. An overview of the *Cx process* developed specifically for the project.
- b. The roles and responsibilities of the *Cx provider* and the *Cx* team through final commissioning activities.
- c. Documentation of communication channels and processes, including distribution of the *Cx plan*, logs, testing documents, and reports during the design and construction processes.
- d. A detailed description and schedule of *Cx process* activities and the list of operations, systems, and assemblies that will be commissioned, and a description of performance criteria where not shown on the *construction documents*.

- e. The project design documentation and submittal review procedures and reports.
- f. Inspection checklists and testing forms, issues and resolution log, and *Cx* progress reports to be used during the project to communicate and track commissioning and inspection process information, including format, approvals, and distribution.
- g. The procedures to follow for resolution where the *Cx* evaluation does not meet the *OPR*.

I201.4 (I2.4) Cx Specifications. For construction or renovation projects requiring contract documents, the *owner* should require by agreement that the design/construction team include *Cx* specifications in the project contract documents. The *Cx* specification should require compliance with the *OPR* and with the *Cx process* contained in the project's *Cx plan* as detailed in this code.

I201.5 (I2.5) Cx Design Review Report. The *Cx provider* should provide a design review (*Cx* Design Review Report) to the *owner* and design teams to report compliance with the *OPR* and *BoD*. This *Cx* design review is not intended to replace a design peer review or a code or regulatory review.

I201.6 (I2.6) Record Documents. Record documents should be provided to the *owner* upon project completion. The record documents should be accessible to the building operations and maintenance personnel, be included in the systems manual, and include all of the following:

- a. Approved *construction documents*, including record plans and specifications.

INFORMATIVE APPENDIX J

OPTION FOR RESIDENTIAL COMPLIANCE USING THE NATIONAL GREEN BUILDING STANDARD

The provisions contained in this appendix are mandatory if specifically referenced and specified, wholly or in part, in the enabling law. The National Green Building Standard is a voluntary consensus standard which applies to the design and construction of residential portions of buildings. The Standard establishes criteria for rating the environmental impact of design and construction practices to achieve conformance with specified performance levels for green residential buildings.

SECTION J101 GENERAL

J101.1 Residential requirements determined by the authority having jurisdiction. The authority having jurisdiction shall determine if one or more of the following sections apply.

J101.1.1. Detached one- and two-family dwellings and multiple single-family dwellings (townhouses) not more than three stories in height above grade plane with a separate means of egress, their accessory structures, and the site or lot upon which these buildings are located shall comply with ICC/ASHRAE 700–2015 *National Green Building Standard*.

J101.1.2. Group R-3 residential buildings, their accessory structures, and the site or lot upon which these buildings are located shall comply with ICC/ASHRAE 700–2015 *National Green Building Standard*.

J101.1.3. Group R-2 and R-4 residential buildings three stories or less in height above grade plane, their accessory structures, and the site or lot upon which these buildings are located shall comply with ICC/ASHRAE 700–2015 *National Green Building Standard*.

J101.1.4. Group R-2 and R-4 residential buildings four stories or more in height above grade plane, their accessory structures, and the site or lot upon which these buildings are located shall comply with the provisions of this code or ICC/ASHRAE 700–2015 *National Green Building Standard*.

J101.1.5. Group R-2 and R-4 portions of mixed use buildings shall comply with the provisions of this code or ICC/ASHRAE 700–2015 *National Green Building Standard*. The remainder of the building and the site upon which the building is located shall comply with the provisions of this code.

INFORMATIVE APPENDIX K

ADDENDA DESCRIPTION INFORMATION

(This appendix is not part of this code. It is merely informative and does not contain requirements necessary for conformance to the code. It has not been processed according to the ANSI requirements for a code and may contain material that has not been subject to public review or a consensus process. Unresolved objectors on informative material are not offered the right to appeal at ASHRAE or ANSI.)

ANSI/ASHRAE/ICC/USGBC/IES Standard 189.1-2017 incorporates ANSI/ASHRAE/USGBC/IES Standard 189.1-2014 and Addenda a, b, c, d, e, f, g, i, j, k, l, m, n, o, p, q, r, s, t, u, v, w, x, y, z, aa, ab, ac, ad, ae, ag, ah, ai, aj, ak, al, am, ap, aq, as, au, av, aw, ax, ay, az, ba, bb, bd, be, bh, bi, bj, bk, bl, bn, bo, bp, bq, br, bs, bt, bu, bv, bw, bx, by, bz, cd, ce, cf, cg, ch, cj, and cl to ANSI/ASHRAE/USGBC/IES Standard 189.1-2014. Table K101.1 (J-1) lists each addendum and describes the way in which the code is affected by the change. It also lists the ASHRAE, and ANSI approval dates for each addendum.

TABLE K101.1 (TABLE J-1)
ADDENDA TO ANSI/ASHRAE/USGBC/IES STANDARD 189.1-2014

ADDENDUM	SECTIONS AFFECTED	DESCRIPTION OF CHANGES*	ASHRAE STANDARDS COMMITTEE APPROVAL	COSPONSOR APPROVAL (USGBC, IES, ICC)	ASHRAE BOD APPROVAL	ANSI APPROVAL
a	Section 701.4.3.2 (7.4.3.2)	This addendum clarifies the location of a CO ₂ sensor to determine the outdoor air concentration.	Jan. 23, 2016	Jan. 11, 2016 Dec. 31, 2015 Dec. 22, 2015	Jan. 27, 2016	Jan. 28, 2016
b	Section 701.3.4 (7.3.4)	This addendum replaces the mandatory requirement for peak load reduction in Section 701.3.4 (7.3.4) that was introduced in addendum ce to the code.	June 27, 2015	May 12, 2015 June 29, 2015 N/A	July 1, 2015	July 2, 2015
c	Section 1001.3.1.2 (10.3.1.2) and Chapter 11 (Section 11)	This addendum is intended to incorporate ANSI/ASHRAE/IES Standard 202, Commissioning Process for Buildings and Systems, into Standard 189.1, thereby basing commissioning on an industry standard.	Oct. 13, 2015	Sept. 30, 2015 Sept. 28, 2015 Oct. 8, 2015	Oct. 19, 2015	Nov. 2, 2015
d	Section 701.4.6.1.1 (7.4.6.1.1)	This addendum corrects and clarifies a potentially confusing sentence in the standard that could cause some designers to believe that the bonus lighting power control factors from ASHRAE Standard 90.1, Table 9.6.3, cannot be used in Standard 189.1.	Jan. 23, 2016	Jan. 11, 2016 Dec. 31, 2015 Dec. 22, 2015	Jan. 27, 2016	Jan. 28, 2016
e	Sections 301.2 (3.2), 701.4.6.1.1 (7.4.6.1.1), 1001.3.1.1.3 (10.3.1.1.3), and 1001.3.1.2.4 (10.3.1.2.4)	This new Section 701.4.6.1.1(d) [7.4.6.1.1(d)] to Standard 189.1 provides control credits for institutional tuning that are in addition to the control factors that already exist in Standard 90.1-2013, Section 9.6.3.	Jan. 23, 2016	Jan. 11, 2016 Dec. 31, 2015 Dec. 22, 2015	Jan. 27, 2016	Jan. 28, 2016
f	Table 601.3.2.1 (6.3.2.1)	This addendum modifies Table 601.3.2.1 (6.3.2.1) to make it consistent with the text of Section 601.3.2.1(b) [6.3.2.1(b)].	June 25, 2016	July 4, 2016 June 27, 2016 June 9, 2016	June 29, 2016	June 30, 2016
g	Sections 801.3.1.4 (8.3.1.4) and 1001.3.2.1.4.7 (10.3.2.1.4.7)	This addendum to Standard 189.1 provides a higher level of indoor moisture control than is currently required by reference to Standard 62.1.	Jan. 23, 2016	Jan. 11, 2016 Dec. 31, 2015 Dec. 22, 2015	Jan. 27, 2016	Jan. 28, 2016
i	Sections 501.3.5.3 (5.3.5.3), 501.3.5.5 (5.3.5.5), 1001.3.2.1.1 (10.3.2.1.1), and Chapter 11 (Section 11)	This addendum reorganizes the roof heat island mitigation section and adds new provisions for vegetated terrace and roofing systems.	Jan. 28, 2017	Feb. 11, 2017 Jan. 31, 2017 Jan. 12, 2017	Feb. 1, 2017	Feb. 13, 2017
j	Sections 501.3.1.2 (5.3.1.2)	This addendum clarifies the exceptions contained under Section 501.3.1.2 (5.3.1.2), "Prohibited Development Activity," which includes provisions for fish/wildlife habitat conservation areas and wetlands.	Aug. 24, 2016	July 4, 2016 June 27, 2016 June 9, 2016	Aug. 29, 2016	Aug. 30, 2016

* These descriptions may not be complete and are provided for information only.

(continued)

TABLE K101.1 (TABLE J-1)
ADDENDA TO ANSI/ASHRAE/USGBC/IES STANDARD 189.1-2014 (Continued)

ADDENDUM	SECTIONS AFFECTED	DESCRIPTION OF CHANGES*	ASHRAE STANDARDS COMMITTEE APPROVAL	COSPONSOR APPROVAL (USGBC, IES, ICC)	ASHRAE BOD APPROVAL	ANSI APPROVAL
k	Section 701.4.2.1 (7.4.2.1)	This addendum is based in part on a comparison of 189.1 with the 2015 <i>International Green Construction Code</i> (IgCC). The change from 10% to 5% in the U-, C- and F- factors and in the SHGC is based on it being more practical to design and build, while having only a limited impact on energy use.	Feb. 1, 2017	Feb. 11, 2017 Jan. 31, 2017 Jan. 12, 2017	Feb. 1, 2017	March 2, 2017
l	Chapter 9 (Section 9) and Section 901.1 (9.1)	This addendum revises the title and scope of Chapter 9 (Section 9) in order to improve clarity and more accurately describe the content of the section.	Feb. 1, 2017	Feb. 11, 2017 Jan. 31, 2017 Jan. 12, 2017	Feb. 1, 2017	March 2, 2017
m	Section 501.3.7.1.1 (5.3.7.1.1)	This addendum augments provisions for connection of on-site walkways and bicycle paths to street sidewalks and bicycle paths.	Aug. 24, 2016	July 4, 2016 June 27, 2016 June 9, 2016	Aug. 29, 2016	Aug. 30, 2016
n	Section 901.3.5 (9.3.5)	This addendum clarifies footnote b to Table 7.5.2A of Standard 189.1-2014. This footnote provides a method to adjust the percent reduction for buildings with unregulated energy cost exceeding 35% of the total energy cost.	Jan. 28, 2017	Feb. 11, 2017 Jan. 31, 2017 Jan. 12, 2017	Feb. 1, 2017	Feb. 13, 2017
o	Chapters 1 and 2 (Sections 1 and 2)	This addendum revises the existing purpose and scope of the standard to clarify the intended purposes of the standard and its application and to better reflect revisions to the standard that are being considered by the committee.	April 6, 2017	April 13, 2017 March 28, 2017 March 31, 2017	April 17, 2017	May 20, 2017
p	Chapter 3 (Section 3) and Section 601.3.2.1 (6.3.2.1)	This addendum adds requirements for water-bottle filling stations, which are intended to improve water efficiency and sanitation of public drinking water and reduce the environmental effects of plastic bottles.	Jan. 28, 2017	Feb. 11, 2017 Jan. 31, 2017 Jan. 12, 2017	Feb. 1, 2017	Feb. 13, 2017
q	Sections 401.1.4 (4.1.4), 501.3.5.3 (5.3.5.3), 701.4.2.1 (7.4.2.1), 701.4.2.5 (7.4.2.5), 701.4.3.7.2 (7.4.3.7.2), and Chapter 11 (Section 11); Tables 701.4.3.3 (7.4.3.3) and 801.4.1.2 (8.4.1.2); Appendix A	This addendum Standard 189.1 was developed in response to the update of ASHRAE Standard 169-2013, Climatic Data for Building Design Standards. Standard 189.1 now references ANSI/ASHRAE/IES Standard 90.1 and Standard 169 for climatic data and includes criteria for Climate Zone 0.	Aug. 24, 2016	July 4, 2016 June 27, 2016 June 9, 2016	Aug. 29, 2016	Aug. 30, 2016
r	Section 701.4.3.3 (7.4.3.3)	This addendum lowers the threshold for duct leakage testing to include 2 in. pressure class ducts, which are common upstream of VAV boxes.	June 28, 2017	June 14, 2017 June 13, 2017 June 12, 2017	June 28, 2017	Aug. 1, 2017
s	Chapter 6 (Section 6)	This addendum removes the performance option for water use and moves the prescriptive option into the mandatory section.	April 6, 2017	April 13, 2017 March 28, 2017 March 31, 2017	April 17, 2017	May 20, 2017
t	Sections 601.3.4 (6.3.4) and 601.3.5 (6.3.5)	This addendum adds new requirements for reverse osmosis and on-site reclaim water systems in order to reduce the likelihood of excessive water use due to poor design of water treatment and filter systems.	Jan. 28, 2017	Feb. 11, 2017 Jan. 31, 2017 Jan. 12, 2017	Feb. 1, 2017	Feb. 13, 2017

* These descriptions may not be complete and are provided for information only.

(continued)

TABLE K101.1 (TABLE J-1)
ADDENDA TO ANSI/ASHRAE/USGBC/IES STANDARD 189.1-2014 (Continued)

ADDENDUM	SECTIONS AFFECTED	DESCRIPTION OF CHANGES*	ASHRAE STANDARDS COMMITTEE APPROVAL	COSPONSOR APPROVAL (USGBC, IES, ICC)	ASHRAE BOD APPROVAL	ANSI APPROVAL
u	Section 601.3.4 (6.3.4)	This addendum adds new requirements for water softeners to reduce water consumption, given the impact of their design and efficiency on water discharge water rates.	Jan. 28, 2017	Feb. 11, 2017 Jan. 31, 2017 Jan. 12, 2017	Feb. 1, 2017	Feb. 13, 2017
v	Sections 301.2 (3.2), 501.3.1.1 (5.3.1.1), and Chapter 11 (Section 11)	This addendum revises two paragraphs in Section 501.3.1.1 (5.3.1.1), "Allowable Sites." The revisions reference ASTM standards that provide more precision than the requirements that currently exist in Standard 189.1.	April 6, 2017	April 13, 2017 March 28, 2017 March 31, 2017	April 17, 2013	May 1, 2017
w	Section 701.5.2 (7.5.2)	This addendum updates Performance Option A of Section 701.5.2 (7.5.2) to be consistent with recent changes to the Performance Rating Method as published in Standard 90.1-2016.	April 6, 2017	April 13, 2017 March 28, 2017 March 31, 2017	April 17, 2013	May 1, 2017
x	Section 701.5 (7.5); Appendix C	This addendum deletes Performance Path B and sections of Appendix C, motivated in part by changes to the Performance Rating Method published in Standard 90.1-2016, which made significant structural changes to the performance compliance path on which the requirements in Standard 189.1 are heavily based.	Jan. 28, 2017	Feb. 11, 2017 Jan. 31, 2017 Jan. 12, 2017	Feb. 1, 2017	Feb. 13, 2017
y	Sections 1001.3.2.1 (10.3.2.1), 1001.3.2.1.4 (10.3.2.1.4) and 1001.3.2.1.5 (10.3.2.1.5); Appendix G	This addendum adds a requirement for an Indoor Environmental Quality (IEQ) occupant satisfaction survey to be included in the postoccupancy plan for operation.	Jan. 28, 2017	Feb. 11, 2017 Jan. 31, 2017 Jan. 12, 2017	Feb. 1, 2017	Feb. 13, 2017
z	Tables 701.4.6.1A (7.4.6.1A) and 701.4.6.1B (7.4.6.1B)	This addendum revises the lighting power density (LPD) requirements in Standard 189.1 to include parking structures.	Jan. 28, 2017	Feb. 11, 2017 Jan. 31, 2017 Jan. 12, 2017	Feb. 1, 2017	Feb. 13, 2017
aa	Sections 301.2 (3.2), 701.4.1.1 (7.4.1.1), and Chapter 11 (Section 11)	This addendum revises current requirements for renewable energy systems and related exceptions. It requires that renewable energy certificates (RECs) be retained and retired by the building owner for all compliance options.	July 24, 2017	July 24, 2017 July 26, 2017 July 24, 2017	Aug. 1, 2017	Aug. 23, 2017
ab	Section 701.4.3.7 (7.4.3.7)	This addendum adds SI values to the requirements for kitchen hood exhausts. The SI values were extracted from Standard 90.1-2016, Table 6.5.7.2.2, which has the same table content as Table 701.4.3.7 (7.4.3.7).	Jan. 28, 2017	Feb. 11, 2017 Jan. 31, 2017 Jan. 12, 2017	Feb. 1, 2017	Feb. 13, 2017
ac	Section 701.3.4 (7.3.4)	This addendum deletes the existing Section 701.3.4 (7.3.4) and replaces with new text that is based in part on concepts that are included in the 2015 <i>International Green Construction Code</i> .	June 23, 2017	June 14, 2017 June 13, 2017 June 12, 2017	June 28, 2017	June 29, 2017
ad	Section 701.4.2.5 (7.4.2.5) and 801.4.1.3 (8.4.1.3)	This addendum changes the requirements for permanent projections (such as balconies, overhangs, or shading devices). It deletes the prescriptive requirements for permanent projections in Climate Zones 4A and 5, retaining the requirements in Climate Zones 0 through 3, 4B, and 4C.	June 23, 2017	June 14, 2017 June 13, 2017 June 12, 2017	June 28, 2017	June 29, 2017

* These descriptions may not be complete and are provided for information only.

(continued)

TABLE K101.1 (TABLE J-1)
ADDENDA TO ANSI/ASHRAE/USGBC/IES STANDARD 189.1-2014 (Continued)

ADDENDUM	SECTIONS AFFECTED	DESCRIPTION OF CHANGES*	ASHRAE STANDARDS COMMITTEE APPROVAL	COSPONSOR APPROVAL (USGBC, IES, ICC)	ASHRAE BOD APPROVAL	ANSI APPROVAL
ae	Section 501.3.8 (5.3.8)	This addendum adds a new Section 501.3.8 (5.3.8), which addresses plans for the treatment of waste materials originating from the development of a building project site.	June 23, 2017	June 14, 2017 June 13, 2017 June 12, 2017	June 28, 2017	June 29, 2017
ag	Section 701.4.2 (7.4.2)	This addendum makes creates a new definition for plants that are suitable for inclusion in this code. It replaces “adapted plants” in Chapter 6 (Section 6) to better define the desired vegetation and to avoid conflicting with the term’s use in Chapter 5 (Section 5).	June 23, 2017	June 14, 2017 June 13, 2017 June 12, 2017	June 28, 2017	June 29, 2017
ah	Table 701.5.3 (7.5.3)	This addendum revises the lighting power density (LPD) requirements in Standard 189.1 for exterior parking areas using the same methodology employed in Standard 90.1 but targeting a high level of performance.	April 6, 2017	April 13, 2017 March 28, 2017 March 31, 2017	April 17, 2013	May 1, 2017
ai	Sections 701.4.2.4 (7.4.2.4), 1001.3.1.2.4 (10.3.1.2.4), and Chapter 11 (Section 11)	This addendum adds requirements for testing, installing, and commissioning air curtains in building entrances. These requirements are intended to ensure that air curtains function and operate as intended.	June 28, 2017	June 14, 2017 June 13, 2017 June 12, 2017	June 28, 2017	Aug. 1, 2017
aj	Sections 701.4.6.4 (7.4.6.4) and 701.4.6.5 (7.4.6.5)	This addendum revises the bilevel motion control requirements to better align with the requirements of Standard 90.1-2016, which increased the lighting power reduction from 30% to 50% for signs and most exterior lighting (except façade and landscape lighting) after business hours.	April 6, 2017	April 13, 2017 March 28, 2017 March 31, 2017	April 17, 2013	May 1, 2017
ak	Sections 901.5 (9.5) and Chapter 11 (Section 11)	This addendum revises Section 901.5 (9.5) to reflect advancements in the implementation of life-cycle assessment and to reference ASTM E2921, Standard Practice for Minimum Criteria for Comparing Whole Building Life Cycle Assessments for Use with Building Codes and Rating Systems.	July 24, 2017	July 24, 2017 July 26, 2017 July 24, 2017	Aug 1, 2017	Aug. 23, 2017
al	Section 501.3.7.3 (5.3.7.3)	This addendum modifies the provisions for electric-vehicle charging infrastructure to include an additional option to provide electric conduit from electric service panels to parking lot spaces during new-building construction	July 24, 2017	July 24, 2017 July 26, 2017 July 24, 2017	July 26, 2017	July 27, 2017
am	Section 501.3.5.3 (5.3.5.3)	This addendum modifies the roof heat island mitigation section that was previously changed via addendum i. The only change is to adjust the steep-slope roof SRI from 15 to 25, which matches the 2015 IgCC and is slightly less than the LEED V4 SRI of 32.	June 23, 2017	June 14, 2017 June 13, 2017 June 12, 2017	June 28, 2017	June 29, 2017
ap	Chapter 11 (Section 11) and Appendix G	This addendum to Standard 189.1-2014 updates the normative references in Chapter 11 (Section 11) and the informative references in Appendix G.	April 6, 2017	April 13, 2017 March 28, 2017 March 31, 2017	April 17, 2013	May 1, 2017
aq	Chapters 3 and 10 (Sections 3 and 10)	This addendum updates requirements in Standard 189.1 for functional and performance testing and for building systems commissioning. These changes are intended to harmonize the standard with requirements and methods included in the 2015 <i>International Green Construction Code</i> and to update the standard with respect to trends and terminology in the evolving commissioning industry.	July 24, 2017	July 24, 2017 July 26, 2017 July 24, 2017	Aug 1, 2017	Aug. 23, 2017

* These descriptions may not be complete and are provided for information only.

(continued)

TABLE K101.1 (TABLE J-1)
ADDENDA TO ANSI/ASHRAE/USGBC/IES STANDARD 189.1-2014 (Continued)

ADDENDUM	SECTIONS AFFECTED	DESCRIPTION OF CHANGES*	ASHRAE STANDARDS COMMITTEE APPROVAL	COSPONSOR APPROVAL (USGBC, IES, ICC)	ASHRAE BOD APPROVAL	ANSI APPROVAL
as	Sections 301.2 (3.2), 301.3 (3.3), 801.3.3 (8.3.3), Chapters 10 and 11 (Sections 10 and 11)	This addendum updates the acoustical requirements of Standard 189.1. Its development included comparison with the <i>International Green Construction Code</i> , Acoustical Society of America, Facilities Guideline Institute, and LEED, and benefited from the participation of ASHRAE TC 2.6, Sound and Vibration Control.	July 24, 2017 July 26, 2017 July 24, 2017	Aug 1, 2017	Sept. 12, 2017	
au	Sections 301.2 (3.2), Chapters 6 and 11 (Sections 6 and 11)	This addendum provides additional requirements for irrigation systems to improve water use efficiency, based in part on consideration of requirements included in the IgCC.	June 14, 2017 June 13, 2017 June 12, 2017	June 28, 2017	June 29, 2017	
av	Section 701.4.6.1.1 (7.4.6.1.1); Tables 701.4.6.1A (7.4.6.1A) and 701.4.6.1B (7.4.6.1B)	This addendum simplifies the application of lighting power allowances in ASHRAE/USGBC/IES Standard 189.1 and increases their stringency, while maintaining the same provisions for illuminance.	June 14, 2017 June 13, 2017 June 12, 2017	June 28, 2017	June 29, 2017	
aw	Sections 301.2 (3.2), 801.3.8 (8.3.8) and 801.3.9 (8.3.9); Table 801.4.1.2A (8.4.1.2A)	This addendum adds two new mandatory requirements to Chapter 8 (Section 8), "Indoor Environmental Quality," with regard to occupant control of operable methods of glare control and of automatic daylight-responsive controls.	July 24, 2017 July 26, 2017 July 24, 2017	Aug 1, 2017	Aug. 23, 2017	
ax	Section 601.4.3 (6.4.3)	This addendum modifies the existing requirements on water features by focusing on those circumstances, malfunctioning automatic water refilling values, which are most likely to use excessive water.	April 13, 2017 March 28, 2017 March 31, 2017	April 17, 2013	May 1, 2017	
ay	Sections 601.4.4 (6.4.4)	This addendum adds requirements for dual plumbing in new buildings so that non-potable waters (when available) can be used to flush toilets and urinals.	July 24, 2017 July 26, 2017 July 24, 2017	Aug 1, 2017	Aug. 23, 2017	
az	Section 501.3.3.2 (5.3.3.2)	This addendum adds exceptions to the calculation of the area of greenfields that must consist of biodiverse plantings other than turfgrass.	July 24, 2017	Aug 1, 2017	Aug. 23, 2017	
ba	Sections 801.3 (8.3) and Chapter 11 (Section 11)	This addendum updates the broad reference in Section 801.3.1 (8.3.1) to a wide range of requirements in both Standard 62.1 and Standard 170 to more narrowly cite the specific sections of those standards that are relevant to Standard 189.1.	April 13, 2017 March 28, 2017 March 31, 2017	April 17, 2013	May 1, 2017	
bb	Section 701.3.3.2 (7.3.3.2)	This addendum adds a new requirement to Chapter 7 (Section 7) to display energy use in support of existing requirements in Section 1001.3.2.1.3.2 (10.3.2.1.3.2), "Track and Assess Energy Consumption."	June 14, 2017 June 13, 2017 June 12, 2017	June 28, 2017	June 29, 2017	
bd	Table 701.5.2B (7.5.2B)	This addendum updates carbon dioxide equivalent values in Table 701.5.2B (7.5.2B).	July 24, 2017	July 26, 2017	July 27, 2017	
be	Sections 801.3.1 (8.3.1) and Chapter 11 (Section 11)	This addendum requires that the products of combustion from any equipment or system that is permanently installed indoors be vented to the outside.	June 14, 2017 June 13, 2017 June 12, 2017	June 28, 2017	Aug. 3, 2017	

* These descriptions may not be complete and are provided for information only.

(continued)

TABLE K101.1 (TABLE J-1)
ADDENDA TO ANSI/ASHRAE/USGBC/IES STANDARD 189.1-2014 (Continued)

ADDENDUM	SECTIONS AFFECTED	DESCRIPTION OF CHANGES*	ASHRAE STANDARDS COMMITTEE APPROVAL	COSPONSOR APPROVAL (USGBC, IES, ICC)	ASHRAE BOD APPROVAL	ANSI APPROVAL
bh	Appendix B; Table B101.1 (B-1)	This addendum revises the requirements in ASHRAE/USGBC/ IES Standard 189.1, Table B-1, Electrical-Operated Unitary Air Conditioners and Condensing Units, to adjust the efficiency metrics for industry improvements for these products.	June 23, 2017	June 14, 2017 June 13, 2017 June 12, 2017	June 28, 2017	June 29, 2017
bi	Chapter 3 (Section 3); Appendix B; Table B101.5 (B-5)	This addendum modifies Table B101.5 (B-5), which defines the requirements for single packaged vertical air conditioners, single packaged vertical heat pumps, room air conditioners, and room air-conditioner heat pumps.	June 23, 2017	June 14, 2017 June 13, 2017 June 12, 2017	June 28, 2017	June 29, 2017
bj	Appendix B; Table B101.6 (B-6)	This addendum updates requirements in ASHRAE/USGBC/IES Standard 189.1, Table B-6, "Warm Air Furnace and Combination Warm Air Furnaces/Air-Conditioning Units, Warm Air Duct Furnaces, and Unit Heaters."	June 23, 2017	June 14, 2017 June 13, 2017 June 12, 2017	June 28, 2017	June 29, 2017
bk	Appendix B; Tables B101.12 (B-12) and B101.13 (B-13)	This addendum modifies Tables B101.12 (B-12), Electrically Operated Variable-Refrigerant-Flow (VRF) Air Conditioners Minimum Efficiency, and Table B101.13 (B-13), Electrically Operated Variable-Refrigerant-Flow (VRF) Heat-Pump Air Conditioners Minimum Efficiency.	June 23, 2017	June 14, 2017 June 13, 2017 June 12, 2017	June 28, 2017	June 29, 2017
bl	Appendix B; Table B101.9 (B-9)	This addendum updates the efficiency requirements in Table B101.9 (B-9) to reflect changes in efficiency metrics.	June 23, 2017	June 14, 2017 June 13, 2017 June 12, 2017	June 28, 2017	June 29, 2017
bn	Section 801.3 (8.3)	This addendum updates the soil-gas control requirements in Chapter 8 (Section 8) to increase the protection of building occupants against radon exposure, specifying the key elements of effective soil-gas control.	July 24, 2017	July 24, 2017 July 26, 2017 July 24, 2017	July 26, 2017	July 27, 2017
bo	Chapters 3 and 11 (Sections 3 and 11)	This addendum broadens and simplifies the existing definition of "side-lighting effective aperture" in ASHRAE/USGBC/IES Standard 189.1 in order to clarify its application in the prescriptive daylighting requirements in Section 801.4.1.2 (8.4.1.2).	June 23, 2017	June 14, 2017 June 13, 2017 June 12, 2017	June 28, 2017	June 29, 2017
bp	Sections 801.4.2.1 (8.4.2.1) and Chapter 11 (Section 11)	This addendum updates existing requirements for the emissions or VOC content in adhesives and sealants by updating references, adding accreditation requirements for testing laboratories and clarifying language related to the VOC content requirements.	June 23, 2017	June 14, 2017 June 13, 2017 June 12, 2017	June 28, 2017	June 29, 2017
bq	Sections 801.4.4.2 (8.4.4.2) and Chapter 11 (Section 11)	This addendum updates the existing requirements for the emissions or VOC content for paints and coating materials by adding accreditation requirements for testing laboratories, clarifying the language related to the VOC contents requirements, and updating references.	June 23, 2017	June 14, 2017 June 13, 2017 June 12, 2017	June 28, 2017	June 29, 2017
br	Sections 801.4.2.3 (8.4.2.3) and Chapter 11 (Section 11)	This addendum updates the existing requirements for the emissions for floor covering materials by adding accreditation requirements for testing laboratories, updating product categories to be consistent with CDPH/EHLB v1.1, adding a list of materials that are deemed to comply, and updating references.	June 23, 2017	June 14, 2017 June 13, 2017 June 12, 2017	June 28, 2017	June 29, 2017

* These descriptions may not be complete and are provided for information only.

(continued)

TABLE K101.1 (TABLE J-1)
ADDENDA TO ANSI/ASHRAE/USGBC/IES STANDARD 189.1-2014 (Continued)

ADDENDUM	SECTIONS AFFECTED	DESCRIPTION OF CHANGES*	ASHRAE STANDARDS COMMITTEE APPROVAL	COSPONSOR APPROVAL (USGBC, IES, ICC)	ASHRAE BOD APPROVAL	ANSI APPROVAL
bs	Sections 801.4.2.6 (8.4.2.6) and Chapter 11 (Section 11)	This addendum updates the existing requirements for the emissions for ceiling and wall assemblies by modifying the list of materials covered, adding a separate subsection on insulation, adding a list of materials that are deemed to comply, adding accreditation requirements for testing laboratories, and updating references.	June 23, 2017	June 14, 2017 June 13, 2017 June 12, 2017	June 28, 2017	June 29, 2017
bt	Sections 701.3.1.1 (7.3.1.1), 1001.3.1.2.5 (10.3.1.2.5), and Chapter 11 (Section 11)	This addendum updates requirements for building envelope airtightness testing in ASHRAE/USGBC/IES Standard 189.1 based on changes in ANSI/ASHRAE/IES Standard 90.1-2016.	June 23, 2017	June 14, 2017 June 13, 2017 June 12, 2017	June 28, 2017	June 29, 2017
bu	Appendix B; Table B101.2 (B-2)	This addendum revises the efficiency requirements in ASHRAE/USGBC/IES Standard 189.1, Table B-2, Electrically Operated Unitary and Applied Heat Pumps Minimum Efficiency Requirements (1-P), to adjust the efficiency metrics for industry improvements for these products.	June 23, 2017	June 14, 2017 June 13, 2017 June 12, 2017	June 28, 2017	June 29, 2017
bv	Appendix B; Table B101.3 (B-3)	This addendum updates the centrifugal chiller requirement for $K_{s,dip}$, which currently exists as a footnote to Table B101.3 (B-3), to reflect changes to AHRI Standards 550/590 and 551/591. The revised requirement is in alignment with ANSI/ASHRAE/IES Standard 90.1.	June 28, 2017	June 14, 2017 June 13, 2017 June 12, 2017	June 28, 2017	June 29, 2017
bw	Appendix B; Table B101.4 (B-4)	This addendum updates the requirements in Table B101.4 (B-4) for electrically operated packaged-terminal air conditioners and packaged-terminal heat pumps.	July 24, 2017	July 24, 2017 July 26, 2017 July 24, 2017	July 26, 2017	July 27, 2017
bx	Appendix B; Table B101.8 (B-8)	This addendum makes changes to Table B101.8 (B-8), "Performance Requirements for Heat-Rejection Equipment," to update some of the efficiency requirements to align with changes in the industry.	July 24, 2017	July 24, 2017 July 26, 2017 July 24, 2017	July 26, 2017	July 27, 2017
by	Section 801.3.1.4 (8.3.1.4)	This addendum provides a higher level of indoor moisture control (primarily to reduce the likelihood of microbial growth on interior surfaces and within the building envelope) than is currently required by Standard 189.1's reference to Standard 62.1.	June 27, 2015	May 12, 2015 June 29, 2015 N/A	July 1, 2015	July 2, 2015
bz	Appendix B; Tables B101.3 (B-3), B101.10 (B-10), B101.14 (B-14) and B101.15 (B-15)	This addendum updates tables for Water-Chilling Packages, Commercial Refrigerator and Freezers, Commercial Refrigeration Minimum Efficiency Requirements and low-Voltage Dry-Type Distribution Transformers in Appendix B.	June 23, 2017	June 14, 2017 June 13, 2017 June 12, 2017	June 28, 2017	June 29, 2017
cd	Sections 301.2 (3.2), 801.4.1 (8.4.1), 801.5.1 (8.5.1) and Chapter 11 (Section 11)	This addendum revises the daylight requirements in Section 801.4 (8.4), "Prescriptive Compliance Path," and Section 801.5 (8.5), "Performance Option."	June 23, 2017	June 14, 2017 June 13, 2017 June 12, 2017	June 28, 2017	June 29, 2017

* These descriptions may not be complete and are provided for information only.

(continued)

TABLE K101.1 (TABLE J-1)
ADDENDA TO ANSI/ASHRAE/USGBC/IES STANDARD 189.1-2014 (Continued)

ADDENDUM	SECTIONS AFFECTED	DESCRIPTION OF CHANGES*	ASHRAE STANDARDS COMMITTEE APPROVAL	COSPONSOR APPROVAL (USGBC, IES, ICC)	ASHRAE BOD APPROVAL	ANSI APPROVAL
ce	Chapter 7 (Section 7)	This addendum revises modifications to the mandatory and prescriptive requirements for peak load reduction in Chapter 7 (Section 7). The existing prescriptive requirement in Section 701.4.5.1 (7.4.5.1) is deleted, and a mandatory requirement is added in Section 701.3.4 (7.3.4).	June 27, 2015	May 12, 2015 June 29, 2015 N/A	July 1, 2015	July 2, 2015
cf	Appendix E	This addendum updates Informative Appendix E to make it consistent with changes approved by addendum k, which changed the building envelope requirements in Section 701.4.2.1 (7.4.2.1). It also adds tables for Climate Zone 0, consistent with addendum q.	May 22, 2017	May 15, 2017 May 12, 2017 May 11, 2017	N/A	N/A
cg	Appendix I	This addendum adds a new informative appendix to aid in understanding and adoption of the functional and performance testing (FPT) and commissioning (Cx) processes of Chapter 10 (Section 10).	May 22, 2017	May 15, 2017 May 12, 2017 May 11, 2017	N/A	N/A
ch	Chapters 5 and 11 (Sections 5 and 11)	This addendum to ASHRAE Standard 189.1 contains updates to references.	July 24, 2017	July 24, 2017 July 26, 2017 July 24, 2017	July 26, 2017	July 27, 2017
cj	Appendix H	This addendum adds an informative appendix for use in correlating the prescriptive energy path provisions of this standard with those of the <i>International Energy Conservation Code</i> (IECC).	May 22, 2017	May 15, 2017 May 12, 2017 May 11, 2017	N/A	N/A
cl	Table 701.5.2A (7.5.2A)	This addendum updates Table 701.5.2A (7.5.2A) to provide consistency with changes to ASHRAE Standard 90.1-2016, which is referenced by Standard 189.1, and to changes in the stringency of the prescriptive requirements in Standard 189.1, Chapter 7 (Section 7).	July 24, 2017	July 24, 2017 July 26, 2017 July 24, 2017	July 26, 2017	July 27, 2017

* These descriptions may not be complete and are provided for information only.

NOTE

Approved addenda, errata, or interpretations for this standard can be downloaded free of charge from the ASHRAE website at <http://www.ashrae.org/technology>.

ANNEX 1

REFERENCED STANDARD REPRODUCTION ANNEX ASHRAE STANDARD 169

(This annex contains normative material from an existing ASHRAE standard that is cited in this code. This annex is not part of this code; its inclusion is merely informative. It is included here to facilitate use of this code.)

Annex 1 contains extractions of material from ASHRAE Standard 169. The table below lists where in Standard 189.1 this material is referenced and whether it is referenced normatively or informatively.

STANDARD 189.1 SECTION	ANNEX 1 FIGURE/TABLE/SECTION	ASHRAE STANDARD 169 MATERIAL	STATUS IN STANDARD 189.1
Appendix A	Figure Annex1-1	Figure B-1, Climate Zones for United States Counties	Informative
Appendix A	Section Annex1-1	Section A3 Climate Zone Definitions	Normative
Appendix A	Table Annex1-1	Table A-3 Thermal Climate Zone Definitions	Normative

Informative Note: Section references that appear in this annex are references to sections or appendices in ANSI/ASHRAE Standard 169.

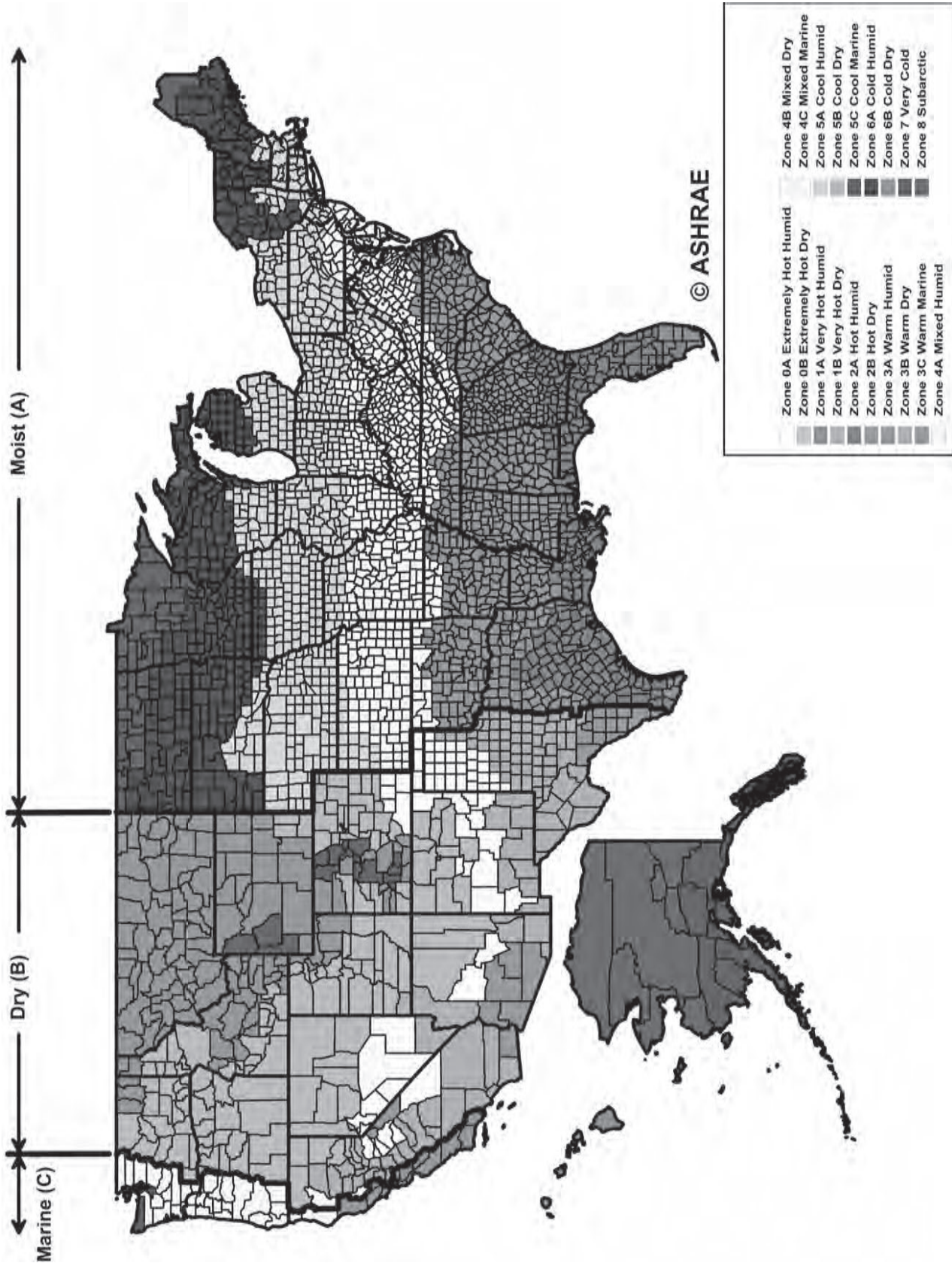

FIGURE ANNEX 101.1 (FIGURE ANNEX 1-1)
ASHRAE STANDARD 169-2013, FIGURE B-1: CLIMATE ZONES FOR UNITED STATES COUNTIES.

**SECTION ANNEX 101 (SECTION ANNEX 1-1)
ASHRAE STANDARD 169-2013, SECTION A3:
CLIMATE ZONE DEFINITIONS**

**SECTION A301 (A3.)
CLIMATE ZONE DEFINITIONS**

To determine the climate zones for locations not listed in this code, use the following information to determine climate zone numbers and letters.

Determine the thermal climate zone, 0–8, from Table Annex 101.1 (1-1), using the heating and cooling degree-days for the location.

Determine the moisture zone (Marine, Dry or Humid):

- a. If monthly average temperature and precipitation data are available, use the Marine, Dry, and Humid definitions below to determine the moisture zone (C, B, or A).
- b. If annual average temperature information (including degree-days) and annual precipitation (i.e. annual mean) are available, use the following to determine the moisture zone:
 1. If thermal climate zone is 3 and $CDD_{50^{\circ}F} \leq 4500$ ($CDD_{10^{\circ}C} \leq 2500$), climate zone is Marine (3C).
 2. If thermal climate zone is 4 and $CDD_{50^{\circ}F} \leq 2700$ ($CDD_{10^{\circ}C} \leq 1500$), climate zone is Marine (4C).
 3. If thermal climate zone is 5 and $CDD_{50^{\circ}F} \leq 1800$ ($CDD_{10^{\circ}C} \leq 1000$), climate zone is Marine (5C).

Use the third criteria below for determining the Dry/Humid threshold if not Marine (C).

- c. If only degree-day information is available, use the following to determine the moisture zone:
 1. If thermal climate zone is 3 and $CDD_{50^{\circ}F} \leq 4500$ ($CDD_{10^{\circ}C} \leq 2500$), climate zone is Marine (3C).
 2. If thermal climate zone is 4 and $CDD_{50^{\circ}F} \leq 2700$ ($CDD_{10^{\circ}C} \leq 1500$), climate zone is Marine (4C).
 3. If thermal climate zone is 5 and $CDD_{50^{\circ}F} \leq 1800$ ($CDD_{10^{\circ}C} \leq 1000$), climate zone is Marine (5C).

It is not possible to assign Dry/Humid splits in this case.

Marine (C) Zone Definition—Locations meeting all four of the following criteria:

- a. Mean temperature of coldest month between 27°F (−3°C) and 65°F (18°C);

- b. Warmest month mean < 72°F (22°C);
- c. At least four months with mean temperatures over 50°F (10°C); and
- d. Dry season in summer. The month with the heaviest precipitation in the cold season has at least three times as much precipitation as the month with the least precipitation in the rest of the year. The cold season is October through March in the Northern Hemisphere and April through September in the Southern Hemisphere.

Dry (B) Definition—Locations meeting the following criteria:

- a. Not Marine (C);
- b. If 70% or more of the precipitation, P , occurs during the high sun period, then the dry/humid threshold is:

$$P < 0.44 \times (T - 7) \quad (\text{I-P})$$

$$P < 20.0 \times (T + 14) \quad (\text{SI})$$

- c. If between 30% and 70% of the precipitation, P , occurs during the high sun period, then the dry/humid threshold is:

$$P < 0.44 \times (T - 19.5) \quad (\text{I-P})$$

$$P < 20.0 \times (T + 7) \quad (\text{SI})$$

- d. If 30% or less of the precipitation, P , occurs during the high sun period, then the dry/humid threshold is:

$$P < 0.44 \times (T - 32) \quad (\text{I-P})$$

$$P < 20 \times T \quad (\text{SI})$$

where:

P = annual precipitation, in. (mm).

T = annual mean temperature, °F (°C).

Summer or high sun period = April through September in the Northern Hemisphere and October through March in the Southern Hemisphere.

Winter or cold season = October through March in the Northern Hemisphere and April through September in the Southern Hemisphere.

Humid (A) Definition—Locations that are not Marine (C) and not Dry (B).

TABLE ANNEX 101.1 (TABLE ANNEX1-1)
ASHRAE STANDARD 169-2013, TABLE A-3: THERMAL CLIMATE ZONE DEFINITIONS

THERMAL ZONE	NAME	I-P UNITS	SI UNITS
0	Extremely hot	$10,800 < \text{CDD}50^{\circ}\text{F}$	$6000 < \text{CDD}10^{\circ}\text{C}$
1	Very hot	$9000 < \text{CDD}50^{\circ}\text{F} \leq 10,800$	$5000 < \text{CDD}10^{\circ}\text{C} \leq 6000$
2	Hot	$6300 < \text{CDD}50^{\circ}\text{F} \leq 9000$	$3500 < \text{CDD}10^{\circ}\text{C} \leq 5000$
3	Warm	$\text{CDD}50^{\circ}\text{F} \leq 6300$ and $\text{HDD}65^{\circ}\text{F} \leq 3600$	$\text{CDD}10^{\circ}\text{C} < 3500$ and $\text{HDD}18^{\circ}\text{C} \leq 2000$
4	Mixed	$\text{CDD}50^{\circ}\text{F} \leq 6300$ and $3600 < \text{HDD}65^{\circ}\text{F} \leq 5400$	$\text{CDD}10^{\circ}\text{C} < 3500$ and $2000 < \text{HDD}18^{\circ}\text{C} \leq 3000$
5	Cool	$\text{CDD}50^{\circ}\text{F} \leq 6300$ and $5400 < \text{HDD}65^{\circ}\text{F} \leq 7200$	$\text{CDD}10^{\circ}\text{C} \leq 3500$ and $3000 < \text{HDD}18^{\circ}\text{C} \leq 4000$
6	Cold	$7200 < \text{HDD}65^{\circ}\text{F} \leq 9000$	$4000 < \text{HDD}18^{\circ}\text{C} \leq 5000$
7	Very cold	$9000 < \text{HDD}65^{\circ}\text{F} \leq 12600$	$5000 < \text{HDD}18^{\circ}\text{C} \leq 7000$
8	Subarctic/arctic	$12600 < \text{HDD}65^{\circ}\text{F}$	$7000 < \text{HDD}18^{\circ}\text{C}$

Specify and Approve with

CONFIDENCE



When facing new or unfamiliar materials, how do you know if they comply with building codes and standards?

- ICC-ES® Evaluation Reports are the most widely accepted and trusted technical reports for code compliance. When you specify products or materials with an ICC-ES report, you avoid delays on projects and improve your bottom line.
- ICC-ES® Reports save time and resources, and permit quick and easy access to compliance information relevant to a product to determine its code or standard compliance and installation requirements.
- ICC-ES® provides a one-stop shop for the evaluation, listing and now testing of innovative building products through our newly formed cooperation with Innovation Research Labs, a highly respected ISO 17025 accredited testing lab with over 50 years of experience.
- ICC-ES® is a subsidiary of ICC®, the publisher of the codes used throughout the U.S. and many global markets, so you can be confident in their code expertise.



WWW.ICC-ES.ORG | 800-423-6587 x3877



18-15551



SOLAR RATING
& CERTIFICATION
CORPORATION

A member of the ICC
Family of Companies

Solar Rating & Certification Corporation (ICC-SRCC)

ICC-SRCC, a program of the ICC Evaluation Service, is an accredited certification body with programs for the certification and performance rating of solar heating and cooling products and small wind turbines. ICC-SRCC certifications and ratings are specified by many jurisdictions and programs that promote the use of solar heating and cooling technologies.

ICC-SRCC's certifications and listings assist code enforcement professionals, allowing them to quickly confirm the code compliance of solar heating and cooling products and small wind turbines. Consumers benefit from objective, third-party performance data that allows them to compare products and find the best options for their project.

ICC-SRCC CERTIFIES:

- Solar thermal collectors
- Domestic solar water heating systems
- Solar air heating systems
- Solar pump stations
- Solar pool heating systems
- Small wind turbines

ICC-SRCC BENEFITS INCLUDE:

- Evaluations of compliance to ICC-SRCC Standards 100, 300 and 400 that are referenced in many codes throughout North America
- Objective performance ratings and energy savings estimates for solar water heaters
- Proof of compliance with many federal, state and local rebate programs
- Web-based directory of certifications and ratings

Need more information?

Contact the Solar Rating & Certification Corporation today!

www.solar-rating.org | 1-888-422-7233, x7735

Connect with us on Twitter and LinkedIn

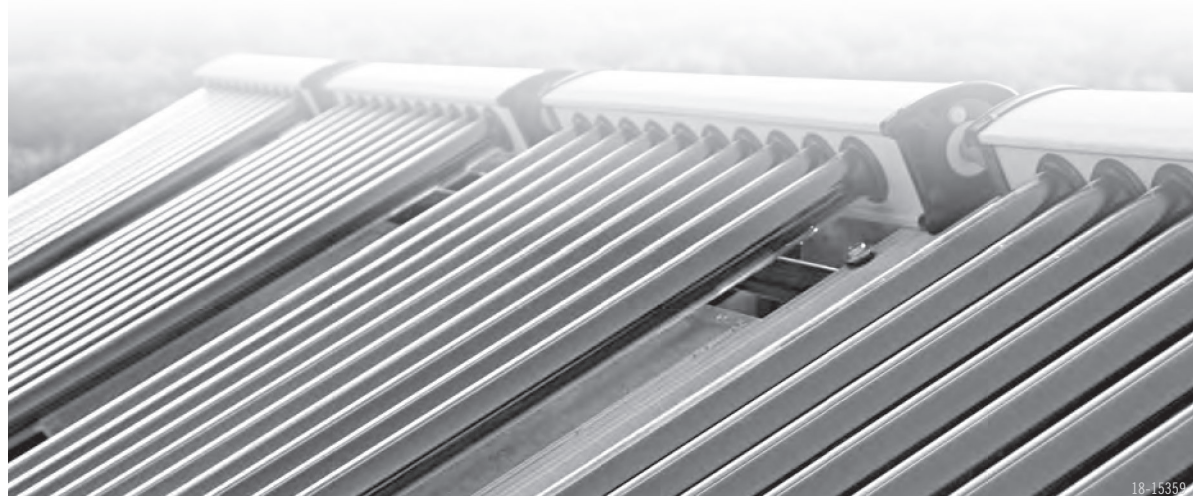



Overwhelmed with a backlog of Plan Reviews?

The I-Code experts at ICC's Plan Review Services *can help you reduce your plan review backlog, even in the busiest construction season.* With more than 200 years of combined experience with applications of the codes, no plan review is too complex or too large for our experienced team of I-Code professionals.

With expertise in ALL the International Codes® (I-Codes®), we can perform complete plans reviews or a specific aspect of a plan.

Either way, you'll receive the most detailed and precise plan reviews in the industry!

Codes Reviewed

- ICC International Codes
- State and local amendments based on the I-Codes (except Performance Code)

Disciplines Reviewed

- Building (structural & nonstructural)
- Fire Protection Systems (includes sprinklers)
- Electrical
- Energy Conservation
- Mechanical
- Accessibility
- Plumbing

To learn how ICC's I-Code experts can help you reduce your plan review backlog, call 888-422-7233, x5577. Or visit www.iccsafe.org/PLR5



LEARNING center



Training and Education

The Learning Center at ICC provides training and education to building safety, fire, design, and construction professionals on how best to apply and enforce the codes and leadership topics.

Training and education programs are designed for maximum impact and results by assisting you in developing professional skills, advancing your career, expanding your knowledge base, and/or preparing for your next certification exam. Stay on the leading edge of the industry while earning valuable CEUs.

All Learning Center training opportunities are developed and led by nationally recognized code experts with decades of experience. We offer convenient learning opportunities in a variety of formats including classroom, virtual, live web session and online courses.



CLASSROOM

The Learning Center's multi-day Institute, single-day Seminars, and Certification Test Academies offer in-depth training from leading code and building safety experts held at locations throughout the U.S. Network with your peers and get on-the-job questions answered at an in person training. Also, Hire ICC to Teach provides the opportunity to bring ICC's expert instructors to the location of your choice. Choose from a wide range of topics or work with the Learning Center experts to develop customized training to meet your needs.



VIRTUAL CLASSROOM

Join a live training event from any location – whether you're in the office or at home. All you need is a standard internet connection. Virtual classrooms are a hybrid learning environment where you participate remotely and experience the same collaboration, instructor interaction and learning benefits as if you were physically in the classroom.



LIVE WEB SESSION

Participate in targeted training events by taking advantage of a web session series to give you the training you need in the timeframe you need it while getting all the CEUs you need for certification renewal.



ONLINE

Online learning is available 24/7 and features topics such as exam study, code training, management, leadership, and financial planning.



PREFERRED PROVIDER PROGRAM

Open the door to extensive training opportunities with ICC-approved educational offerings by a variety of providers as they relate to codes, standards and guidelines, as well as building construction materials, products and methods.

For information about the Learning Center: visit learn.iccsafe.org or call **888-422-7233, x33821**